

= Parts not used
 Nicht benötigte Bauteile
 Pièces non utilisées
 Not benötigte inwards
 Piezas no utilizadas

1

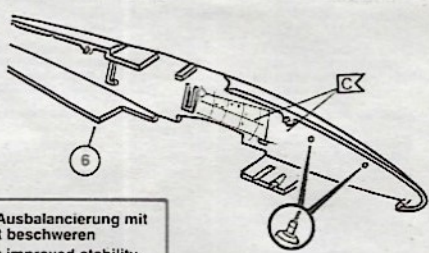
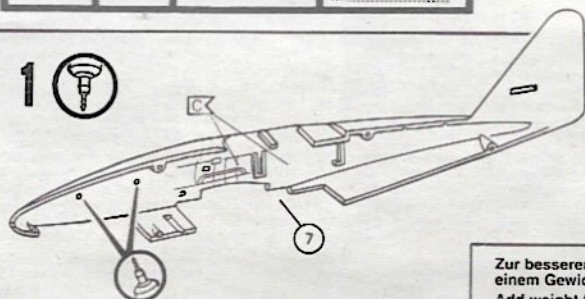

Zur besseren Ausbalancierung mit
 einem Gewicht beschweren
 Add weight for improved stability

2

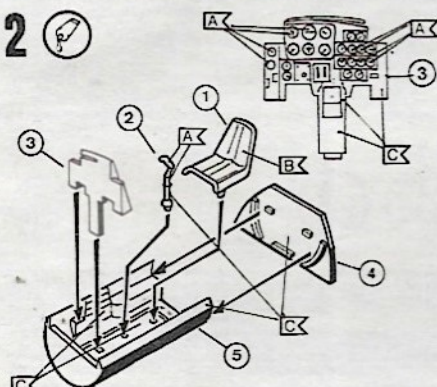

3

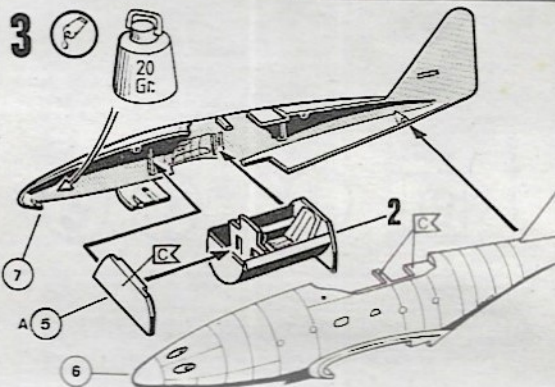

4

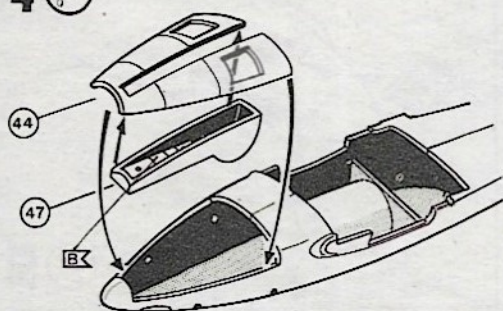

5

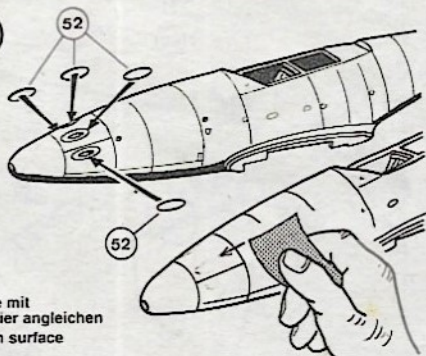

Oberfläche mit
Schleifpapier angleichen
Sand down surface

6

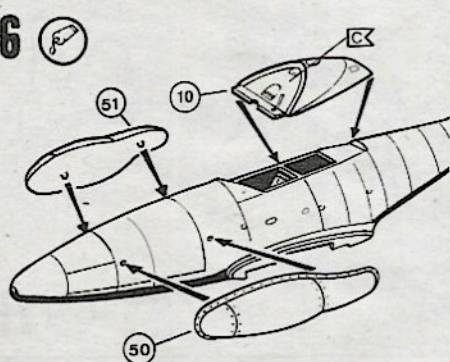

7

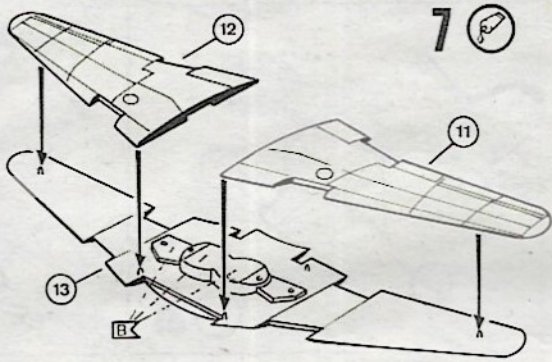

8

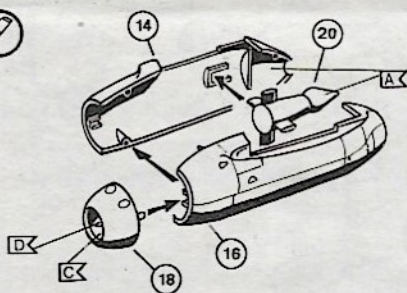

9

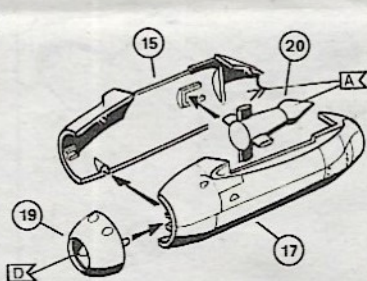



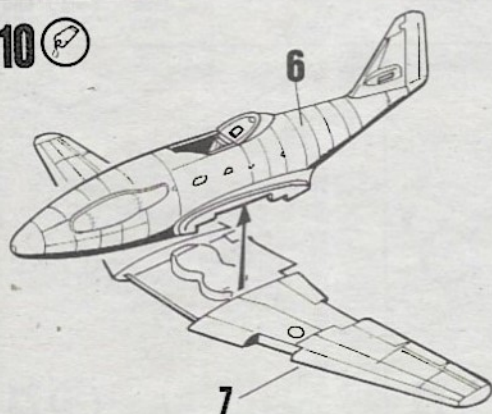



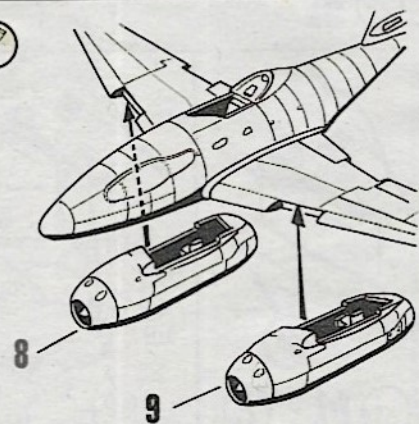

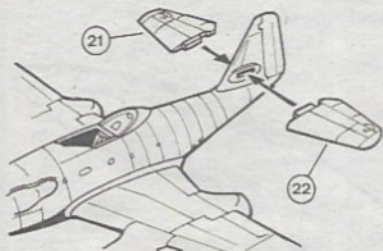

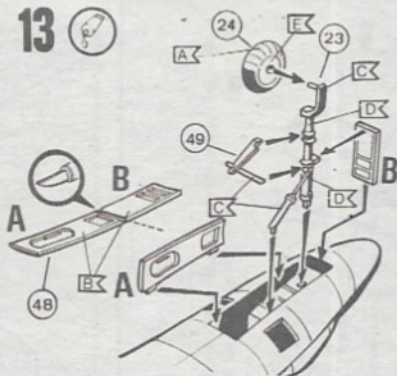

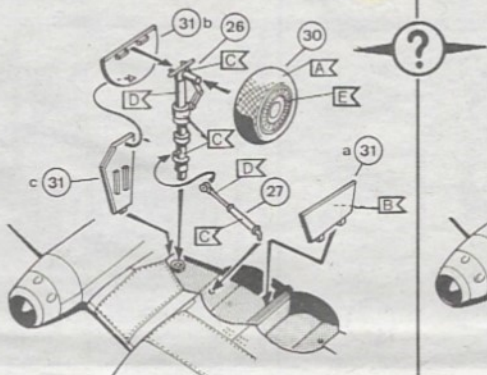
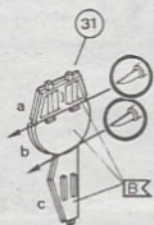
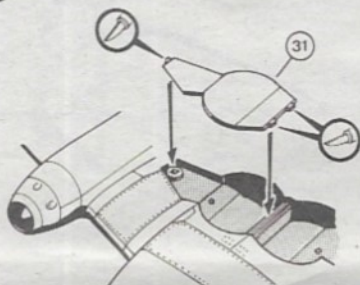

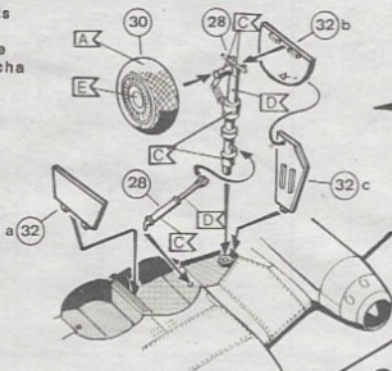
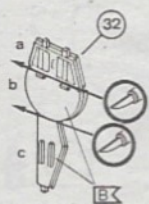
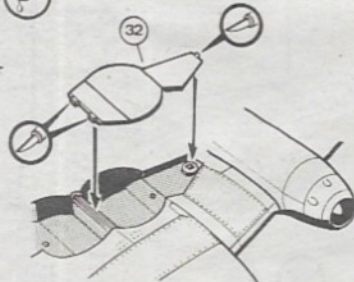
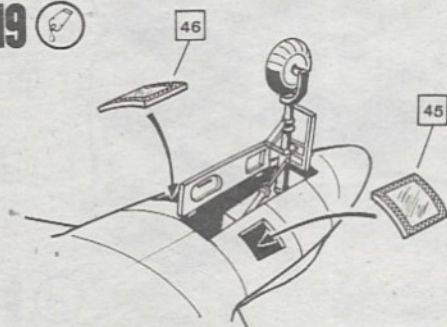
10

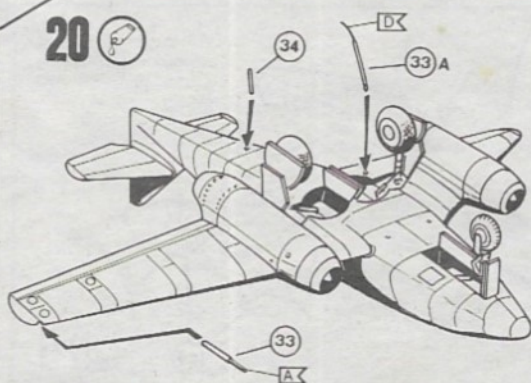

11

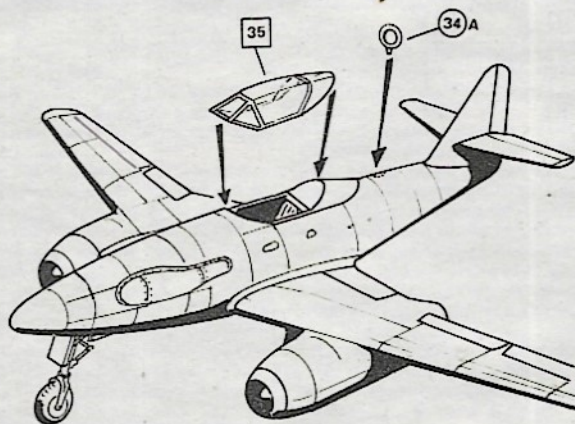

12 13 ? 14 15 links
left
gauche
izquierda? 16 17 rechts
right
droite
derecha? 18 19 20 

21 22  

Messerschmitt Me 262 A-1a/U3
der Nahaufklärungsgruppe 6 (NAGr. 6), Burg/b. Magdeburg, März 1945

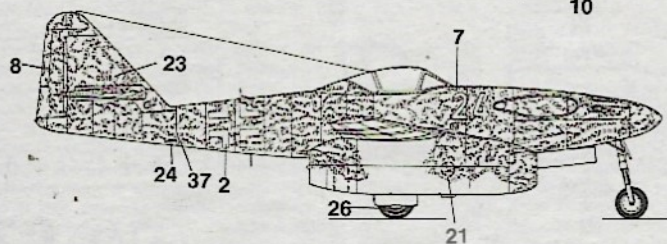
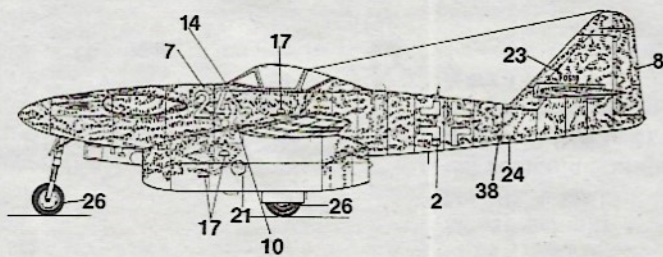
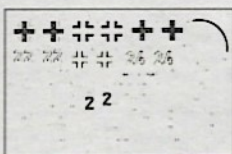

23

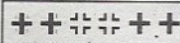

2 2

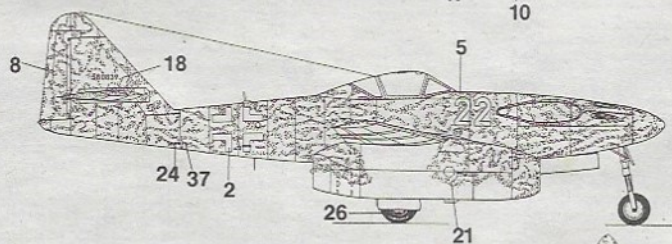
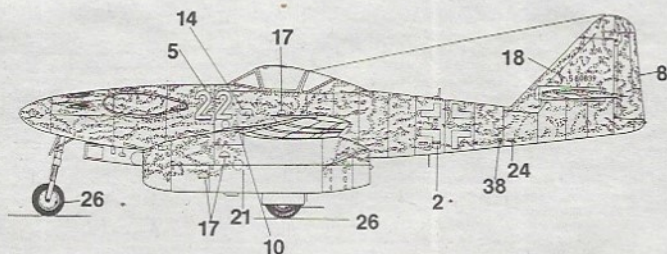

Messerschmitt
Me 262 A-1a/U3
der Nahaufklärungs-
gruppe 6 (NAGr. 6),
Burg/b. Magdeburg,
März 1945

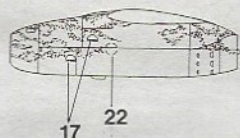

R inside

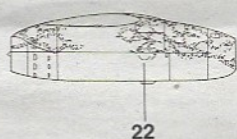

L inside

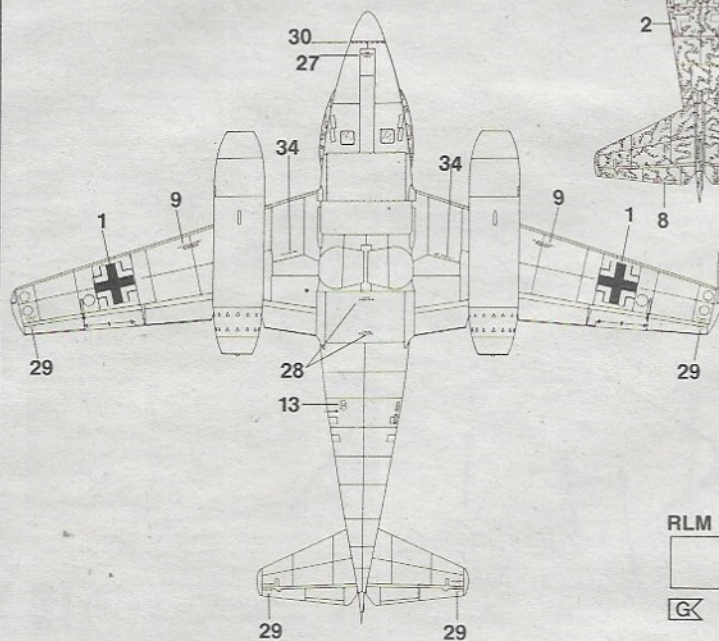
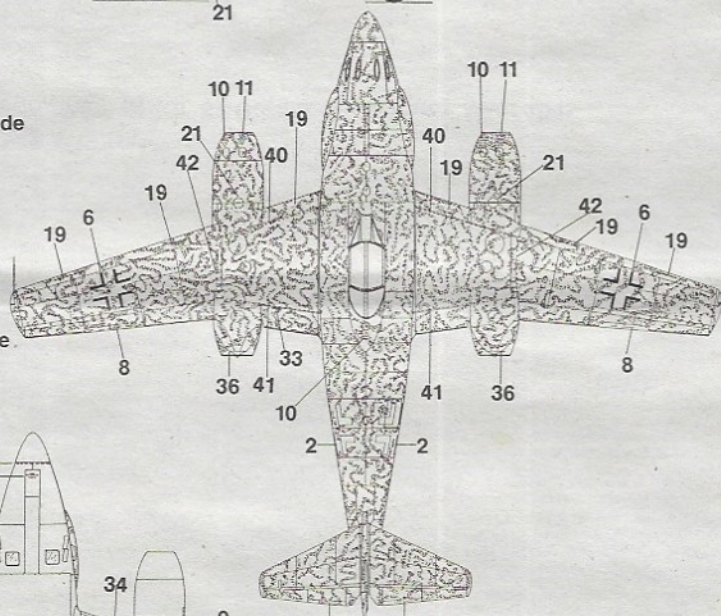

RLM 76



G

RLM 82



H

24



+++++

22 22 26 26

2 2

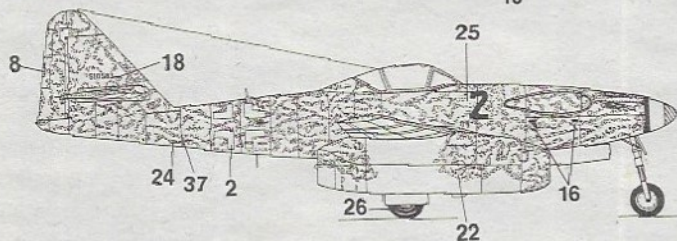
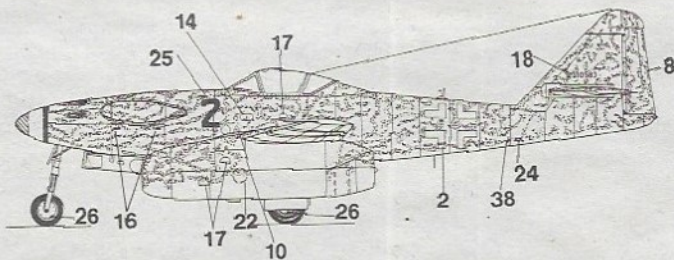

Messerschmitt
Me 262 A-1a/U3
der Nahaufklärungs-
gruppe 1 (NAGr. 1),
Fritzlar, März 1945

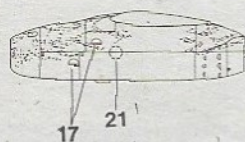

R inside

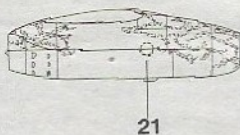

L inside

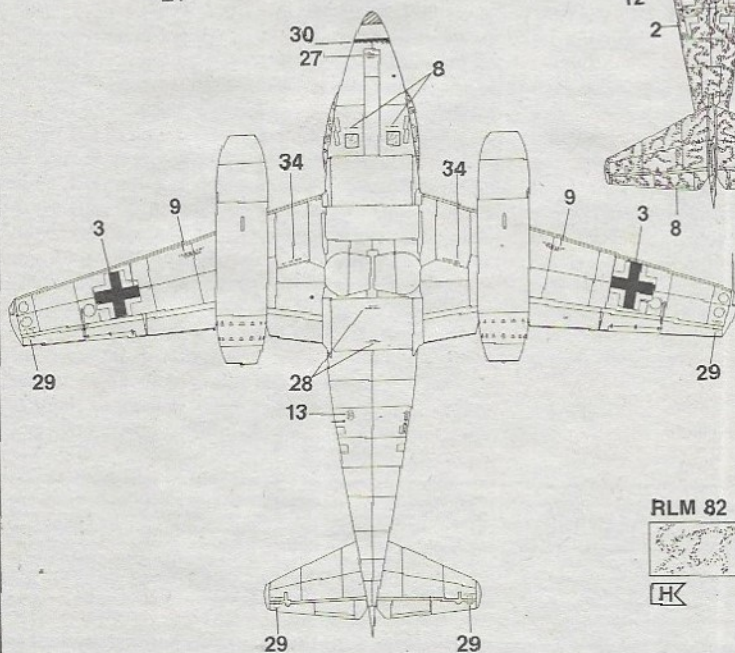
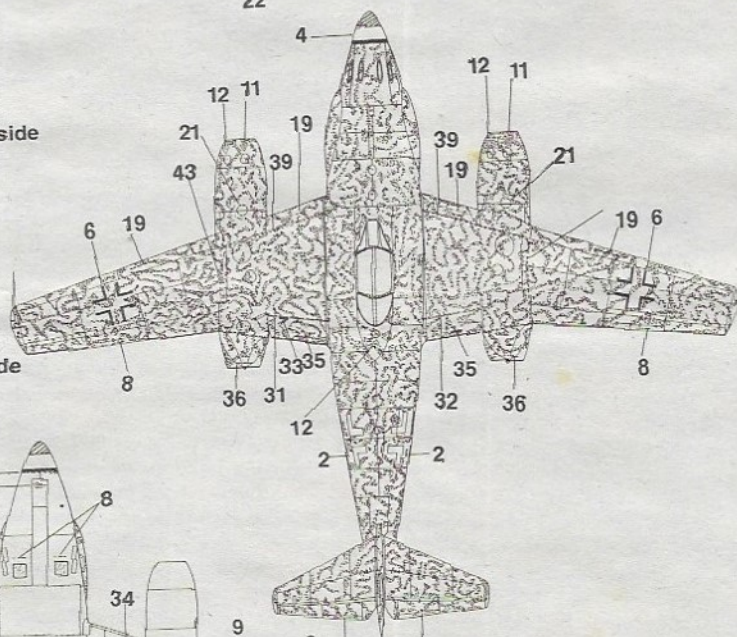

RLM 82



H

RLM 23



F

RLM 76



G

Revell 

Me 262 A-1a/U3 Aufklärer/
Recce

1:72

Plastik-Modellbausatz
Plastic model kit
Modèle réduit
Modelbouwdoos

↔ 14,6 cm

⟨○⟩ 17,3 cm

Flugzeug-Illustration,
Aircraft-illustration,
Illustration d'un avion,
Vliegtuig-illustratie:
J. Velc

04146

