

CANADIAN T17E1 STAGHOUND MK. I EQUIPPED 60LB ROCKET LAUNCH (LATE PRODUCTION)

1/35 SCALE

加拿大獵犬裝甲車連飛彈發射架60LB (後期生產型)

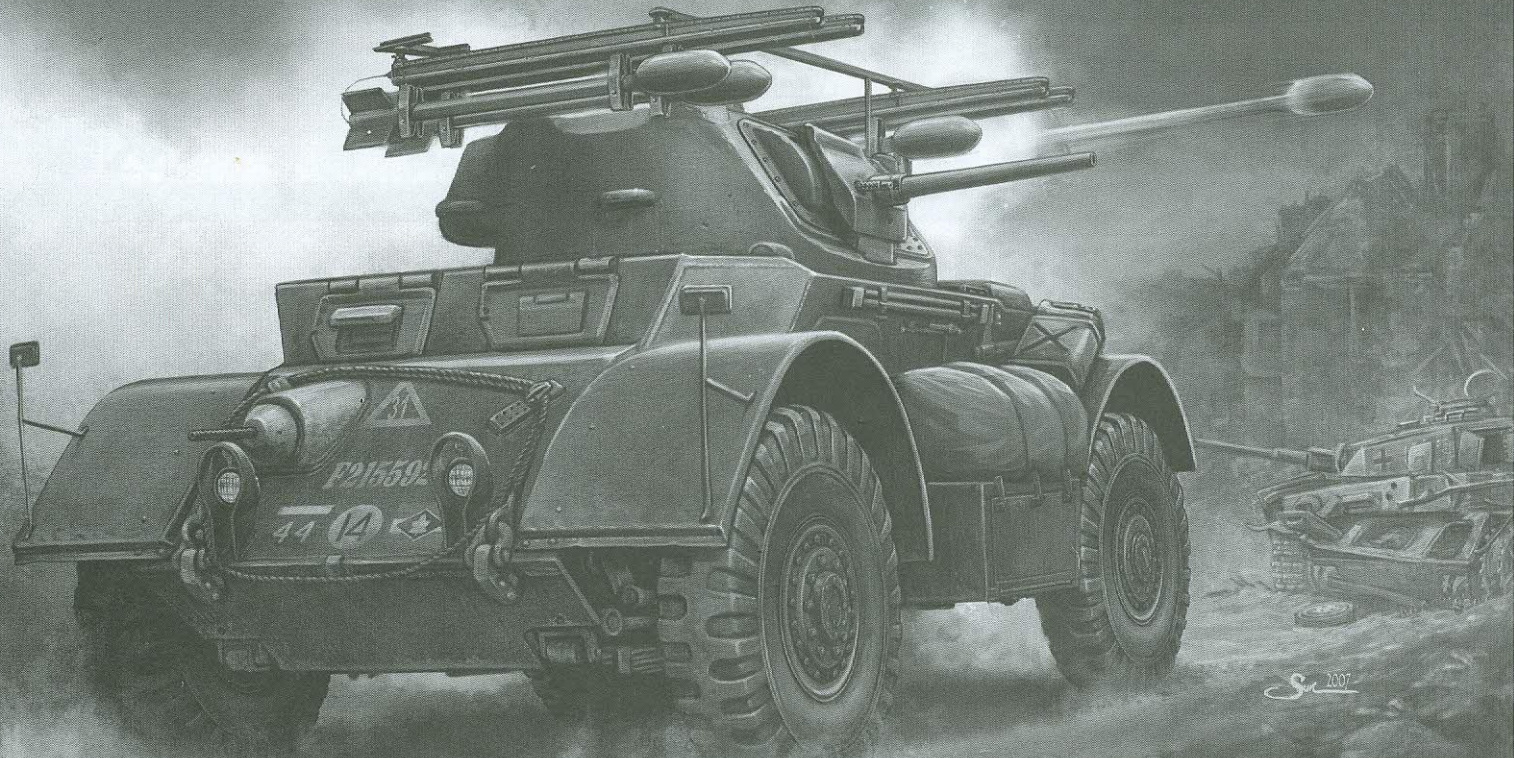

In July 1941 plans were drawn up for a large 4x4 armoured car, by the Chevrolet Motor Company, This car was designated the T17E1 and was ordered by both the US Army and the British Army in January 1942, the British naming the vehicle the Staghound. The Staghound emerged as a 14 ton armoured car powered by 2 x GMC 6-Cylinder, 97 bhp petrol engines, with a top speed of 89 km/h. Armour was up to 32mm thick, and the car was armed with a 37mm M6 anti-tank gun. The Car was ready for production in October 1942, but shortly after this, the US Army canceled its order. The entire production would go to the British Army where they were primarily used as Command and Control cars in Armoured Car Regiments. However some Armoured Car Regiments, such as the 18th Canadian ACR, (12th Manitoba Dragoons), used the Staghound as its primary equipment. Some cars of the 12th Manitoba Dragoons were fitted with launch rails to fire aircraft rockets.

The 12th Manitoba Dragoons was the Armoured car Regiment attached to Canadian 2nd Corps fighting in N.W. Europe. The rocket launchers were probably fitted in the winter of 1944/45 as the regiment patrolled the banks of the Maas river in Holland.

Information by Philip Greenwood

T17E1獵犬式裝甲車乃由美國雪佛蘭車廠於1941年設計並於1942年底投產。

雖然美國陸軍部取消了T17E1獵犬式裝甲車的訂單，但在整個第二次大戰中、後期英國及其聯邦國家卻廣泛使用。在荷蘭作戰之加拿大第12曼尼托巴騎兵部隊曾在其使用之獵犬式裝甲車砲塔上安裝了英國皇家空軍颶風式攻擊機所使用之60磅火箭彈，用來攻擊德軍部隊。

Im Juli 1941 arbeitete man bei Chevrolet an den Plänen zu einem geräumigen Panzerwagen mit Allradantrieb. Die Bezeichnung lautete T17E1 und der Typ wurde 1942 von den britischen sowie amerikanischen Streitkräften bestellt. Von den Engländern STAGHOUND genannt, hatte das 14-Tonnen Fahrzeug zwei GMC 6-Zylinder mit 97 PS und erreichte damit bis zu 89 km/h. Die maximale Panzerung betrug 32mm und als Bordkanone war eine 37mm M6 PaK installiert.

Kurz nach Produktionsbeginn im Oktober 1942 stornierte die US Army ihre Bestellung. So ging alles an die Briten als Führungs- und Aufklärungsfahrzeuge in Panzereinheiten. Einige Einheiten wie die 18th Canadian ACR (12th Manitoba Dragoons) setzten den STAGHOUND in Fronteinheiten ein. Dazu waren einige Fahrzeuge mit Vorrichtungen für Luft-Boden-Raketen ausgerüstet.

Die 12th Manitoba Dragoons waren dem Canadian 2nd Corps in Nordwest-Europa zugeteilt. Zum Einsatz kamen die raketenbestückten STAGHOUNDS 1944/45 an den Ufern der Maas in den Niederlanden.









ILLUSTRATION 圖示說明：

CORRECT METHOD FOR APPLYING DECALS : HINWEISE ZUM ANBRINGEN DER DECALS :

正確使用水貼紙方法：

1. Clean model parts surface with wet cloth. Entsprechende Stellen am Modell feucht reinigen. 將需要貼上水貼之部位表面擦乾淨*
2. Cut out the decal parts and dip them in cold water for 15 ~20 seconds. Decal ausschneiden und für 15-20 Sek. ins Wasser legen. 將所需之貼紙剪下泡在清水裏約15至20秒。
3. Place it on correct position of the model kit. Decal an der richtigen Stelle auflegen. 將濕透之貼紙取出置放於正確之位置旁。
4. Slide off the decal from the base paper on to the model kit surface with a cotton stick. Decal mit Wattestäbchen festhalten und Papier darunter wegziehen. 用棉花棒輕推貼紙表面使其從底紙滑出至模型表面之正確位置。
5. When decal get dry then complete. Decal mit Papiertuch andrücken und trocknen. 待其自然乾透後即完成。

ICON INSTRUCTION 圖標說明：

 Open hole Loch bohren 鑽孔	 Remove Abtrennen 切除	 2 sets needed Vorgang wiederholen 同樣的製作二組	 Bend Biegen 曲折	 Optional Auswahl 可以選擇採用
 Apply decal Decal anbringen 貼上水貼紙	 Instant glue for metal Sekundenkleber verwenden 瞬間接著劑，金屬用	 Fill hole Verspachteln 把孔填平	 Do not cement Nicht kleben 不用黏合	

COLOUR GUIDE : FARBTABELLE : 塗色指示：

Colour: Overall US Olive Drab No.9
全車塗美式橄欖褐色No.9

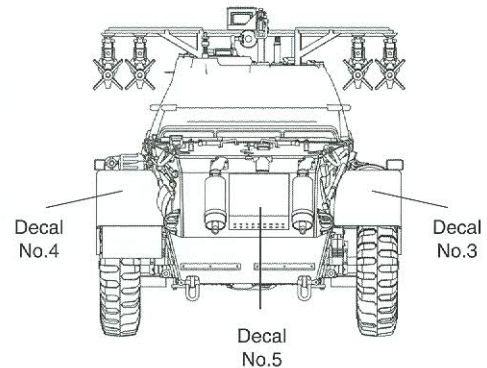
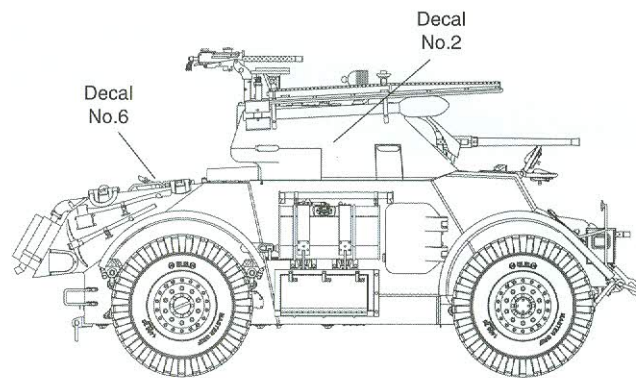
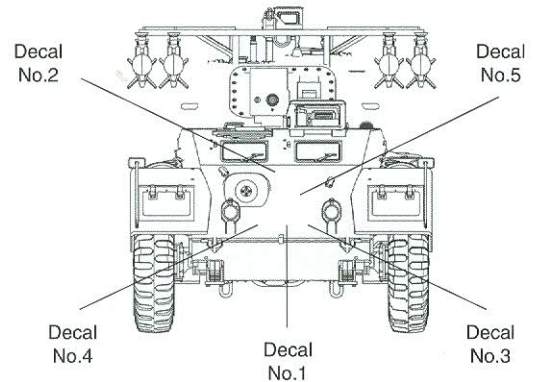
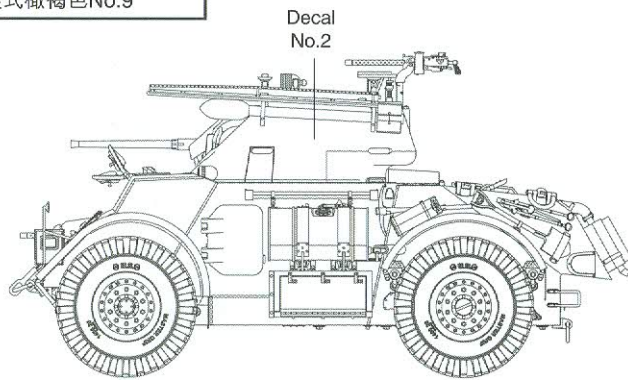

12th Manitoba Dragoons, II Canadian Corps Armoured Car Regiment, Belgium, 1944 Winter
1944年冬天在比利時作戰之加拿大第II裝甲旅屬下車輛

COLOR SUGGESTION : FARBTABELLE : 塗裝指引：

Gunze Sangyo	Hobby Color	Gunze Sangyo	Hobby Color	Humbrol	Tamiya
Khaki Green Khaki Grün	卡其綠	H-80	C-54	/	/
Red Rot	紅色	H-3	C-3	19	X-7
Silver Silber	銀	H-8	J-8	11	/
British Olive Drab Britisch Oliv Nr. 15	英式橄欖褐	H-52	C-12	163	XF-58
Dark Green Dunkelgrün	深綠	H-36	C-17	/	XF-61
Tire Black Reifenschwarz	輪胎黑	H-77	C-137	85	XF-1
Steel Stahl	黑鐵	H-18	C-28	53	/
Burnt Iron Metall brüniert	燒鐵色	H-76	C-61	/	/
Wood Brown Holzbraun	木啡色	H-37	C-43	/	/
Field Green Feldgrün	田野綠	/	/	69 70%+ 33 30%	/
Flat Black Mattschwarz	消光黑	H-12	C-33	33	XF-1
Orange Orange	橙色	H-14	C-59	18	X-6
US Olive Drab No.9 U.S. Oliv Nr. 9	美式橄欖褐	H-52	C-304	/	XF-62
Sand Sandfarbe	沙黃色	H-79	C-39	64	XF-59
Bronze Green Bronzegrün	銅綠色	/	/	30	/
Sand Grey SandfarbeGrau	沙灰色	H346 70% + H345 30%	/	63 + 64	XF-59+XF66

PARTS LIST 零件展示表：

READ BEFORE ASSEMBLING

- * Carefully Study instruction before assembling. Anleitung studieren und verständlich machen. 組裝前請閱讀清楚製作指引。
- * Keep plastic model glue and tools away from children. Kleber, Farben, Werkzeuge und Plastiktüten von Kindern fernhalten. 膠水，油漆及工具勿讓小孩接觸。
- * Do not use cement or paint near open flame or sparks. Kleber/Farbe nicht in Nähe von offenen Flammen. 膠水及油漆勿接觸火種。
- * Do not work in closed room. Nur in ausreichend belüfteten Räumen arbeiten. 勿在密封地方製作模型。



Bronco Models

Copyright©2008
Made in China
中國製造

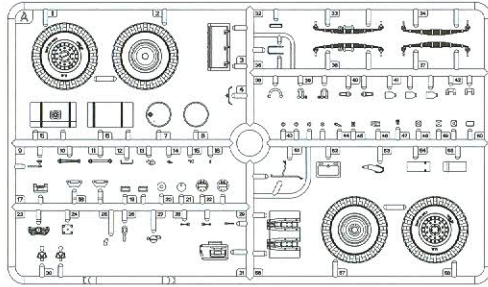

Ax2

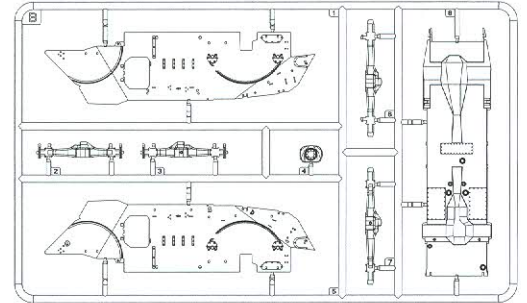

Bx1

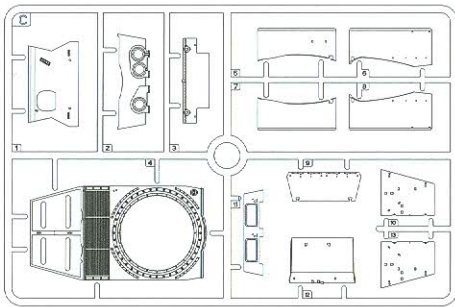

Cx1

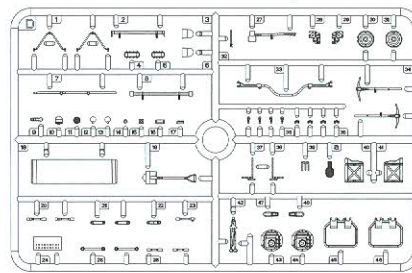

Dx1

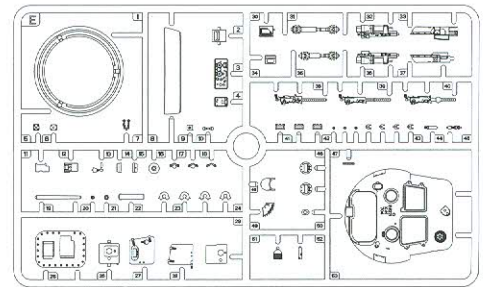

Ex1

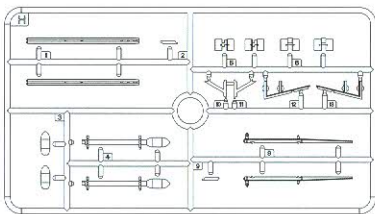

Hx1

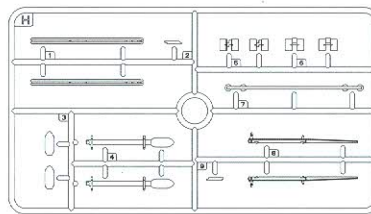

Hx1

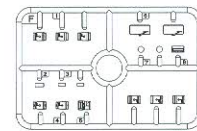

Fx1

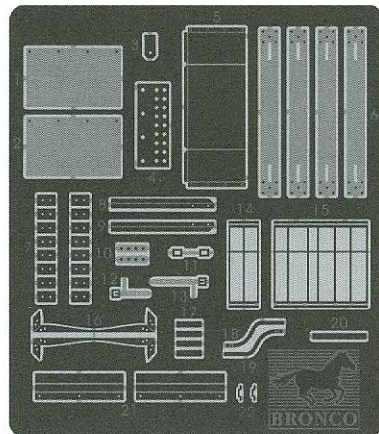

Px1



XPx1



X1

ILLUSTRATION 圖示說明：

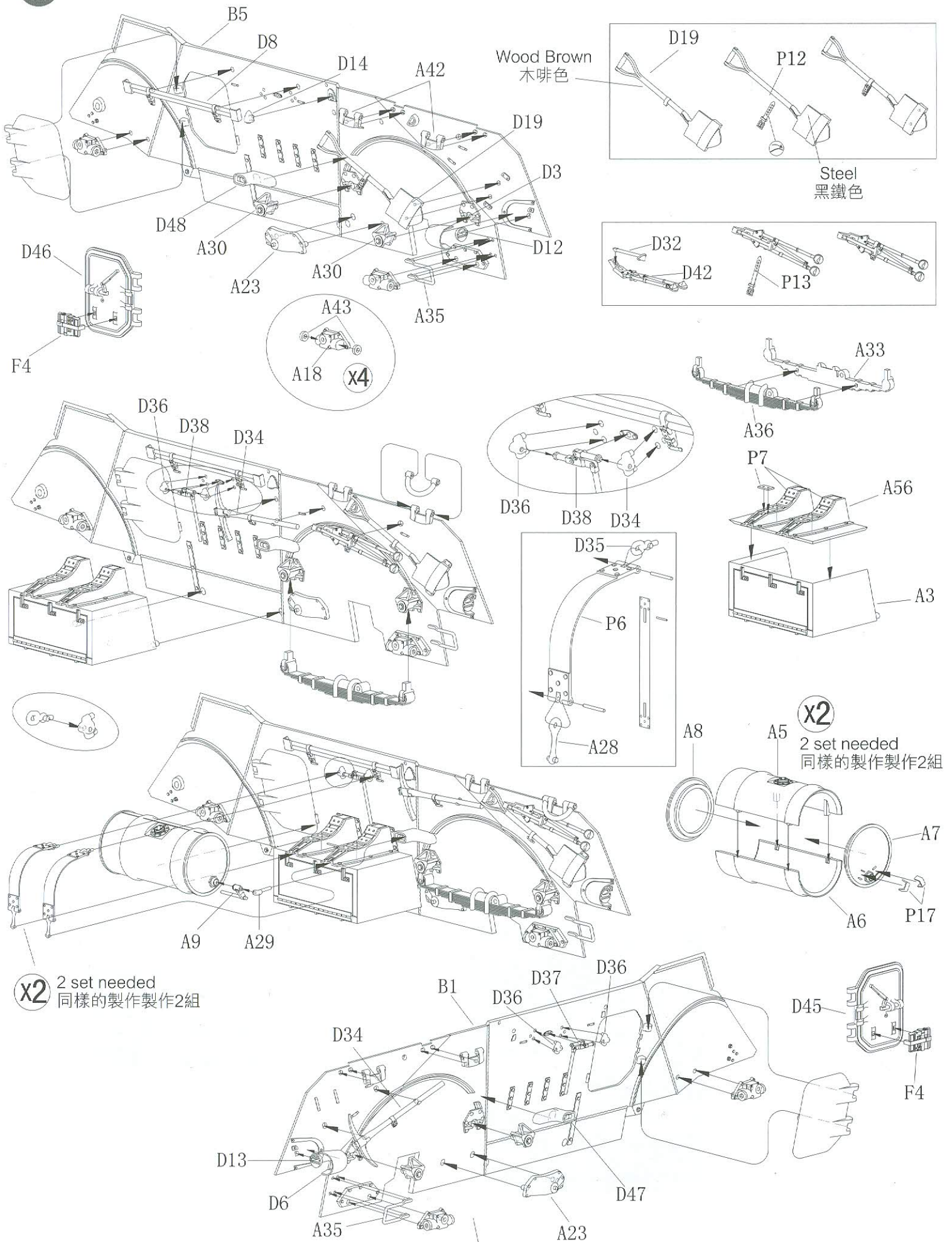

ILLUSTRATION 圖示說明：

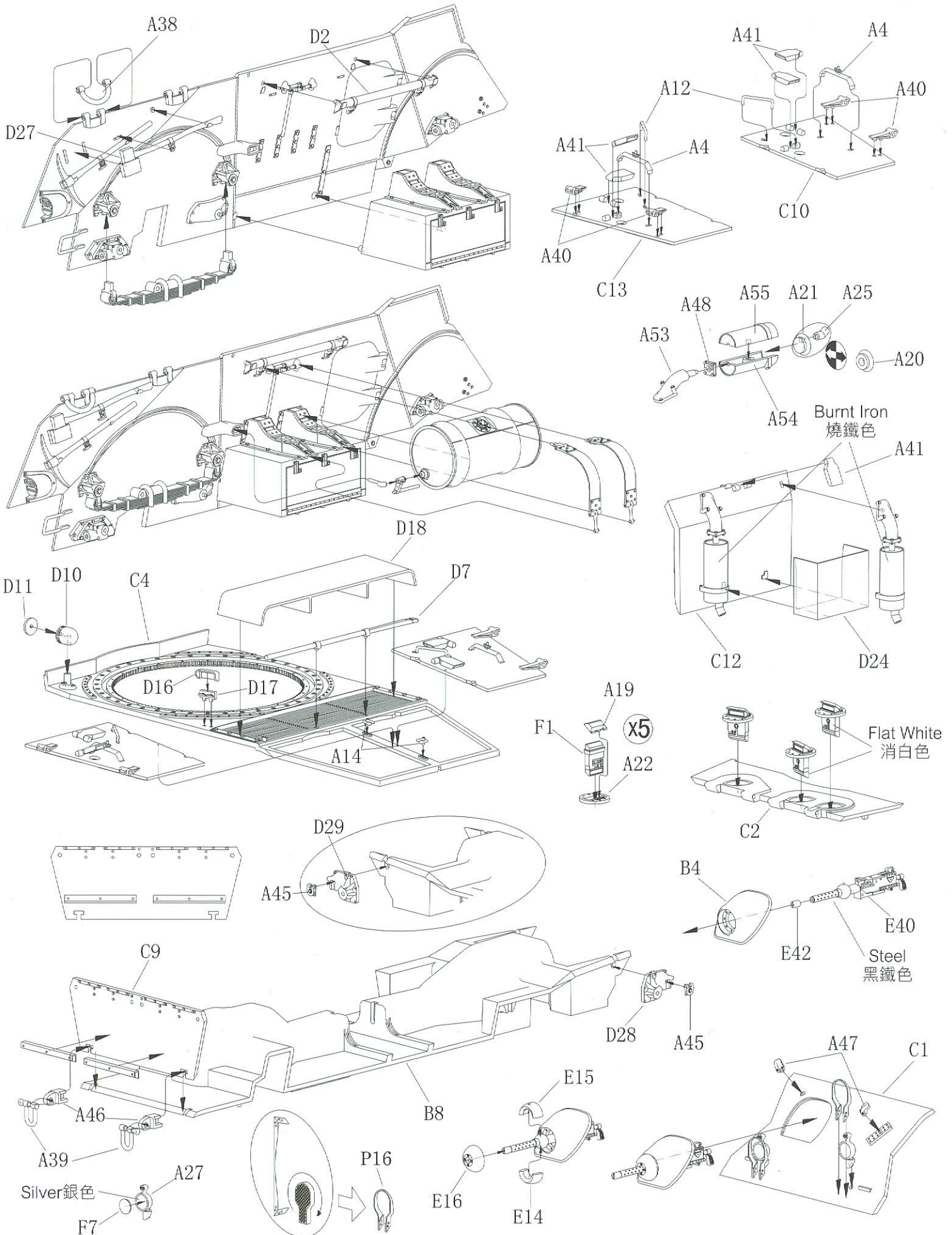

ILLUSTRATION 圖示說明：

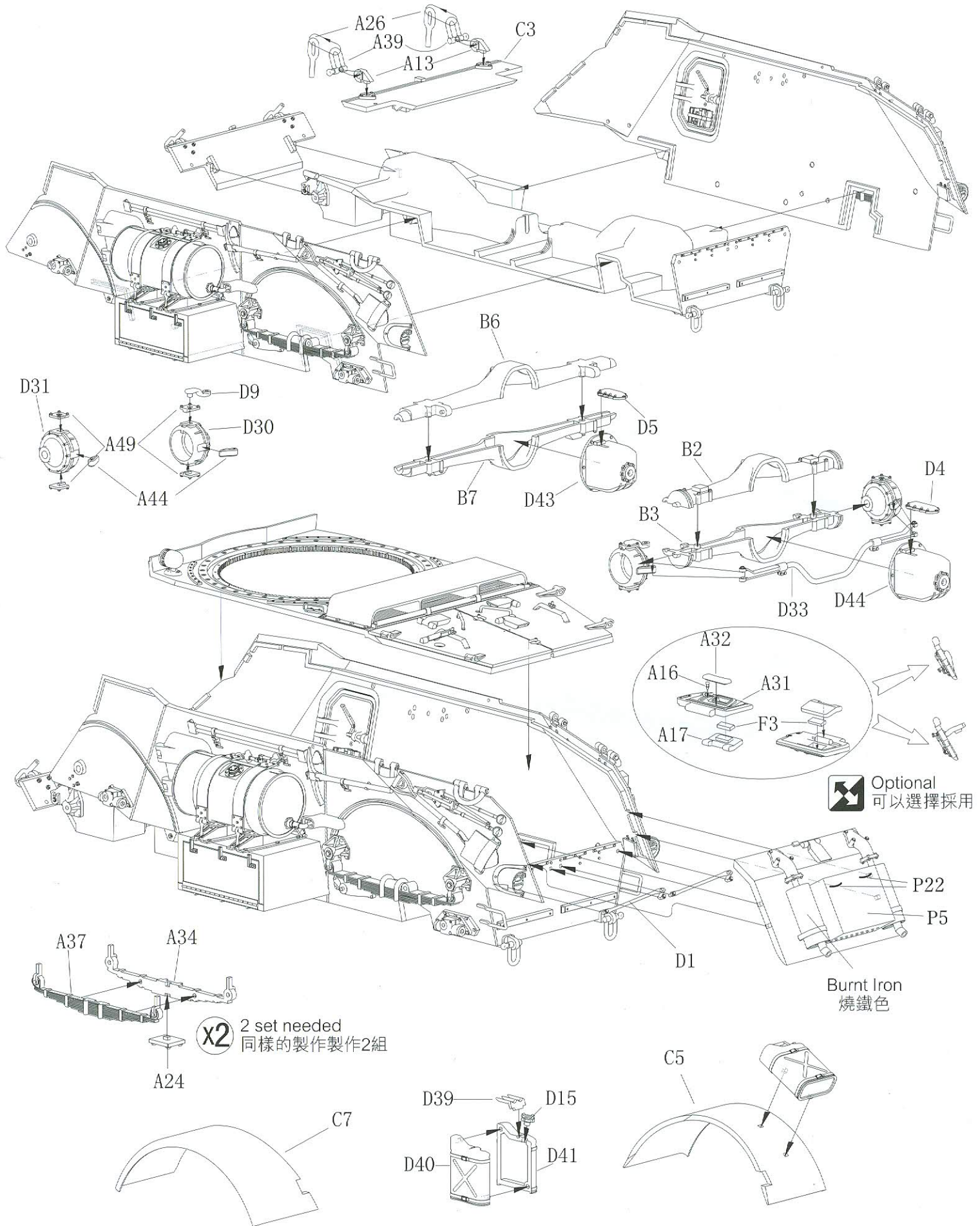

ILLUSTRATION 圖示說明：

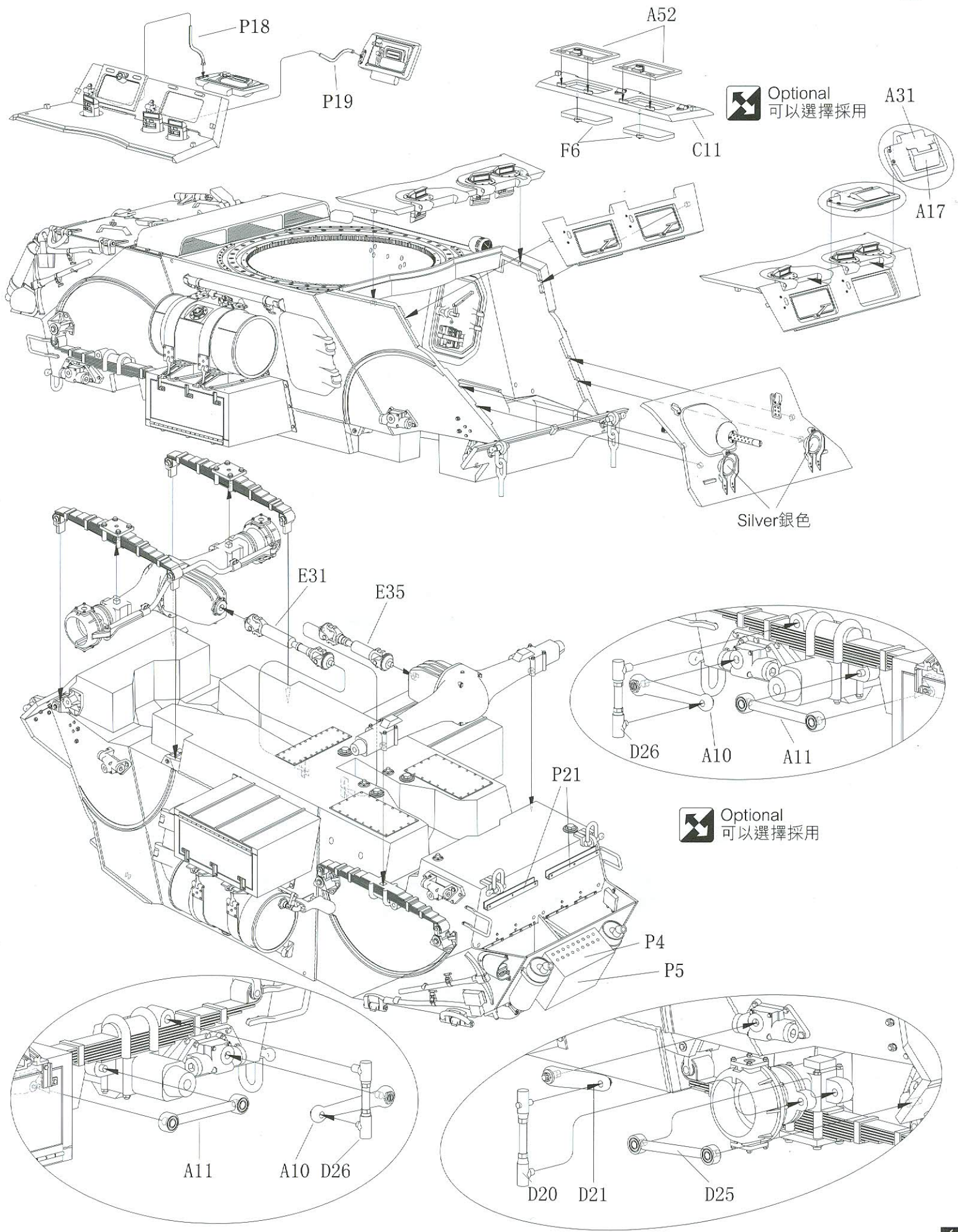

ILLUSTRATION 圖示說明：

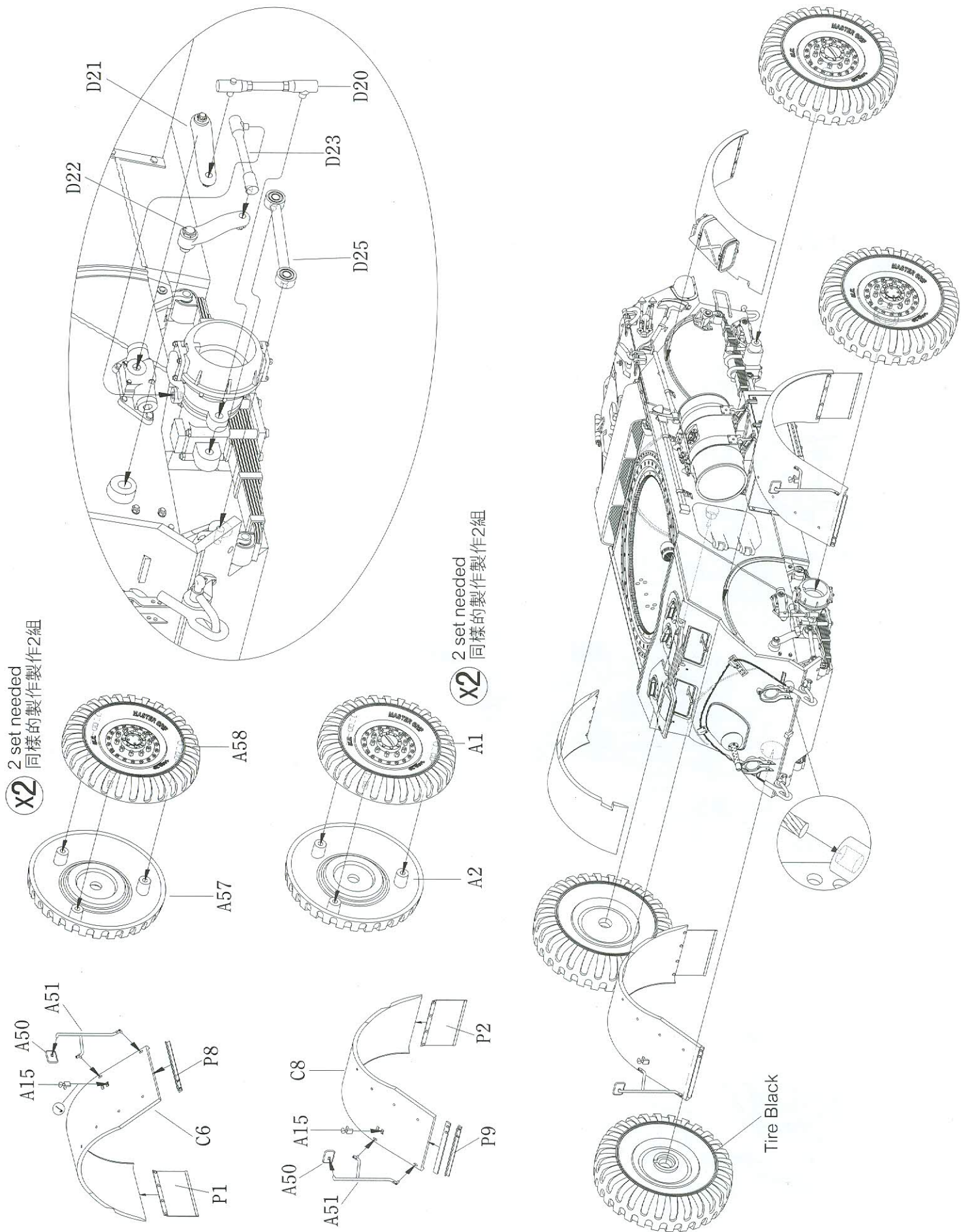

ILLUSTRATION 圖示說明：

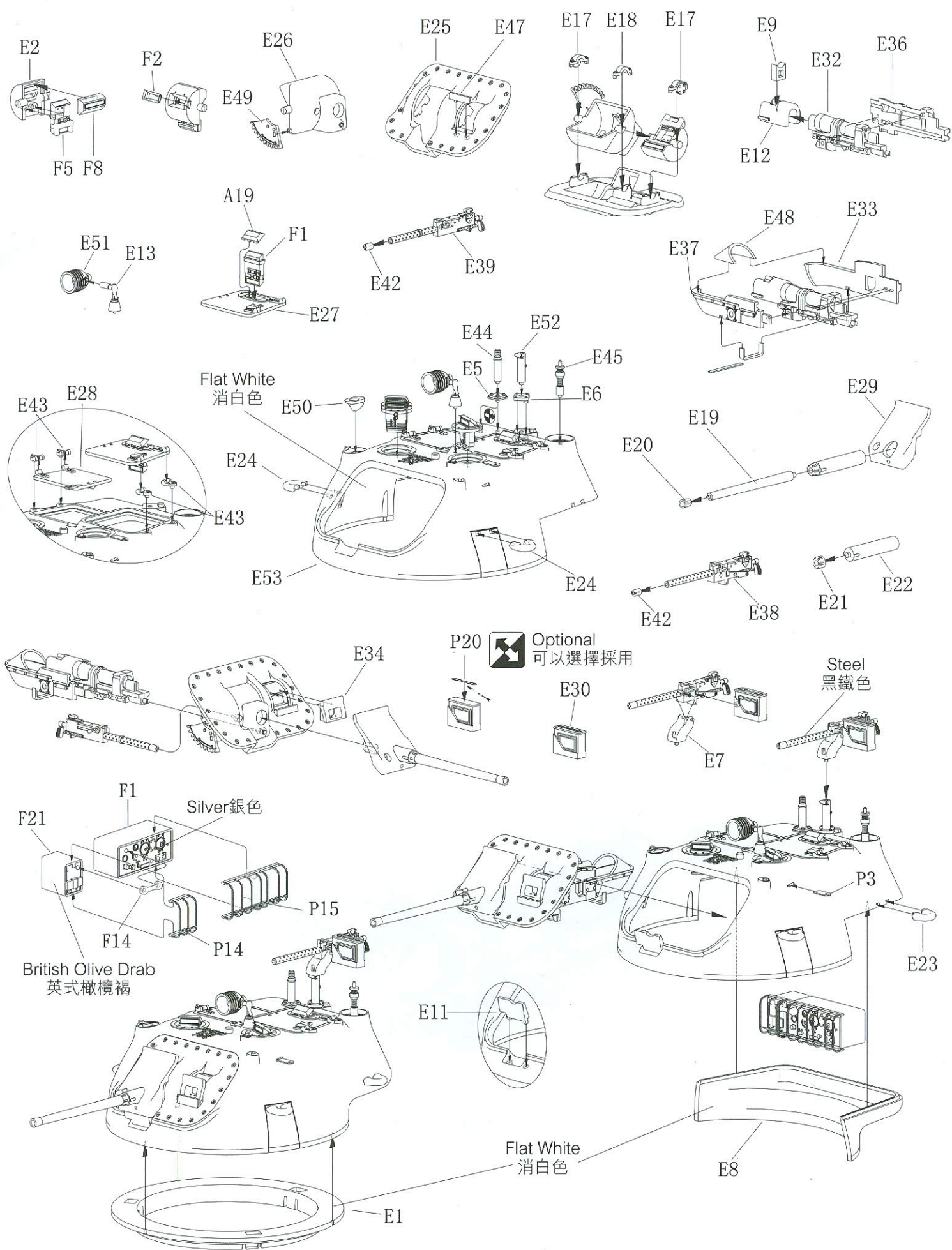
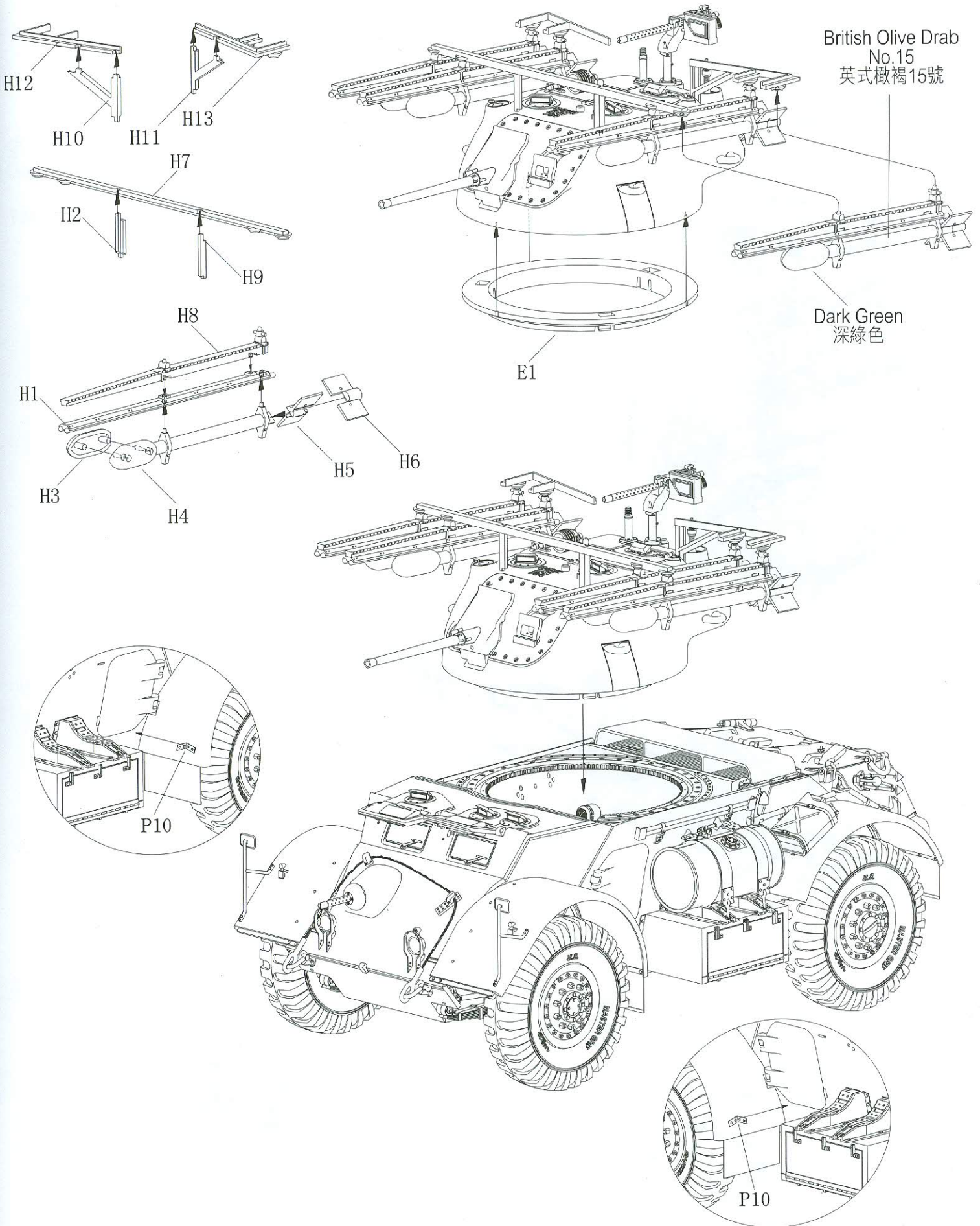

ILLUSTRATION 圖示說明：



* Special thanks to the Mr. Phillip Greenwood, Dick Taylor & Michael Knoblich for the information research.