



USER MANUAL

产品安装说明书

PH 35023



1/35 scale

Kurganets-25 IFV(OBJECT 695)

庫爾干人-25步兵戰車 “695工程”

READ BEFORE ASSEMBLY

组装前请仔细阅读

1. Study and understand these instructions thoroughly before beginning assembly
组装前请仔细阅读以下内容
2. When needed, remove photo-etch parts carefully using a modeling knife or photo etch sprue cutter, be careful not to damage or lose small parts
请使用专业模型工具仔细去除蚀刻片或胶件上需要剪下的部分，小心不要损坏或丢失
3. Take extra care in handling photo etch parts in order to avoid injury
在处理蚀刻片的部分时请格外小心，以避免伤害
4. Apply instant cement sparingly to photo etch parts were instructed
用强力快干胶水粘合蚀刻片零件和金属轴，过量使用快干胶水可能导致可动零件粘住，小心涂胶
5. Tools recommended(not included in kit): Plastic and instant cements, sprue cutters, long nose pliers, modeling knife, small files, tweezers, pin vise & scissors. Soft cloth and sandpaper will also assist in construction
推荐模型工具(自备): 胶水、水口剪刀、长咀钳、刀片、锉刀、镊子、钳、钻、剪刀、瞬间快干胶
6. Glue and paint are not included in the kit. Use plastic cement and hobby paints only. Color guide for purchasing paint is included in the kit.
软布与砂纸同时也应该是必备工具，请使用塑料胶水和油漆(模型内不含)

ICON INSTRUCTION

图标说明



Optional
选择



Bending
折弯



Do not stick
不涂胶水



Decal
水贴纸



Remove
切除



Drilling
钻孔



Fill
填补



Weight
配重

车面

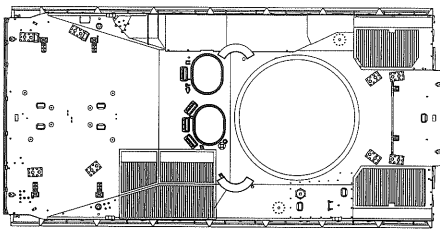

车底

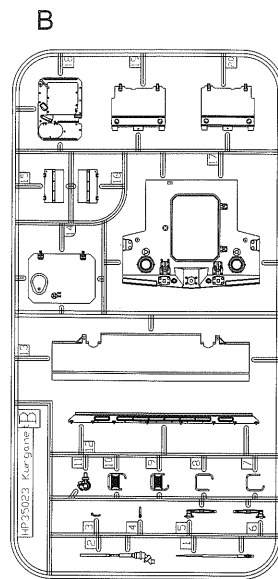
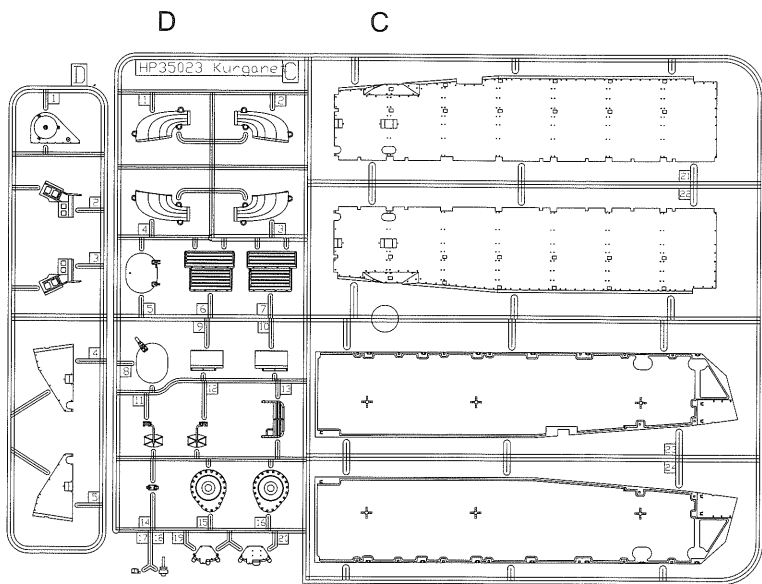
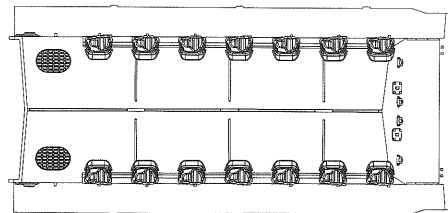

H X 2

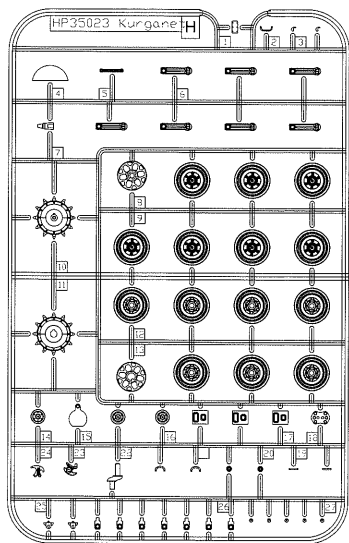

E

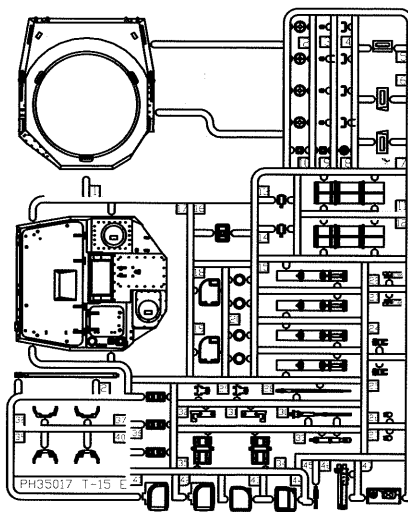

G X 2

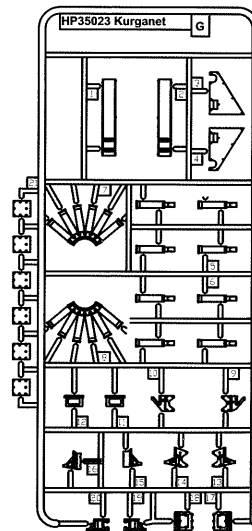

T X 12



T X 6

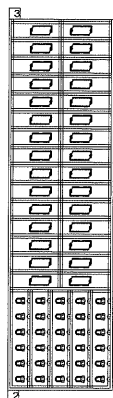

GP
透明件

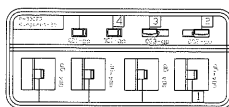

Decal
水贴

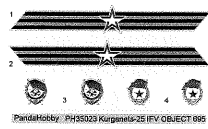

PE
蚀刻片

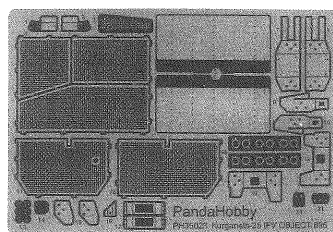

ASSEMBLY
模型组装

1

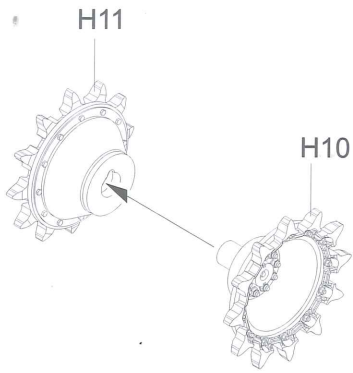

《主动轮》
Sprocket wheel
制作两组
Make two

ASSEMBLY
模型组装

2

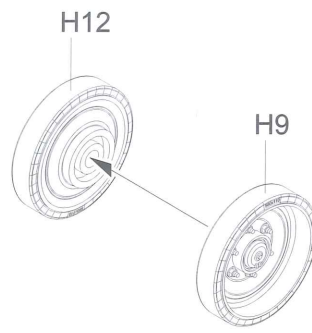

《负重轮》
Road wheel
制作十四组
Make fourteen

ASSEMBLY
模型组装

3

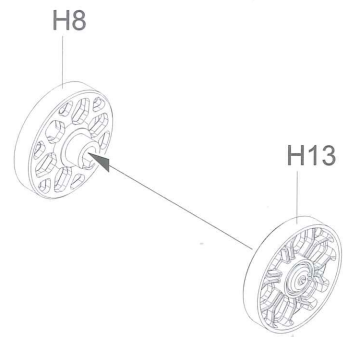

《从动轮》
Driven wheel
制作两组
Make two

ASSEMBLY
模型组装

4

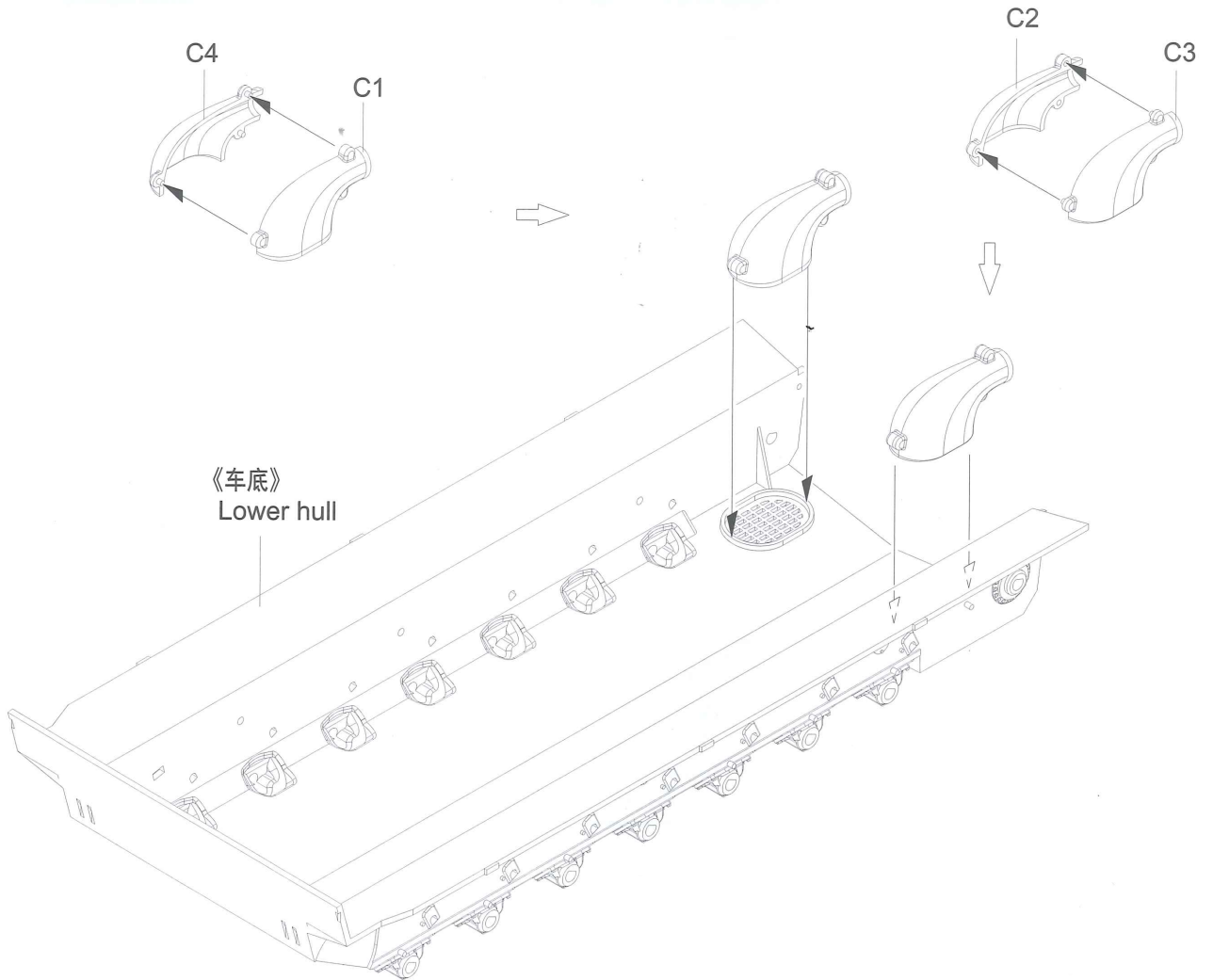

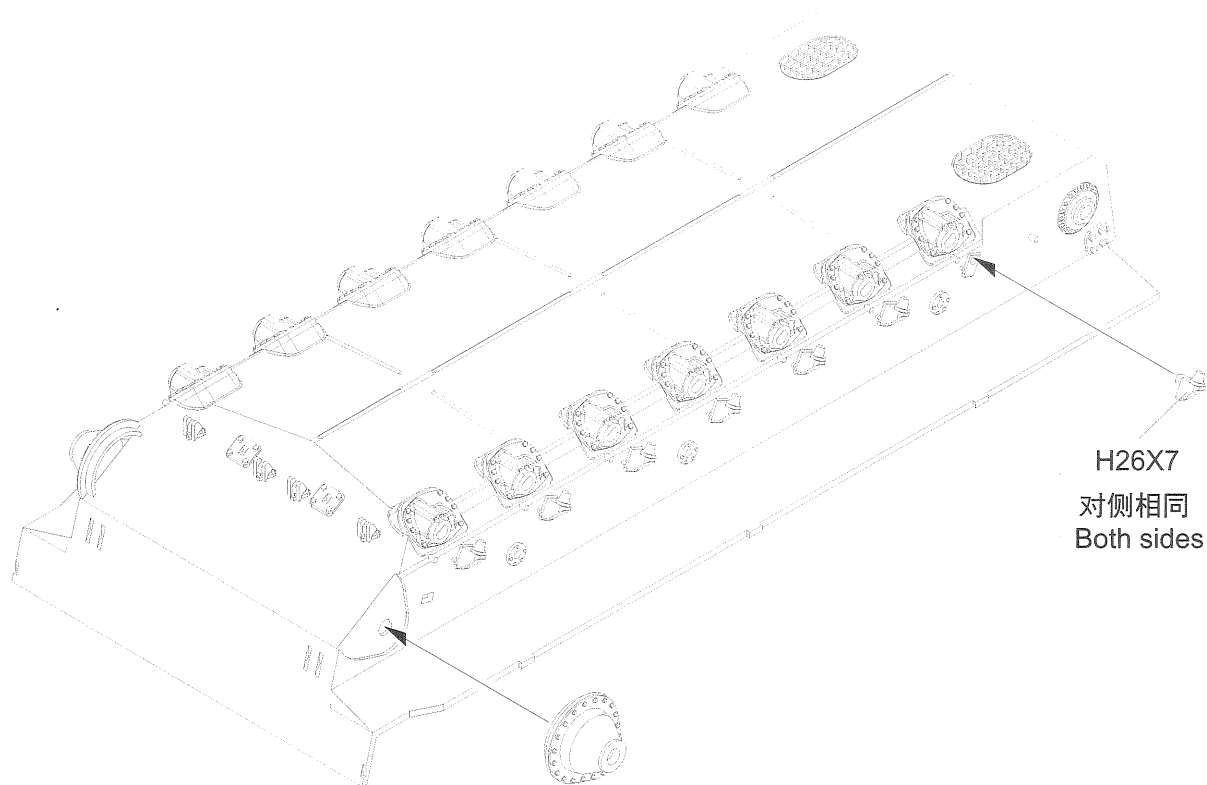

H26X7
对侧相同
Both sides

C15
对侧C16
Opposite C16

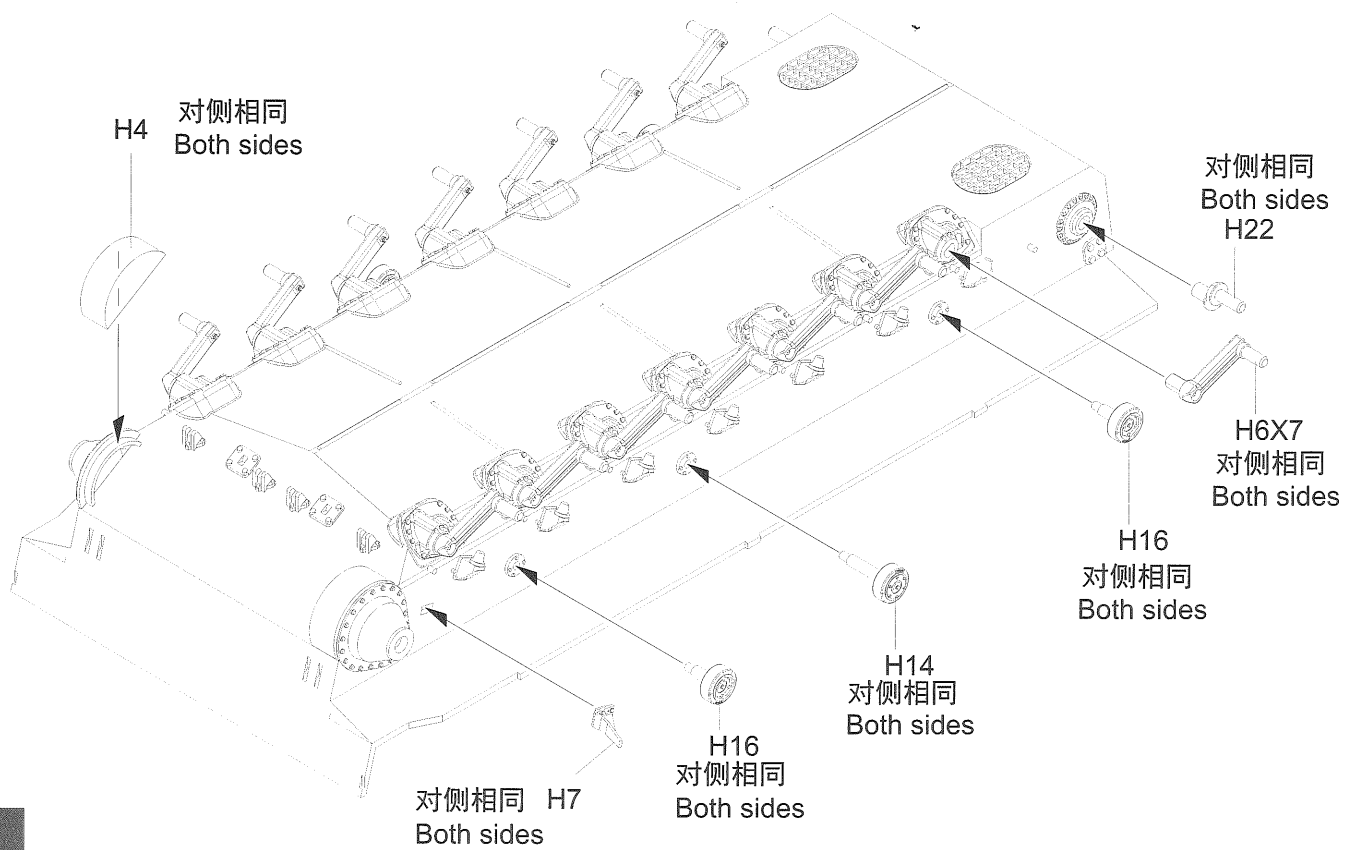

H4
对侧相同
Both sides

对侧相同
Both sides
H22

H6X7
对侧相同
Both sides

H16
对侧相同
Both sides

H14
对侧相同
Both sides

对侧相同 H7
Both sides

H16
对侧相同
Both sides

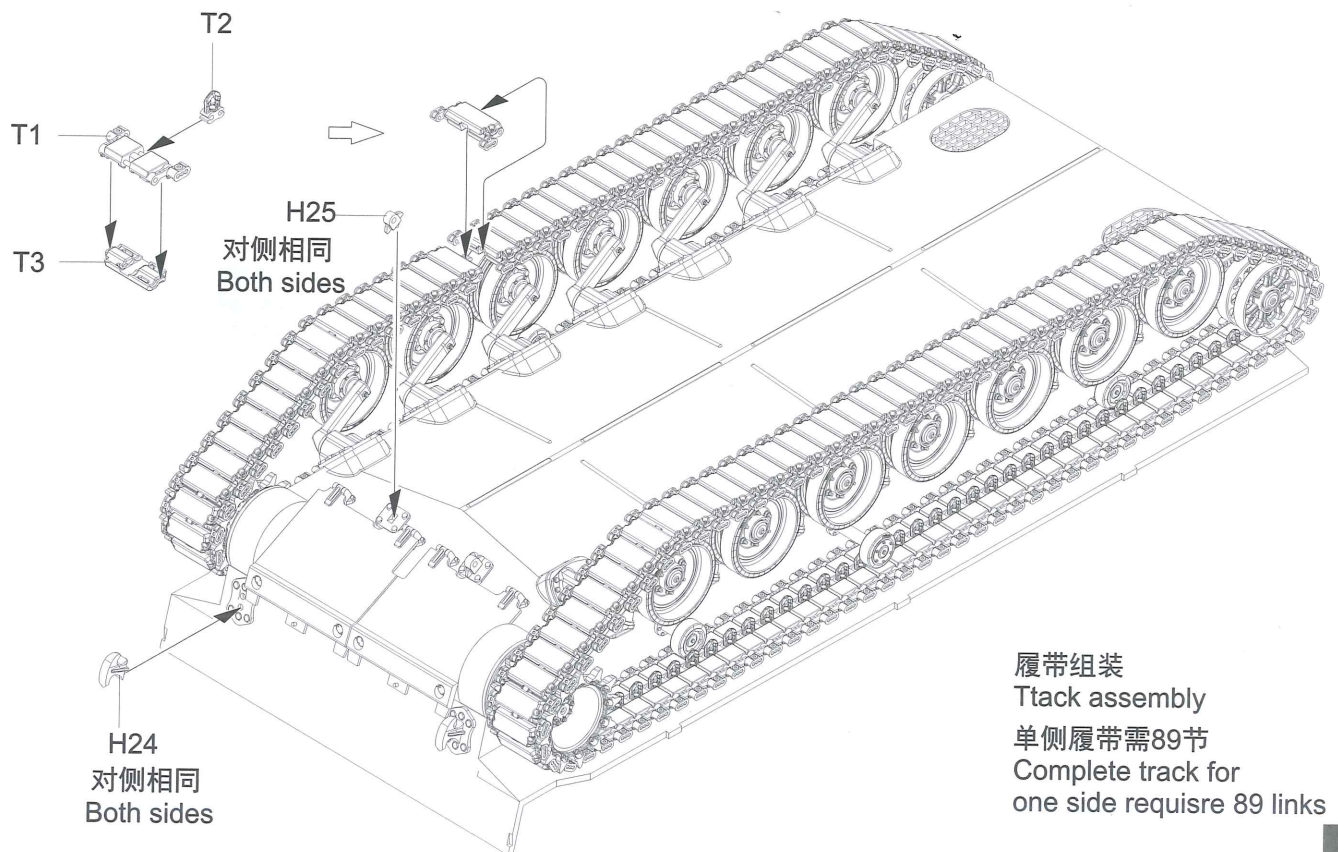
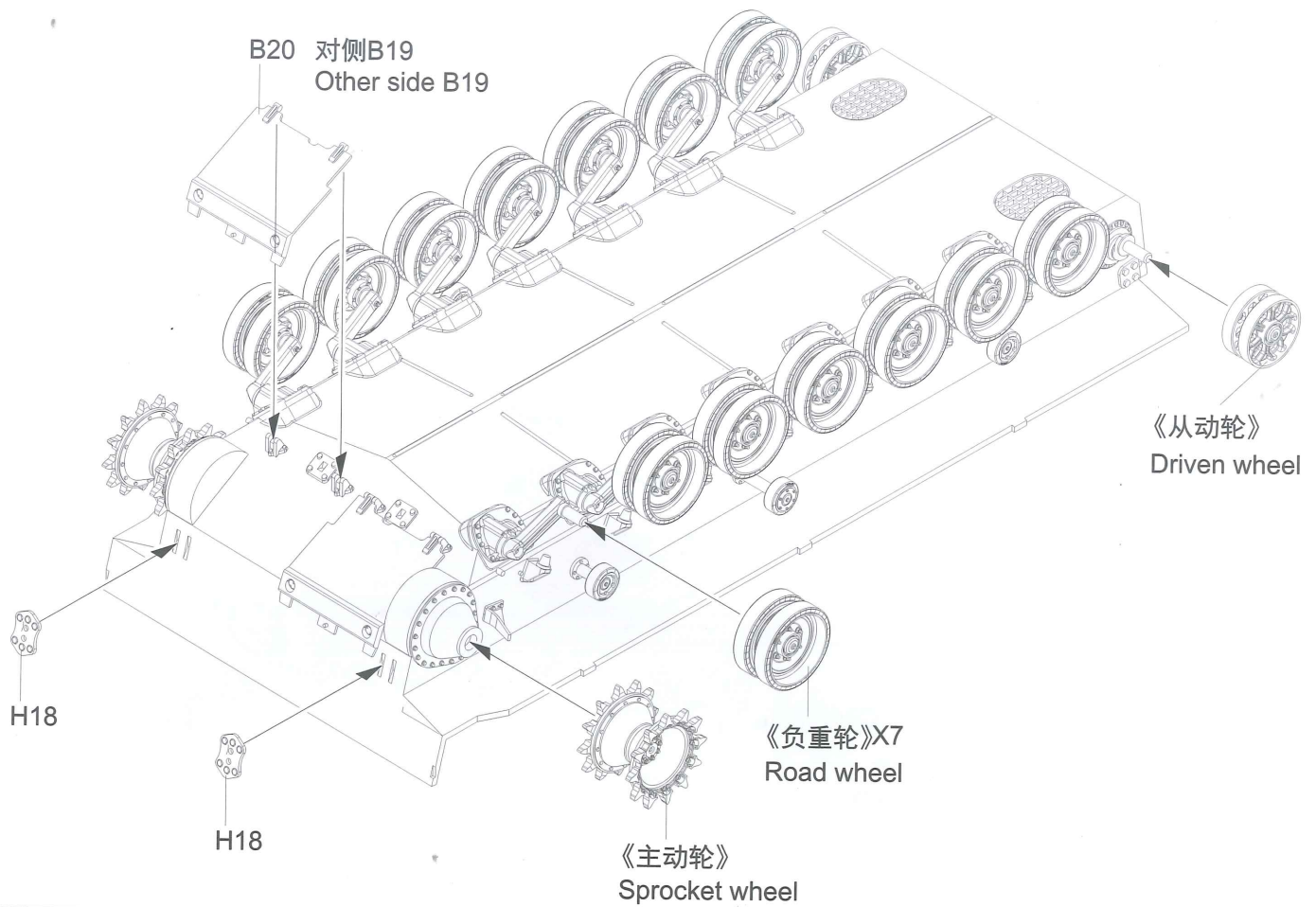

履带组装
Track assembly
单侧履带需89节
Complete track for
one side require 89 links

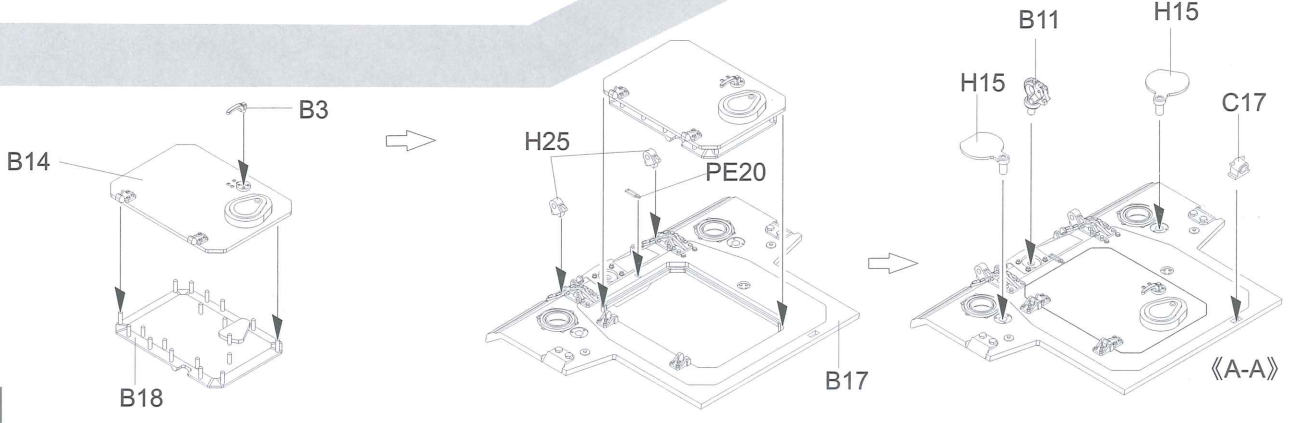
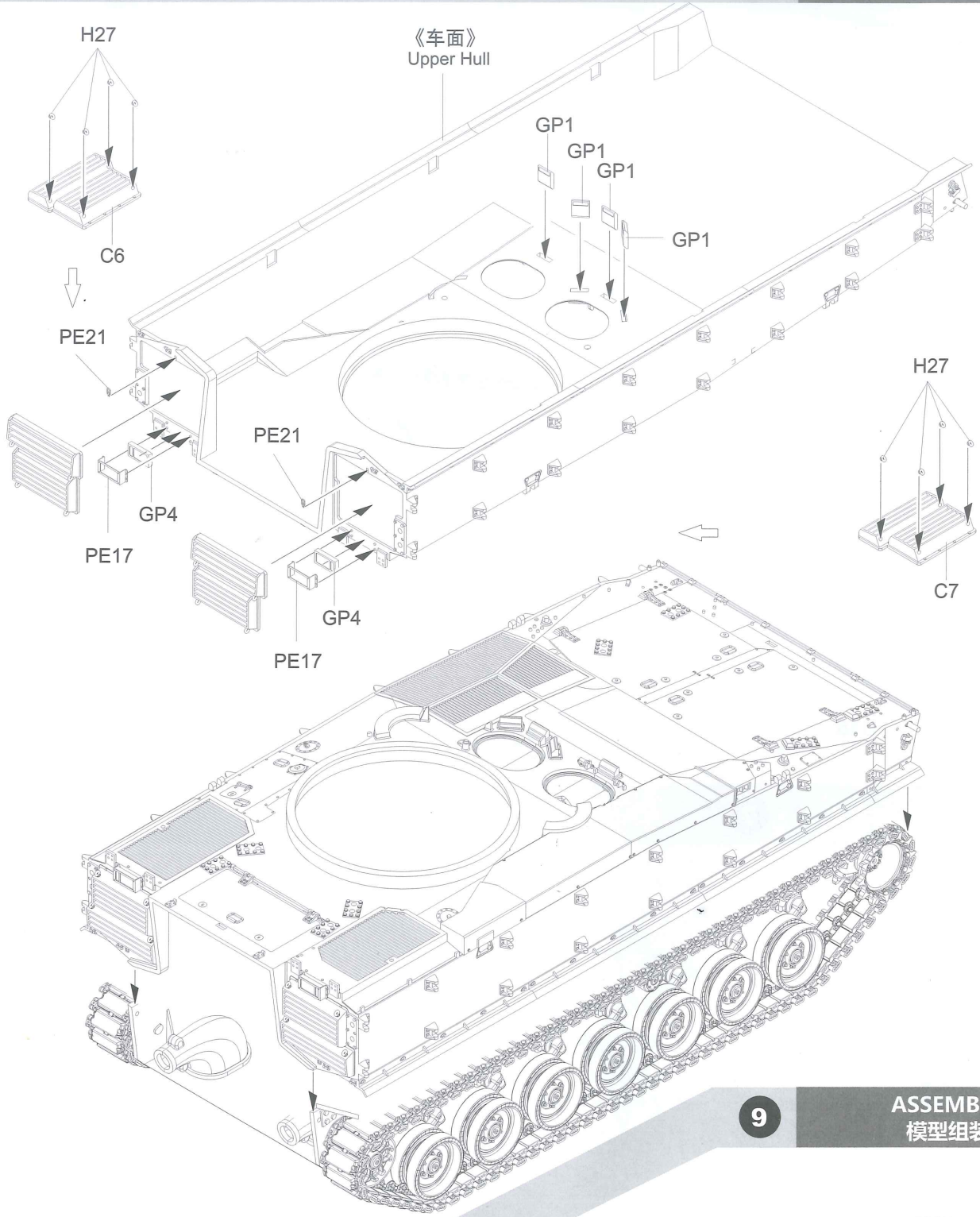

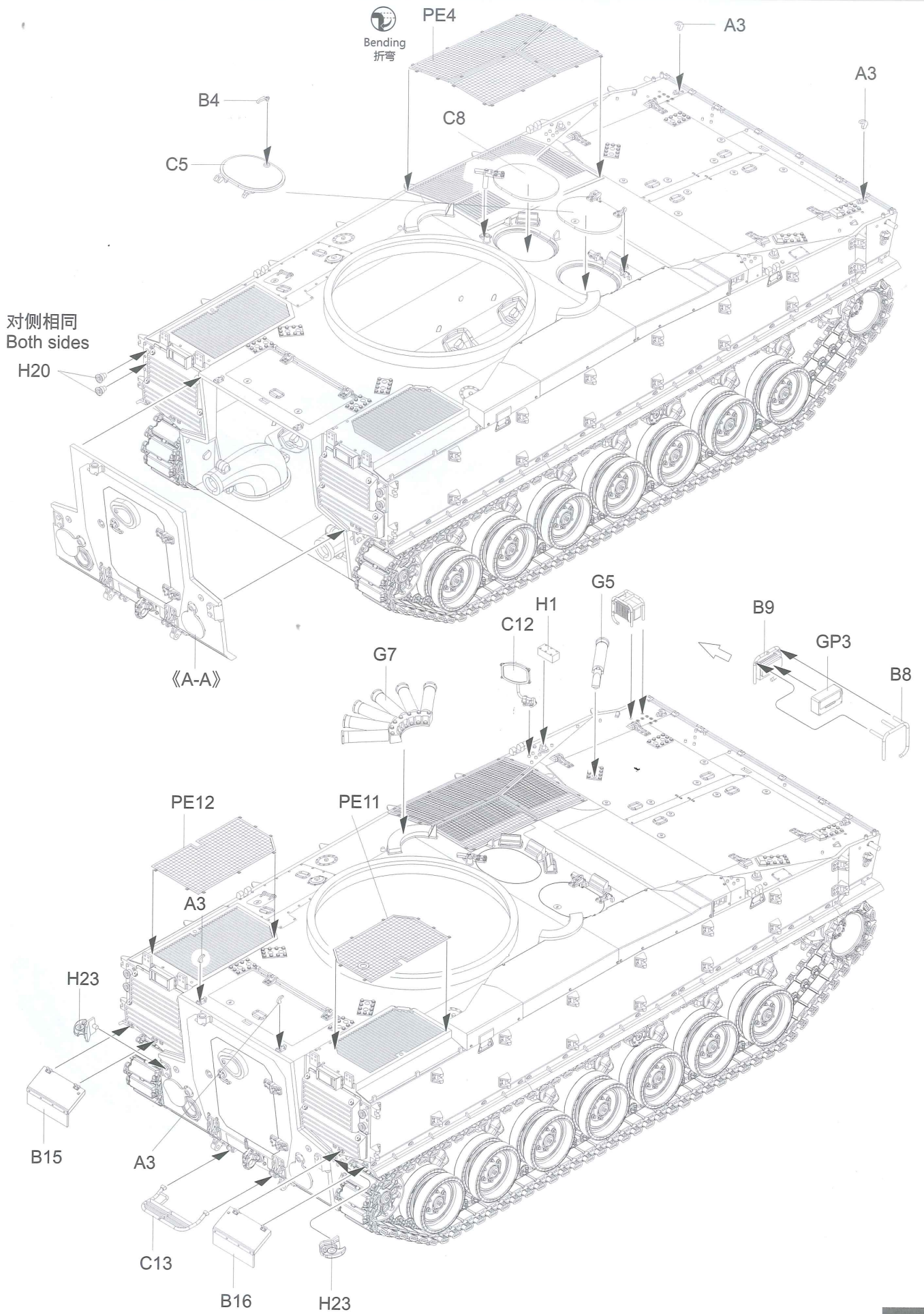

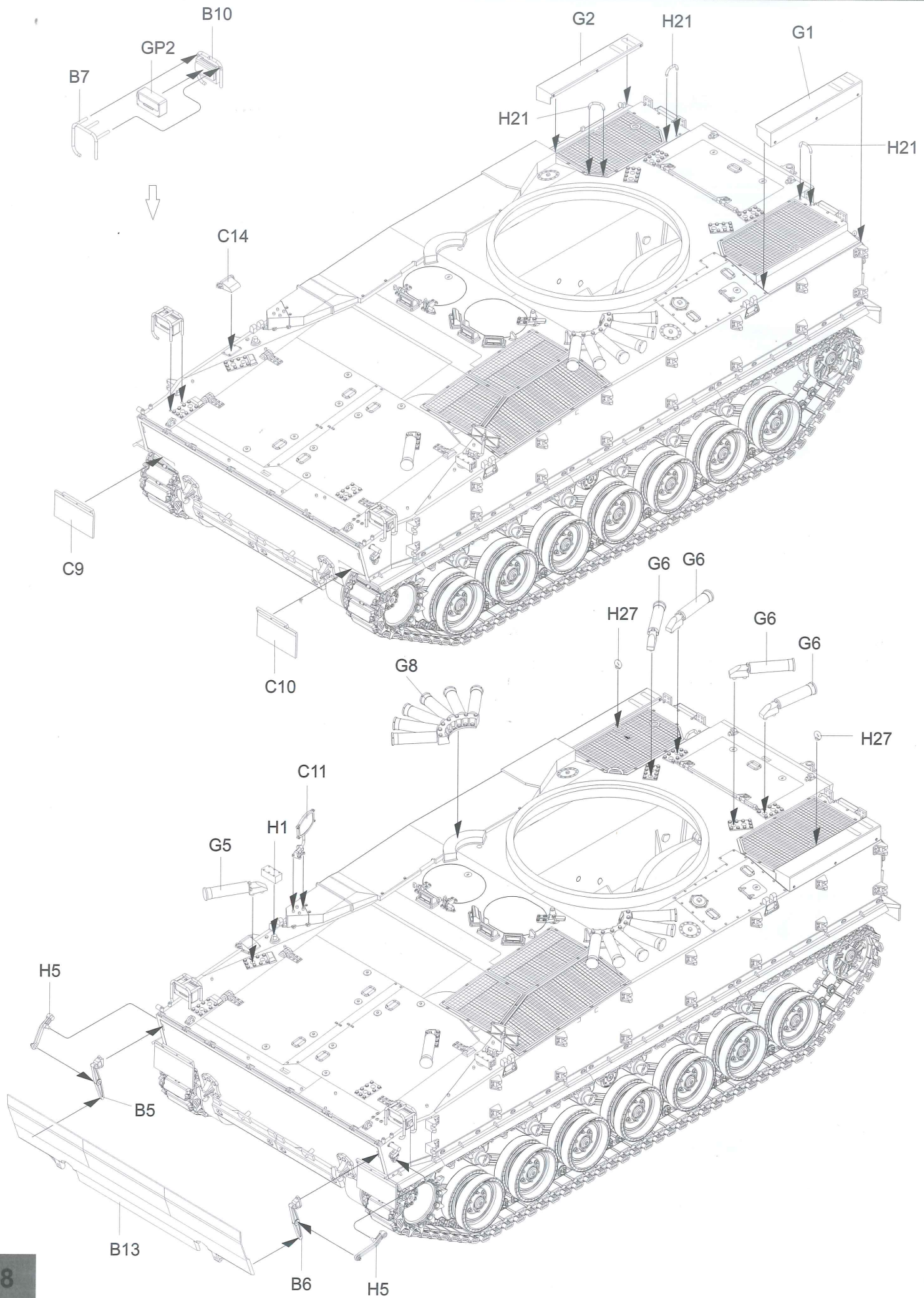

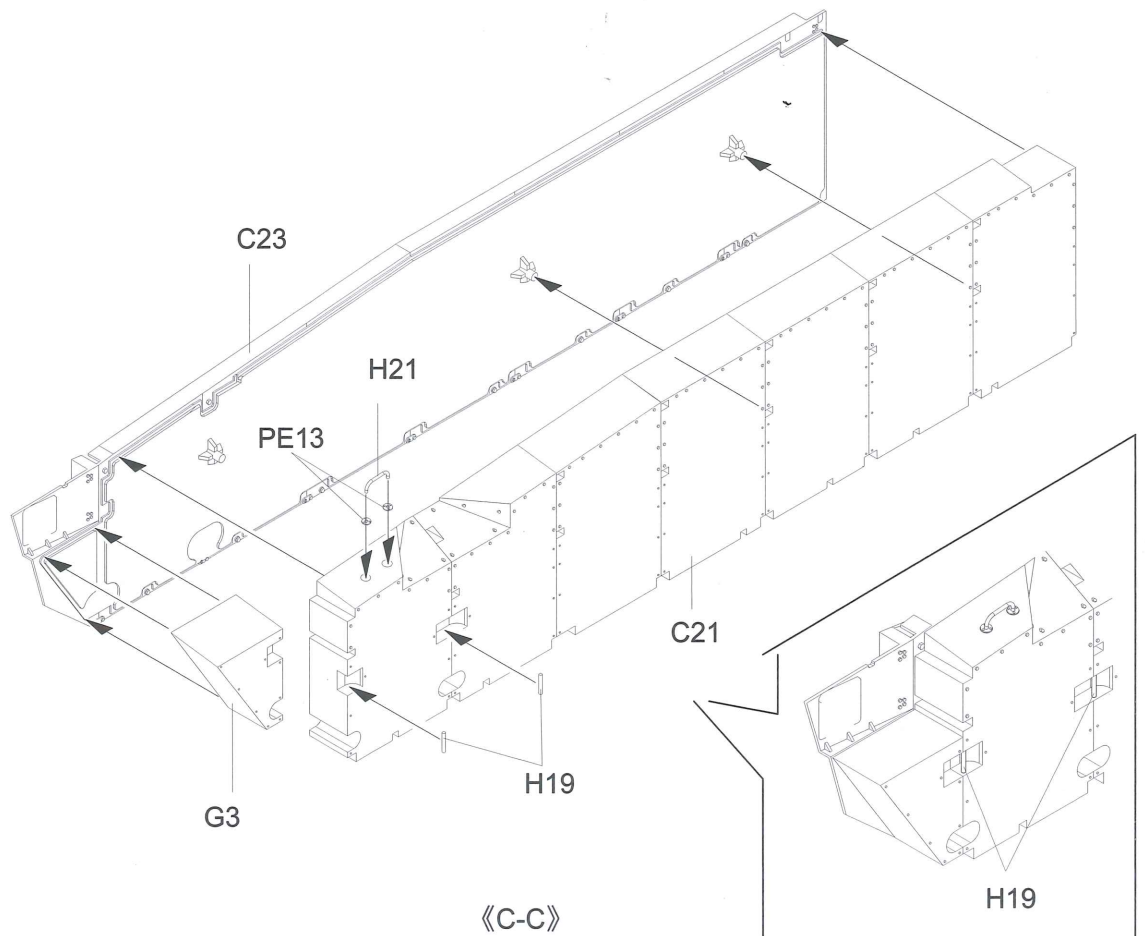
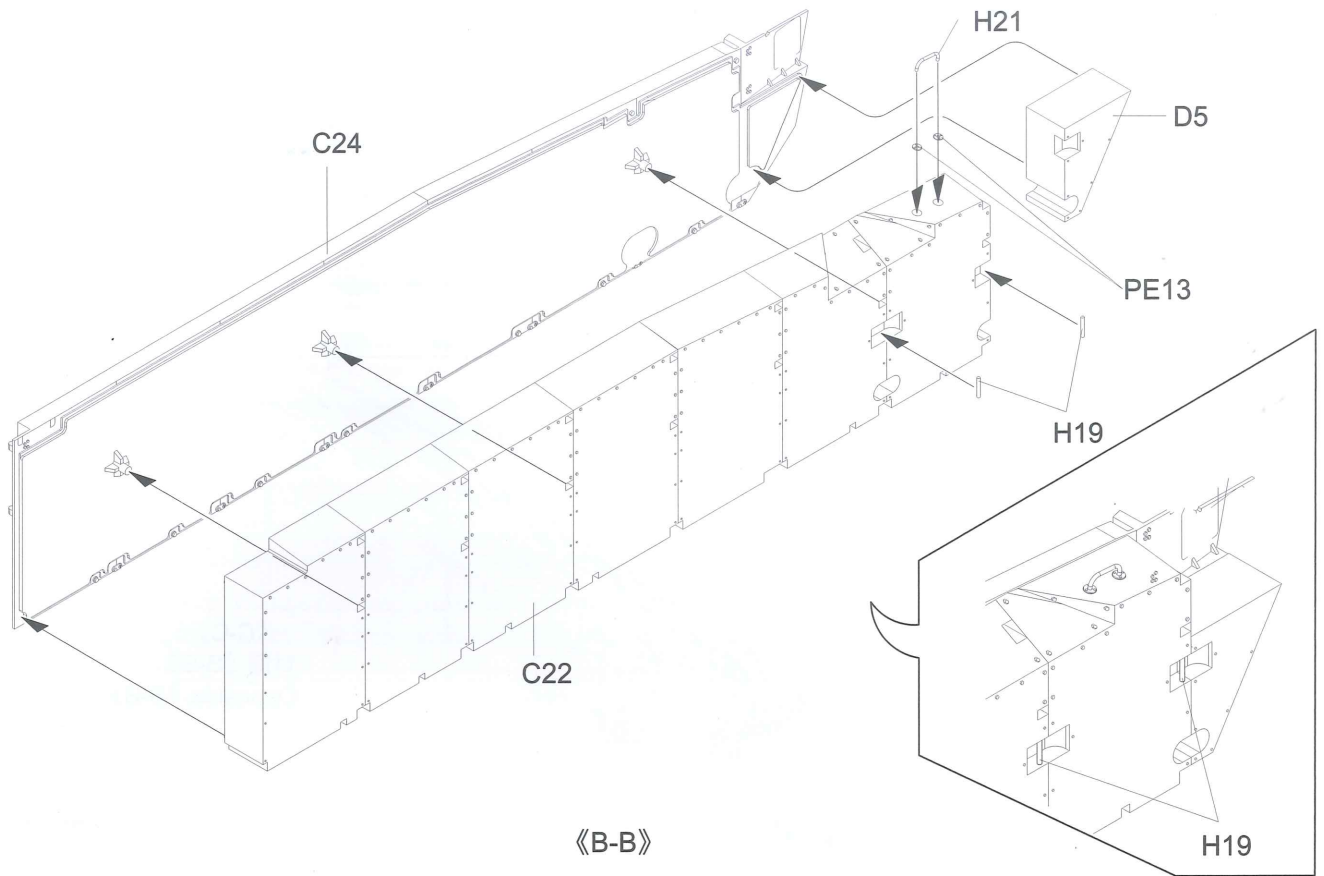

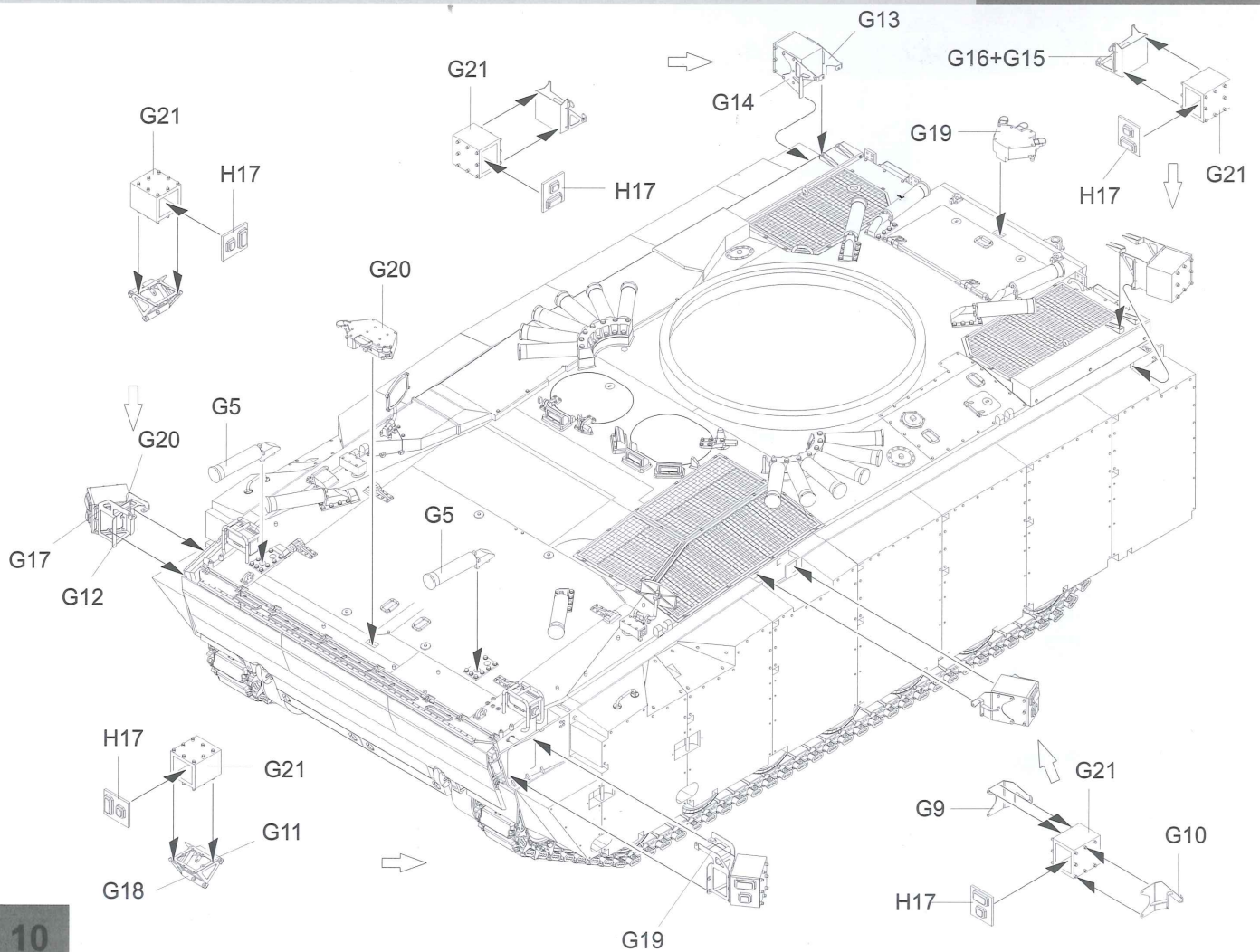
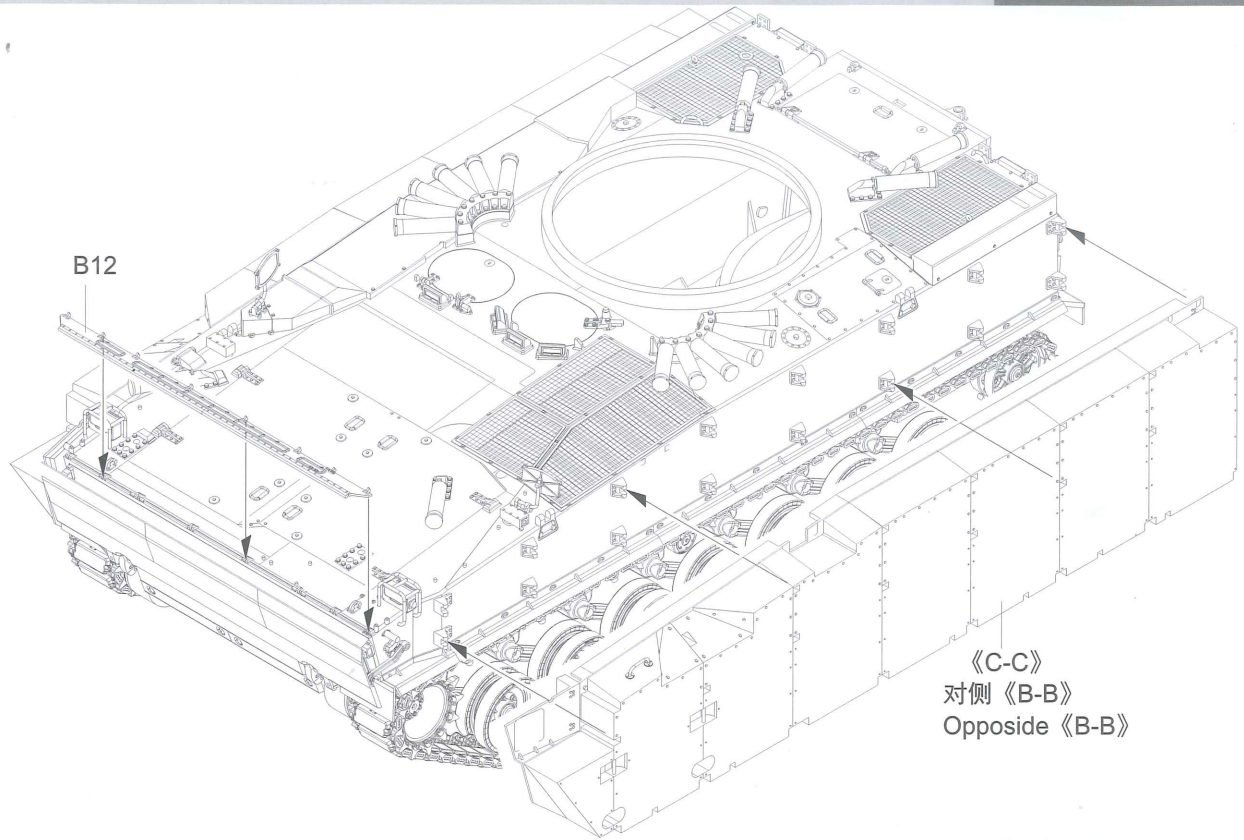

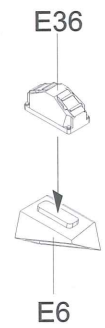
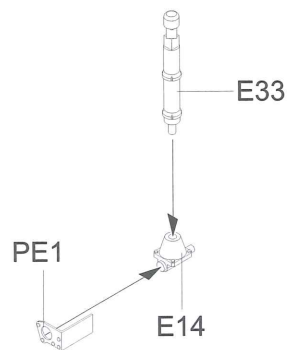
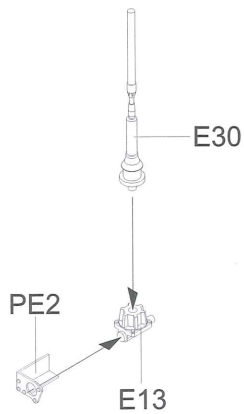
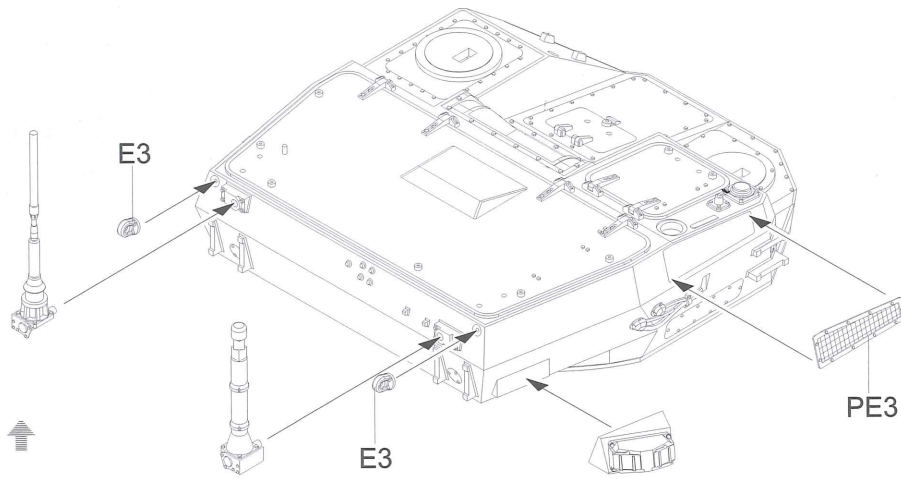
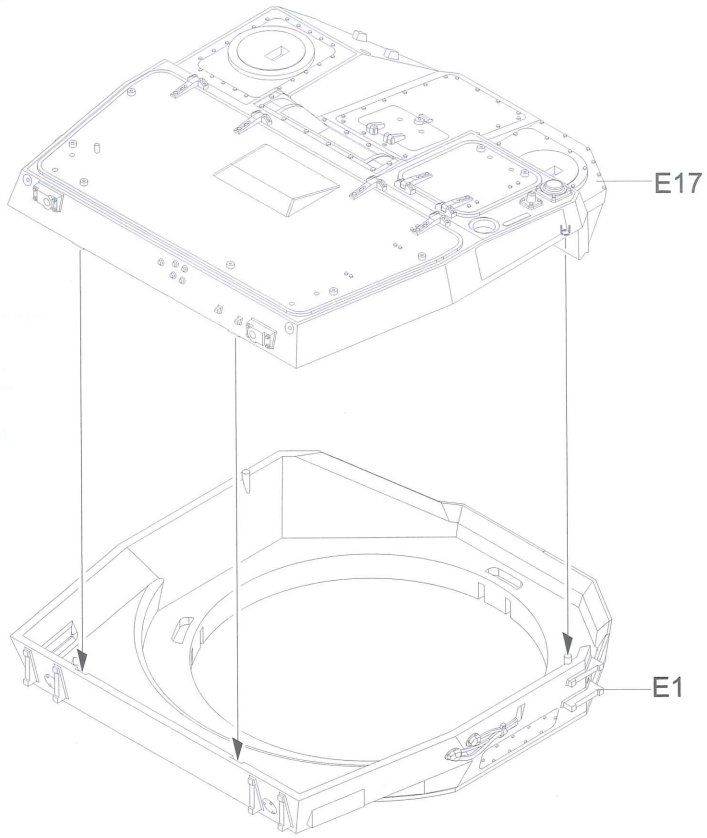

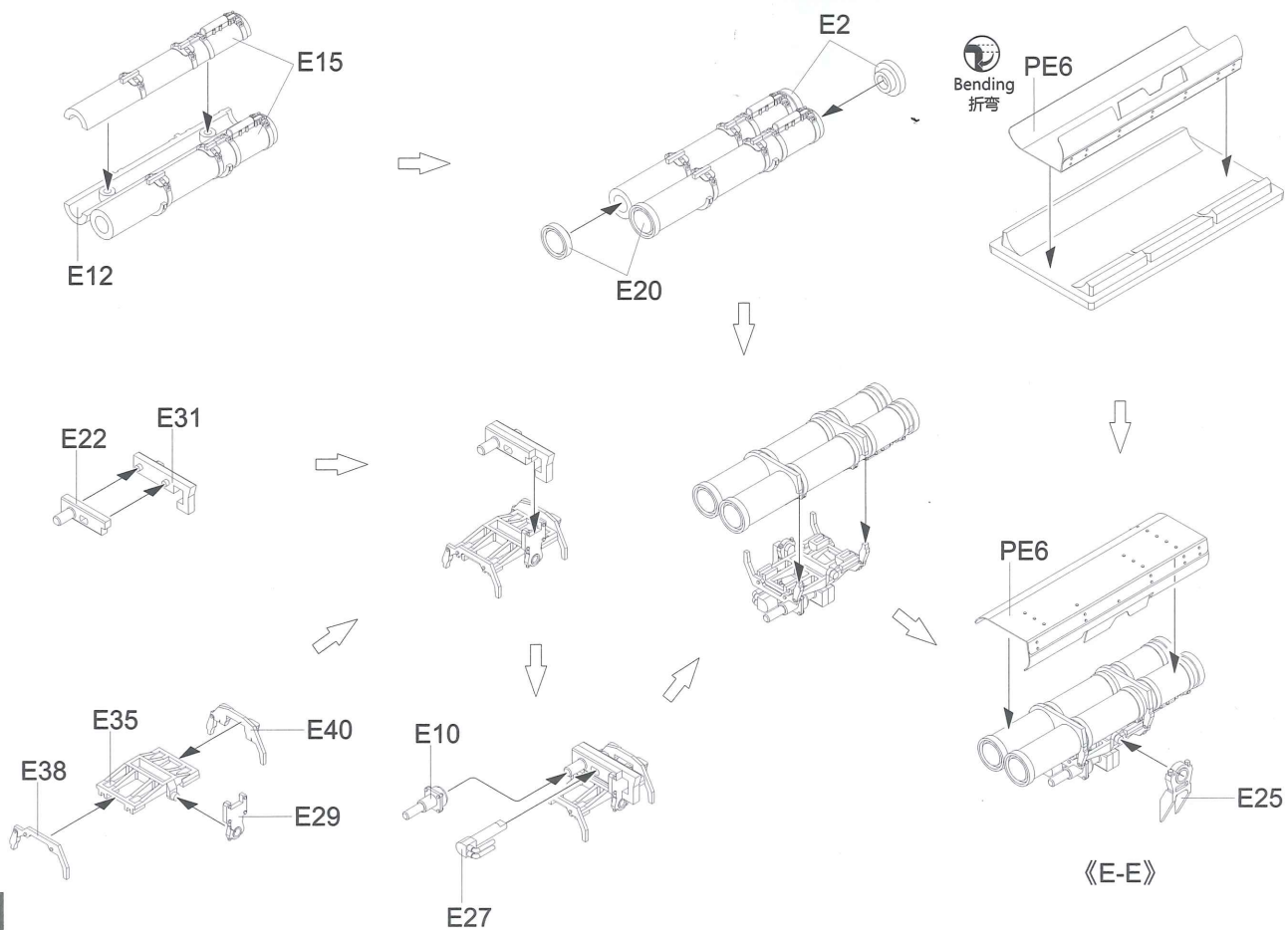
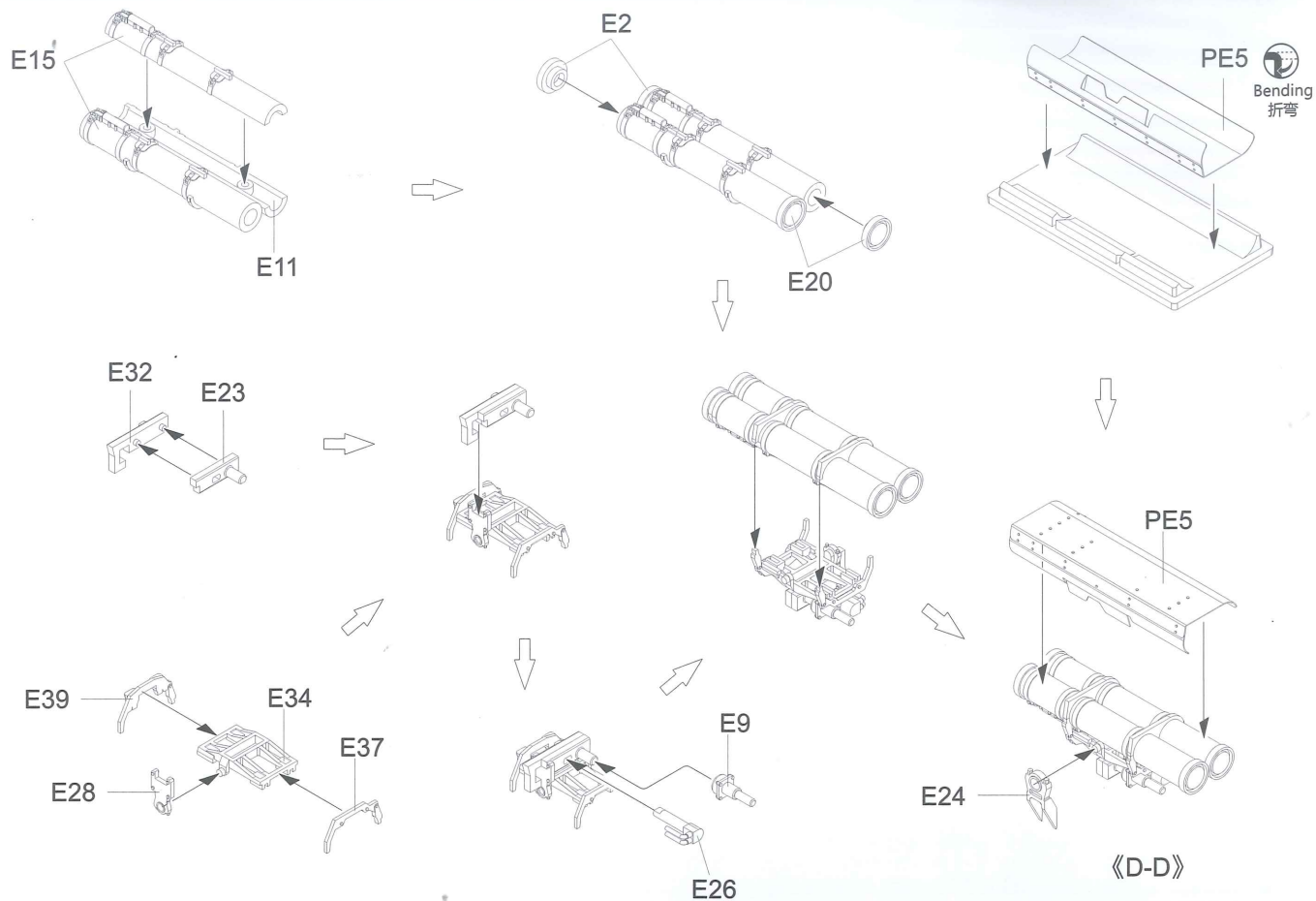

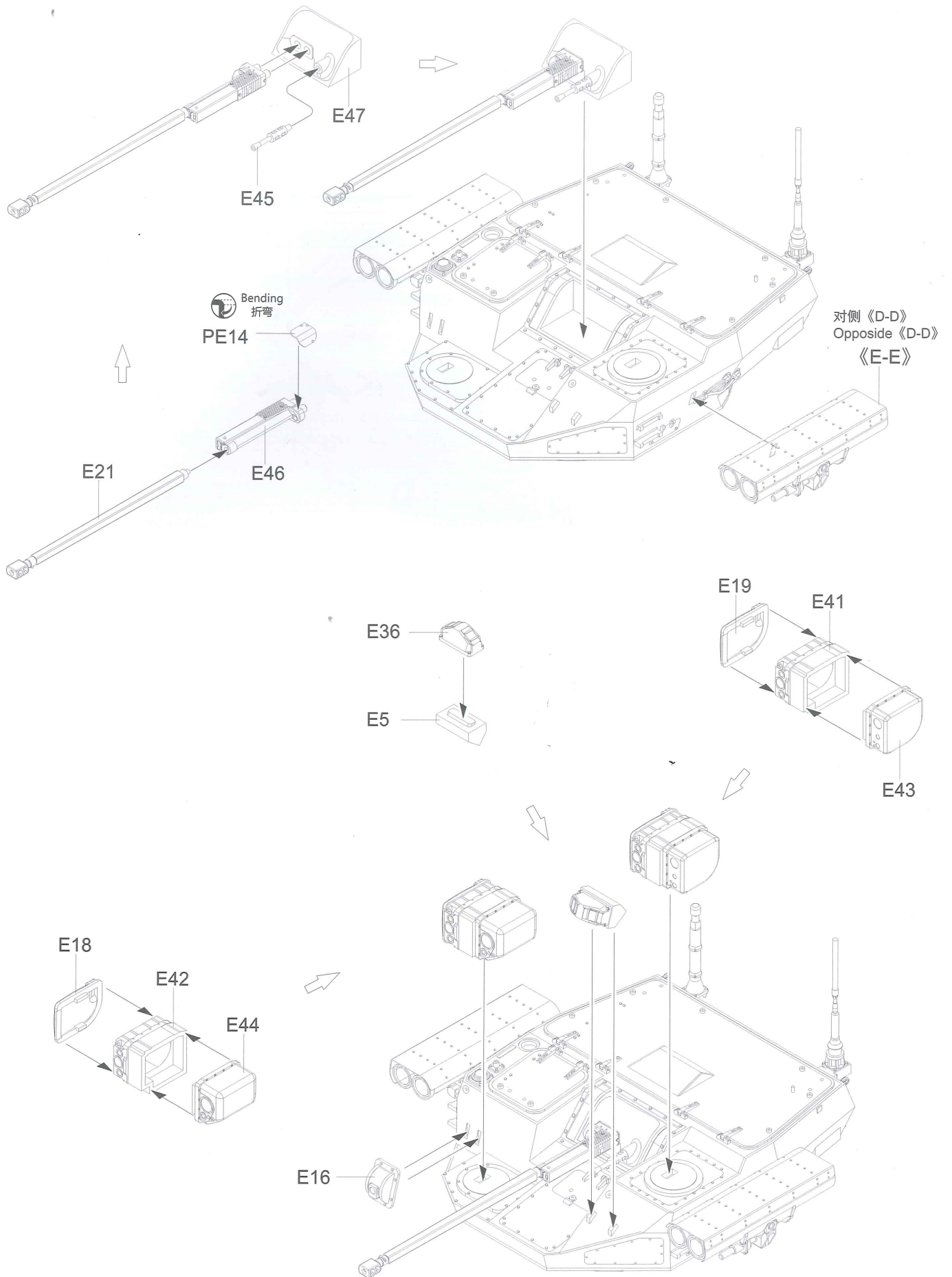

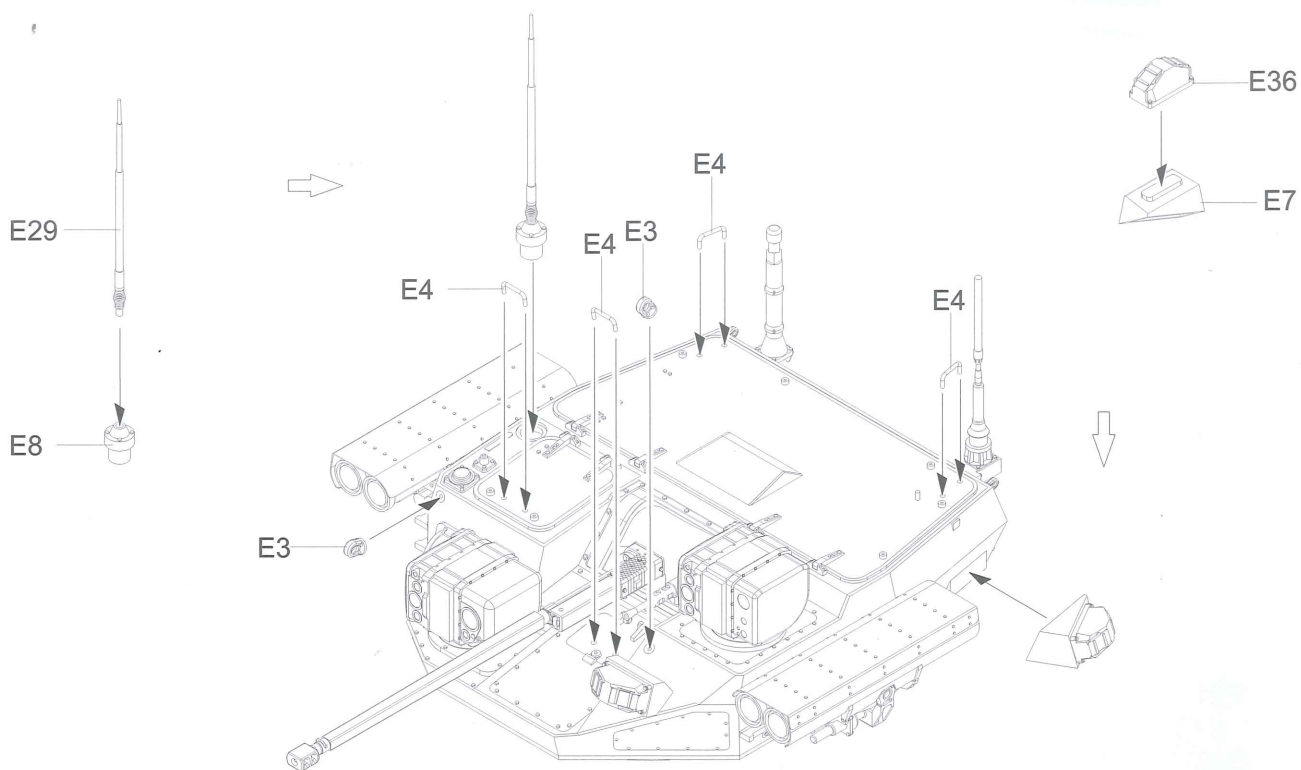

 Bending
折弯

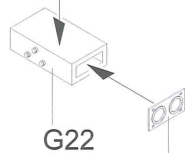
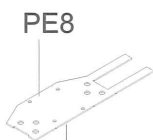

PE18

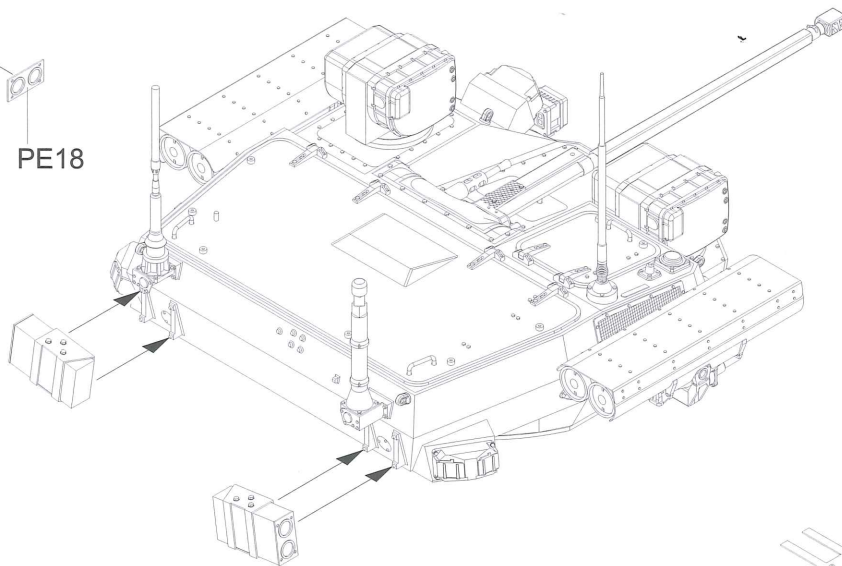

 Bending
折弯

PE7

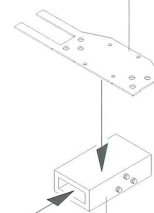

G22

PE18

ASSEMBLY
模型组装

21

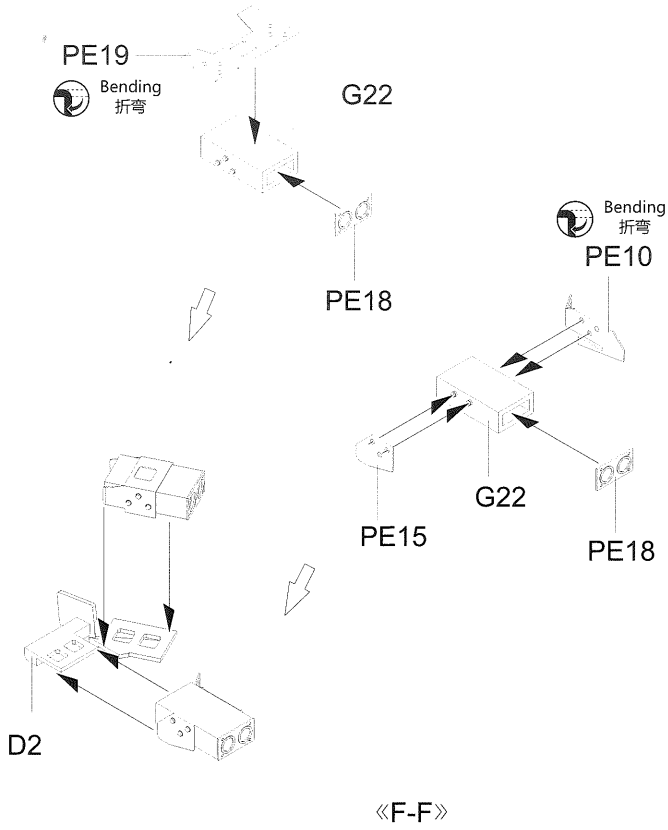

ASSEMBLY
模型组装

22

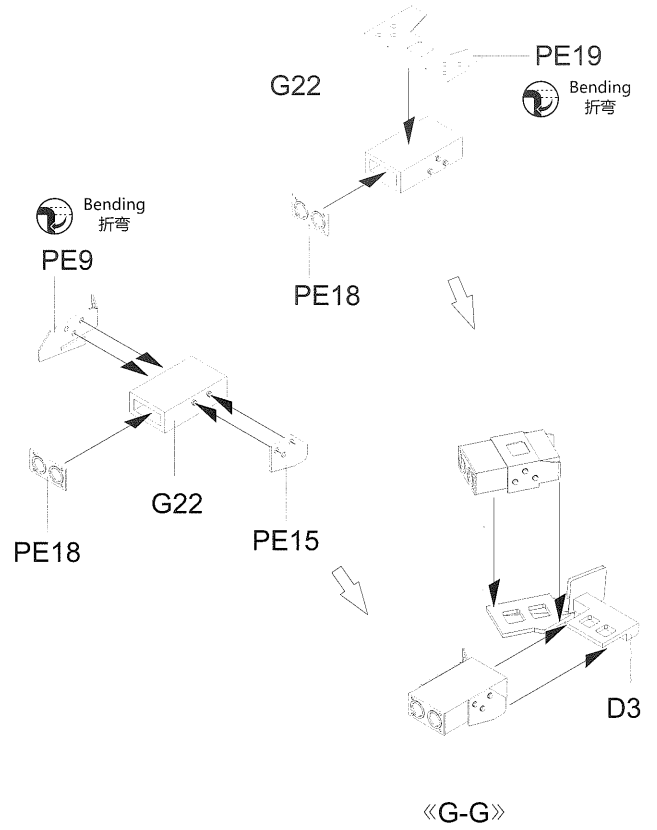

ASSEMBLY
模型组装

23

