

**MONOGRAM**

KIT 5309

85530900200

# F-16C FIGHTING FALCON

The F-16 Fighting Falcon was originally designed to be a lightweight fighter aircraft that would serve alongside the larger and more expensive F-15 Eagle in the U.S. Air force. From the beginning, the F-16 was a true fighter-bomber, capable of both air-to-air and air-to-ground missions in clear weather. But over the years, the capabilities of the Fighting Falcon have been expanded to allow it to perform a wide variety of missions in all kinds of weather and at night. The newest production blocks of F-16Cs are highly capable multi-mission aircraft that can deliver the newest precision guided weapons in the inventory. An F-16C can be armed with laser guided bombs to take out point targets in the center of a densely populated area in the morning, then be rearmed with HARM anti-radiation missiles to attack enemy radar that afternoon. The same plane can then be armed with Sidewinder and AMRAAM air-to-air missiles to counter hostile aircraft. Today, F-16s are in service with numerous air forces around the world, and the production line remains open as more Fighting Falcons with increased capabilities are delivered.

Your Monogram model of an F-16C comes with a choice of external stores, and three different markings are provided on the silk screen decal sheet. One of these is from the 79th Fighter Squadron of the 20th Fighter Wing which is based at Shaw Air Force Base. Another set of markings were used in a competition called "Tiger Meet of the Americas," held in 2001 at Buckley Air Force Base, Maryland, just outside Washington D.C. The third set of markings depicts a Fighting Falcon from the 170th Fighter Squadron of the 183rd Fighter Group. This unit is part of the Illinois Air National Guard, and it is based in Springfield, Illinois. Since September 11th, 2001, F-16Cs from the Air National Guard have patrolled the skies over America to guard against aircraft flown by terrorists that could pose a threat to various assets and facilities in the United States.



\* REPEAT SEVERAL TIMES  
\* A REPETER PLUSIEURS FOIS



\* OPTIONAL PARTS  
\* PIECES EN OPTION



\* DECAL  
\* DECAL COMANIE



\* ALTERNATIVE ASSEMBLY  
\* ENSEMBLAGE ALTERNATIVE



\* CEMENT TOGETHER  
\* A COLLER



\* REMOVE AND THROW AWAY  
\* A RETIRER ET JETER



\* DO NOT CEMENT  
\* NE PAS COLLER

## READ THIS BEFORE YOU BEGIN

- \* Study the assembly drawings.
- \* Each plastic part is identified by a number.
- \* In the assembly drawings, some parts will be marked by a star (★) to indicate chrome plated plastic.
- \* For better paint and decal adhesion, wash the plastic parts in a mild detergent solution. Rinse and let air dry.
- \* Check the fit of each piece before cementing in place.
- \* Use only cement for polystyrene plastic.
- \* Scrape plating and paint from areas to be cemented.
- \* Allow paint to dry thoroughly before handling parts.
- \* Any unused parts may be discarded.

## DECAL APPLICATION INSTRUCTIONS

1. Cut desired decal from sheet.
2. Dip decal in water for a few seconds.
3. Place wet decal on paper towel.
4. Wait until decal is movable on paper backing.
5. Place decal in position on model, face up and slide backing away.
6. Press out air bubbles with a soft damp cloth.
7. Milkiness that may appear is for better decal adhesion and will dry clear. Wipe away any excess adhesive.
8. Do not touch decal until fully dry.
9. Allow the decals 48 hours to dry before applying clear coat.

**NOTE:** Decals are compatible with setting solutions or solvents.

## LIRE CE QUI SUIT AVANT DE COMMENCER

- \* Etudier les schémas de montage.
- \* Chaque pièce en plastique est identifiée par un numéro.
- \* Sur les schémas de montage, certaines pièces sont marquées d'une étoile (★) pour indiquer qu'elles sont en plastique chromé.
- \* Pour une meilleure prise de la peinture et des autocollants, laver les pièces en plastique avec une solution détergente peu concentrée. Les rincer et les laisser sécher à l'air.
- \* Vérifier que chaque pièce s'ajuste bien avant de la coller en place.
- \* N'utiliser que de la colle pour polystyrène.
- \* Gratter les parties à coller pour enlever le chrome et la peinture.
- \* Laisser la peinture bien sécher avant de manipuler les pièces.
- \* Toute pièce inutilisée peut être jetée.

## DIRECTIVES D'APPLICATION DES AUTOCOLLANTS

1. Découper l'autocollant désiré de la feuille.
2. Tremper l'autocollant dans de l'eau pendant quelques secondes.
3. Placer l'autocollant mouillé sur une serviette en papier.
4. Attendez que l'autocollant puisse être déplacé sur son support en papier.
5. Mettre l'autocollant en position sur le modèle face sur le dessus et faire glisser le support pour l'enlever.
6. Appuyer avec un chiffon doux humide pour éliminer les bulles d'air.
7. La substance laiteuse qui peut apparaître est destinée à améliorer l'adhésion de l'autocollant et devient incolore au séchage. Essuyer pour enlever tout excédent d'adhésif.
8. Ne pas toucher l'autocollant tant qu'il n'est pas bien sec.
9. Laisser l'autocollant sécher pendant 48 heures avant d'appliquer une couche transparente.

**REMARQUE:** Les autocollants sont compatibles avec les solutions de fixation ou les solvants.

**This optional paint guide is provided if you choose to detail paint your model.**

*Ce guide de peinture vous sera fourni si vous choisissez de peindre votre modèle en détail.*

Bright Silver	Argent clair
Dark Gull Gray FS 36231	Gris cendré foncé
Flat Black	Noir mat
Flat White	Blanc mat
Gloss White	Blanc lustré
Gunship Gray FS 36118	Gris hélicoptère
Jet Exhaust	Flux d'éjection
Light Ghost Gray FS 36375	Gris fantôme clair
Light Sea Gray FS 36270	Gris de mer clair
Medium Green FS 34227	Vert moyen
Olive Drab FS 34424	Olivet
Satin Black	Noir satiné
Steel	Acier
Transparent Red	Rouge transparent
Transparent Green	Vert transparent

If you have any questions or comments, call our hotline at: **(800) 833-3570**  
or, please write to:

Revell-Monogram Consumer Service Department, 8601 Waukegan Road, Morton Grove, Illinois 60053  
Be sure to include the plan number (85530900200), part number, description, your return address and phone number.

Visit our website: [www.revell-monogram.com](http://www.revell-monogram.com)

# 1 COCKPIT AND INTAKE ASSEMBLY

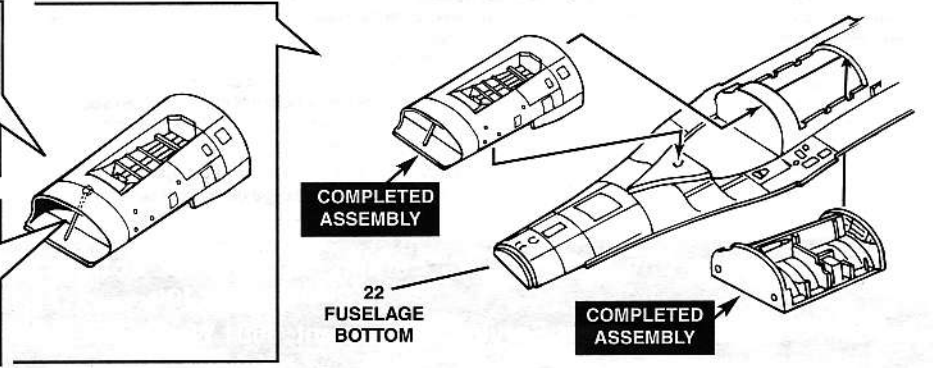
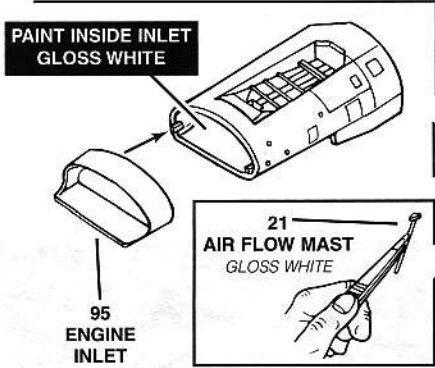
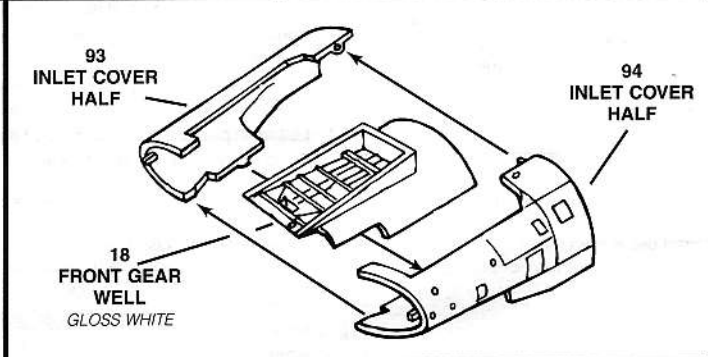
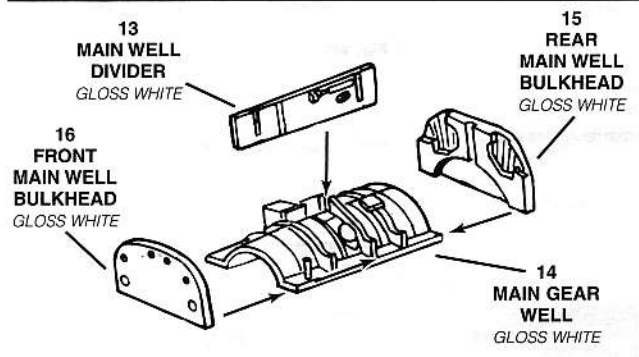
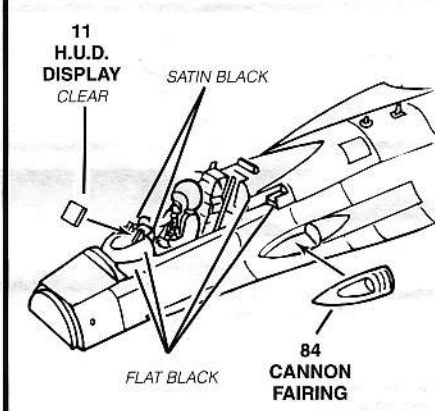
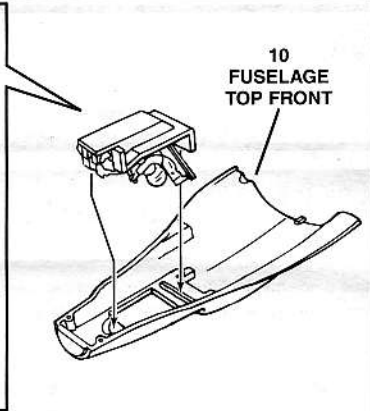
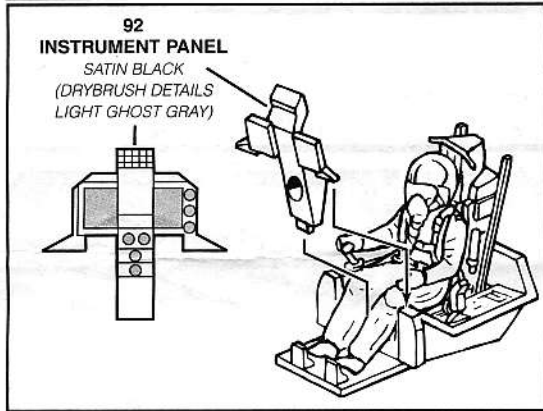
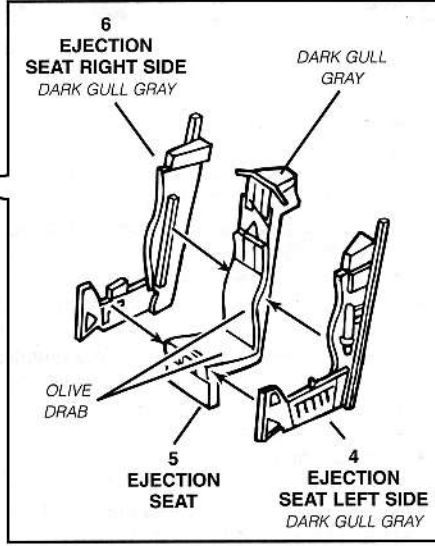
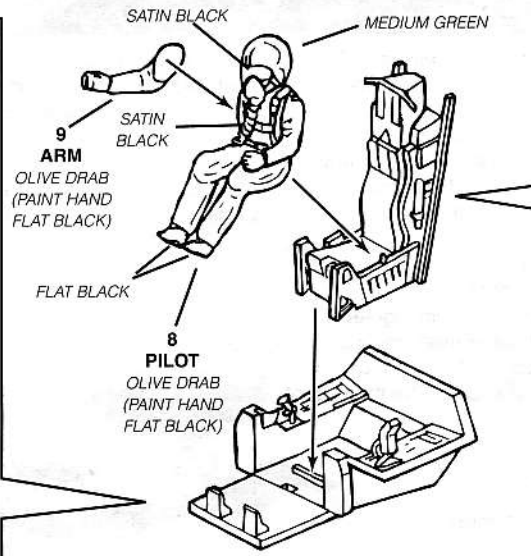
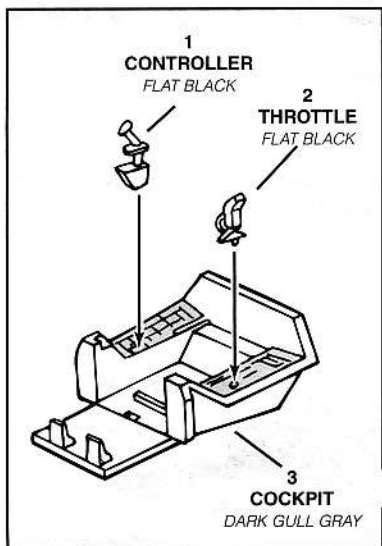

# FUSELAGE ASSEMBLY

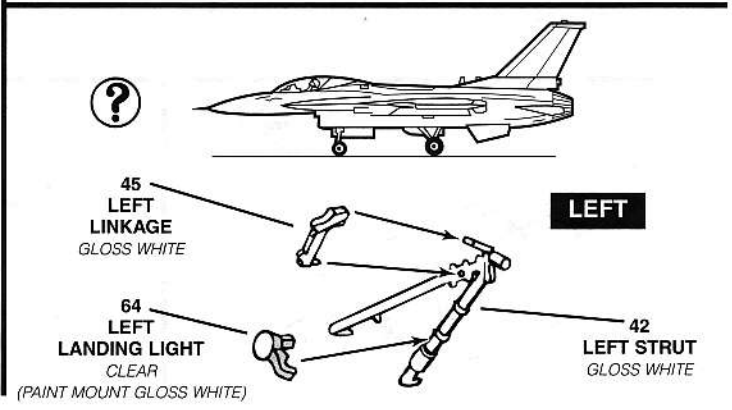
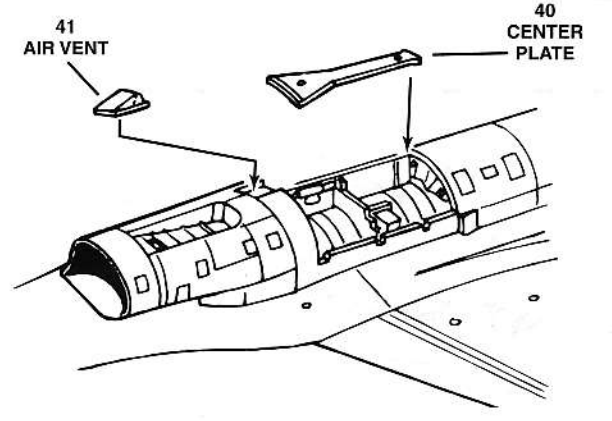
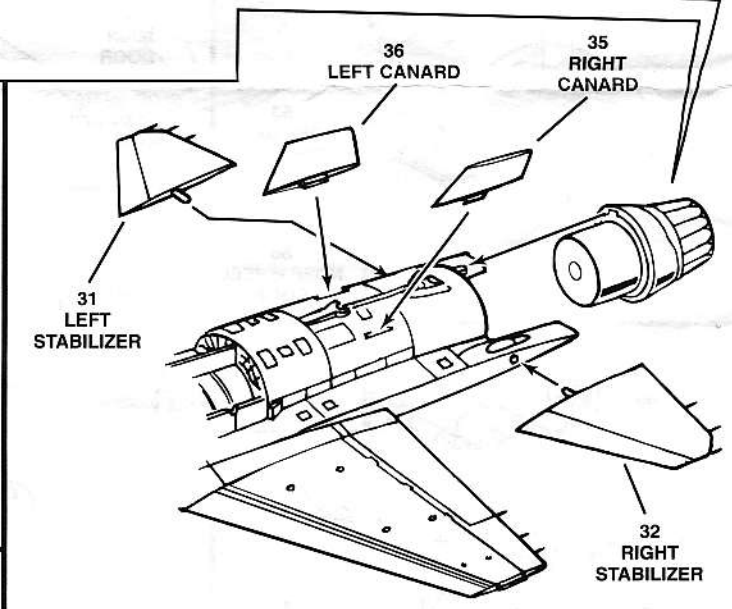
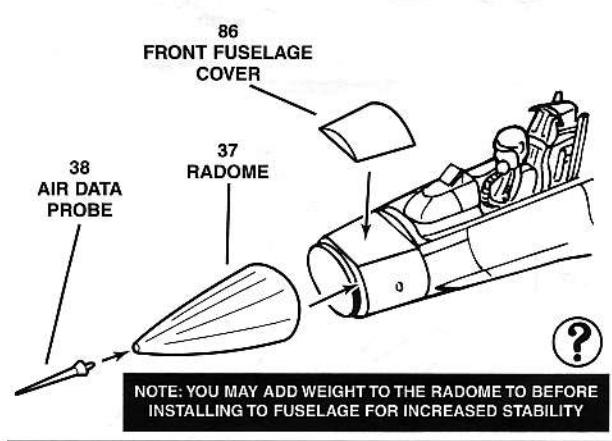
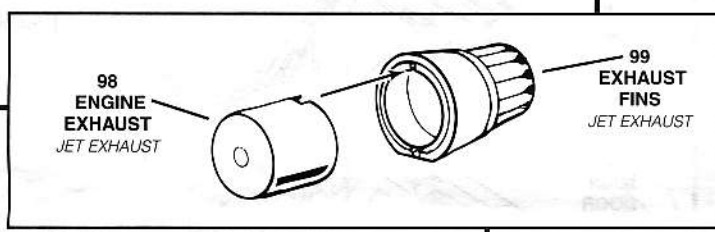
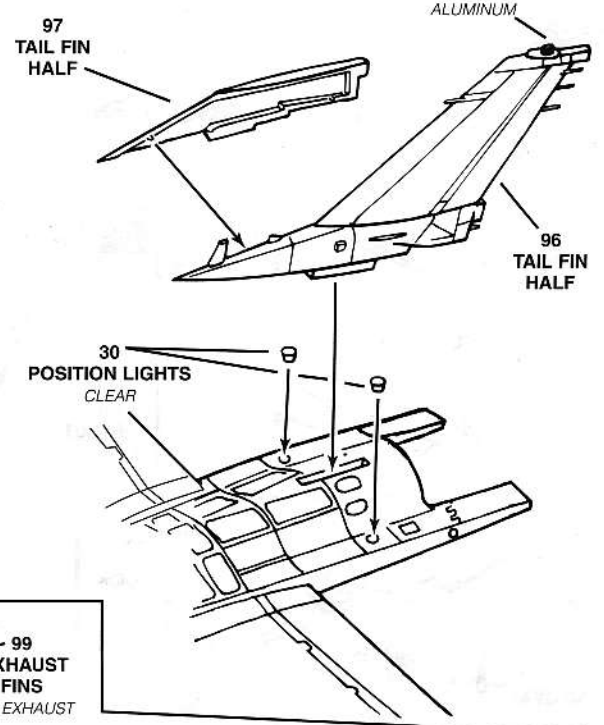
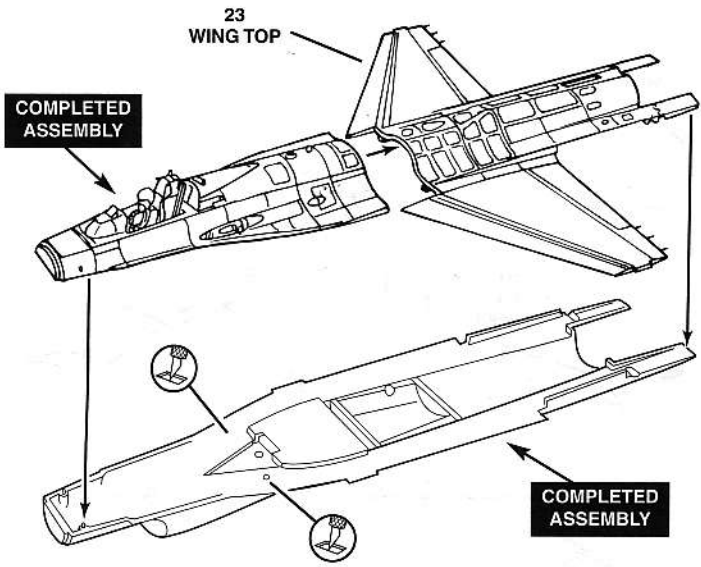

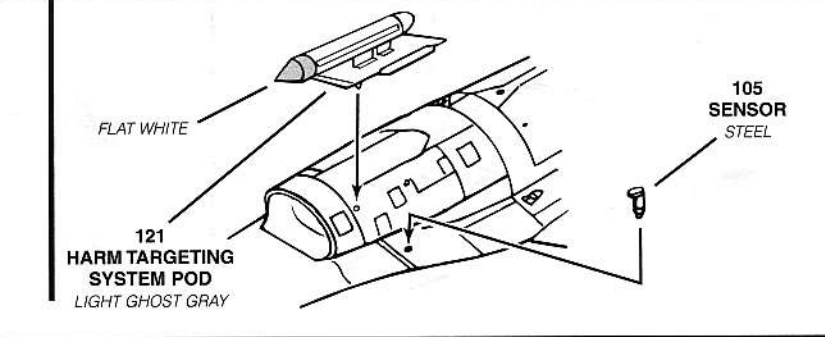
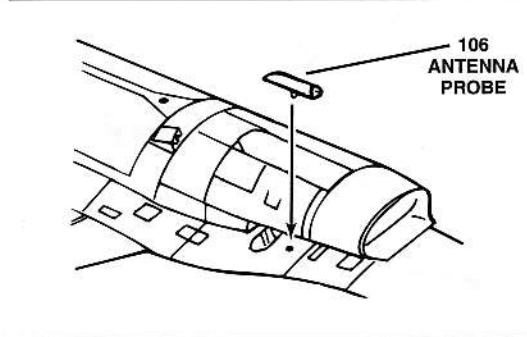
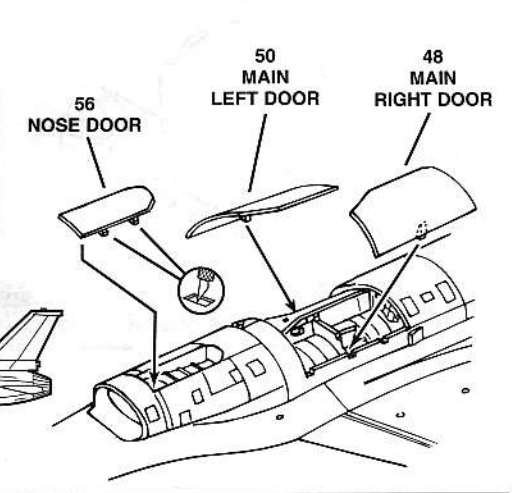
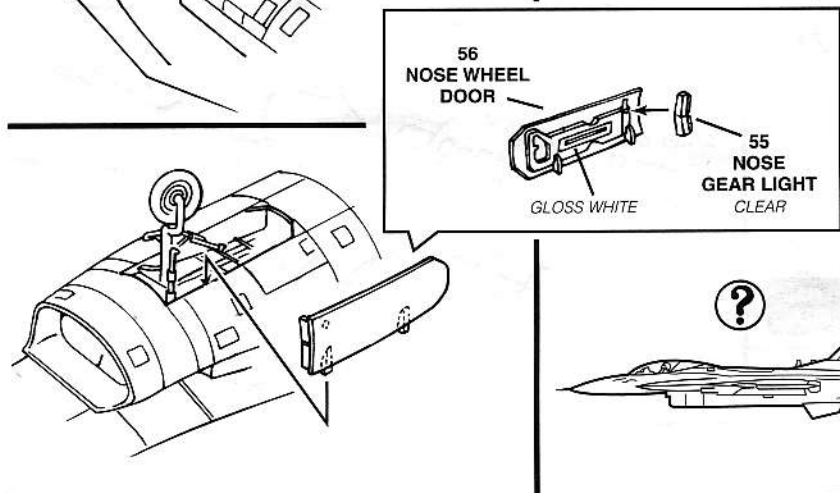
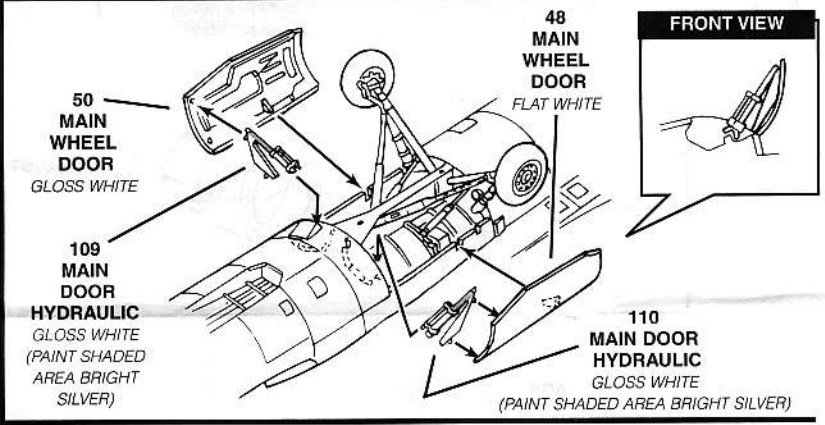
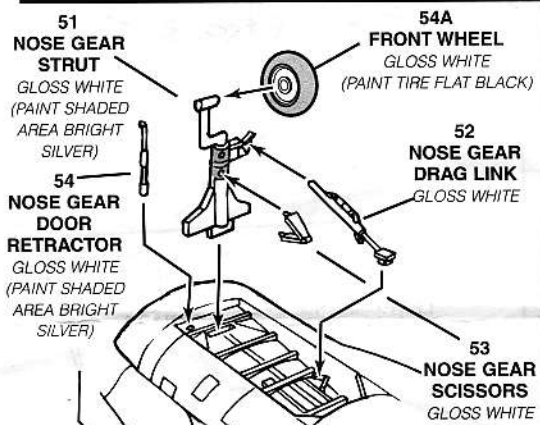
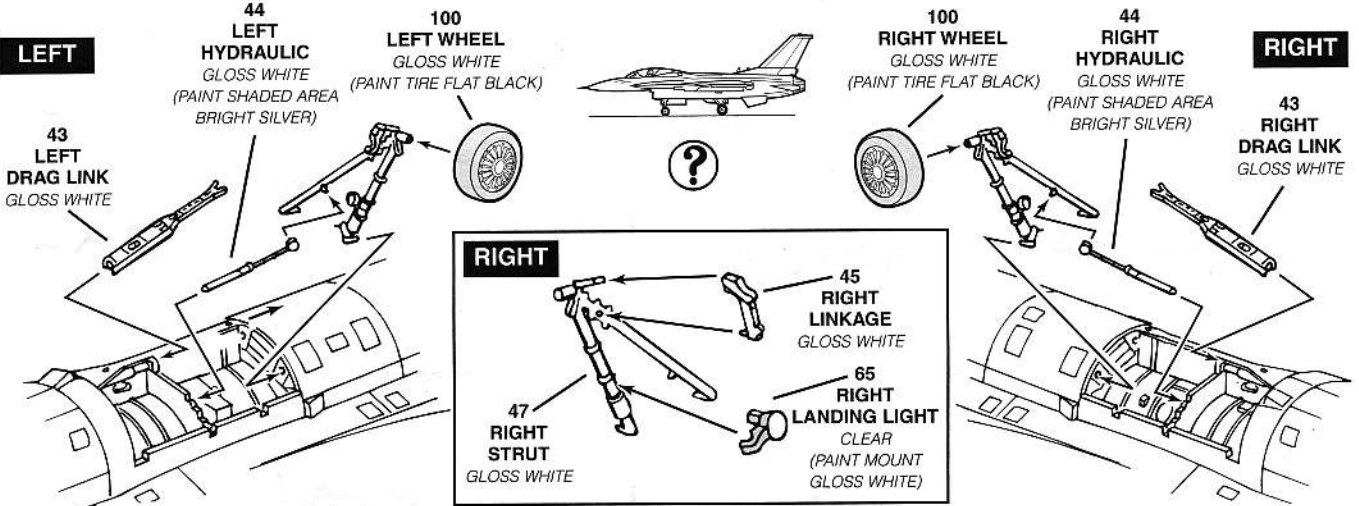

# FINAL ASSEMBLY

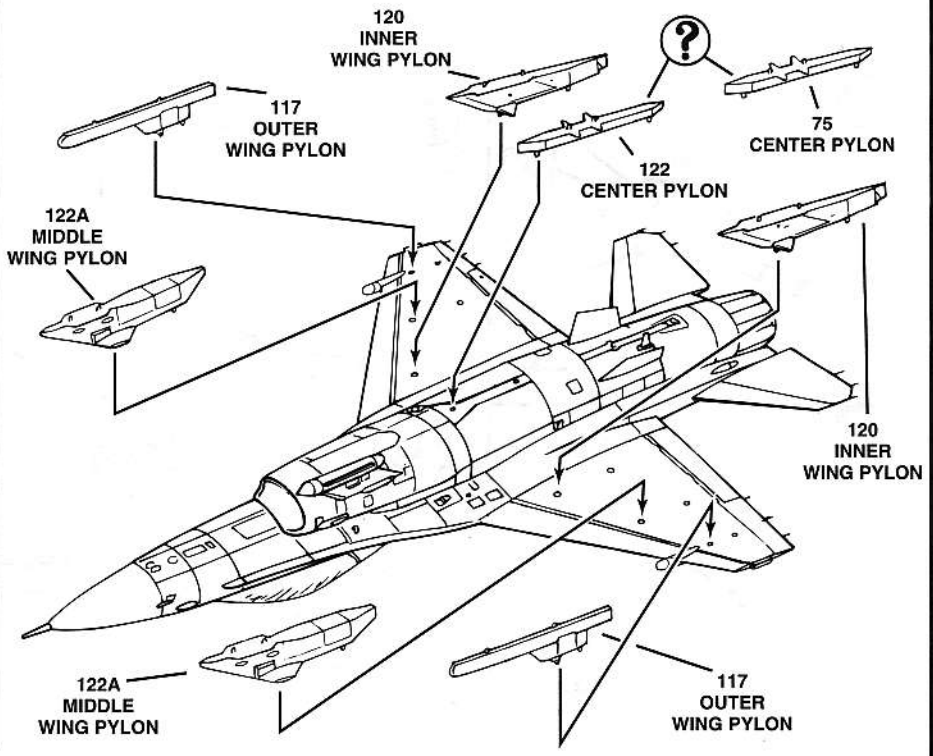
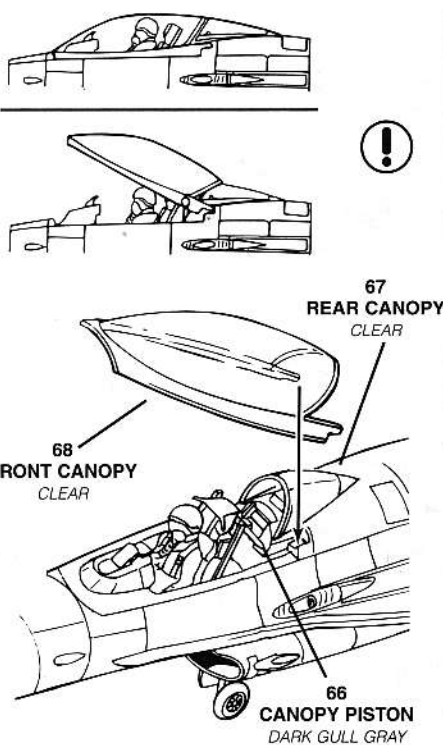
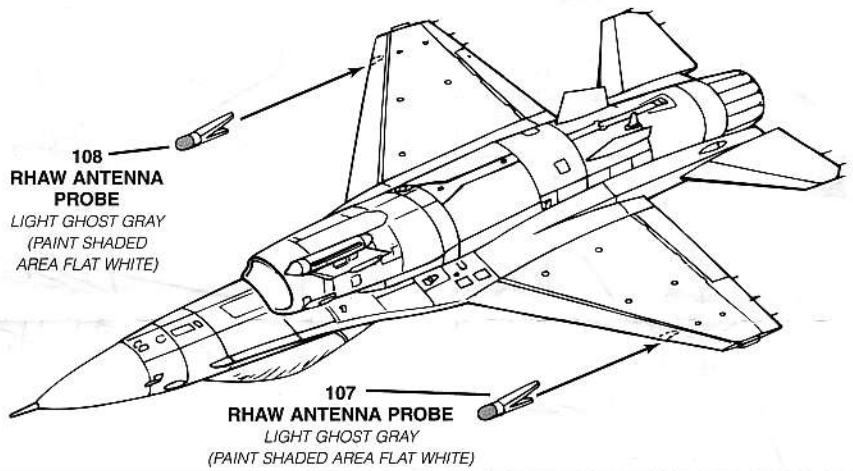
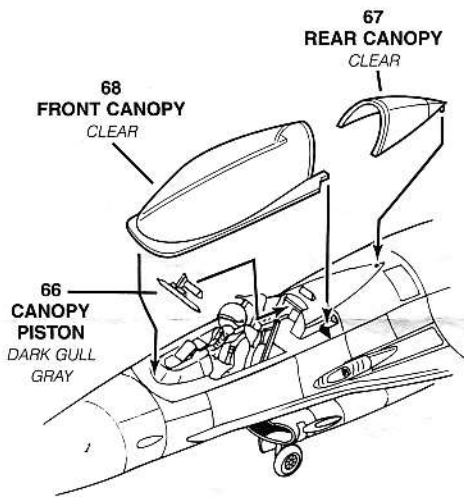
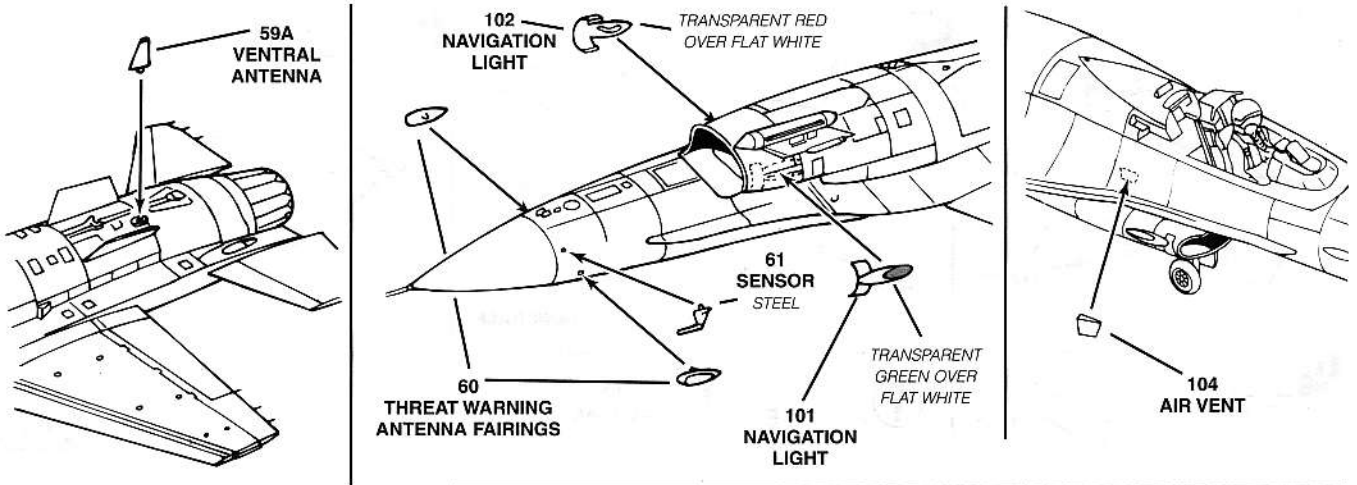

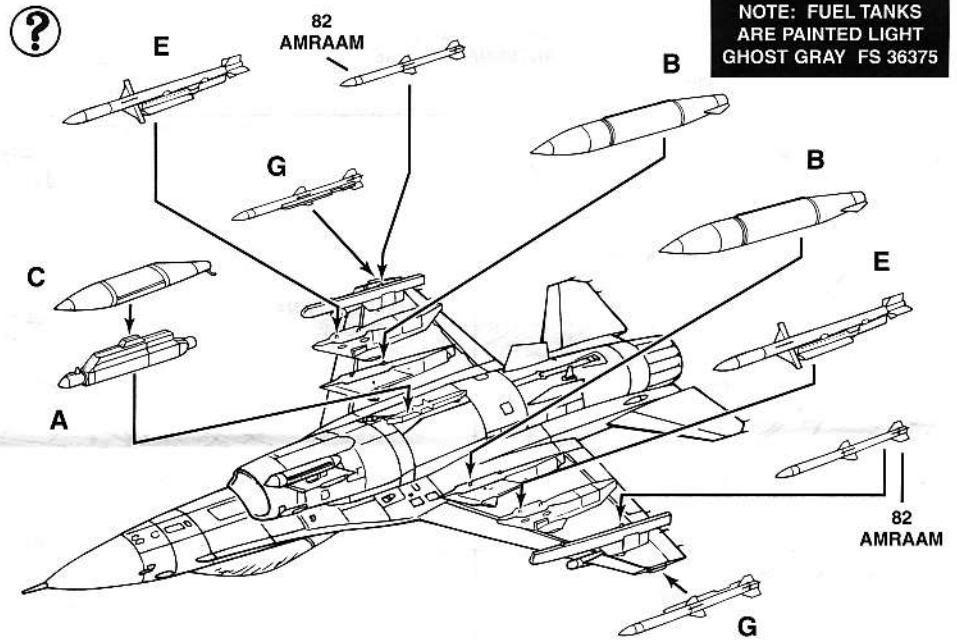
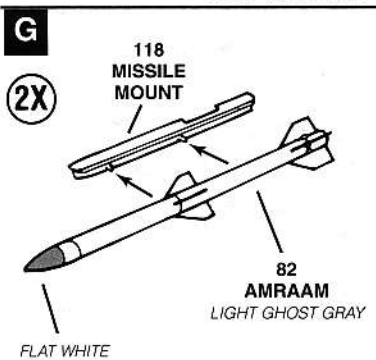
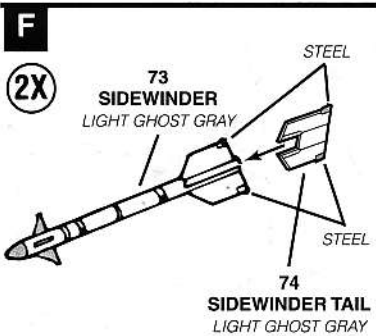
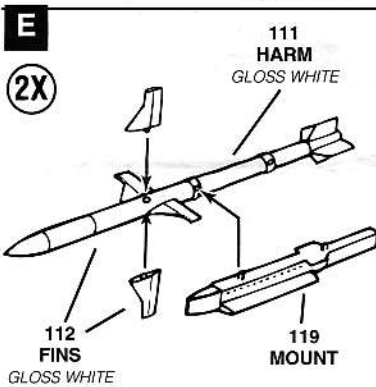
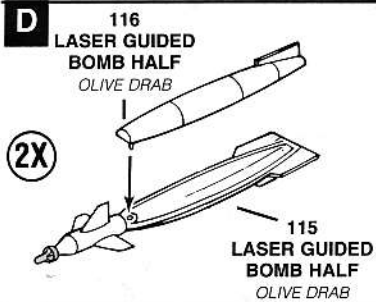
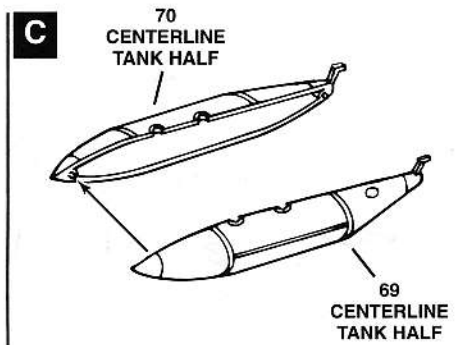
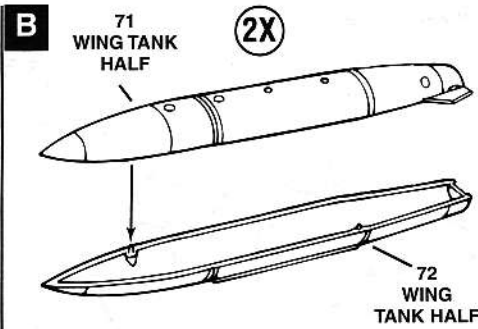
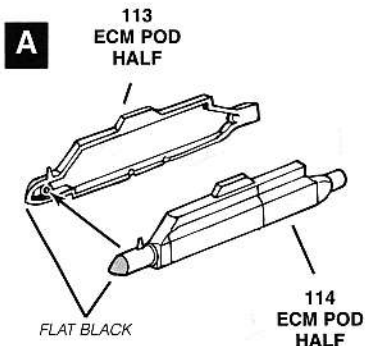

NOTE: FUEL TANKS ARE PAINTED LIGHT GHOST GRAY FS 36375

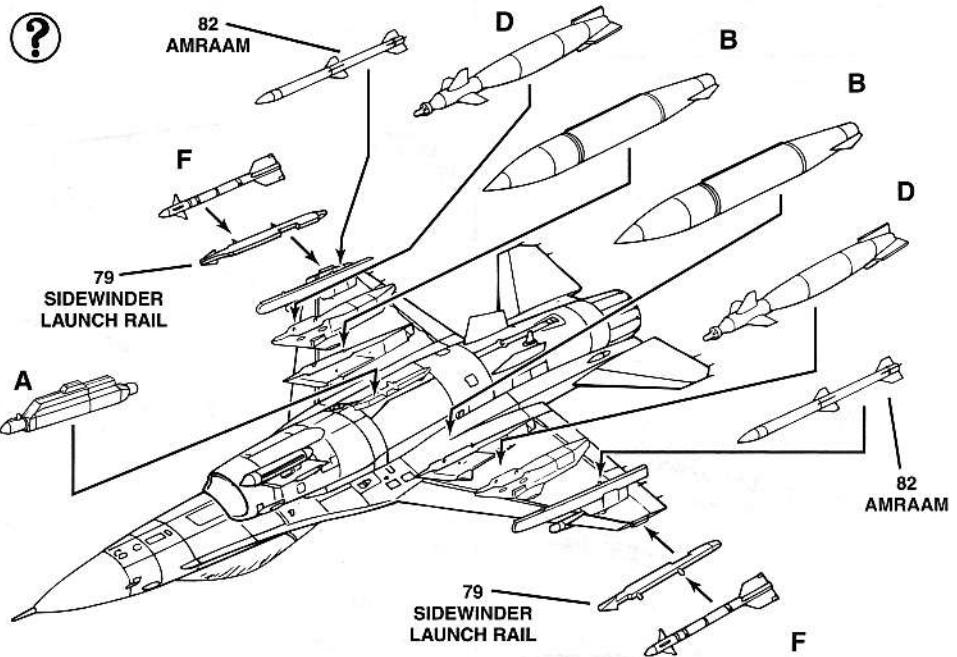

## PAINT COLORS

- A**  GUNSHIP GRAY  
FS 36118
- B**  LIGHT GHOST GRAY  
FS 36375
- C**  LIGHT SEA GRAY  
FS 36270
- D**  JET EXHAUST
- E**  MEDIUM GREEN  
FS 34227
- F**  WHITE
- G**  BLACK

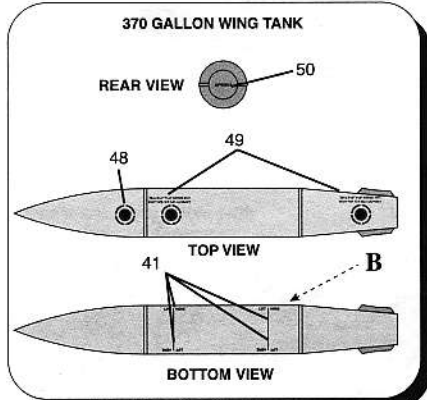
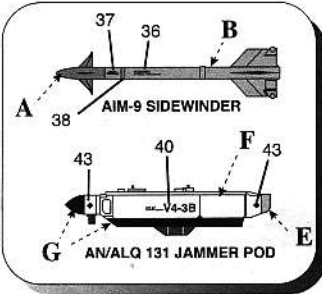
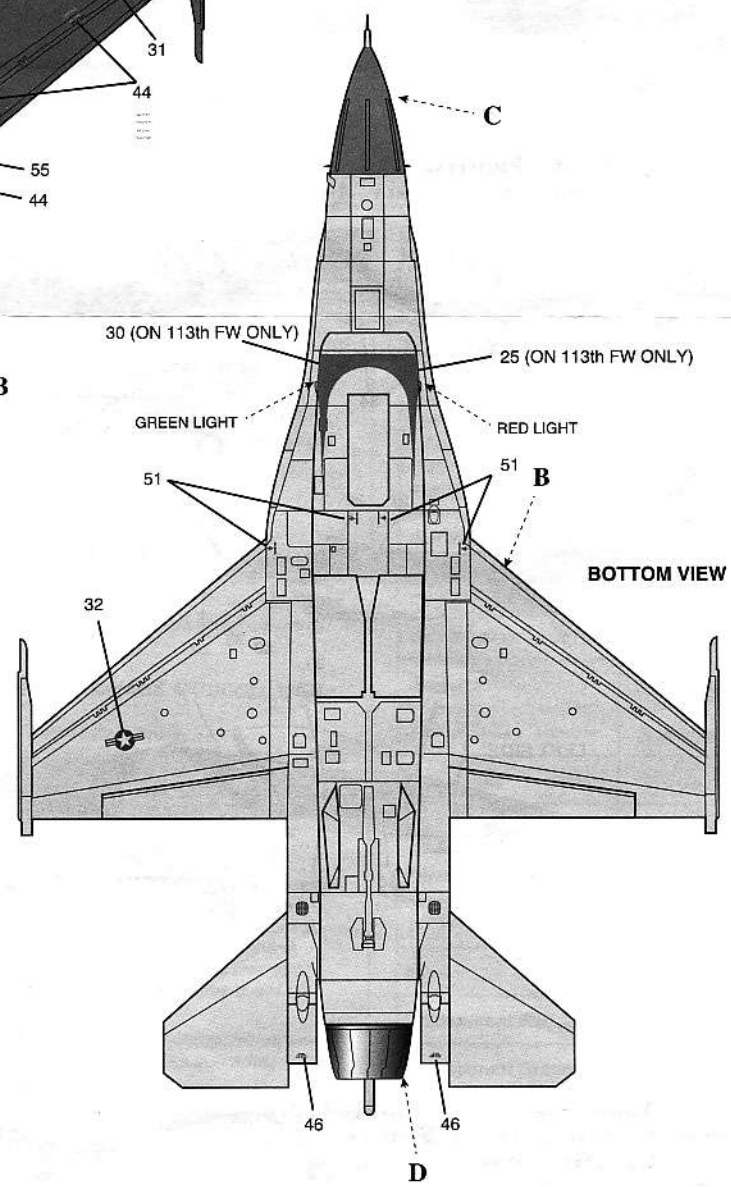
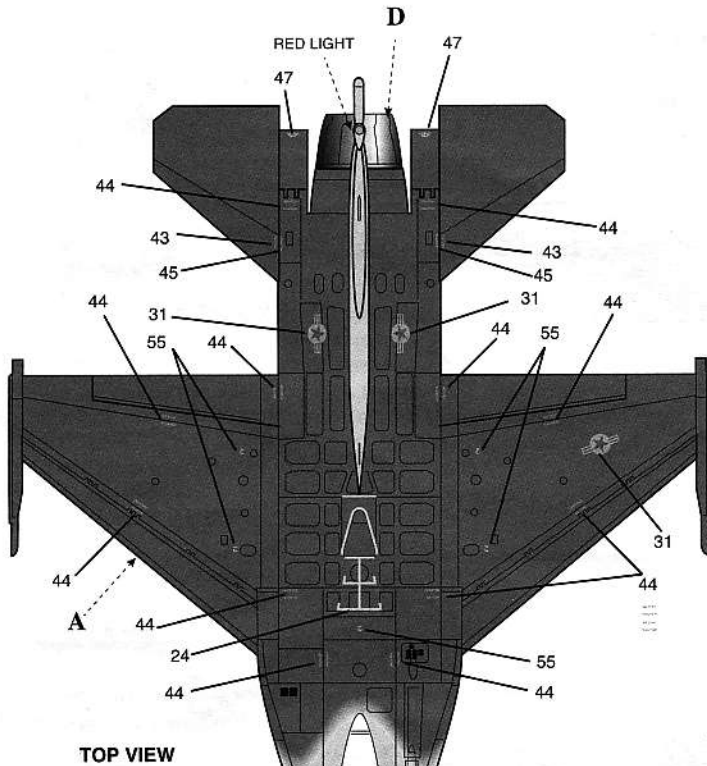

**F-16C FIGHTING FALCON, 91-0379, "TIGER MEET OF THE AMERICAS", 79TH FIGHTER SQUADRON, 20TH FIGHTER WING, SHAW AIR FORCE BASE, SOUTH CAROLINA**

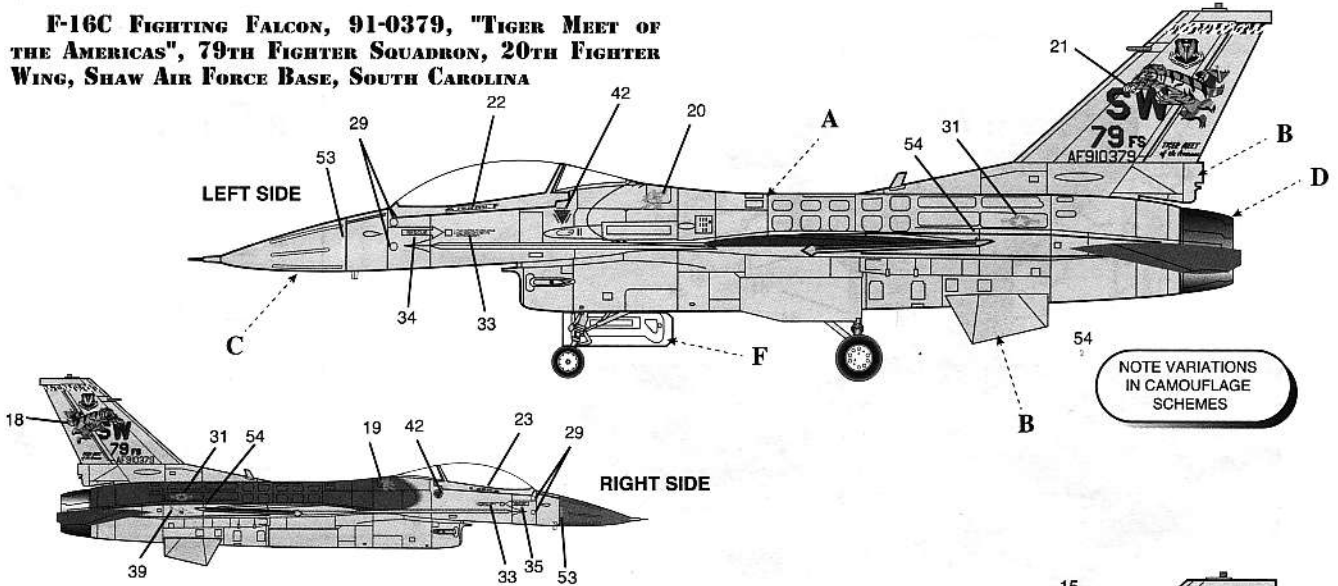

**F-16C FIGHTING FALCON, 113TH FIGHTER WING, DISTRICT OF COLUMBIA AIR NATIONAL GUARD, 50TH ANNIVERSARY.**

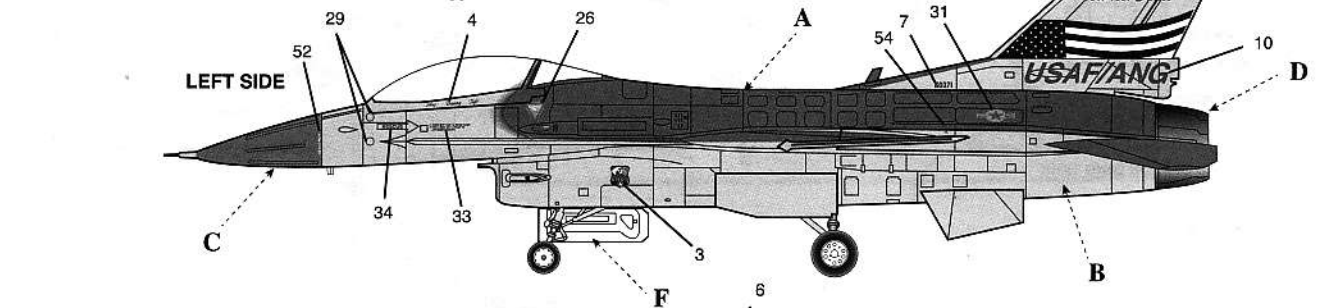
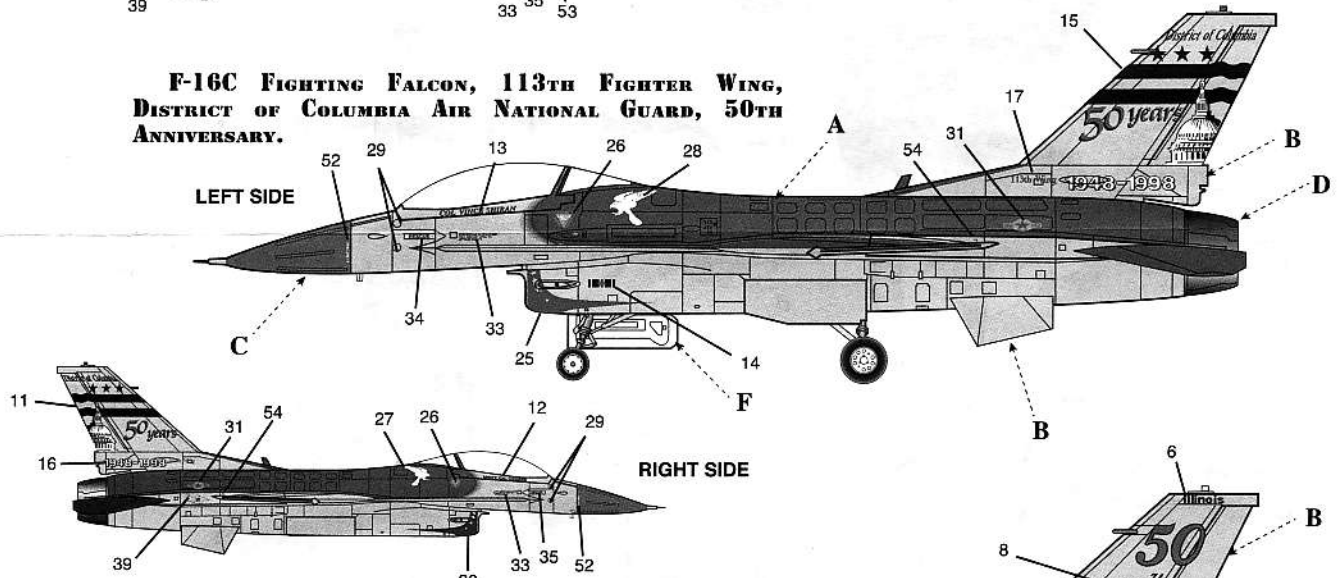

**F-16C FIGHTING FALCON, 86-0371, 170TH FIGHTER SQUADRON, 183RD FIGHTER WING, ILLINOIS AIR NATIONAL GUARD, SPRINGFIELD, ILLINOIS.**

