



KIT 2839

85283900200

2006 Mustang GT

At 40 plus years and counting, the Ford Mustang is showing no signs of middle-age aches and pains. In fact, you could say that this pony car has been reborn with a healthy dose of the same type of magic that made the original Mustang such a smash hit when it was introduced at the New York Worlds Fair in April, 1964. At the time, Ford was in need of some excitement in its line. Bolstered by a multi-million dollar ad blitz, the Mustang almost single-handedly changed the way Americans looked at their cars. It was the right product at the right time.

The same can be said about the all-new Mustang today. For the first time, the car is based off its own platform instead of being derived from another car in the Ford line like the Falcon or the Fairmont. Those two, which many of you may not even remember, were pleasant enough but didn't rate too high on the fun meter. If while looking at the new Mustang you're reminded of some of the now-legendary models from the mid and late 1960's, well, that's

exactly what the stylists intended. From the fastback profile to the triple lens tail lamps to the dual driving lamps in the grille opening, the new car recalls the great Mustangs of the past. Yet, the engineers have built in all the lessons learned over the past four decades. The body structure is much stiffer providing a smoother, more stable ride and even better cornering ability than before. From top to bottom, it's hard to find an area where the new Mustang hasn't vastly improved from its predecessors. A larger, more comfortable interior. Standard air conditioning, power windows and seats. 25 miles per gallon on the highway. All very practical. Is that why you buy a Mustang GT? Heck, no. Mash the throttle and go from 0 to 60 mph in 5.2 seconds. Turn off the traction control and leave two long patches of steel belted radial on the pavement. Or just sit in the drivers seat and let the engine idle. Listen to the rumble from the exhaust and smile. That's what we're talking about.



* REPEAT SEVERAL TIMES
* A REPETER PLUSIEURS FOIS



* OPTIONAL PARTS
* PIECES EN OPTION



* DECAL
* DECAL COMANIE



* ALTERNATIVE ASSEMBLY
* ENSEMBLAGE ALTERNATIVE



* CEMENT TOGETHER
* A COLLER



* REMOVE AND THROW AWAY
* A RETIRER ET JETER



* DO NOT CEMENT
* NE PAS COLLER

READ THIS BEFORE YOU BEGIN

- Study the assembly drawings.
- Each plastic part is identified by a number.
- In the assembly drawings, some parts will be marked by a star (★) to indicate chrome plated plastic.
- For better paint and decal adhesion, wash the plastic parts in a mild detergent solution. Rinse and let air dry.
- Check the fit of each piece before cementing in place.
- Use only cement for polystyrene plastic.
- Scrape plating and paint from areas to be cemented.
- Allow paint to dry thoroughly before handling parts.
- Any unused parts may be discarded.

DECAL APPLICATION INSTRUCTIONS

1. Cut desired decal from sheet.
2. Dip decal in water for a few seconds.
3. Place wet decal on paper towel.
4. Wait until decal is movable on paper backing.
5. Place decal in position on model, face up and slide backing away.
6. Press out air bubbles with a soft damp cloth.
7. Milkiness that may appear is for better decal adhesion and will dry clear. Wipe away any excess adhesive.
8. Do not touch decal until fully dry.
9. Allow the decals 48 hours to dry before applying clear coat.

NOTE: Decals are compatible with setting solutions or solvents.

LIRE CE QUI SUIV AVANT DE COMMENCER

- Etudier les schémas de montage.
- Chaque pièce en plastique est identifiée par un numéro.
- Sur les schémas de montage, certaines pièces sont marquées d'une étoile (★) pour indiquer qu'elles sont en plastique chromé.
- Pour une meilleure prise de la peinture et des autocollants, laver les pièces en plastique avec une solution détergente peu concentrée. Les rincer et les laisser sécher à l'air.
- Vérifier que chaque pièce s'ajuste bien avant de la coller en place.
- N'utiliser que de la colle pour polystyrène.
- Gratter les parties à coller pour enlever le chrome et la peinture.
- Laisser la peinture bien sécher avant de manipuler les pièces.
- Toute pièce inutilisée peut être jetée.

DIRECTIVES D'APPLICATION DES AUTOCOLLANTS

1. Découper l'autocollant désiré de la feuille.
2. Tremper l'autocollant dans de l'eau pendant quelques secondes.
3. Placer l'autocollant mouillé sur une serviette en papier.
4. Attendez que l'autocollant puisse être déplacé sur son support en papier.
5. Mettre l'autocollant en position sur le modèle face sur le dessus et faire glisser le support pour l'enlever.
6. Appuyer avec un chiffon doux humide pour éliminer les bulles d'air.
7. La substance laiteuse qui peut apparaître est destinée à améliorer l'adhésion de l'autocollant et devient incolore au séchage. Essuyer pour enlever tout excédent d'adhésif.
8. Ne pas toucher l'autocollant tant qu'il n'est pas bien sec.
9. Laisser l'autocollant sécher pendant 48 heures avant d'appliquer une couche transparente.

REMARQUE: Les autocollants sont compatibles avec les solutions de fixation ou les solvants.

This paint guide is provided to complete this kit as shown on the box.

Ce guide de peinture est fourni pour reproduire le modèle réduit qui apparaît sur la boîte.

Satin Black	Noir satiné
Aluminum	Aluminium
Gloss Silver	Argent lustre
Gloss Blue	Bleu lustre
Gloss Red	Rouge lustre
Flat Dark Gray	Gris foncé mat
Clear Orange	Orange clair
Clear Red	Rouge clair
Gloss White	Blanc lustre

If you have any questions or comments, call our hotline at: **(800) 833-3570**
or, please write to:

Revell-Monogram Consumer Service Department, 725 Landwehr Road, Northbrook, Illinois 60062

Be sure to include the plan number (85283900200), part number, description, your return address and phone number.

Visit our website: www.revell.com

1

ENGINE ASSEMBLY

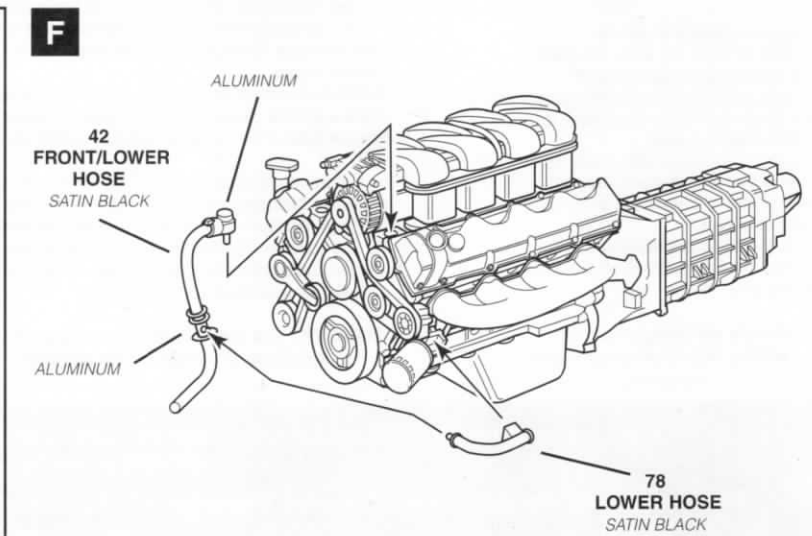
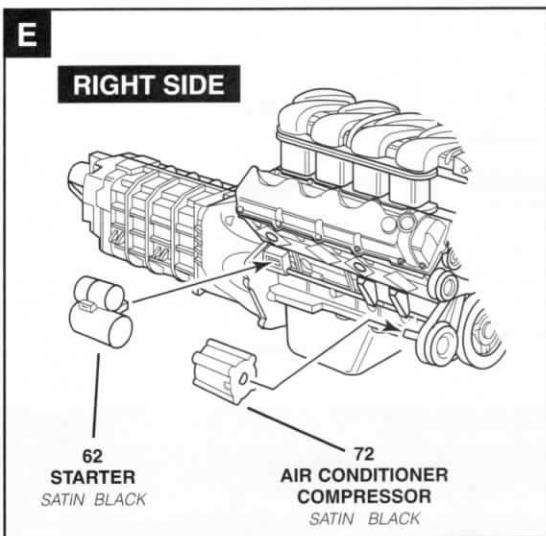
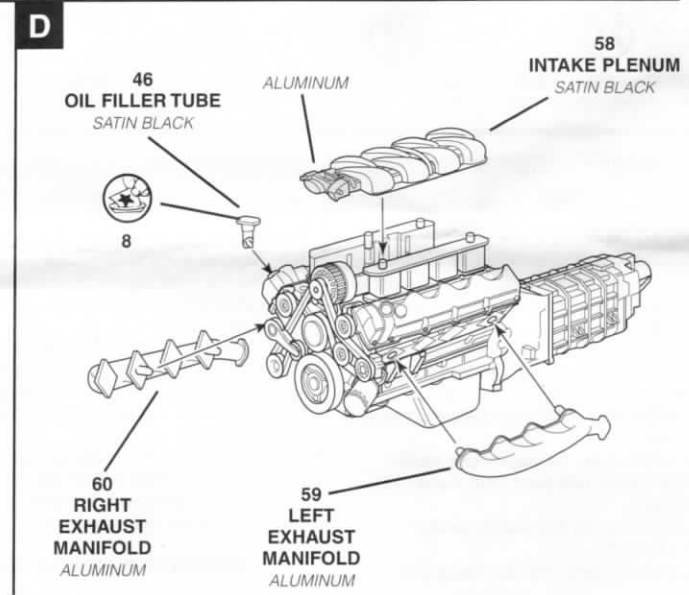
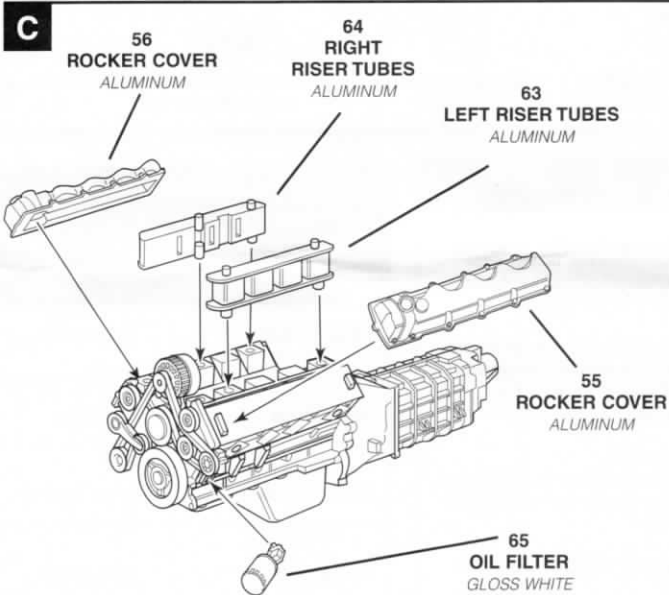
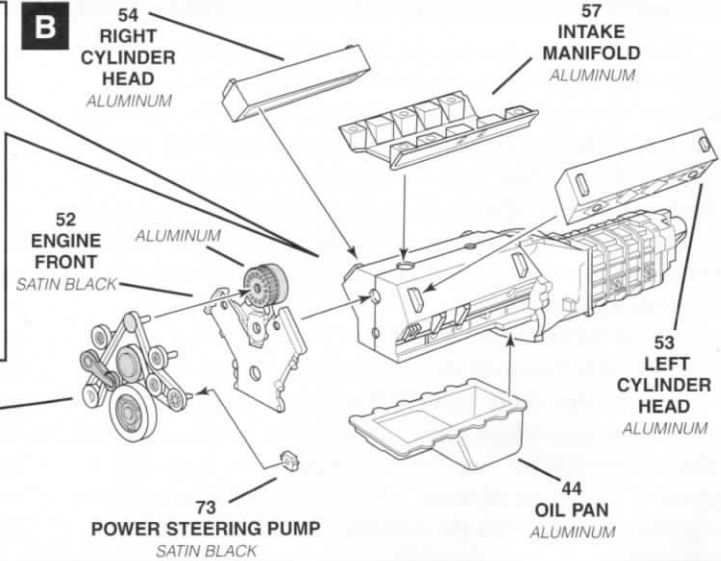
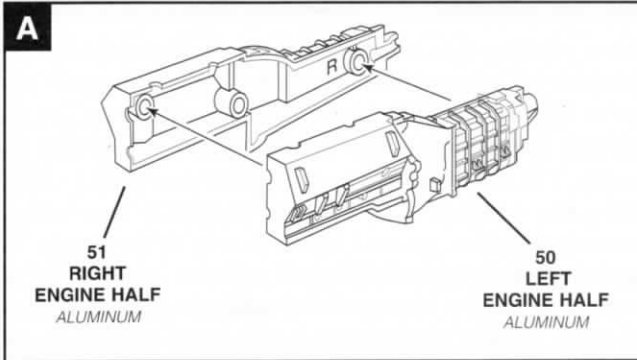

2

SWAY BAR / RADIATOR ASSEMBLY

FRONT

25 CHASSIS
GLOSS SILVER

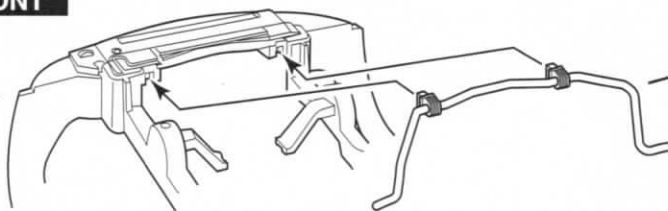

28 FRONT SWAY BAR
SATIN BLACK

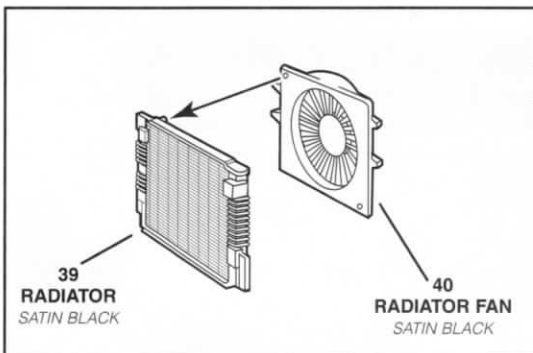

FRONT

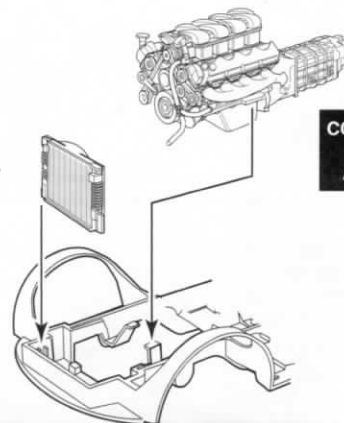

3

EXHAUST ASSEMBLY

70 EXHAUST
ALUMINUM

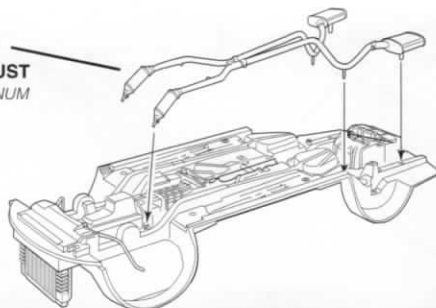

4

SUSPENSION ASSEMBLY

A

27 STEERING RACK
ALUMINUM

SATIN BLACK

29 LEFT FRONT STRUT
SATIN BLACK
(GLOSS BLUE SPRINGS)

30 RIGHT FRONT STRUT
SATIN BLACK
(GLOSS BLUE SPRINGS)

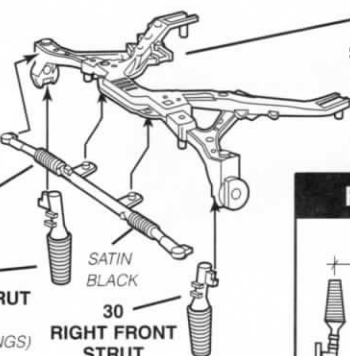

FRONT VIEW

1 3/4"

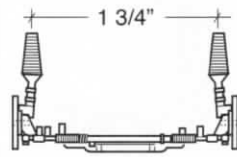

B

35 REAR TORSION BAR
ALUMINUM

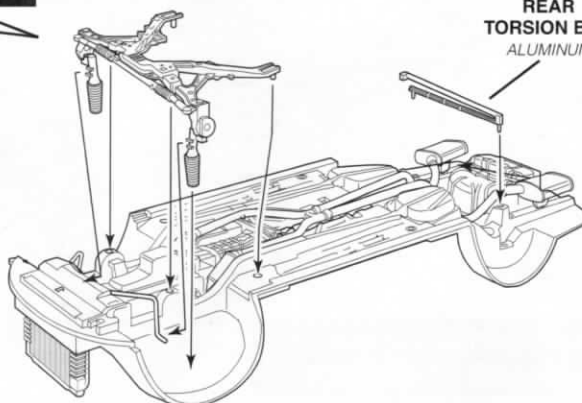

4

SUSPENSION ASSEMBLY CONTINUED

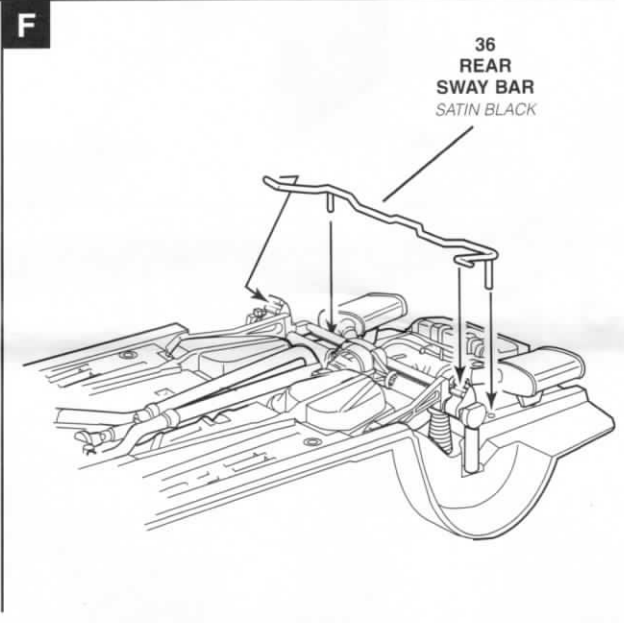
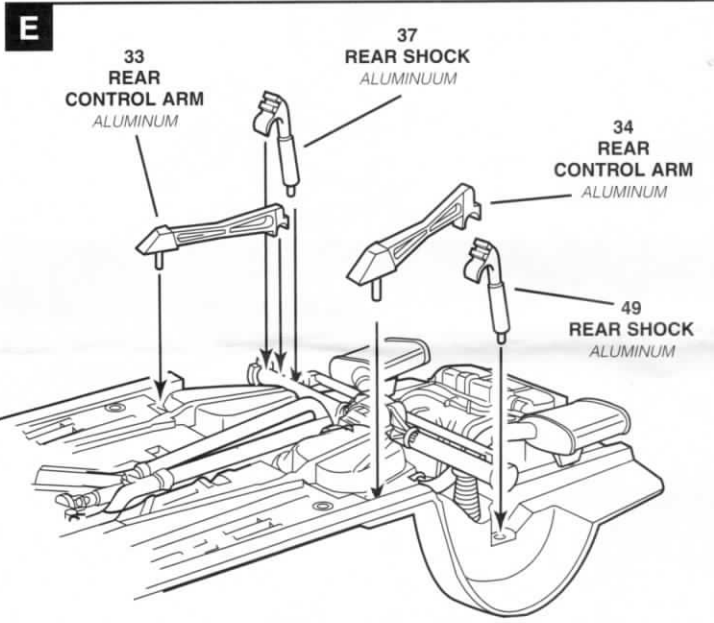
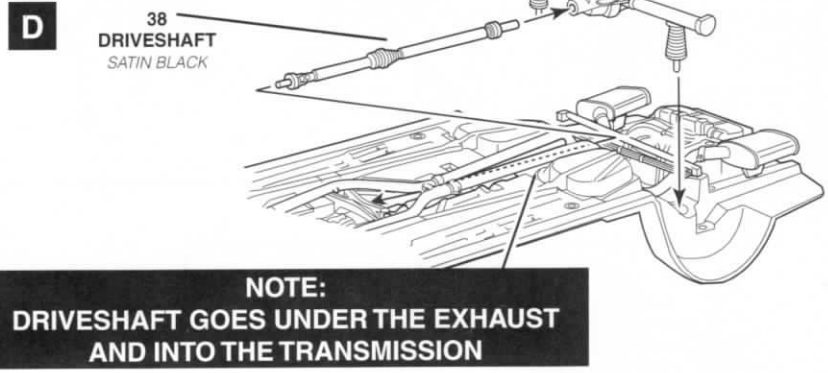
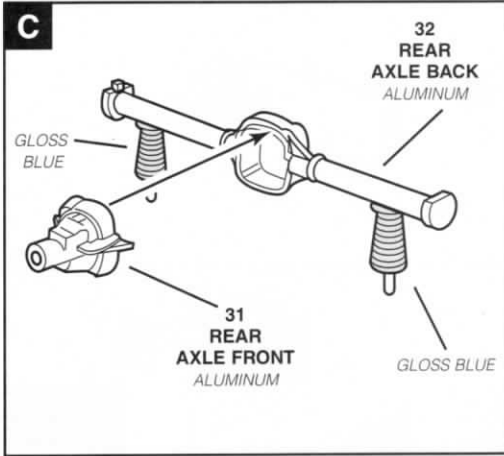

5

DISC BRAKE ASSEMBLY

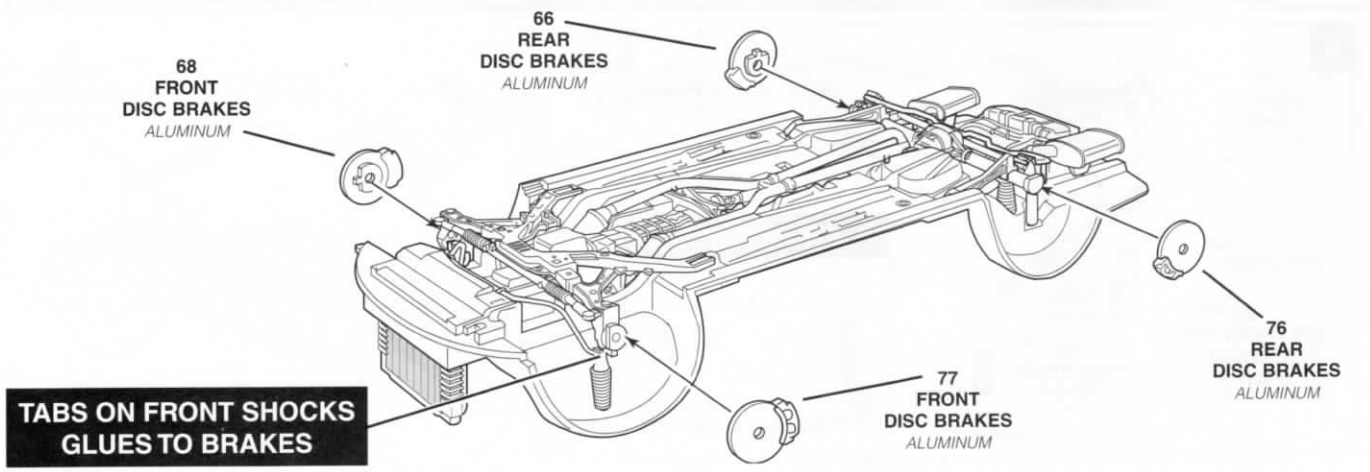

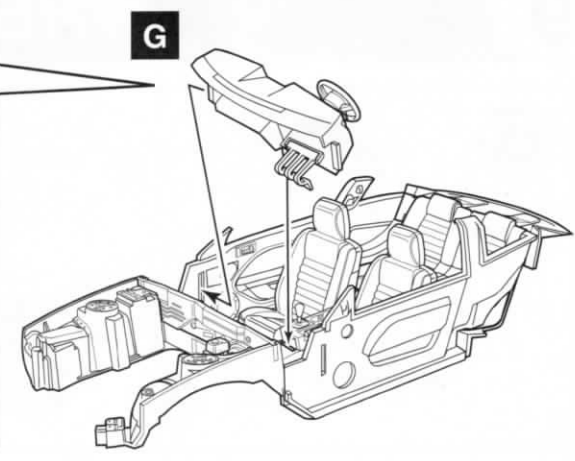
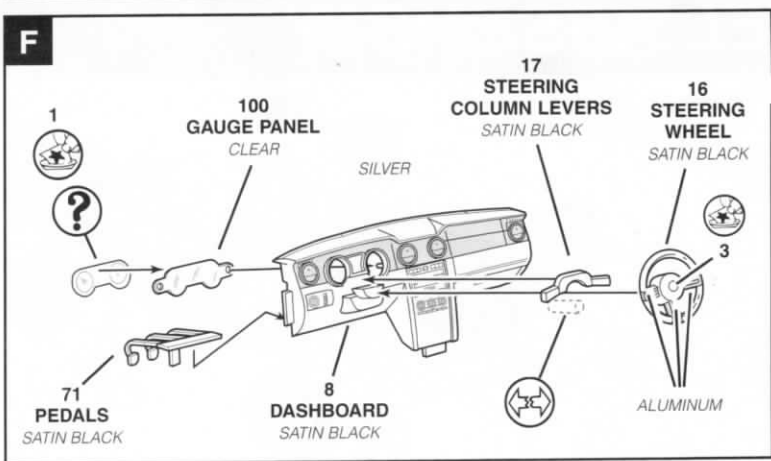
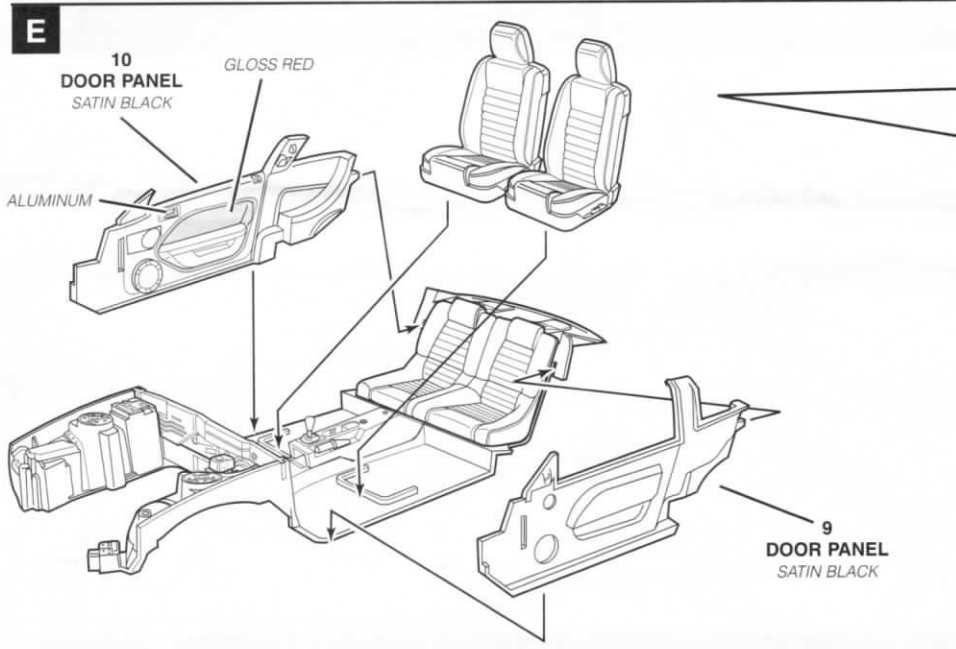
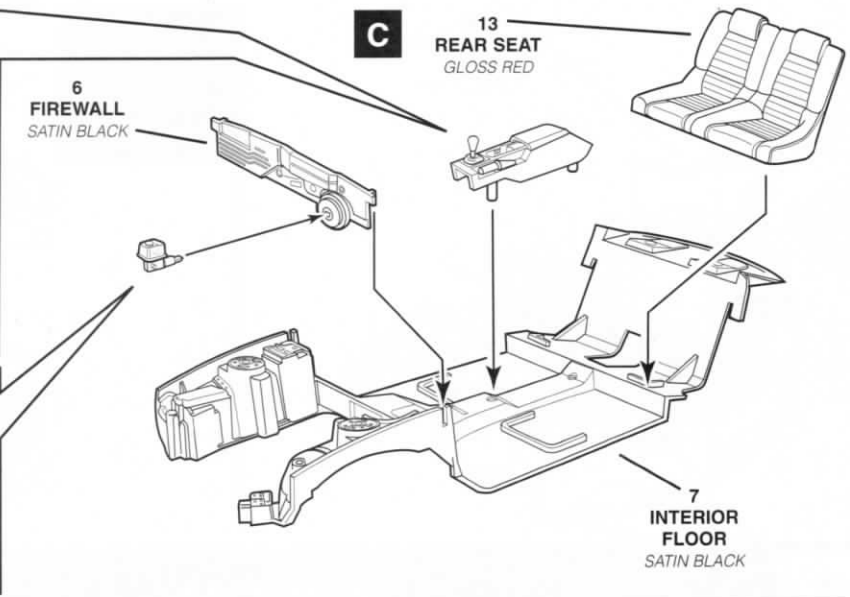
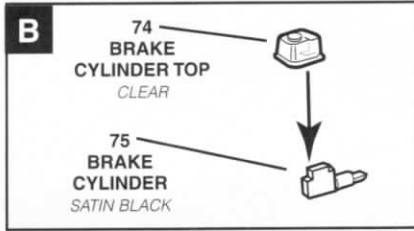
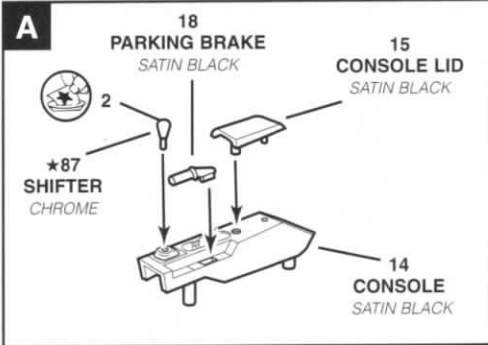

7

UPPER HOSE ASSEMBLY

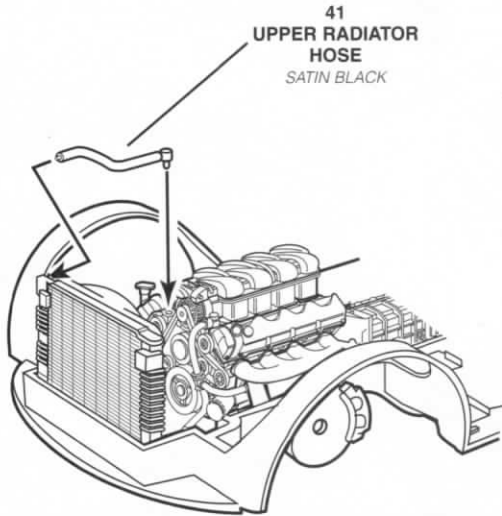

COMPLETED
INTERIOR
TO
CHASSIS

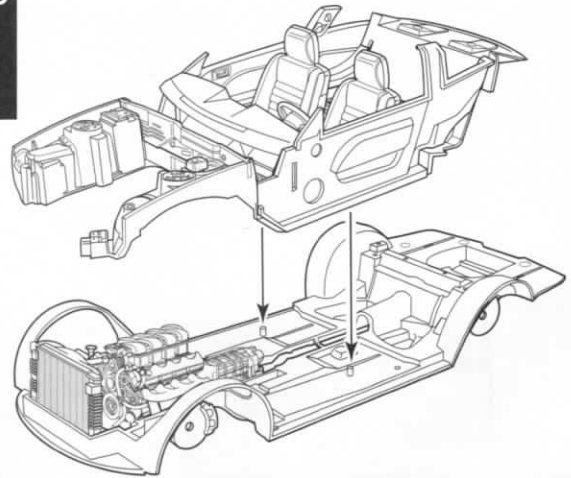

8

WINDOW ASSEMBLY

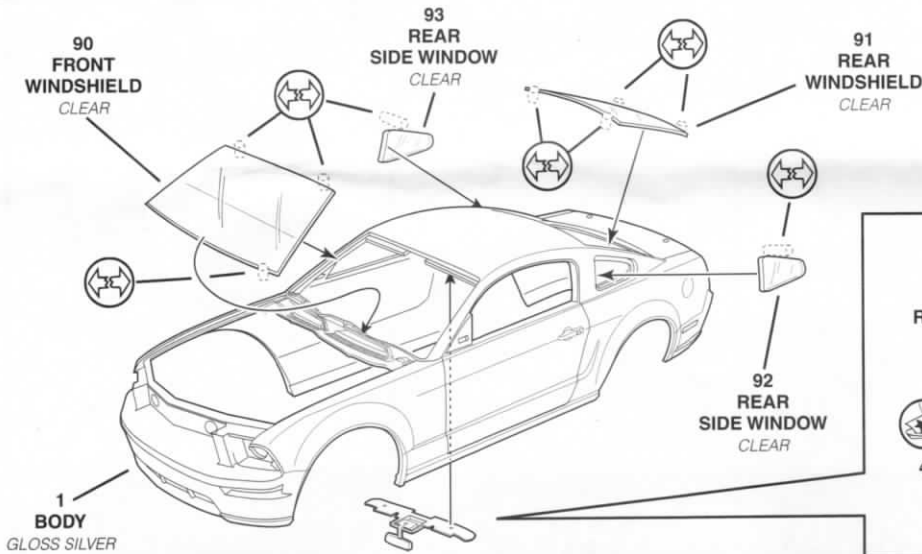

*88
REAR VIEW MIRROR
CHROME



19
VISORS
SATIN BLACK



9

WHEEL ASSEMBLY

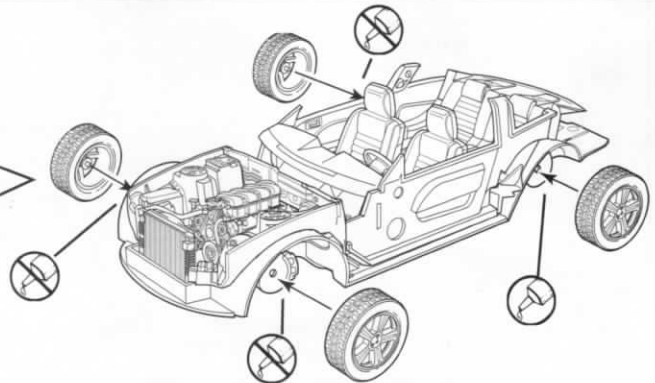
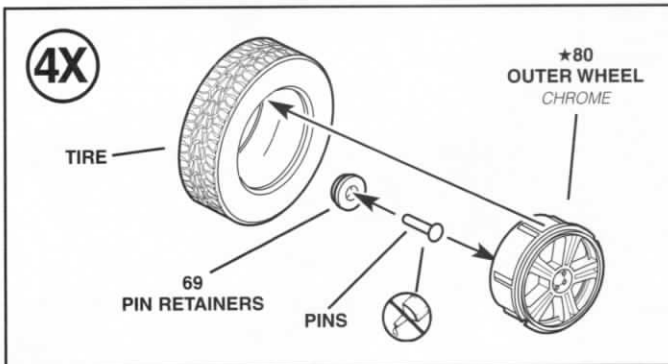

10

FRONT ASSEMBLY

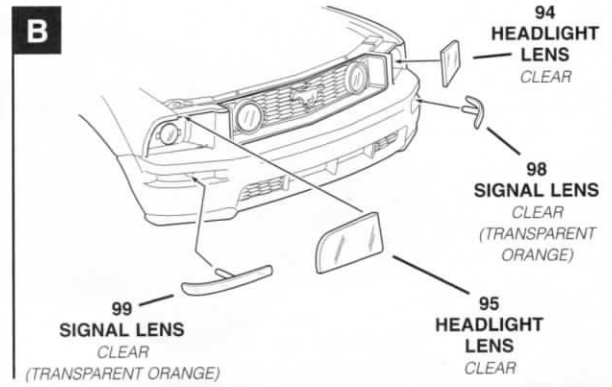
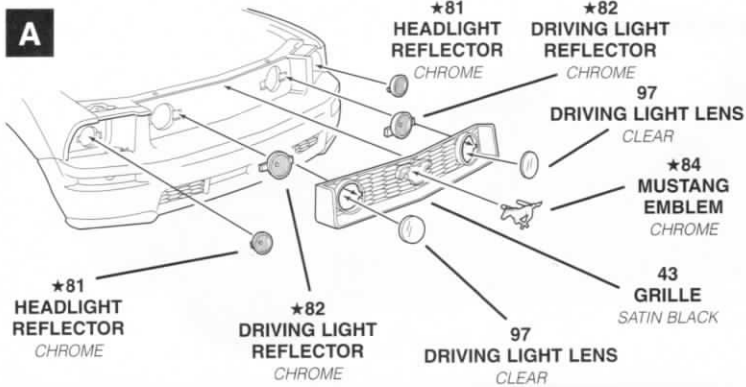

11

REAR / BODY ASSEMBLY

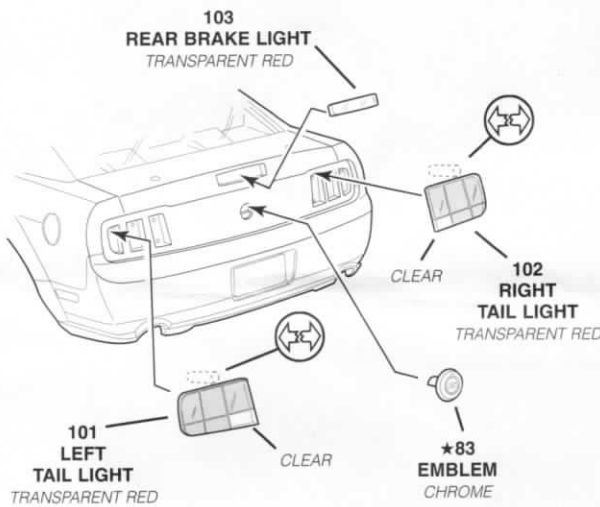

BODY TO COMPLETED CHASSIS

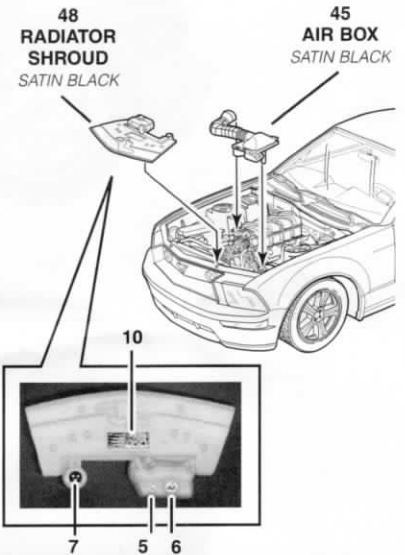
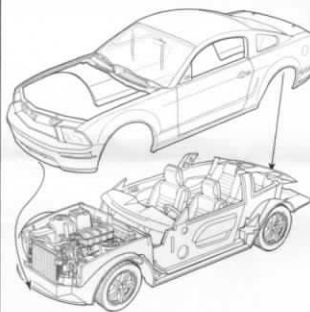

12

FINAL ASSEMBLY

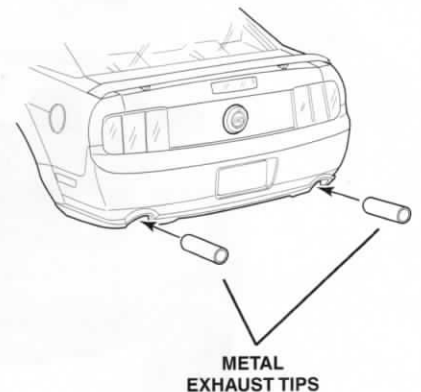
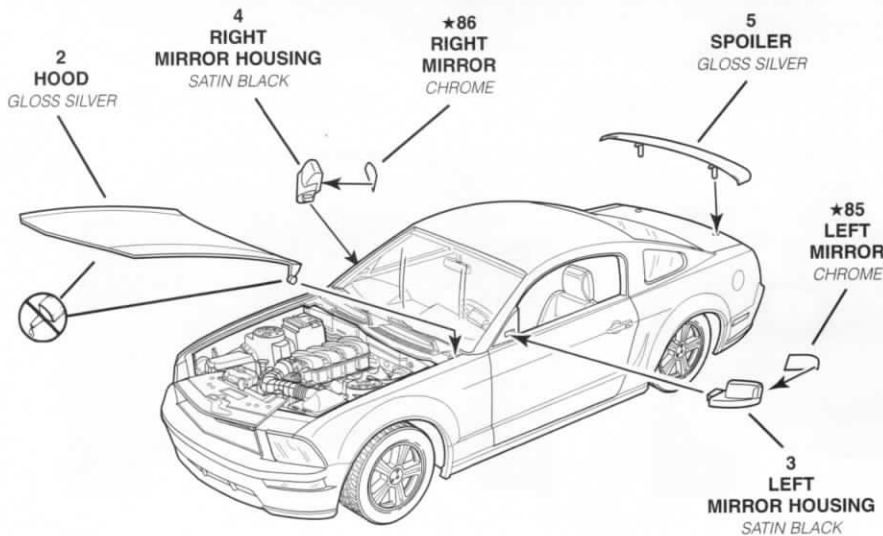

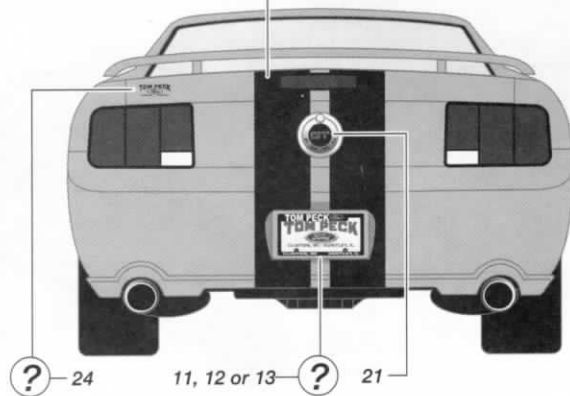
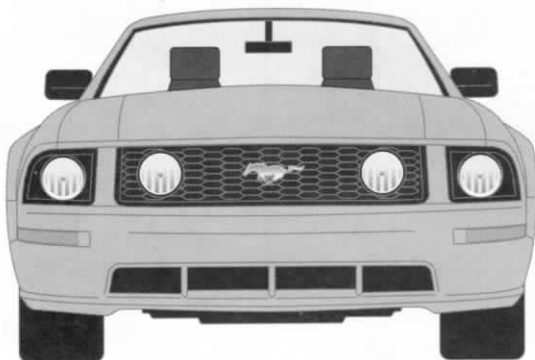
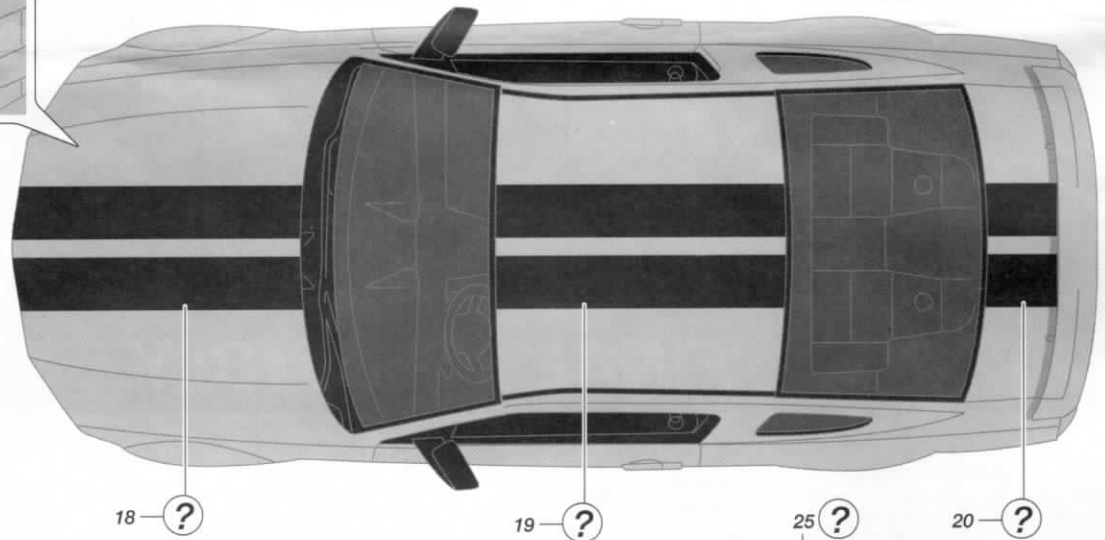
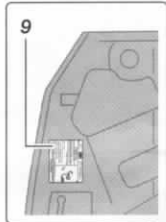
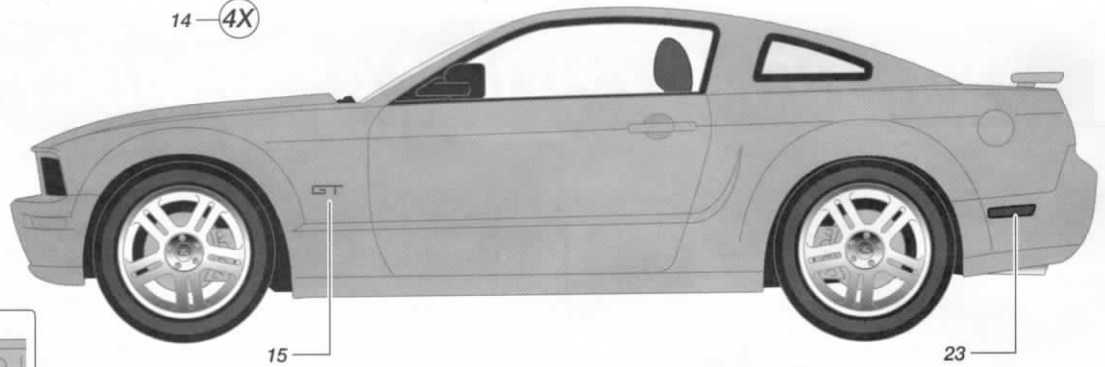
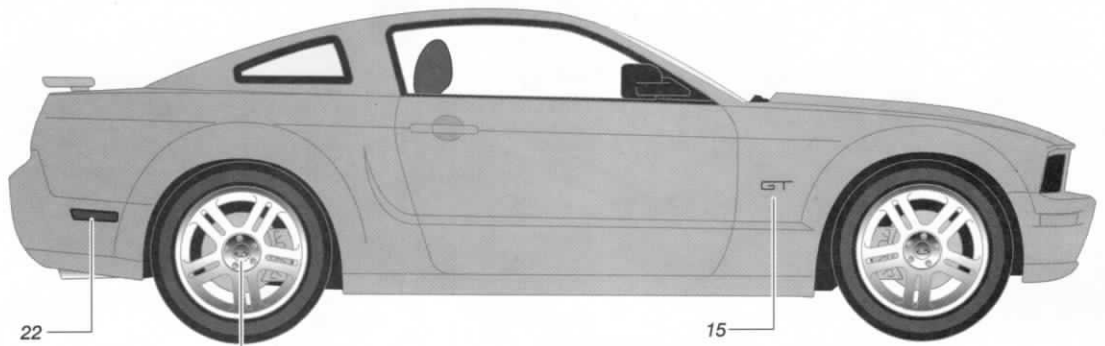



1

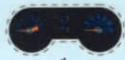

1



1



1



2 3 4 9 10 14 15 22 23 24 25



12



13



11

18



19

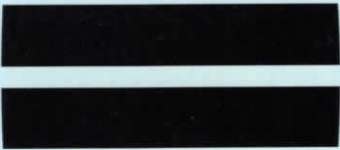

20

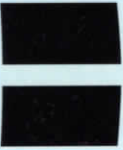

18



19

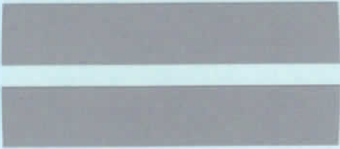

20

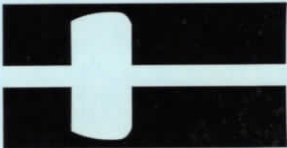
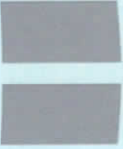

25

