

PE4808

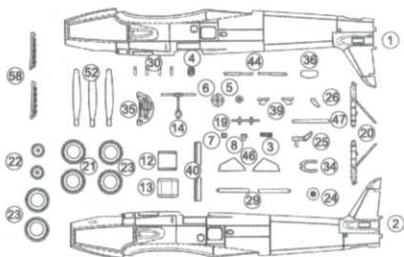
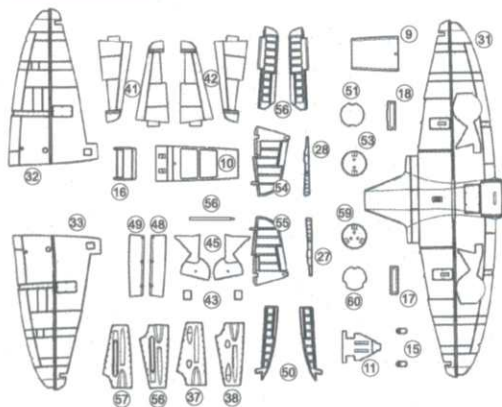
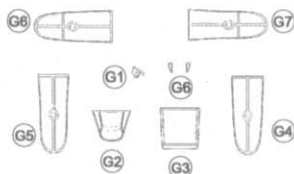

# Heinkel He 112B-0/1/V9

**Plastic edition**

**Kabina  
Canopy**
**Obtisky / decals**

**Barvy / Colours**  
**[AK Real Colors]**
**A** RLM 71/RC275

**C** RLM 65 / RC271

**E** RLM 63 / RC270

**B** RLM 70 / RC274

**D** RED/ RC006

**F** RLM 02 / RC265

**CZ** Heinkel He 112 vznikl v první polovině 30. let 20. století. Jednalo se o jednomístný jednomotorový stíhací dolnoplošník. Byl přímým konkurentem Messerschmittu Bf 109, pro který však neuspěl. Krátkou službu u Luftwaffe zahájil 1. července 1938 u jednotky IV./JG132 během Mnichovské krize. Na základně Oschatz v Sasku sloužilo 12 strojů. Svou činnost letadla He 112B ukončila koncem roku 1938 v Moravské Třebové (Československo), kde se název jednotky změnil na II./JG331 a její letadla byla nahrazena Bf 109C.

**Specifikace:**

Délka: 9,22m; Rozpětí: 9,09m; Výška: 3,82m; Dolet: 1150km; Dostup: 9500m; Max. rychlost: 510km/h.

**EN** The Heinkel He 112 was created in the first half of the 1930s. It was a single-seat, single-engine low-wing fighter. He was a direct competitor of Messerschmitt Bf 109, against which, however, he failed. He 112 began short Luftwaffe service on 1 July 1938 with unit IV./JG132 during the Munich Crisis. 12 machines were in service at the Oschatz base in Saxony. The He112B aircraft ended its operation at the end of 1938 in Moravska Třebova (Czechoslovakia), where the name of the unit changed to II./JG331 and its aircraft replaced by Messerschmitt Bf 109C.

**Specification:**

Length: 9,22m; Span: 9,09m; Height: 3,82m; Range: 1150km; Ceiling: 9500m; Max. speed: 510km/h.

Source: Heinkel He 112 in action, Squadron signal publication, by Dénes Bernád,

[https://cs.wikipedia.org/wiki/Heinkel\\_He\\_112](https://cs.wikipedia.org/wiki/Heinkel_He_112)

 Heinkel He 112B-1: <https://www.valka.cz/Heinkel-He-112-B-1-18593>

 LF Models, Ladislav Fojtí, Nový Malín 711, 788 03 Nový Malín, Czech Republic  
[www.lfmodels.com](http://www.lfmodels.com), e-mail: [lfmodels@lfmodels.com](mailto:lfmodels@lfmodels.com), mobile: +420-724343629

# A.

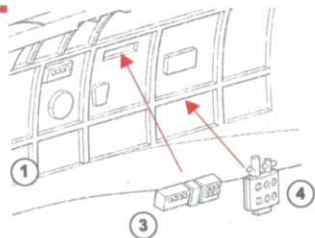

# B.

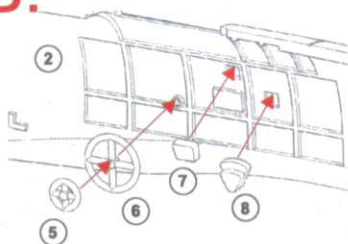

# C.

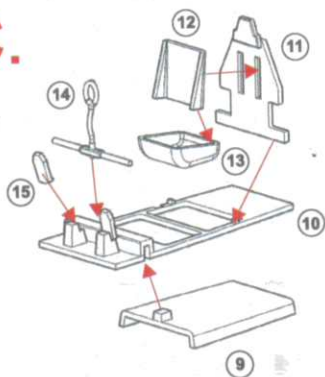

# D.

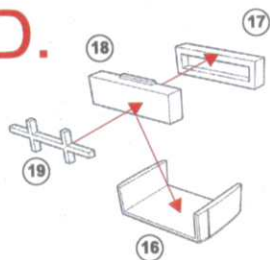

# E.

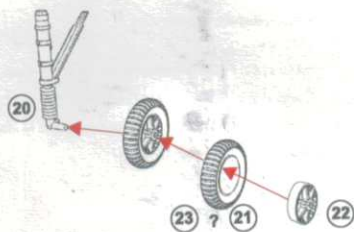

# F.

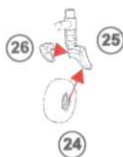

# G.

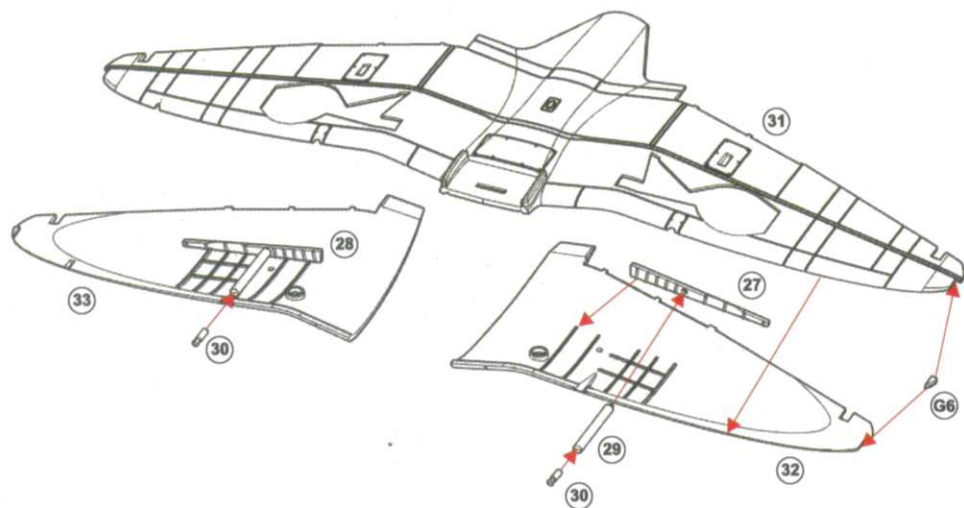

# H1.

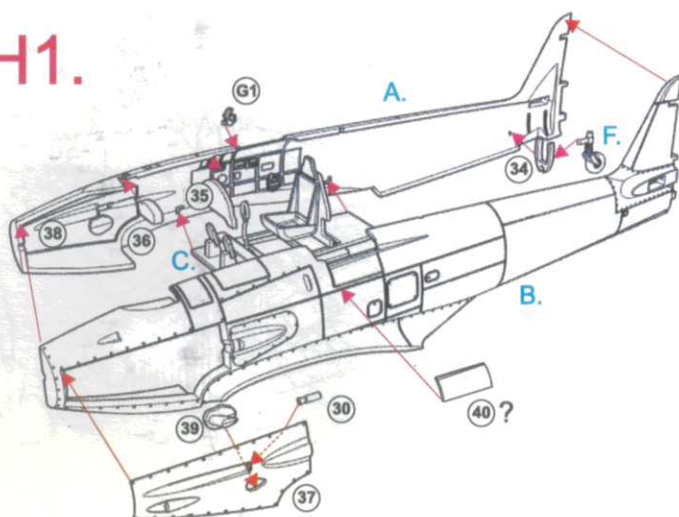

# H2.

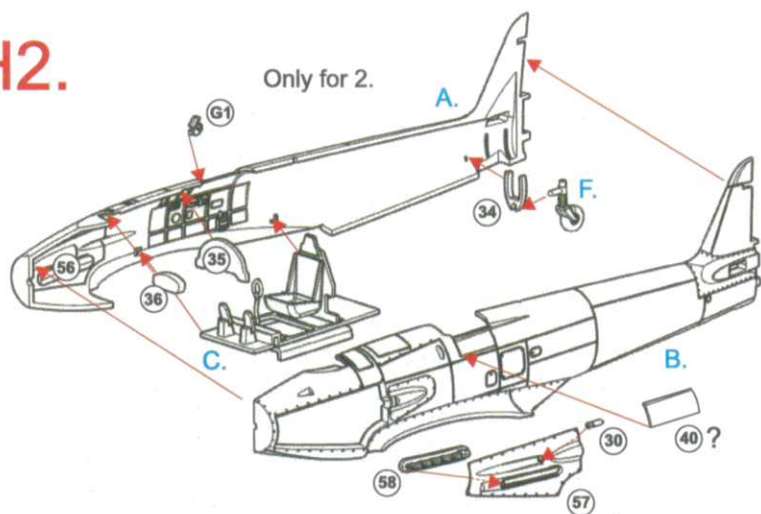

# I.

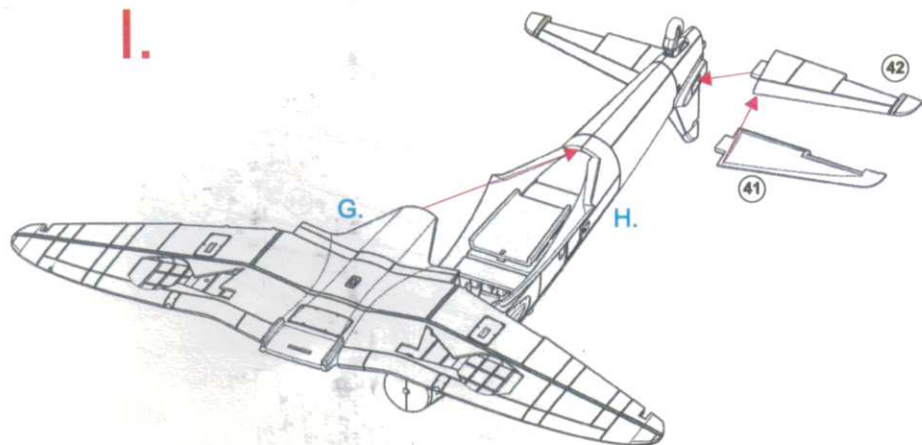

J.

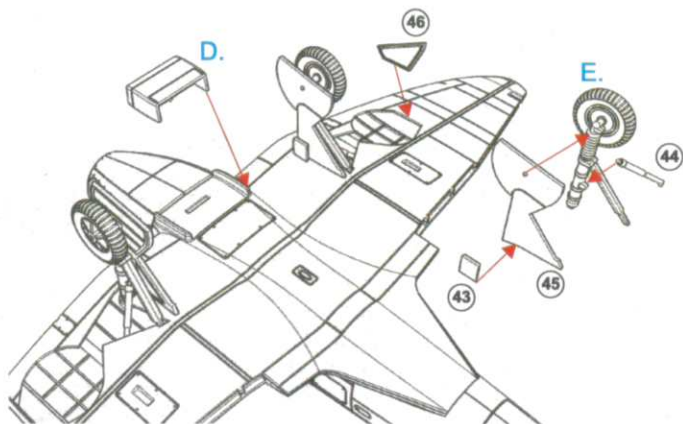

K1.

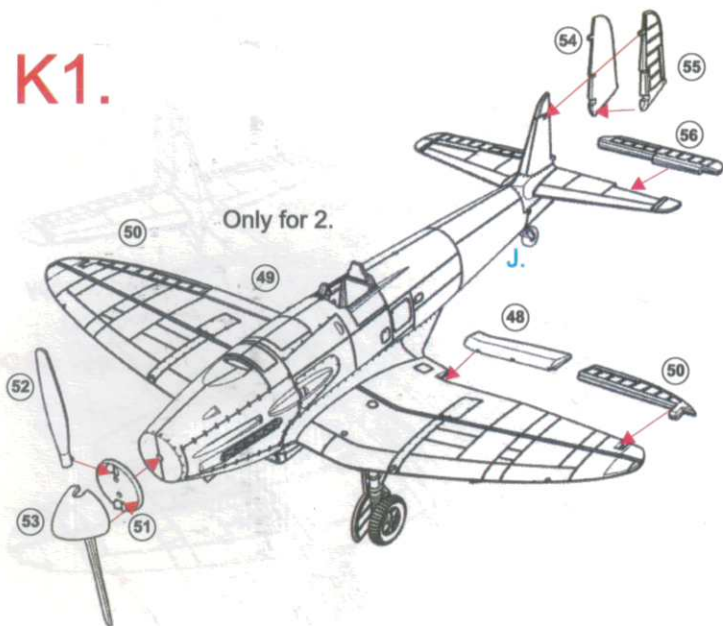

# K2.

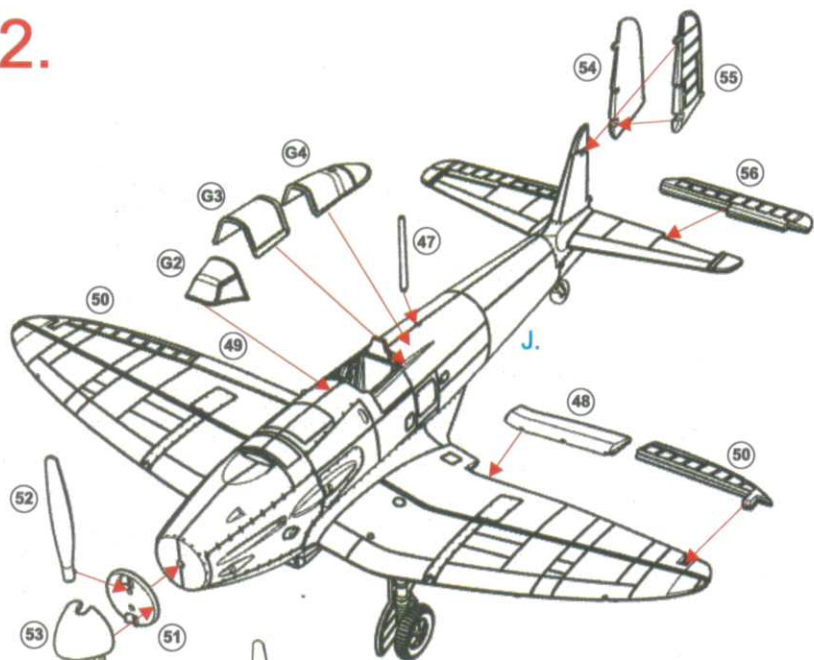

# L.

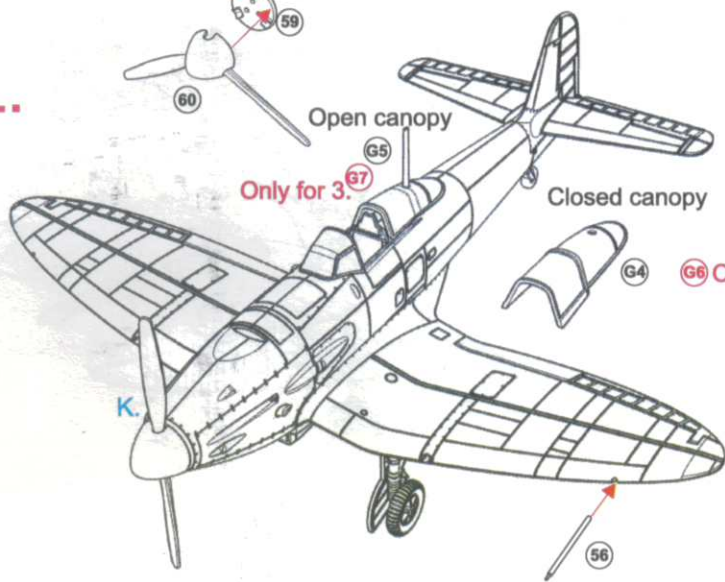

# Dostupné sety/Available sets/Masky/Masks:

CM4802 CANOPY MASK:

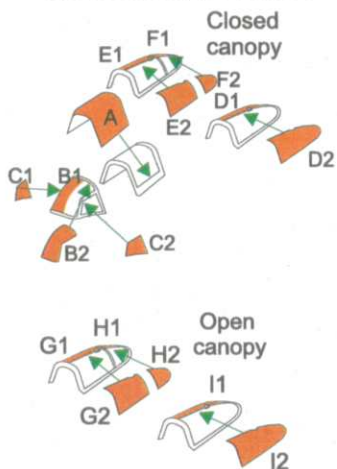

M48104 CAMOUFLAGE MASK:

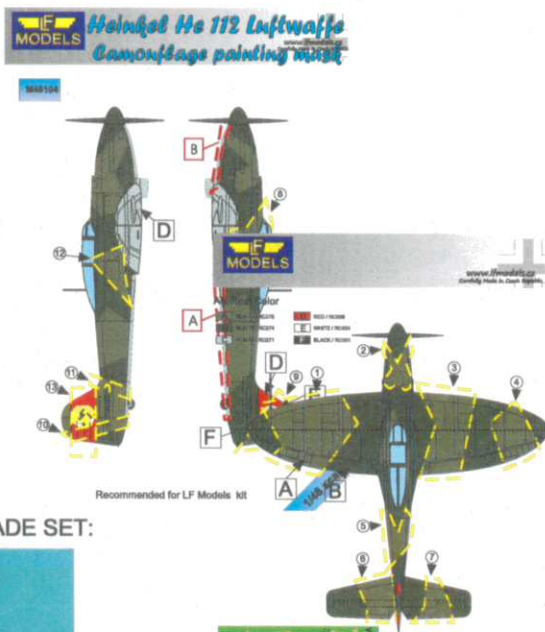

LF3D4802 HEINKEL HE 112B-0 UGRADE SET:



LF3D4802 HEINKEL HE 112B-0 UGRADE SET:

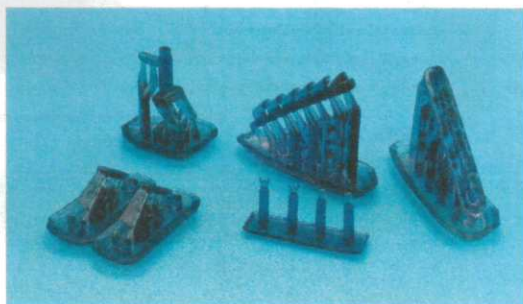

# Painting and marking

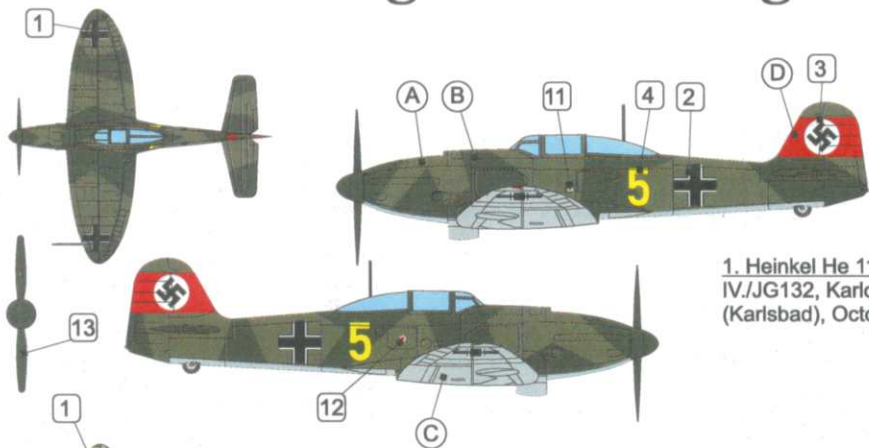

1. Heinkel He 112B-0  
IV./JG132, Karlovy Vary  
(Karlsbad), October 1938

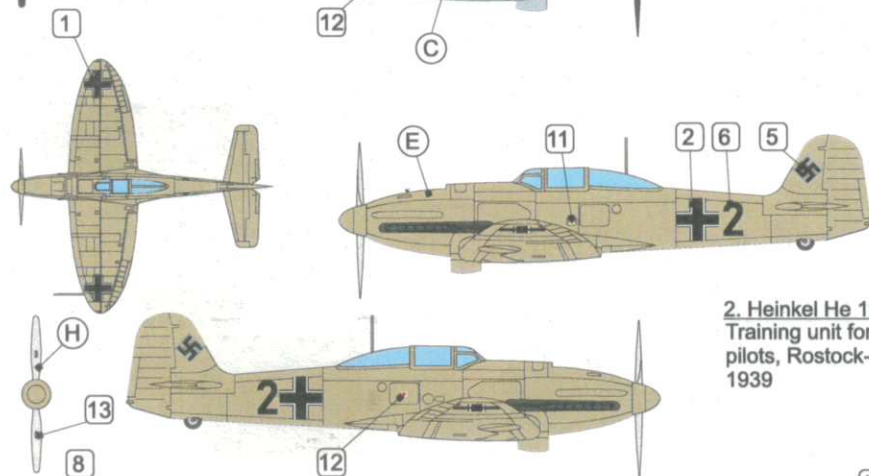

2. Heinkel He 112B-1  
Training unit for Romanian  
pilots, Rostock-Marienehe,  
1939

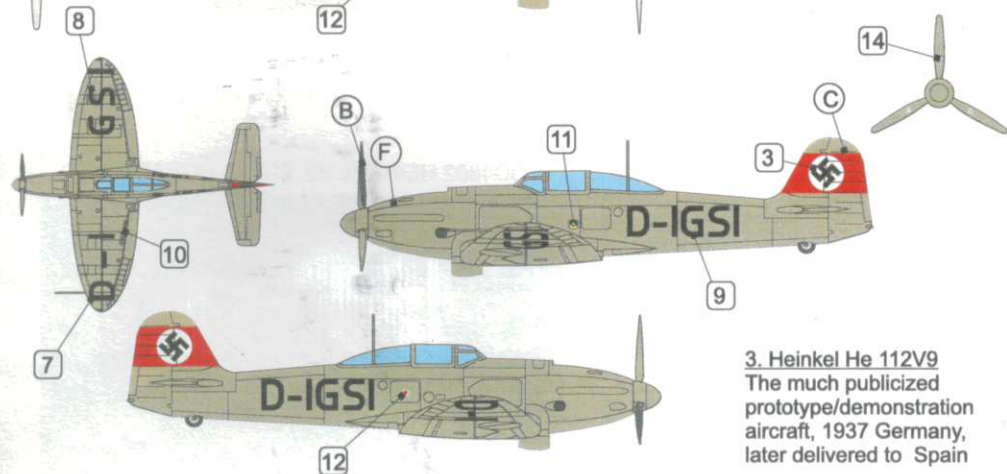

3. Heinkel He 112V9  
The much publicized  
prototype/demonstration  
aircraft, 1937 Germany,  
later delivered to Spain