

BRITISH COMMONWEALTH ARMED FORCES, WORLD WAR II

C.M.P. LIGHT TRUCK

1:35 SCALE PLASTIC MODEL KIT WITH 6-POUNDER GUN AND CREW
ASSEMBLY INSTRUCTION

Peerless

MAX

ITEM No.3508



BEFORE ASSEMBLING

*Before you begin to assemble your model, read the instructions carefully, Familiarize yourself with the part numbers and their location on the "trees". Detach part from "tree" only when part is to be used.

*A sharp modeling knife or wire cutter is the "best" way to remove small parts from "trees". Do not attempt to "twist" parts off.
*Test fit parts together before cementing them. Apply cement carefully, avoiding excess amounts.

*When applying decals, cut decals neatly from sheet and place pieces in small bowl of water for a few seconds. Then place decal in

position on model. Decal can be moved slightly with model knife point or stick end of paint brush. When decal is in exact position, blot with tissue for firm bond.

*It is best to spray paint model Desert Sand or Dark Green overall first. Then paint individual parts (tools, seats, dash panel, tires, etc) with paint brush, in desired color.

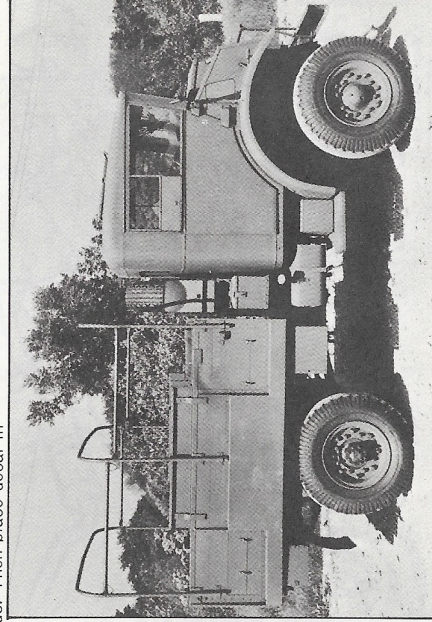

1 VEHICLE UNDERSIDE ASSEMBLY (PART ONE)

REAR AXLE

B46 FRONT AND REAR SPRINGS

FRONT AXLE

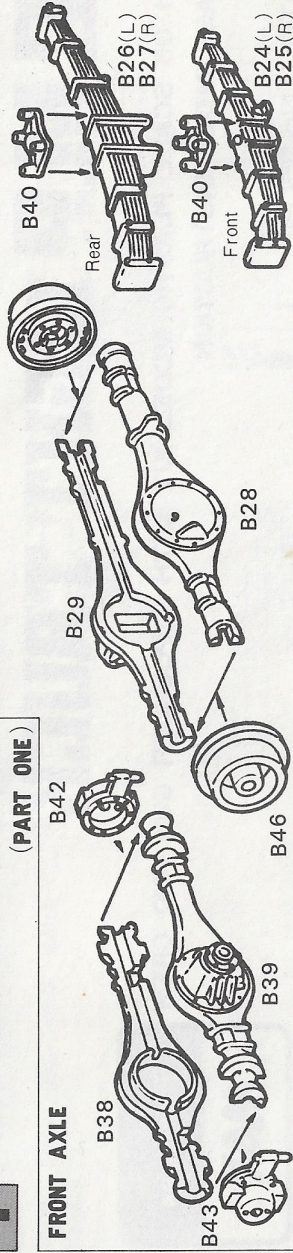

Note: right and left springs are different

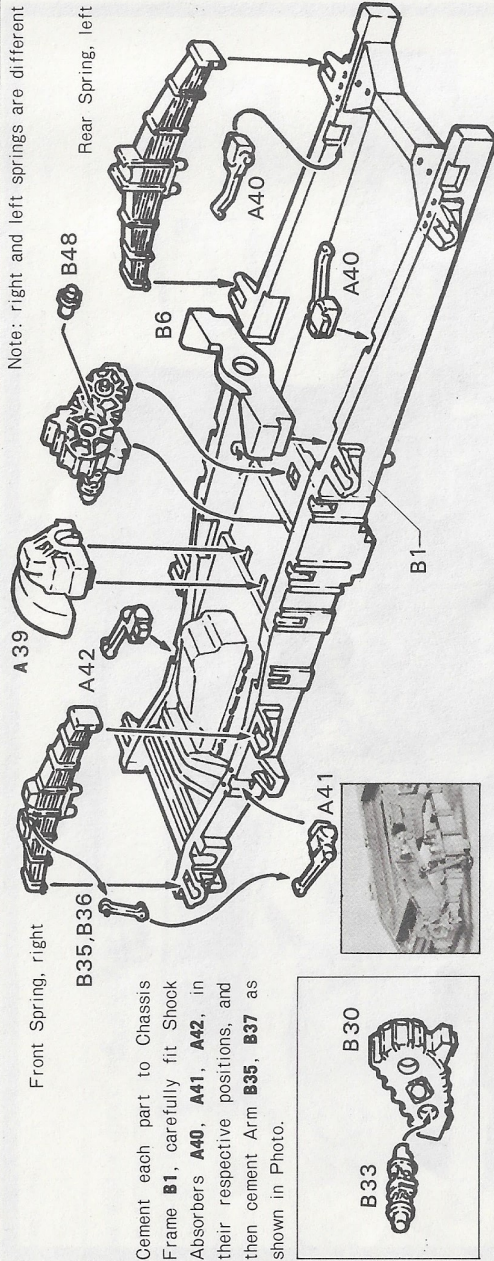

Cement each part to Chassis Frame **B1**, carefully fit Shock Absorbers **A40**, **A41**, **A42**, in their respective positions, and then cement Arm **B35**, **B37** as shown in Photo.

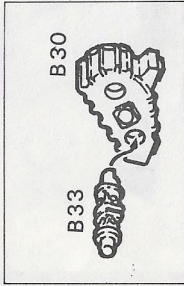

2 VEHICLE UNDERSIDE ASSEMBLY (PART TWO)

Front and Rear Propeller Shafts **B31** and **B32** must be put in place and cemented together at the same time as the Assembled Front and Rear Axles.

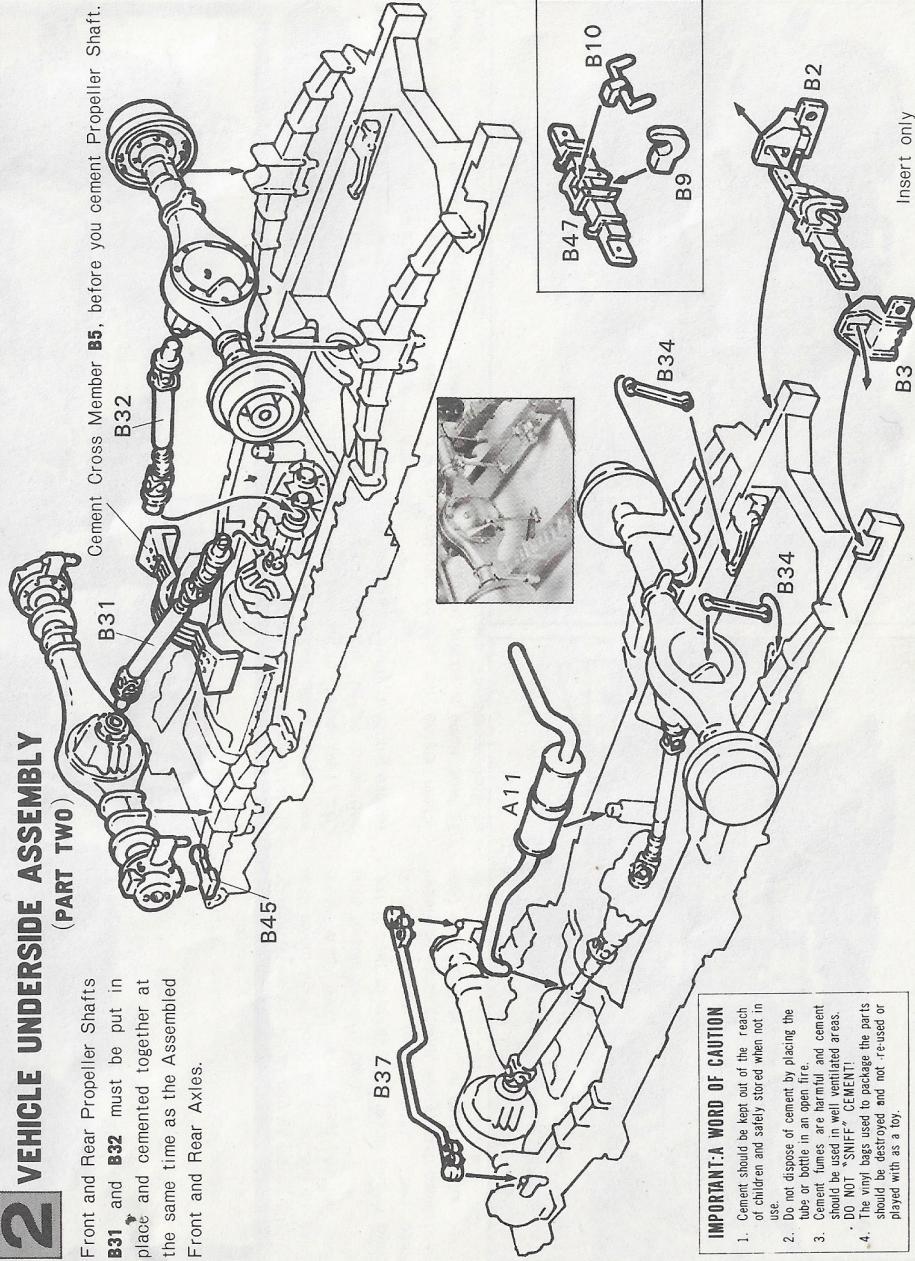

IMPORTANT: A WORD OF CAUTION

1. Cement should be kept out of the reach of children and safely stored when not in use.
2. Do not dispose of cement by placing the tube or bottle in an open fire.
3. Cement fumes are harmful and cement should be used in well ventilated areas. DO NOT "SNIFF" CEMENT!
4. The vinyl bags used to package the parts should be destroyed and not re-used or played with as a toy.

3 ACCESSORIES

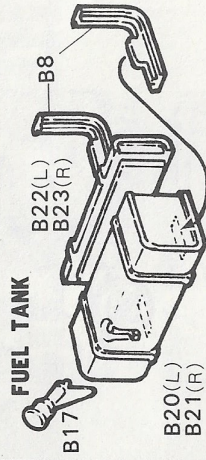

Note: right and left Fuel tanks are different.

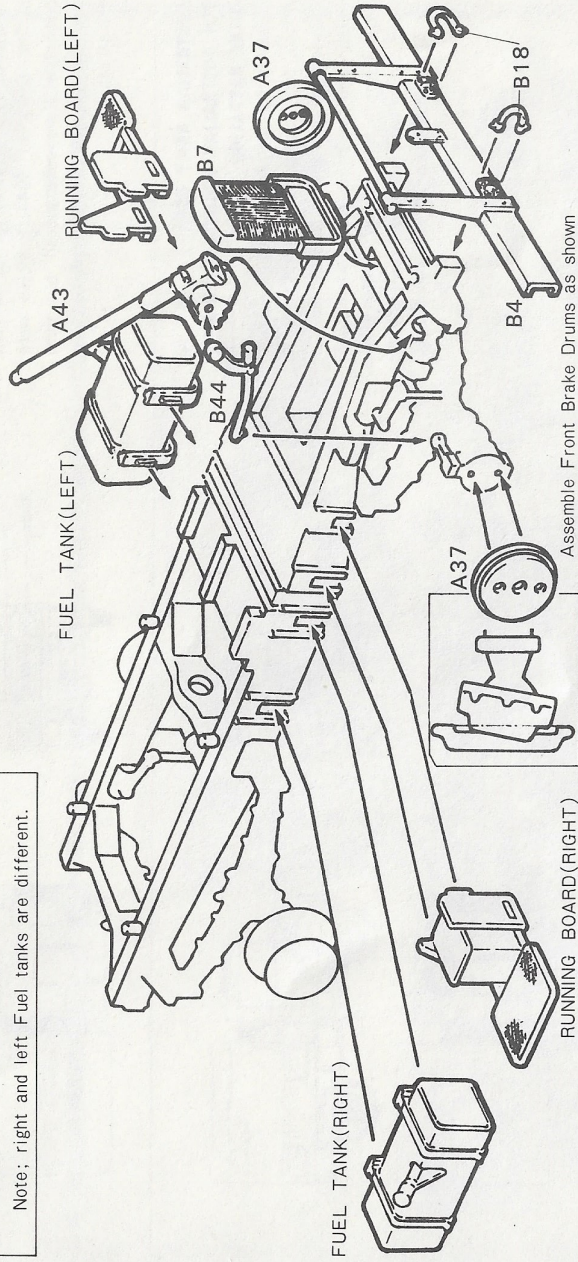
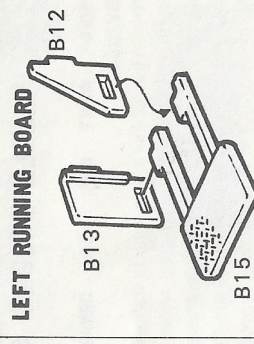
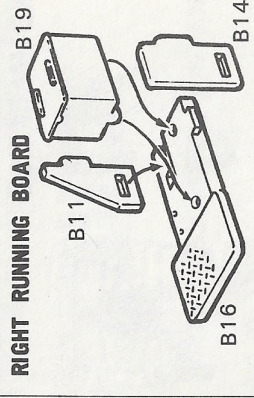

Assemble Front Brake Drums as shown

4 CEMENT WHEEL HALVES

Cement Front and Rear Wheels, note that Front Wheels have rounded Wheel Hubs. **D4** is for Spare tire. Push metal shafts through Axle and into Wheel hubs. Tap Wheel Hubs with small hammer. Be sure Wheel rotate freely.

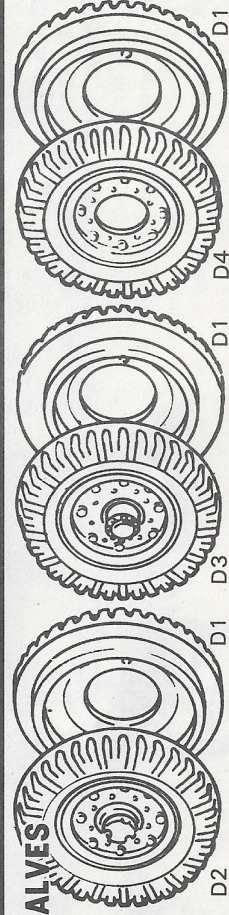

5 CAB ASSEMBLY (PART ONE)

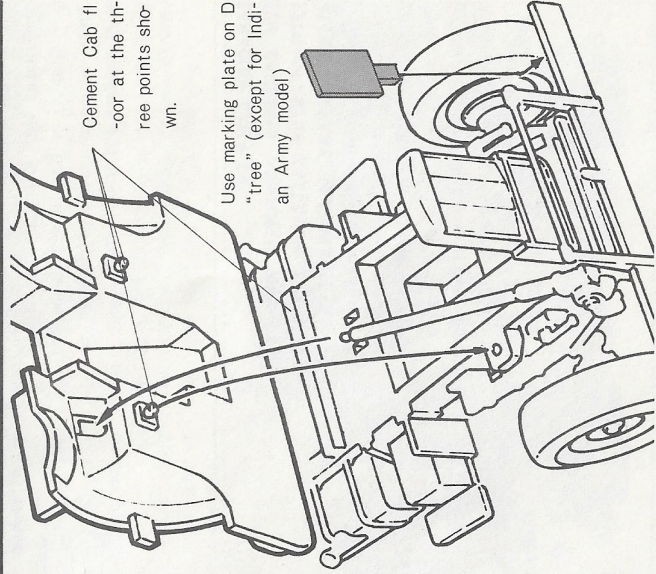
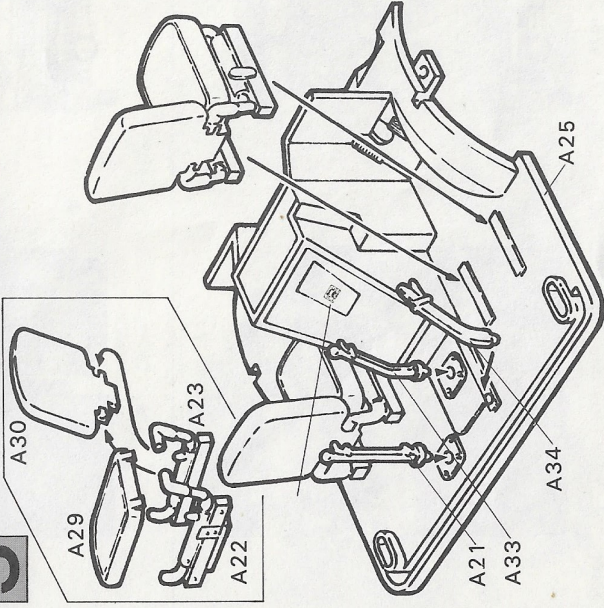

Cement Cab floor at the three points shown.

Use marking plate on D "tree" (except for Indian Army model)

6 CAB ASSEMBLY (PART TWO)

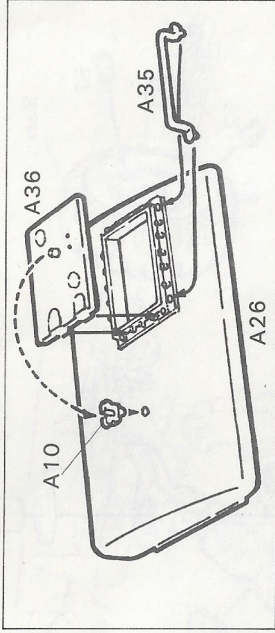
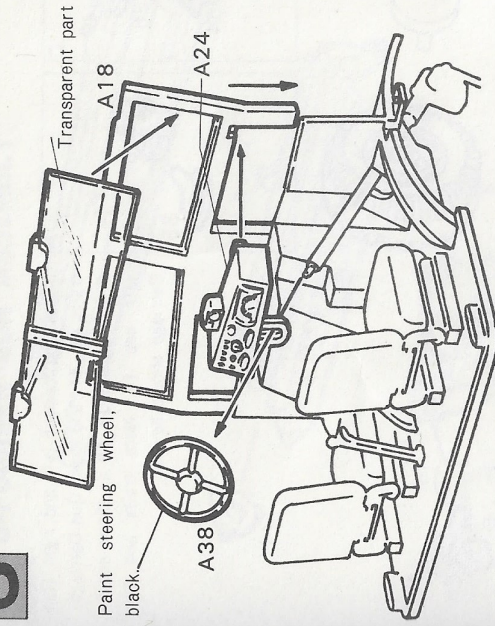
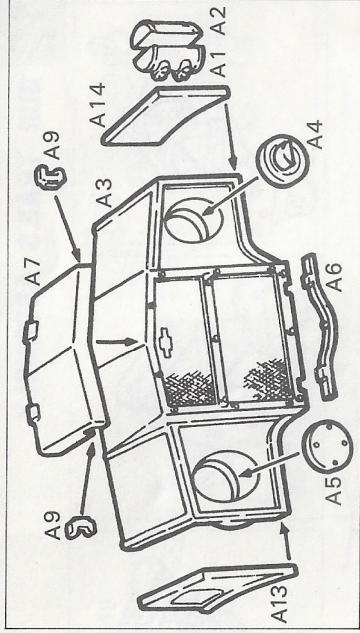

Observation Hatch **A36** should be cemented open or closed, as desired

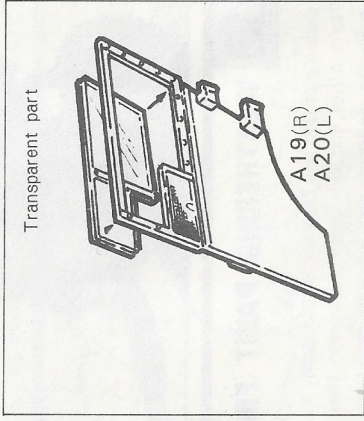
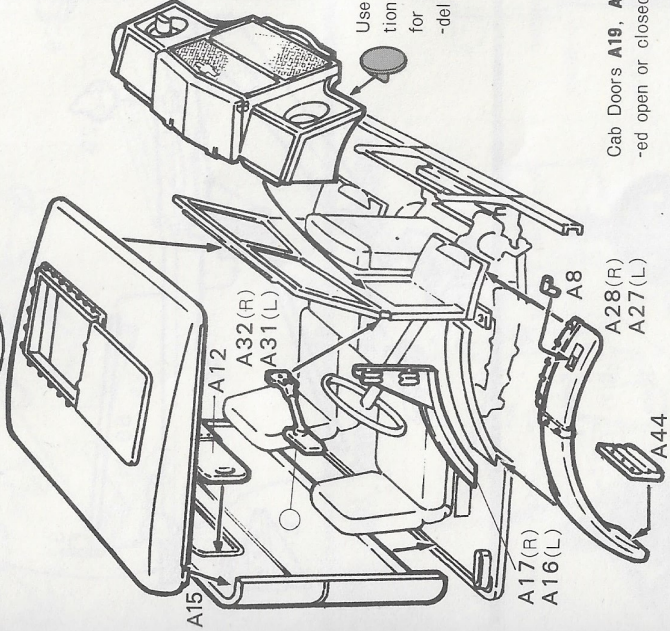

Cab Doors **A19**, **A20** should be cemented open or closed, as desired.

7 CARGO BODY ASSEMBLY (PART ONE)

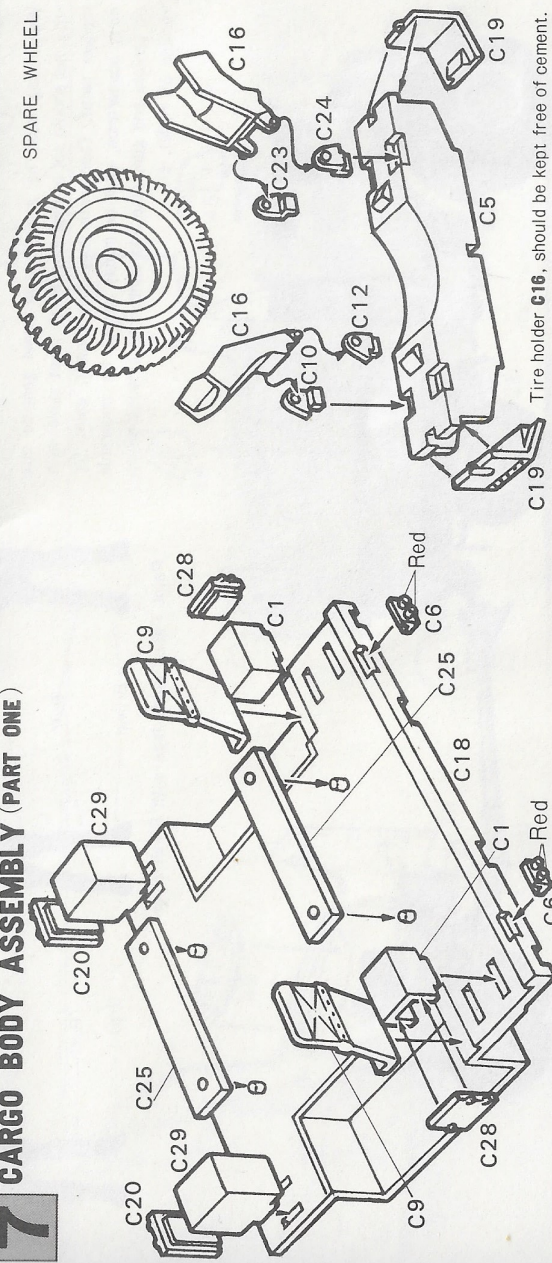

8 CARGO BODY ASSEMBLY (PART TWO)

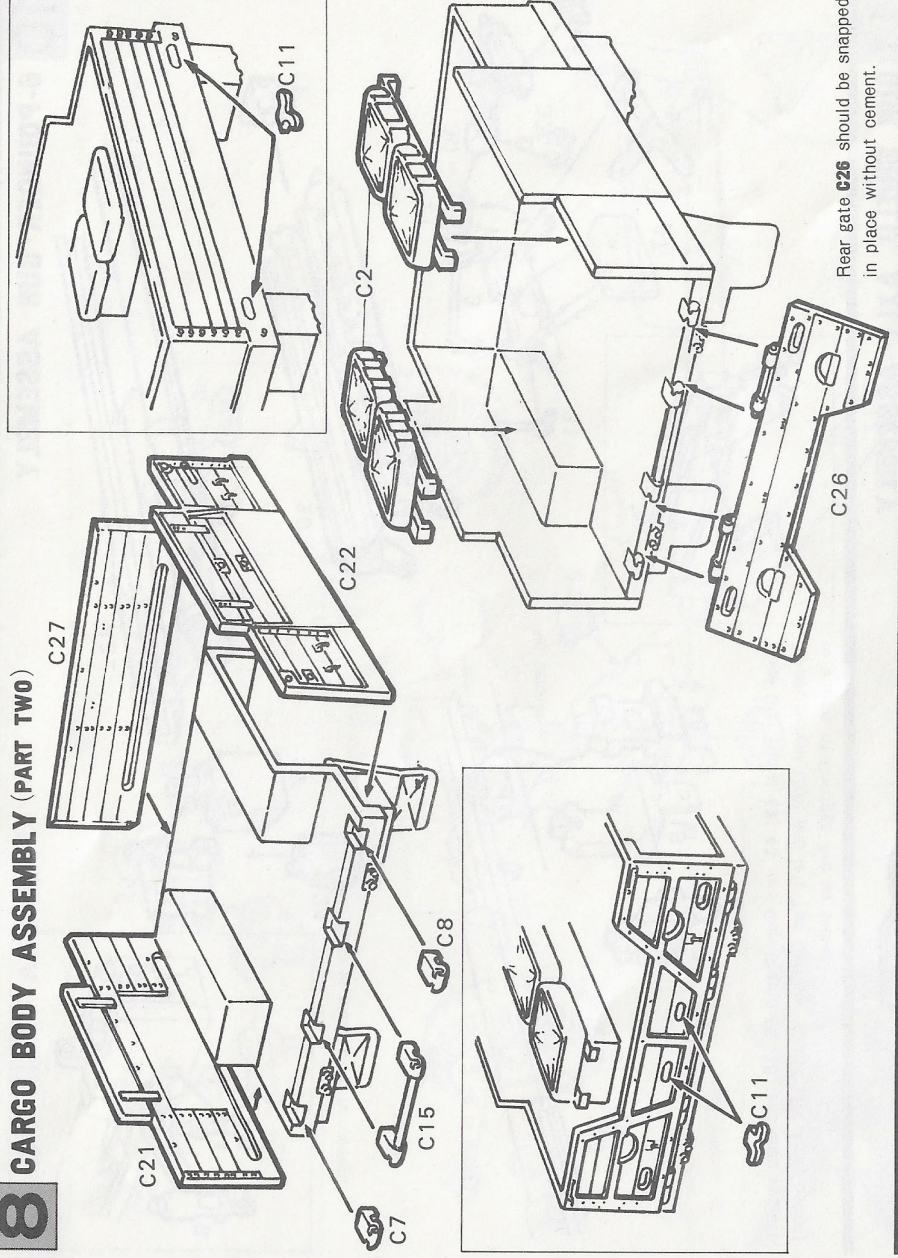

Rear gate **C26** should be snapped in place without cement.

9 MOUNTING CARGO BODY

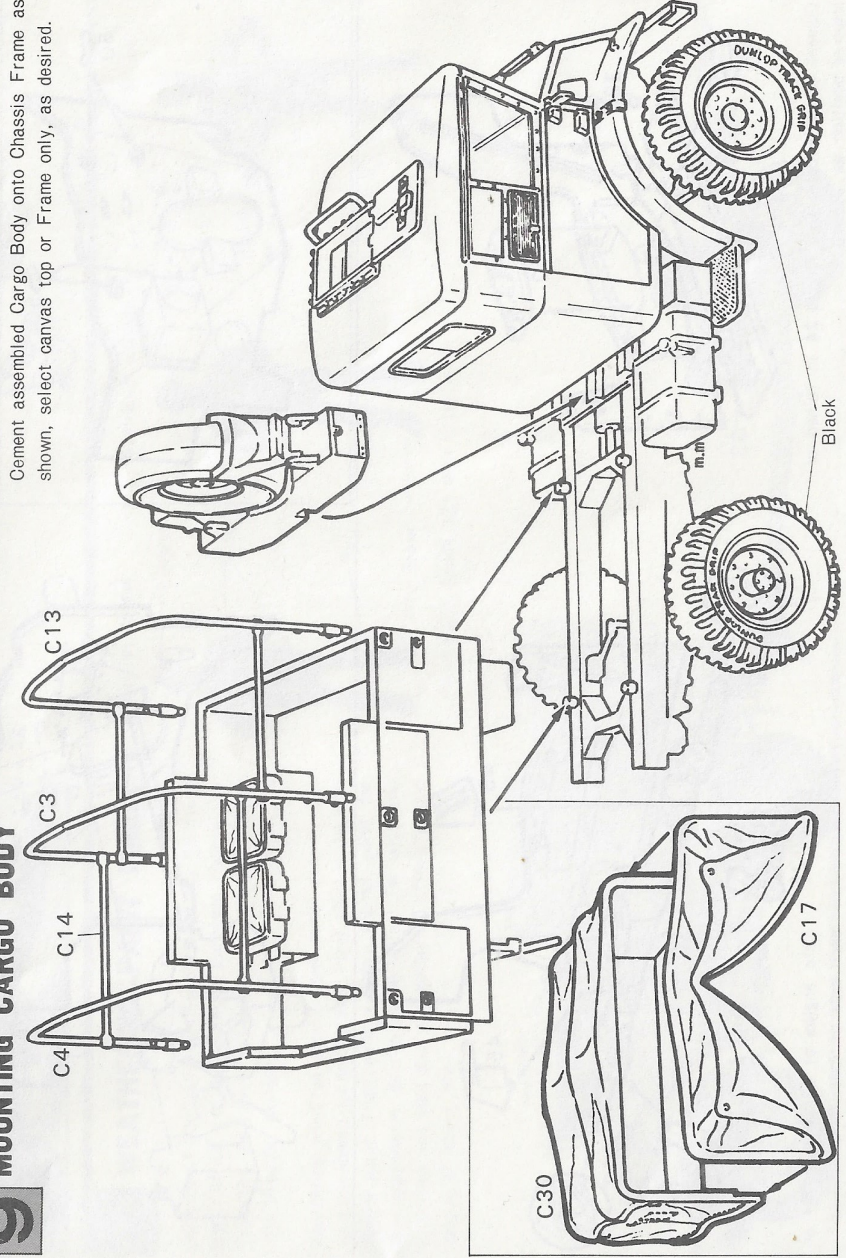

Cement assembled Cargo Body onto Chassis Frame as shown, select canvas top or Frame only, as desired.

10 6-POUNDER GUN ASSEMBLY

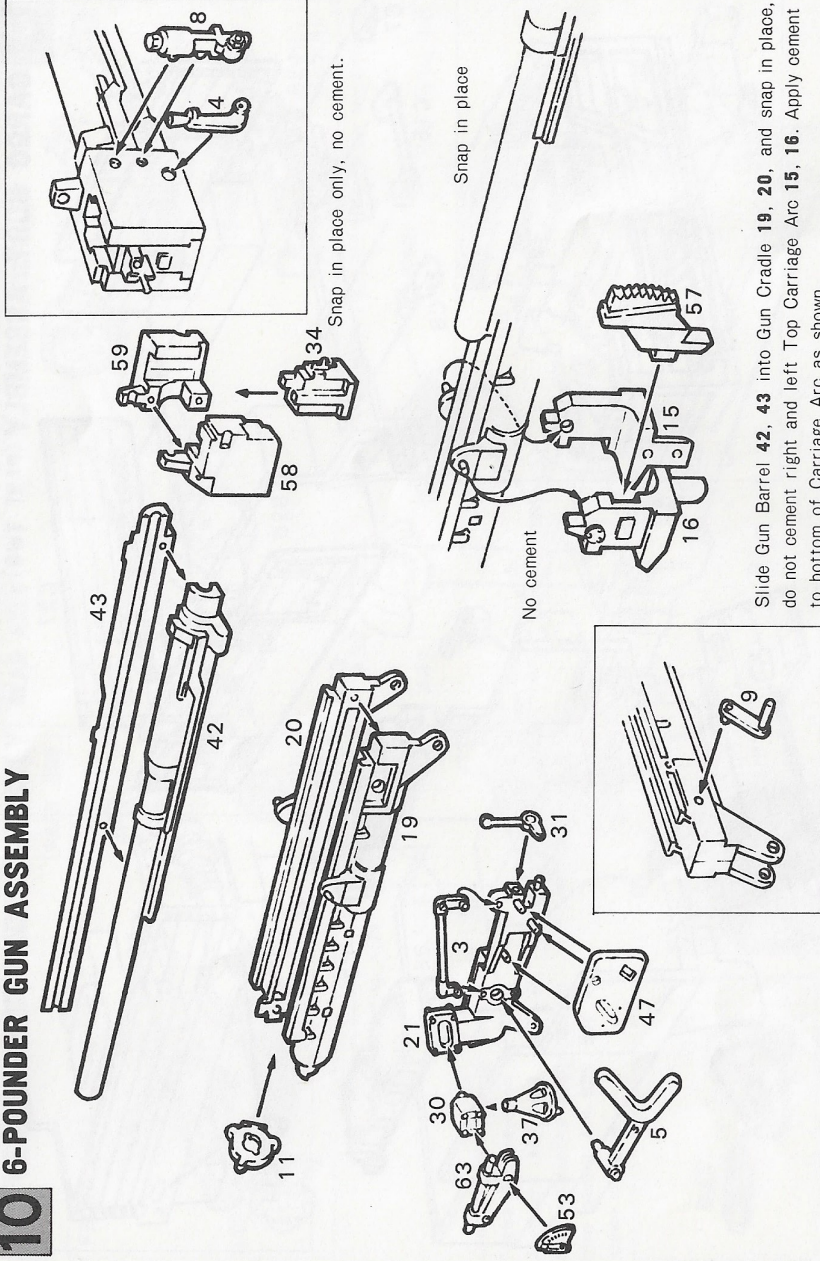

Slide Gun Barrel **42**, **43** into Gun Cradle **19**, **20**, and snap in place, do not cement right and left Top Carriage Arc **15**, **16**. Apply cement to bottom of Carriage Arc as shown.

11 GUN SHIELD, AXLE ASSEMBLY

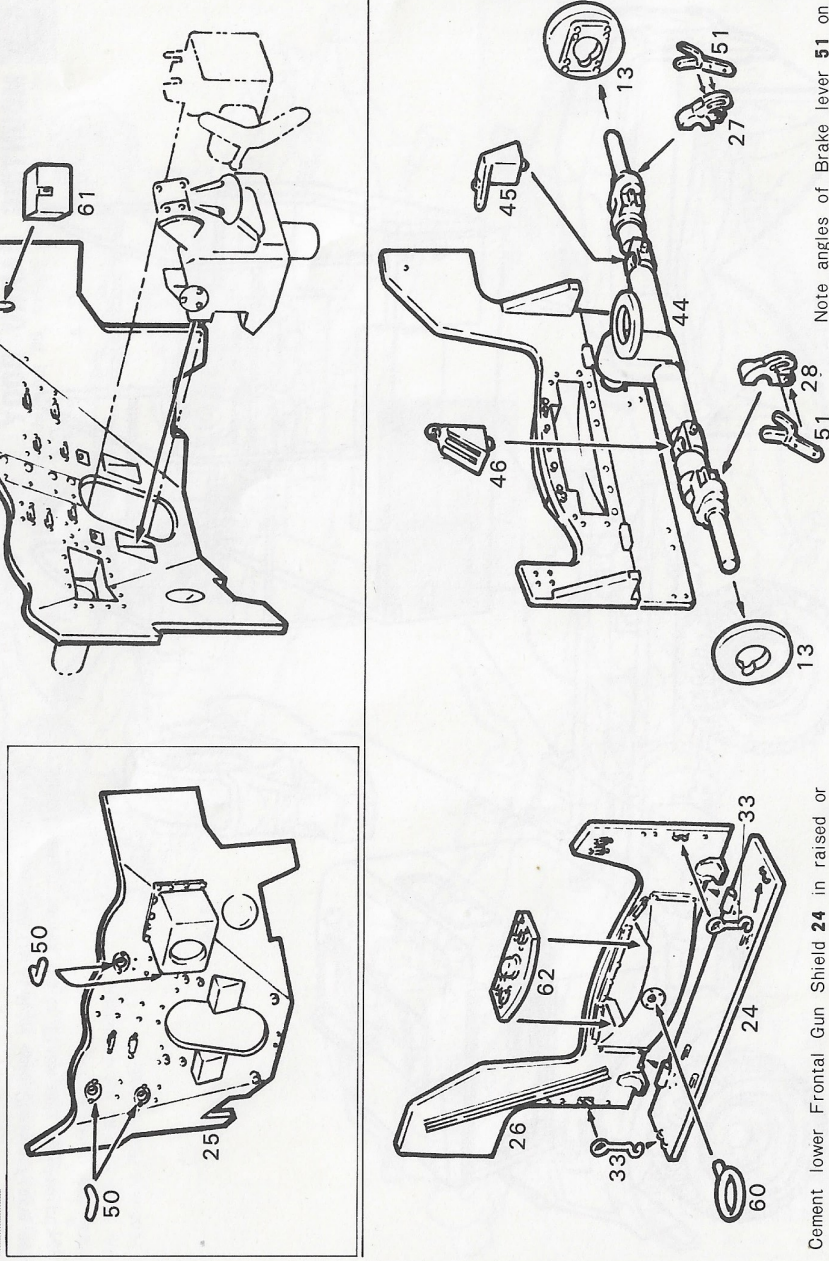

Cement lower Frontal Gun Shield **24** in raised or lowered position as desired.

Note angles of Brake lever **51** on each side of Axle.

12 GUN TRAILS ASSEMBLY

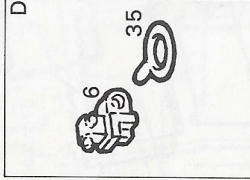
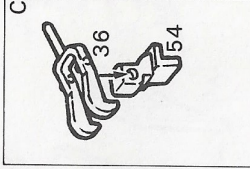
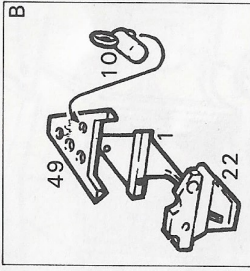
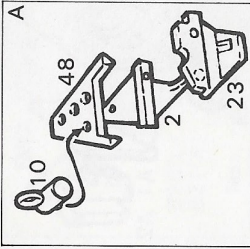

Insert and cement left and right Gun trails **40**, **41**, and lower Gun Carriage Arc into parts **38**, **39** as shown and fix with cap **14**. Note trails and Gun Carriage should be free.

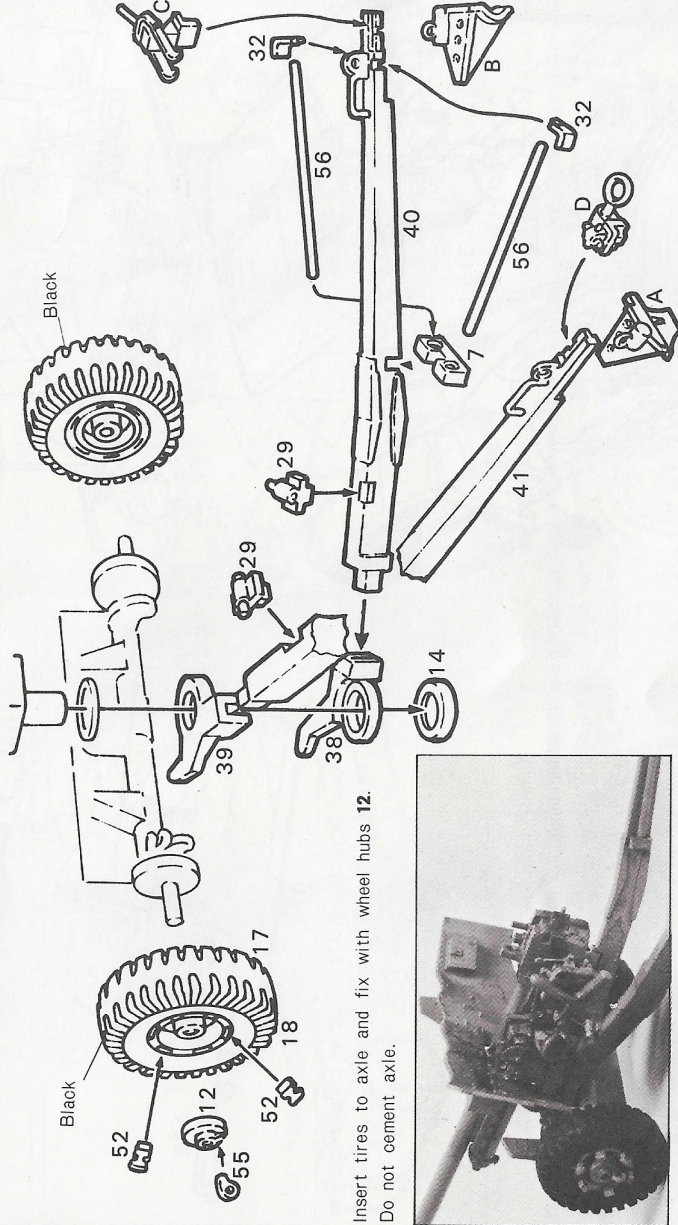

Insert tires to axle and fix with wheel hubs **12**. Do not cement axle.

13 WEATHERING PAINT FINISH

Coloring of Gun was basically British Sundry Yellow in North Africa, and Dark Green in European Theatre and in Pacific. As towing vehicles, some were camouflaged with irregular patterns.

Weathering must be done to give model genuine quality, but should not be overdone. First, paint model with lacquer paint. Then, with very thin enamel, paint for dirty appearance, dust or muddy effect for underside of vehicle and gun, also add sunburned effect on upper-side of model, etc.

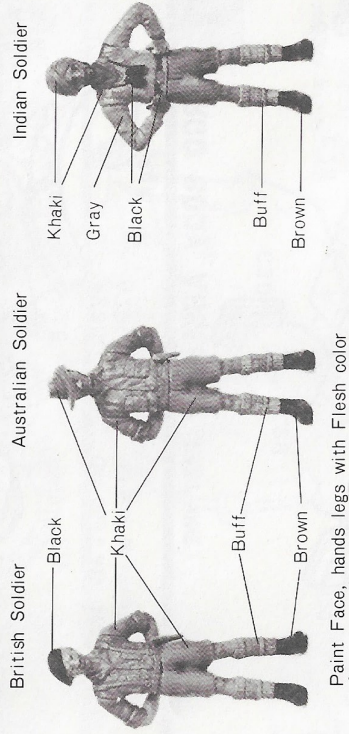

British Soldier

Australian Soldier

Indian Soldier

Black

Khaki

Black

Gray

Khaki

Black

Buff

Buff

Brown

Brown

Paint Face, hands legs with Flesh color

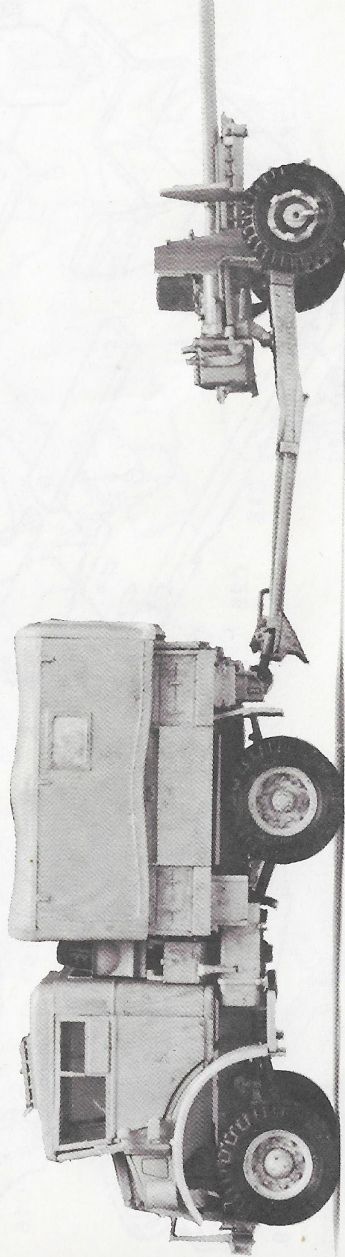

INDIAN ARMY USE, 10TH INDIAN DIVISION.

10th Indian Division was sent to Iran early in 1941, stationed in Bagdad which was occupied by the British 8th Army, and joined the North African Campaign. At the end of the African War it went to Cyprus, then moved to the Italian front in the spring of 1944. Vehicles were painted a Sand color overall, but some were camouflaged as in British and Canadian use.

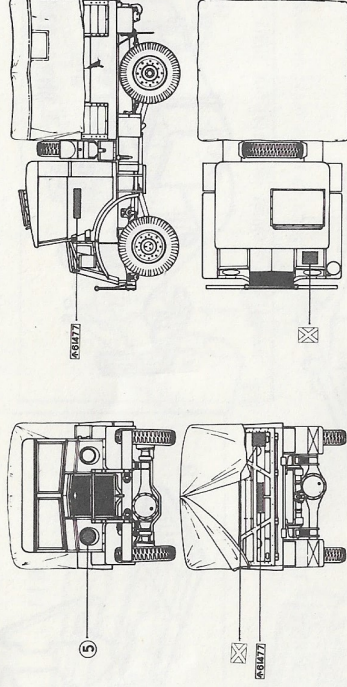
**AUSTRALIAN ARMY USE
9TH AUSTRALIAN DIVISION, 20TH ANTI-TANK BATTALION**

Joined British 8th Army, fought in North Africa, and returned to homeland in 1943. Reassembled and sent to New Guinea, painted Sand overall in North Africa and Dark Green in New Guinea. Again, some were camouflaged and some were marked for Air identification as shown in Decal.

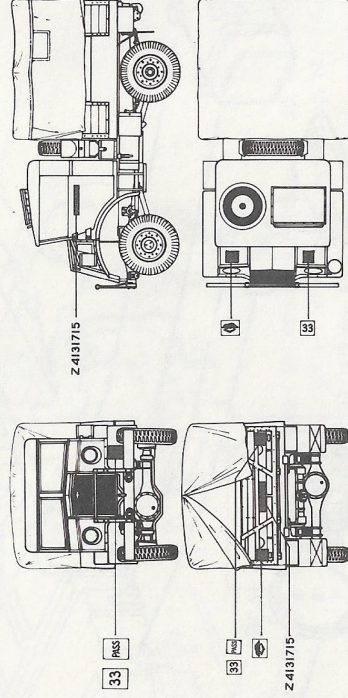
**BRITISH ARMY USE****21ST TANK BRIGADE, ANTI-TANK REGIMENT, 1ST COMPANY.**

Went to North Africa early in 1943, joined the battle of Tunisia, and served in the North African Campaign until surrender of Italian Forces. Then moved to Italian front, fought with Canadian Forces. Basically painted Sand color overall, also camouflaged with Charcoal Gray (Black 9 + Gray 1) or Dark Green. Some had White Stripes painted on each edge of front Fenders and front Bumper.

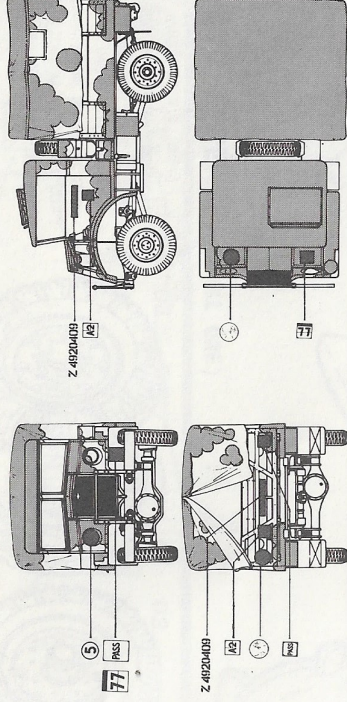
**CANADIAN ARMY USE****5TH CANADIAN ARMoured DIVISION,
12TH INFANTRY BATTALION, 2ND ARTILLERY COMPANY, HEADQUARTERS**

Landed in Naples in 1943, joined 1st Canadian Army; fought to break out of the Gothic line; moved to Holland in early 1945; served until the end of War in North Western Europe. Basically painted Dark Green overall and mostly camouflaged with Charcoal Gray as shown.

