

**AIRFIX**  
CONSTRUCTION KIT

**1/72 SCALE MODEL CONSTRUCTION KIT**

## **VICKERS-ARMSTRONGS WELLINGTON BIII**

The Wellington, affectionately known as the "Wimpey," was the standard Royal Air Force night bomber from 1939 until late in the war, and was built in larger numbers than any other British bomber, 11,450 being produced.

By no means a new aircraft at the outbreak of war—it was designed in 1933—the Wellington had a performance and capacity which was unsurpassed until the four-engined heavy bombers began operations in 1942. Wellingtons of Bomber Command went into action the day after the declaration of war, taking part in the memorable raid on the German Fleet in the Kiel Canal, later they took part in the first thousand bomber raids.

In addition to being used by R.A.F. Bomber Command in the offensive against the Reich, Wellingtons were used in large numbers in the Mediterranean theatre, both for bombing and torpedo dropping; in India for raids on Burma; and at home for mine laying and Coastal Command duties. Later in the war the Wellington was still being used in large numbers as an advanced trainer.

A notable feature of the Wellington was the geodetic construction, a system of metal strips taking the form of trellis work. This, together with the fabric covering, made the aircraft quicker to produce, and easier to maintain, than the conventional form of construction.

This particular aircraft is a BIII Wellington, the most widely produced of all the variants, and was operated by No. 75, Royal New Zealand Air Force Squadron.

The Wellington BIII was powered by two 1,380 h.p. Bristol Hercules II engines, giving a maximum speed of 263 m.p.h. and a range of 2,500 miles. Maximum bomb load was 4,000 lb. and defensive armament consisted of eight machine guns, two in the nose turret, four in the tail, and two hand-operated amidships.

Wing span was 86 ft. 2 in. and length 61 ft. 0 in.

# INSTRUCTIONS

PAINT ALL DETAILS AND LET DRY BEFORE ASSEMBLING (SEE SECTION 4)  
N.B. FOR PAINTING USE "AIRFIX" PAINTS, FOR FIXING USE "AIRFIX" POLYSTYRENE CEMENT

# 1

## FUSELAGE, WING & TAIL ASSEMBLY WITH CREW

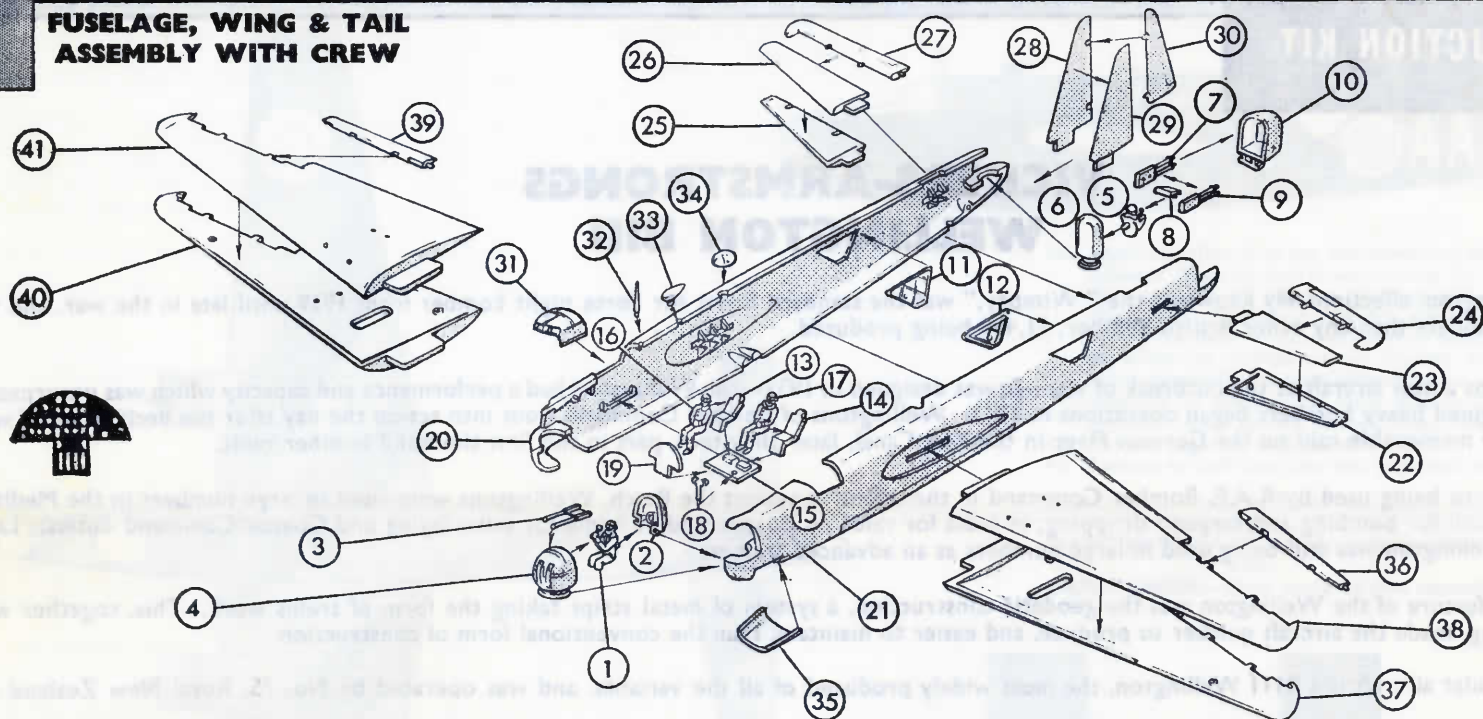

It is recommended that the instructions and exploded view are studied before commencing assembly. If it is wished to paint internal details such as crew, turret or cockpit interiors, this should be done before assembly.

1. Cement front gunner into turret rear (1 & 2).
2. Locate guns on to gunner's hands but do not cement (3).
3. Insert guns through rear of turret transparency, then cement transparency on to turret rear (4).
4. Cement rear gunner into turret back (5 & 6).
5. Locate and cement centre piece between port and starboard pairs of guns and allow to dry (7, 8 & 9).
6. When dry locate guns on gunner, pass through transparency, and cement transparency to turret rear (10).
7. Insert beam windows into inside of locations and cement in place, applying cement to edges of windows only (11 & 12).
8. Locate and cement seats to fuselage floor (13, 14 & 15).
9. Cement pilot and second crew member to seats (16 & 17).
10. Locate and cement in position control column (18).
11. Cut out and cement printed instrument detail to instrument panel, and cement panel into starboard fuselage half, in front of cockpit (19 & 20).
12. Locate and cement floor assembly into port fuselage half (21).

13. Place the gun turrets in the locating rings in the port fuselage half, then cement together the two fuselage halves **ENSURING NO CEMENT COMES INTO CONTACT WITH THE TURRETS**.
14. Cement together upper and lower halves of port tailplane (22 & 23).
15. Cement port elevator into locations, after selecting the desired elevator position (24).
16. Locate and cement tailplane to fuselage.
17. Repeat this procedure for starboard tailplane and elevator (25, 26 & 27).
18. Cement together both halves of fin (28 & 29).
19. Cement rudder into locating holes, and set at desired angle (30).
20. Cement cockpit canopy in place, applying cement carefully to edges of canopy (31).
21. Locate and cement in position antenna and direction finding loop (32 & 33).
22. Carefully cement astro dome over body opening (34).
23. Cement bomb aimer's panel in place beneath nose (35).
24. Lay port aileron in lower half of wing, and cement on upper wing half, **ENSURING NO CEMENT COMES INTO CONTACT WITH MOVING AILERON**, locate and cement wing into fuselage (36, 37 & 38).
25. Repeat this procedure for starboard wing (39, 40 & 41).

## 2

## ENGINE ASSEMBLY

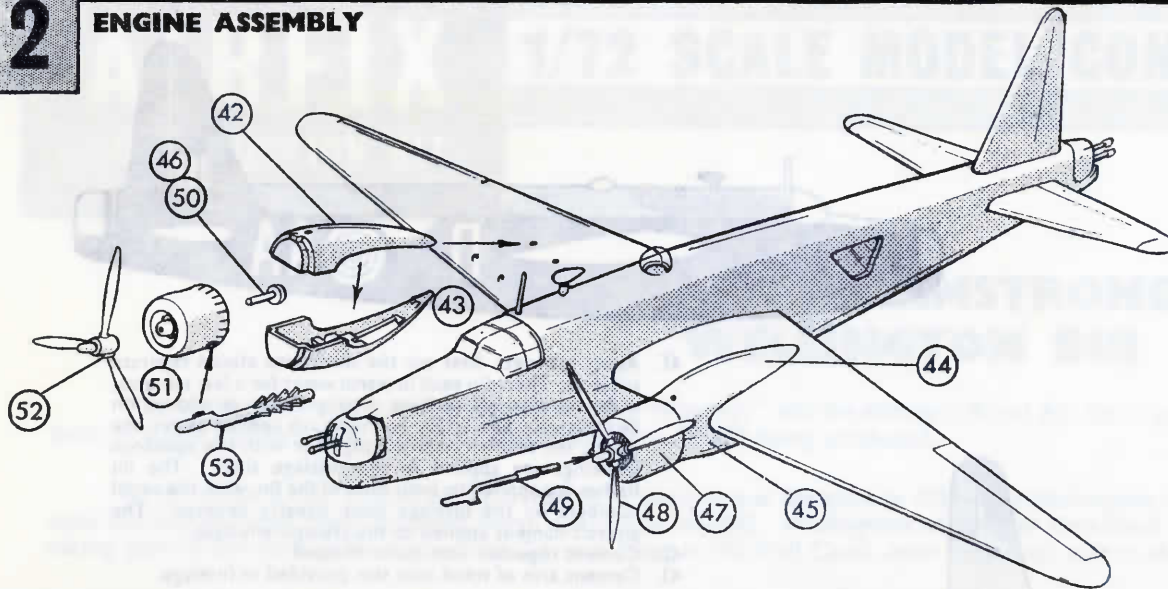

26. Locate and cement upper half of starboard nacelle to wing, and cement lower half in place beneath it (42 & 43).
27. Similarly locate and cement port nacelle halves (44 & 45).
28. Insert propeller pin through rear of cowling and cement into rear of propeller, ensuring no cement comes into contact with cowling (46, 47 & 48).
29. Locate and cement exhaust into cowling (N.B.—ensuring the locating slot for exhaust comes on inboard of cowling) (49).
30. Repeat the above procedure for starboard engine unit (50-53).
31. Cement completed engine unit on to fronts of nacelles.

## 3

## UNDERCARRIAGE ASSEMBLY

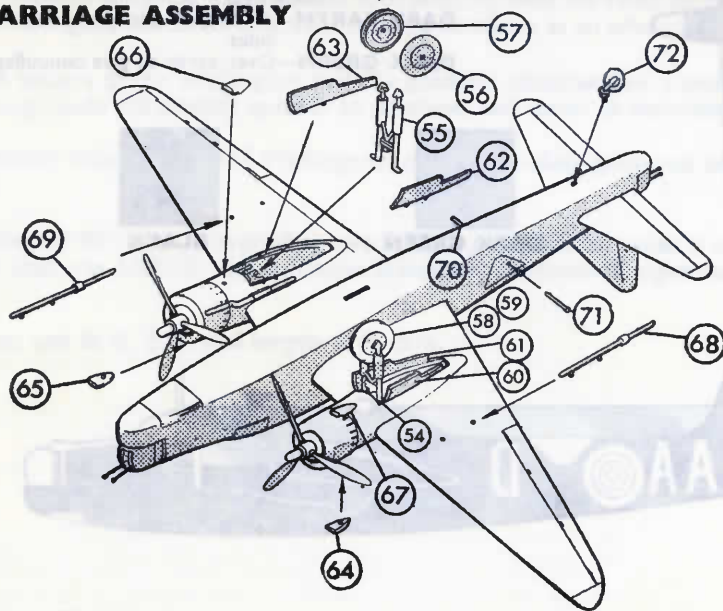

32. Press together the tops of the undercarriage legs, and spring into the locations in nacelle sides (54 & 55).
33. Cement together wheel halves and press into bearings on undercarriage legs (56-59). The desired undercarriage position should now be selected.
34. For a model with completely retracted undercarriage the undercarriage is swung right back and the wheel doors fixed in the closed position.
35. For a model with working undercarriage the doors are fixed in the open position, the undercarriage then being free to pivot.
36. To fix in the down position the legs are cemented in place.
37. Locate and cement in position the wheel doors (60-63).
38. Locate and cement the air intakes to the engine nacelles, the longer intakes above and the shorter below the engines (64-67).
39. Cement the fuel jettison pipes into locations beneath lower wings (68 & 69).
40. Cement beam machine guns into beam windows and locate and cement tailwheel beneath rear fuselage (70, 71 & 72).

NOTE:—If it is wished to paint the model it should be done at this stage, using camouflage scheme overleaf.

## SUGGESTED COLOUR SCHEME.

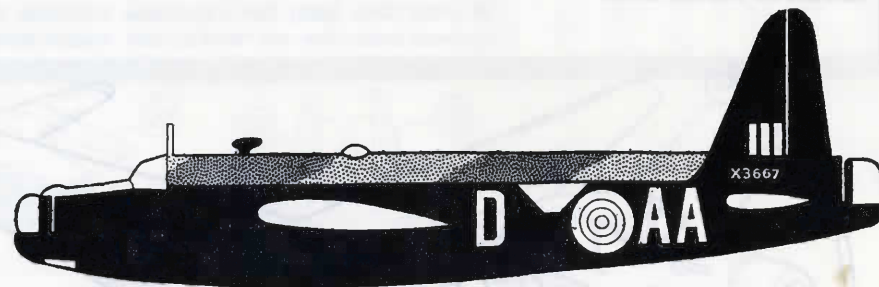
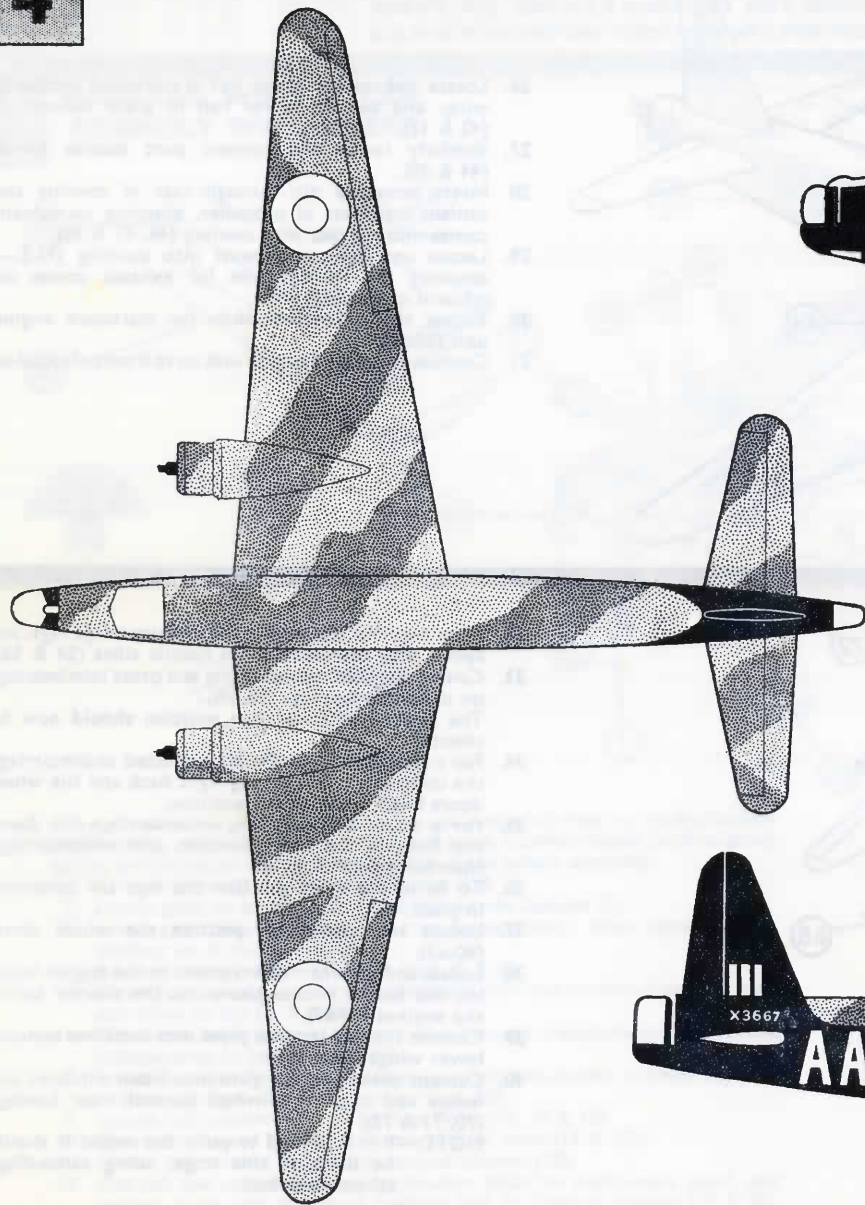

41. Apply transfers, first cut the sheet into eleven separate subjects. Then dip each in warm water for a few minutes, slide transfer off backing into position as shown on illustration. The larger roundels are applied above the wings, the smaller roundels together with the squadron markings are applied to the fuselage sides. The fin flashes are applied to both sides of the fin, with the serial numbers on the fuselage sides directly beneath. The aircraft name is applied to the transparent base.
42. Cement together both parts of stand.
43. Cement arm of stand into slot provided in fuselage.

**BLACK**—All undersurfaces and sides up to line of camouflage.

**DARK EARTH**—All upper surfaces down to black at sides.

**DARK GREEN**—Over earth to give camouflage effect.

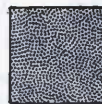

DARK GREEN



BLACK

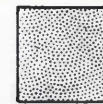

DARK EARTH

