



# M3A3 LIGHT TANK "STUART"

## 美國M3A3輕戰車"史都華"

After the breakout of WWII, the US Army came to realize the potential of tanks for rapid assault, therefore had started to develop new light tanks. In June 1940, attempts of adding thicker armour, idle wheels, as well as enhanced anti-aircraft weapons were made on the rivet-jointed M2A4 chassis, rendering it the M3 light tank. The whole design was finalized by July 1940.

M3A3 was the last modified version of the M3 family, which adapted inclined armour plates on its front as well as on both sides, also made full use of welding to enhance its structural strength. Its turret was also enlarged, adding a space for radio equipment at its rear. A gunner of former M3 tanks had to share the same hatch with the tank commander, whereas the M3A3 has separate hatches for its gunner. The main armament of M3A3 is a 37mm cannon, supplemented by three 7.62 machine guns, including one mounted coaxially with the main gun, one mounted forward, and one used as an anti-aircraft weapon. The prototype of this tank was completed in August 1942, and mass production had begun in 1943, some 3427 were built until October of the same year.

The successful turret design of M3A3 was also adapted by the M5A1, which was then under development. Since the better fuel-efficient M5A1 won the favour of the US Army, leaving the M3A3 with little chance to compete. Therefore 2433 M3A3s had been handed over to Allied countries including the Great Britain, China, and Free France under the Lend-Lease Act, saw intensive services in Western Europe, Italy, Burma, and the later Chinese civil war.

第二次世界大戦が勃発し、戦車の持つ機動性と攻撃力に気づいたアメリカ陸軍は、新しい軽戦車の開発に着手しました。1940年6月、リベット接合のM2A4戦車のシャーシに厚い装甲と接地式の誘導輪、強化された対空火器を装備し、M3軽戦車として全体的なデザインを1940年7月までに完了させました。M3A3軽戦車は、M3系軽戦車の最後の改修バージョンで、車体正面と両側面に傾斜した装甲板を備え、また全体に溶接を採り入れることで構造的な強度を増しています。砲塔も、無線装置のためのスペースを設けるために大型化されました。以前のM3軽戦車では、砲手は車長と一つのハッチを共用してはなりませんでしたが、新砲塔では砲手のためのハッチが設けられました。この優れた砲塔デザインは、その後に開発された、M5A1軽戦車にも採用されることとなります。主砲には37mm砲を備え、副武装として、主砲と同軸に一丁、車体前面に一丁、対空用として一丁、計三丁の7.62mm機銃が装備されました。M3A3軽戦車の試作型は、1942年8月に完成し、生産が1943年から開始され、同年10月までに、およそ3427輛が製造されました。その後、後継車のM5A1軽戦車が、良好な燃料効率を示したため、アメリカ陸軍は、軽戦車の主力をM3A3からM5A1へと移行することを決定します。しかし、2433輛のM3A3軽戦車は、レンドリースにより、イギリス、中国、自由フランス軍等の連合軍へ引き渡され、西部ヨーロッパ、イタリア、ビルマ等で集中的に使用されて活躍し、後の中国での国共内戦でも、その姿を見ることができました。

## M3A3輕戰車

第二次世界大戰爆發後，美國陸軍體認到戰車的快速攻擊作用，於是便開始研製和裝備新的輕戰車。1940年6月，美軍在採用裝甲板鉚接結構的M2A4輕戰車的基礎上，採取增加裝甲厚度，動力系統則以加裝惰輪、改進防空武器等措施，完成設計了M3輕型坦克，並於1940年7月完成原型。

M3A3是M3系列輕型坦克最後一種改進型，車體前部和兩側裝甲板改為傾斜佈置，而且大量採用焊接結構來增加車身的強度。砲塔同時加大，並在後方增加可容納無線電的空間，在早期的M3輕戰車砲手需要從車長出入口進出，而在M3A3上也有了自己的出入口，主要武器為37毫米火炮，安裝在砲塔中央，輔助武器為3挺7.62mm機槍，包括：1挺同軸機槍、1挺前置機槍和1挺防空機槍。該戰車1942年8月完成原型，1943年投入生產，產期至同年十月，共生產了3427輛。

M3A3砲塔設計的成功，隨即被導入正在開發中的M5A1輕戰車上，由於M5A1在燃油消耗上較為經濟並大量裝備美軍，M3A3對美軍的重要性便大幅降低，其中的2433輛便透過租借的方式交給英國、中國及自由法國等同盟國軍隊，活躍於西歐、義大利、緬甸及稍後的中國內戰。

1943年5月中國駐印軍在印度藍伽姆組建了3個輕戰車營並在緬北胡岡谷地的攻擊中成功佔領了瓦魯班，大戰結束後由於滇緬公路上的橋樑無法負荷戰車的重量，這批M3A3便被留置在印度，隨後因內戰爆發M3A3便以海運方式運回國內參與了魯南戰役及徐蚌會戰。

### Illustration:圖示說明



### Method For Applying Decals:

1. Clean Model Surface With Wet Cloth.
2. Cut Out Of Decal Sheet And Dip Them In Water For 15 Seconds.
3. Place it on proper position on model.
4. Slide off base paper leaving decals On Model With Wet Finger Tip.
5. Move Decals To Exact Position, Push Out Excess Water Under Decal With Soft Cotton Cloth.
6. When Decals Get Dry Then Complete.

### 水貼紙使用說明:

1. 將模型表面擦乾淨
2. 將貼紙剪下泡入清水中約15秒
3. 將泡濕之貼紙取出置於欲貼處旁
4. 用指尖輕推貼紙表面使其滑出底紙
5. 將貼紙調整至適當位置並輕擦拭水份
6. 待其自然乾燥後即完成

### Color list: 塗料表

Color	Brand	GSI Creos (Gunze Sangyo)			Humbrol	Revell	Life Color
		Hobby Color	Mr. Color	Mr. Color Spray			
Olive drab(2)	橄欖綠	H-78	C-38	J-38	66	46	UA106
Khaki green	卡其綠	H-80	C-54				
Flat white	消光白	H-11	C-62	J-62	34	05	LC01
Steel	黑鐵	H-18	C-28	J-28	53	91	LC76
Tire black	輪胎黑	H-77	C-137		85	302	
Bright blue	寶藍	H-15	C-65	J-65	14	51	LC60
Red brown	紅褐	H-47	C-41	J-41	160	383	
Red	紅	H-3	C-3	J-3	19	31	LC56

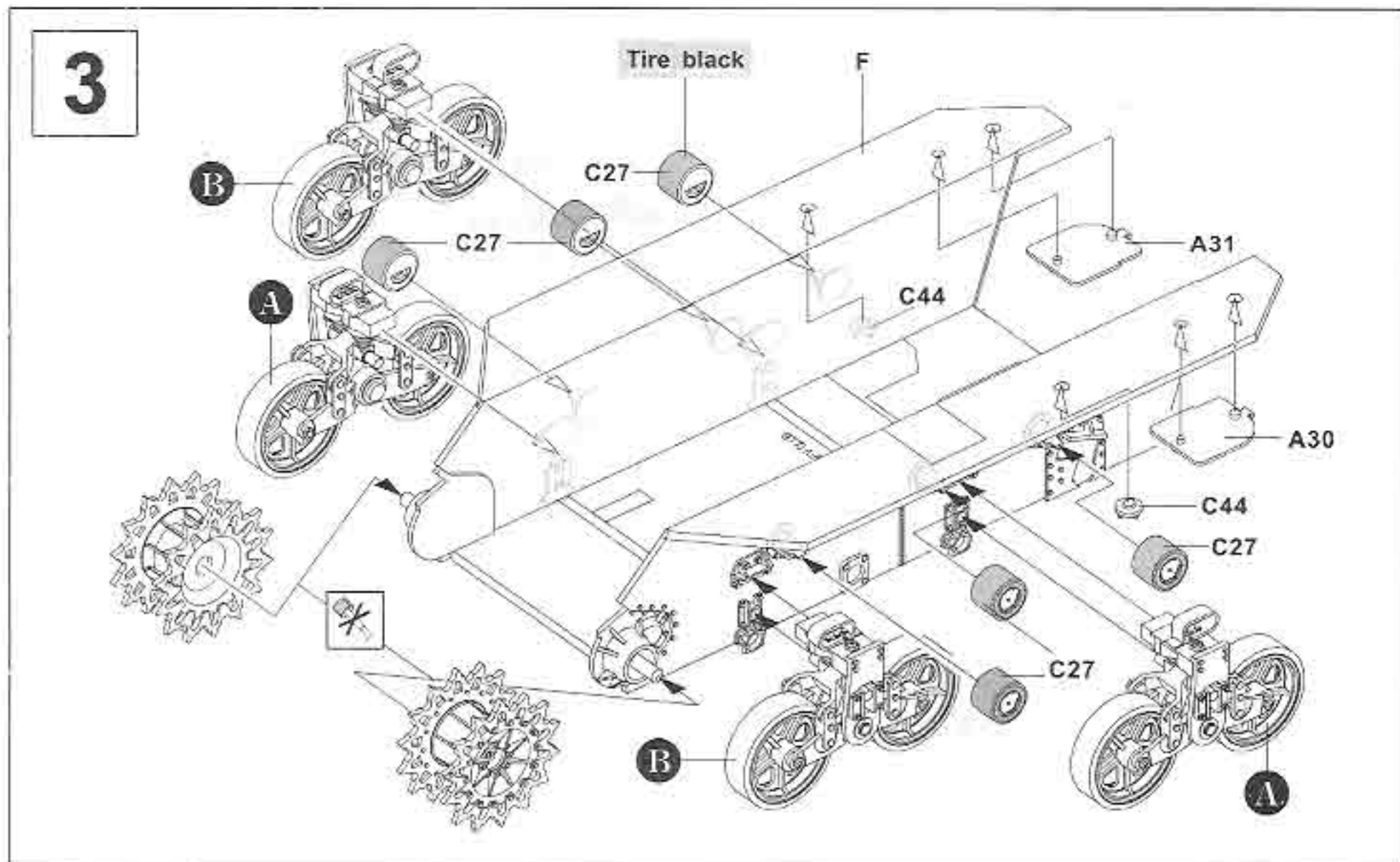
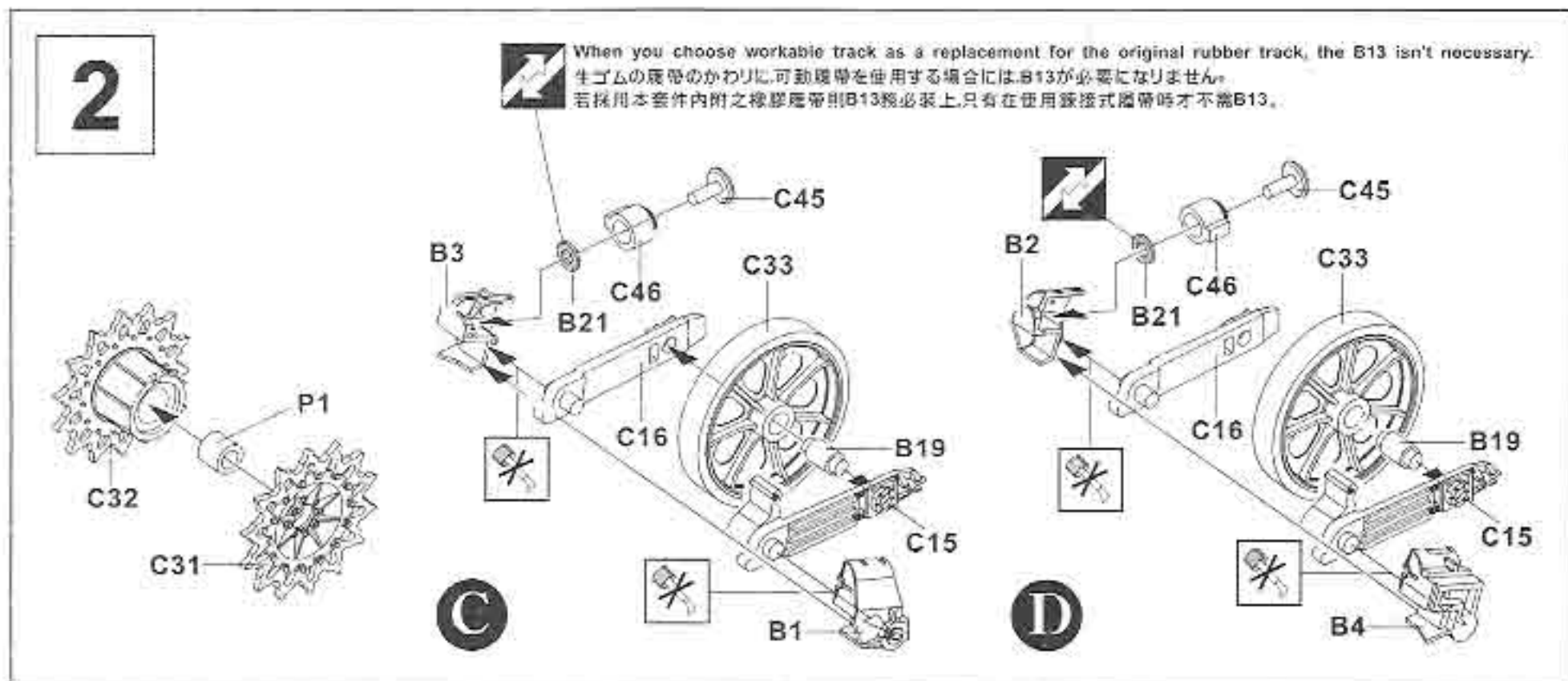
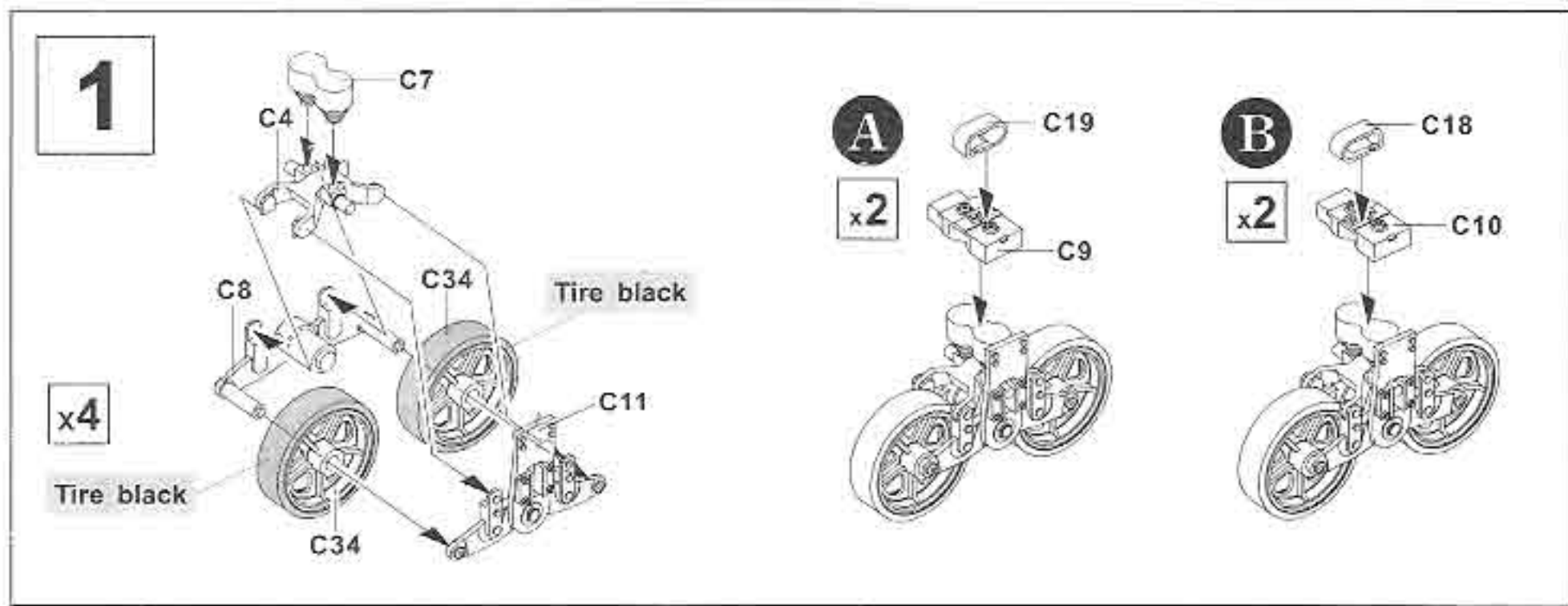

4

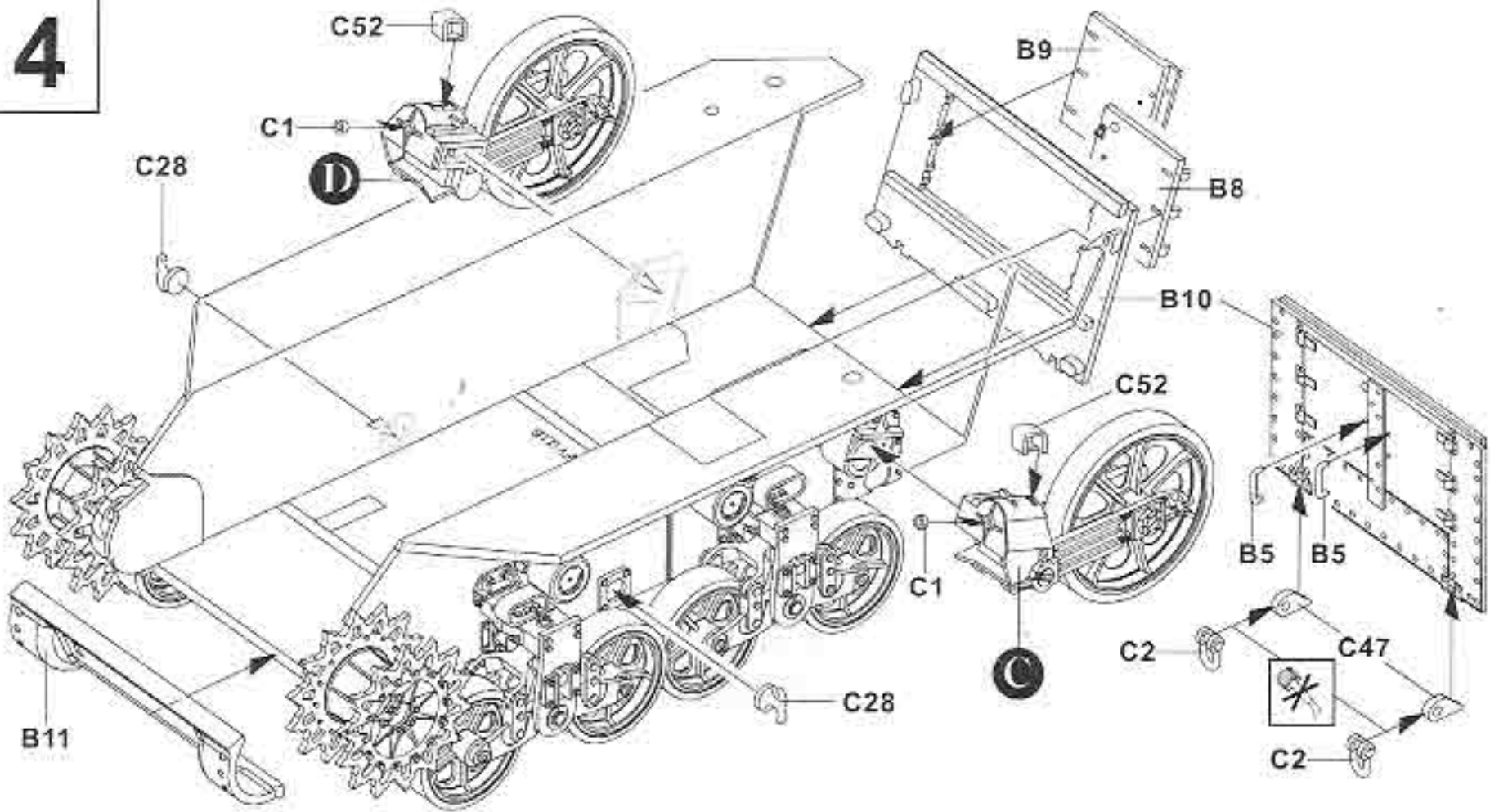

5

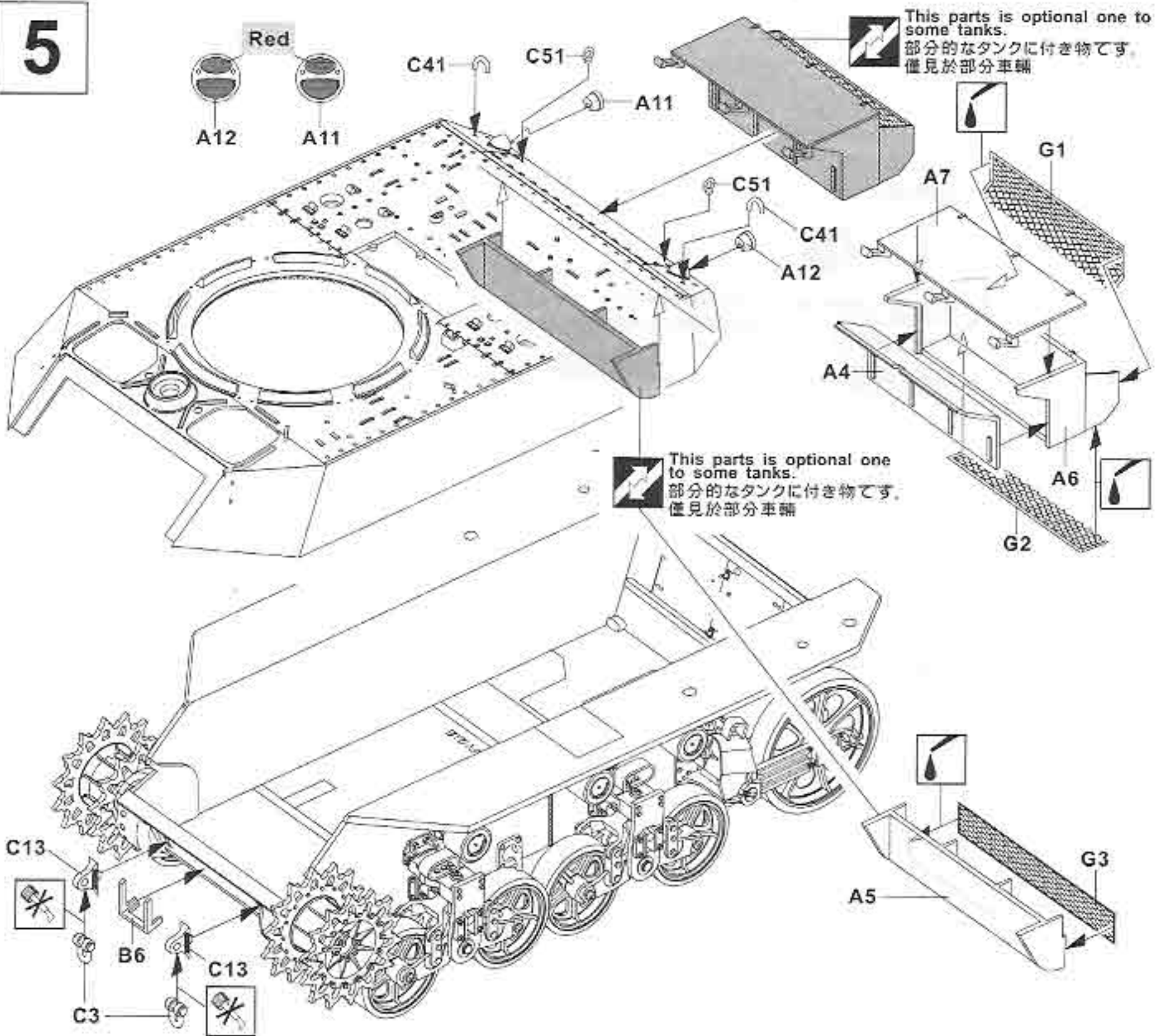

6

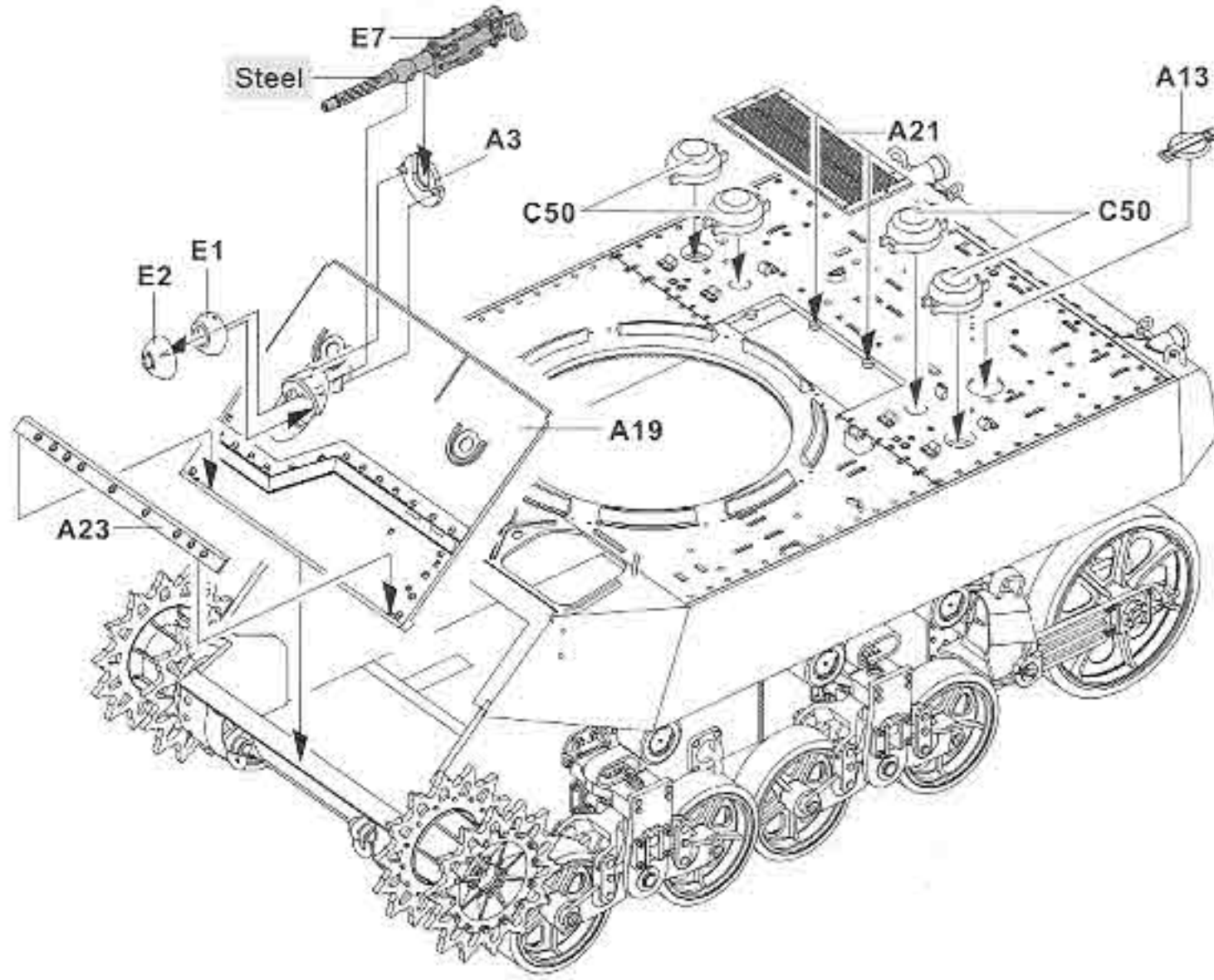

7

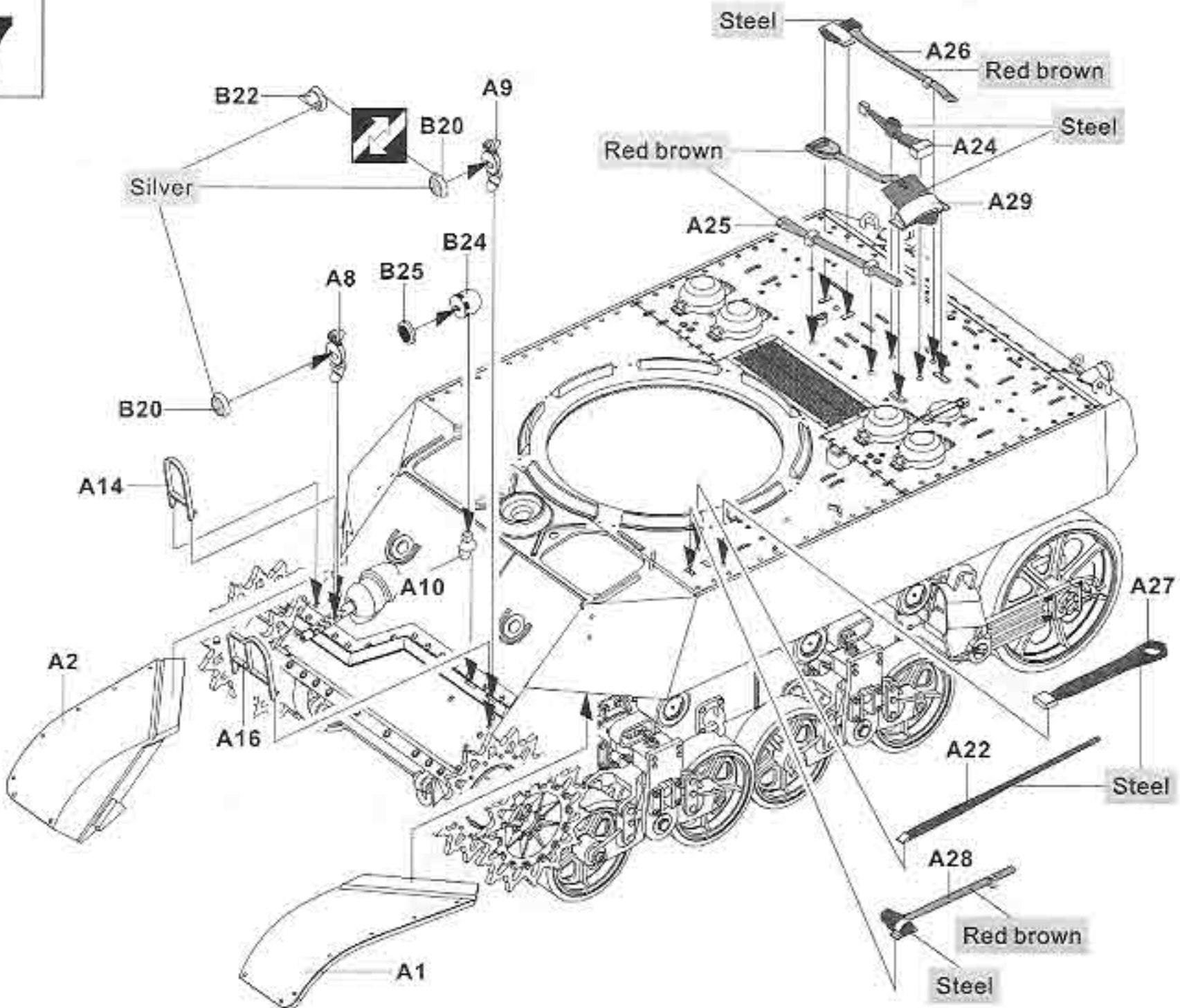

8

E

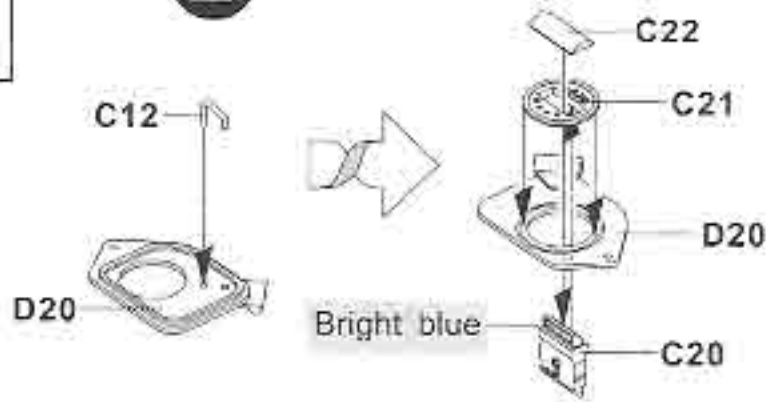

F

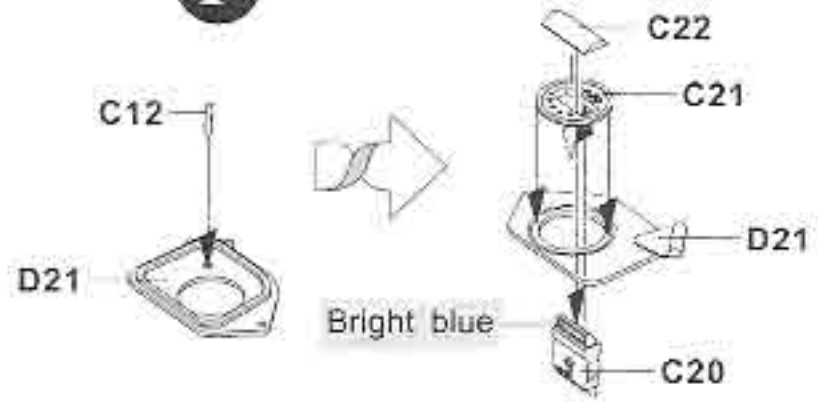

9

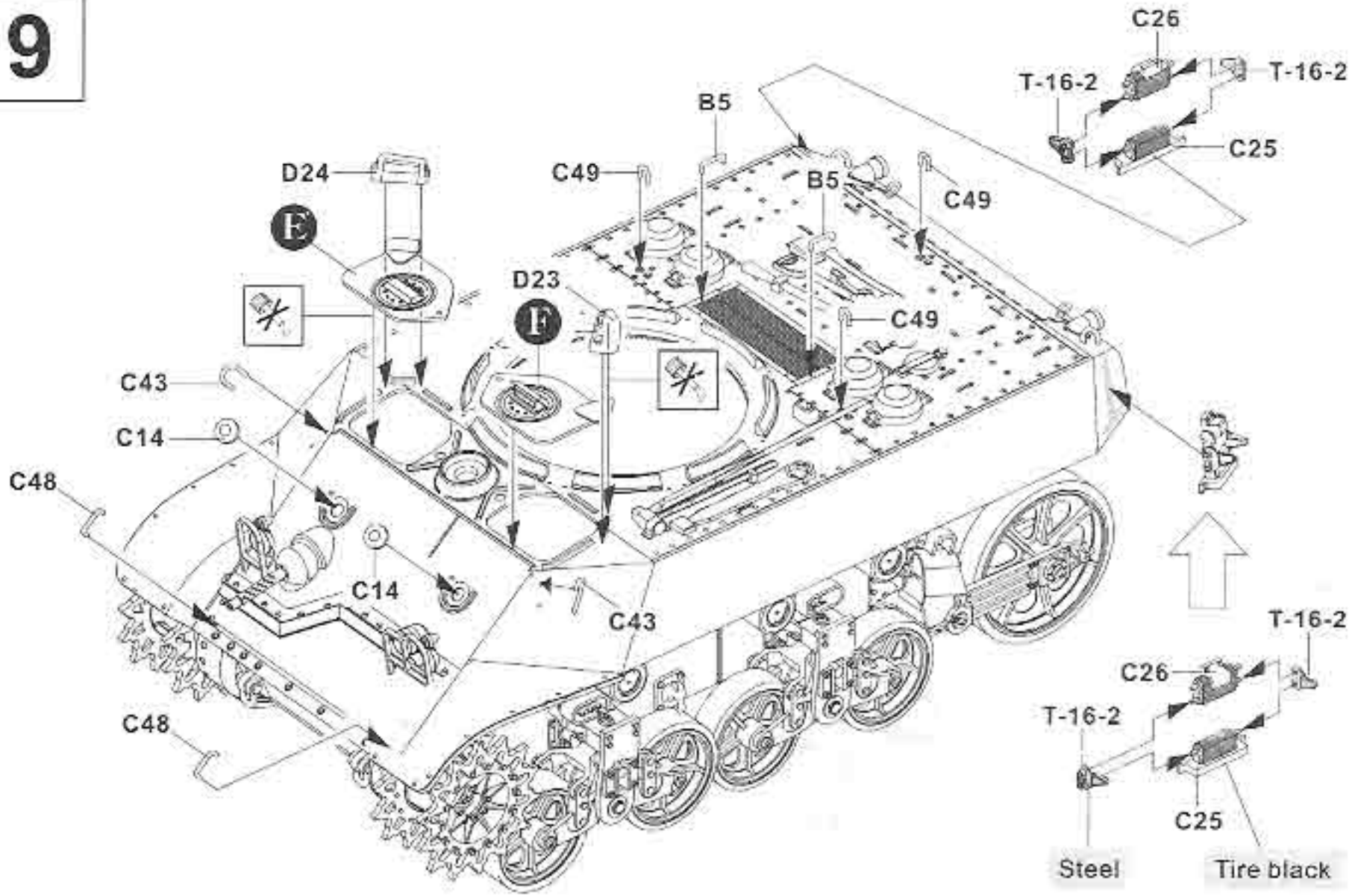

10

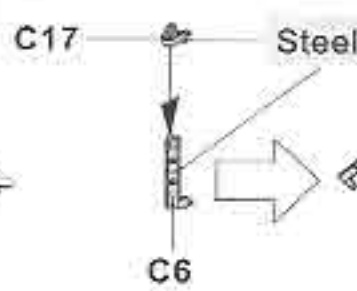
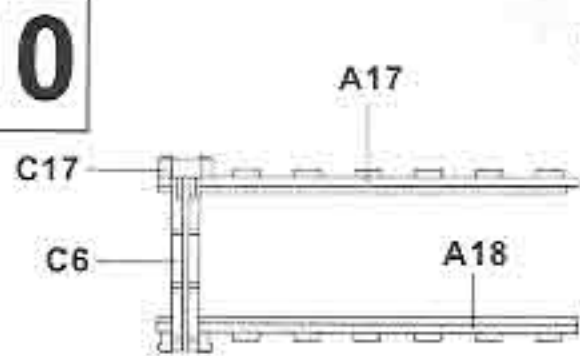

Great Britain and Yugoslavia version.  
 イギリス、ユーゴスラビア仕様。  
 大英國協與南斯拉夫式樣。

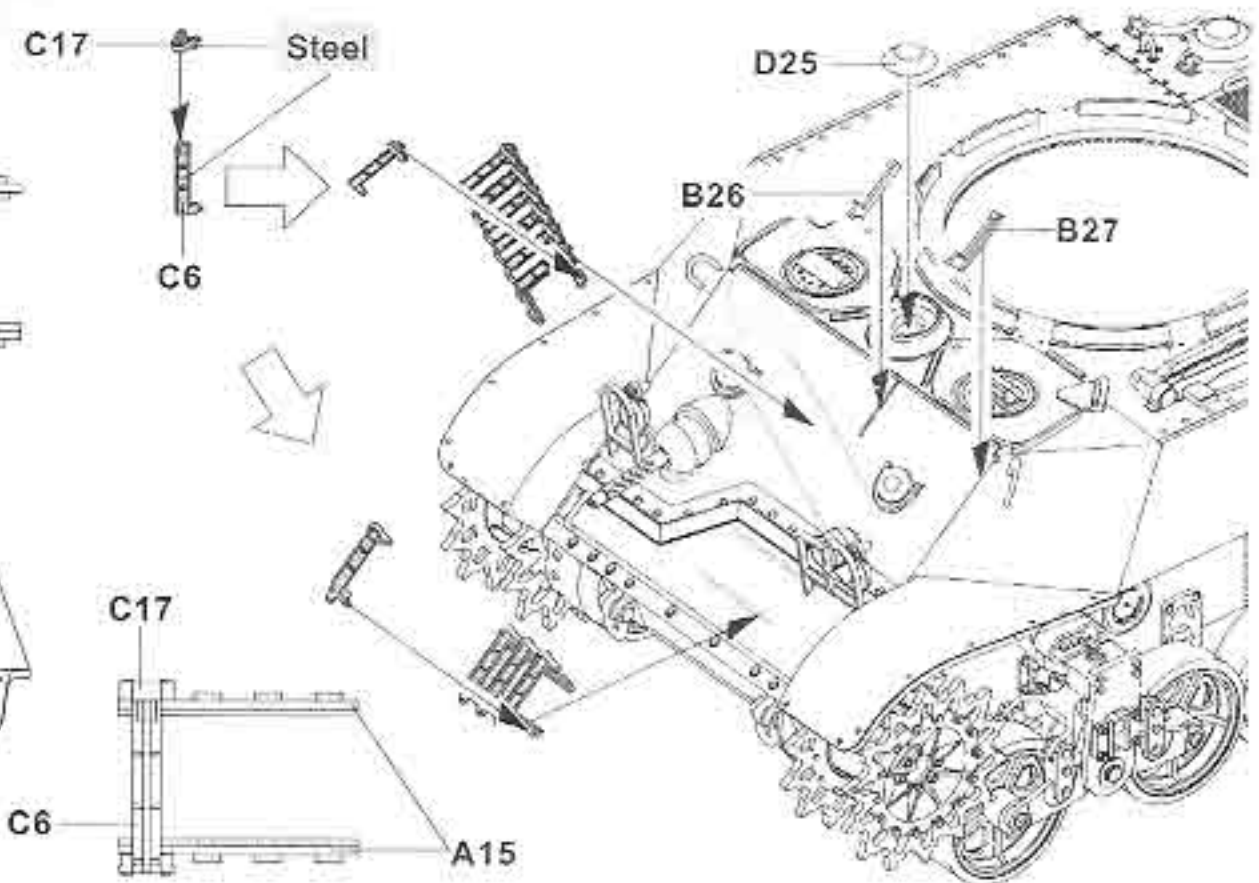
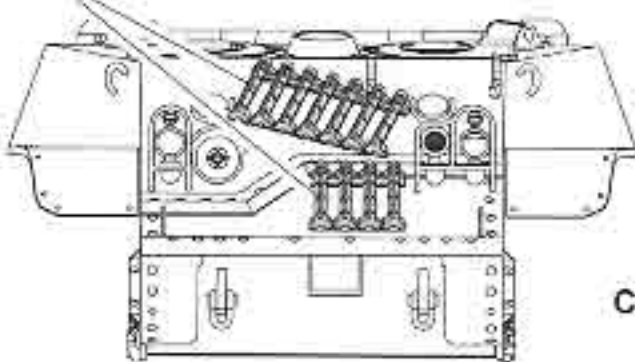

# 11

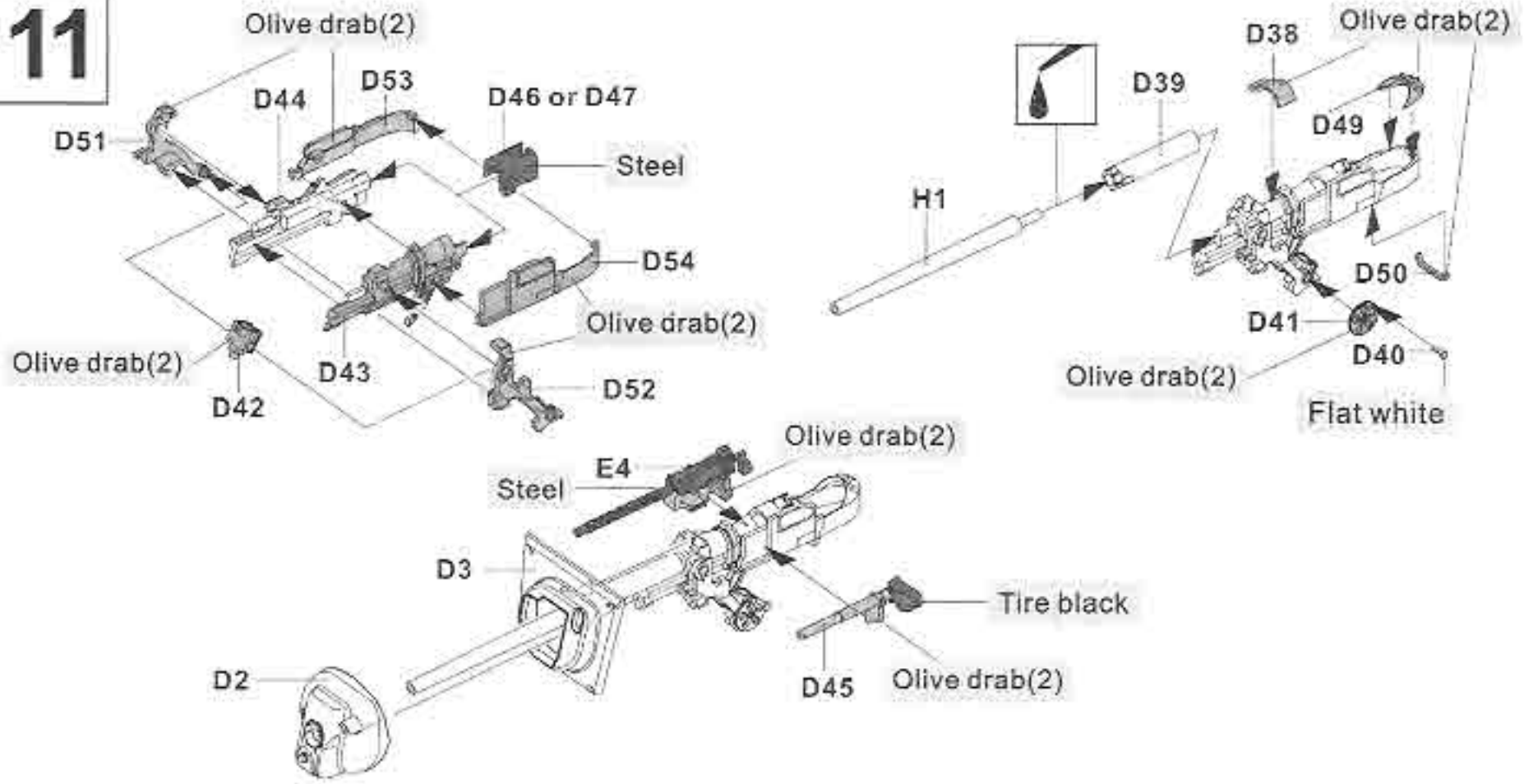

# 12

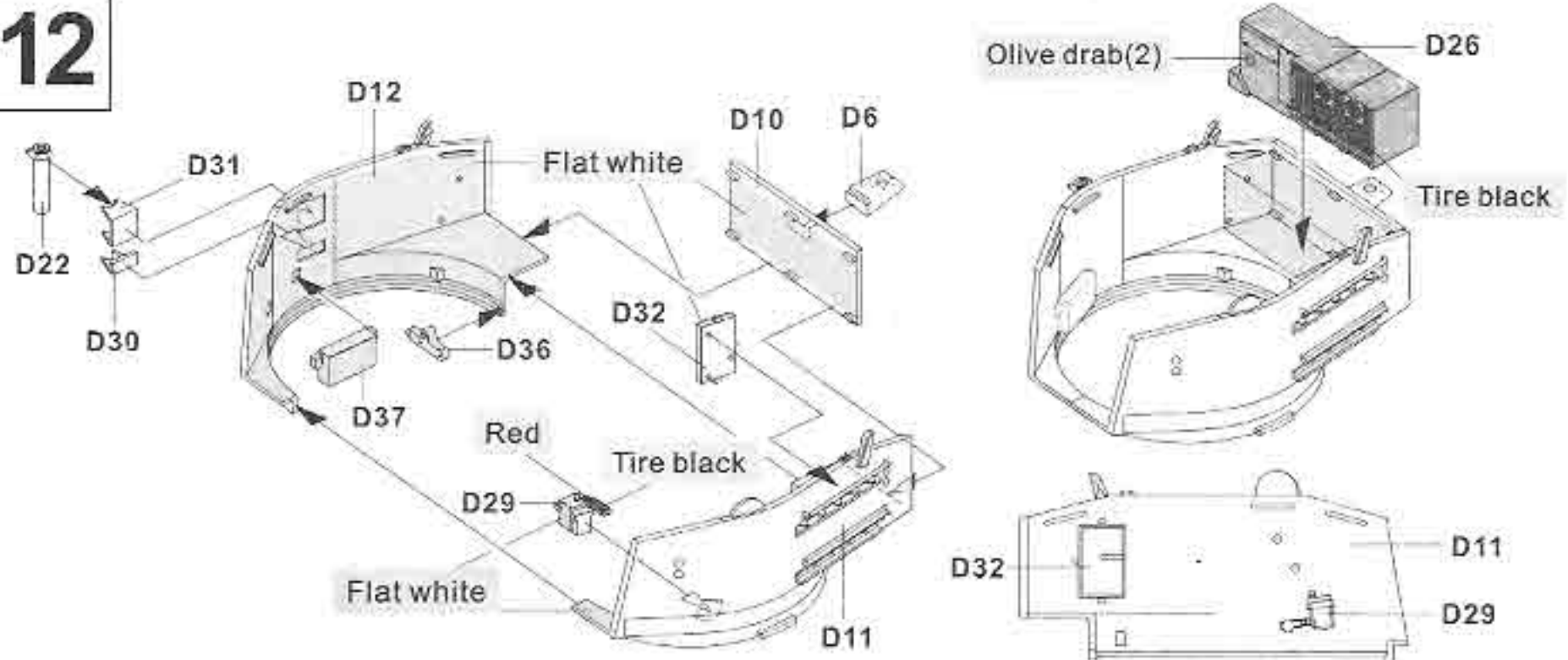

# 13

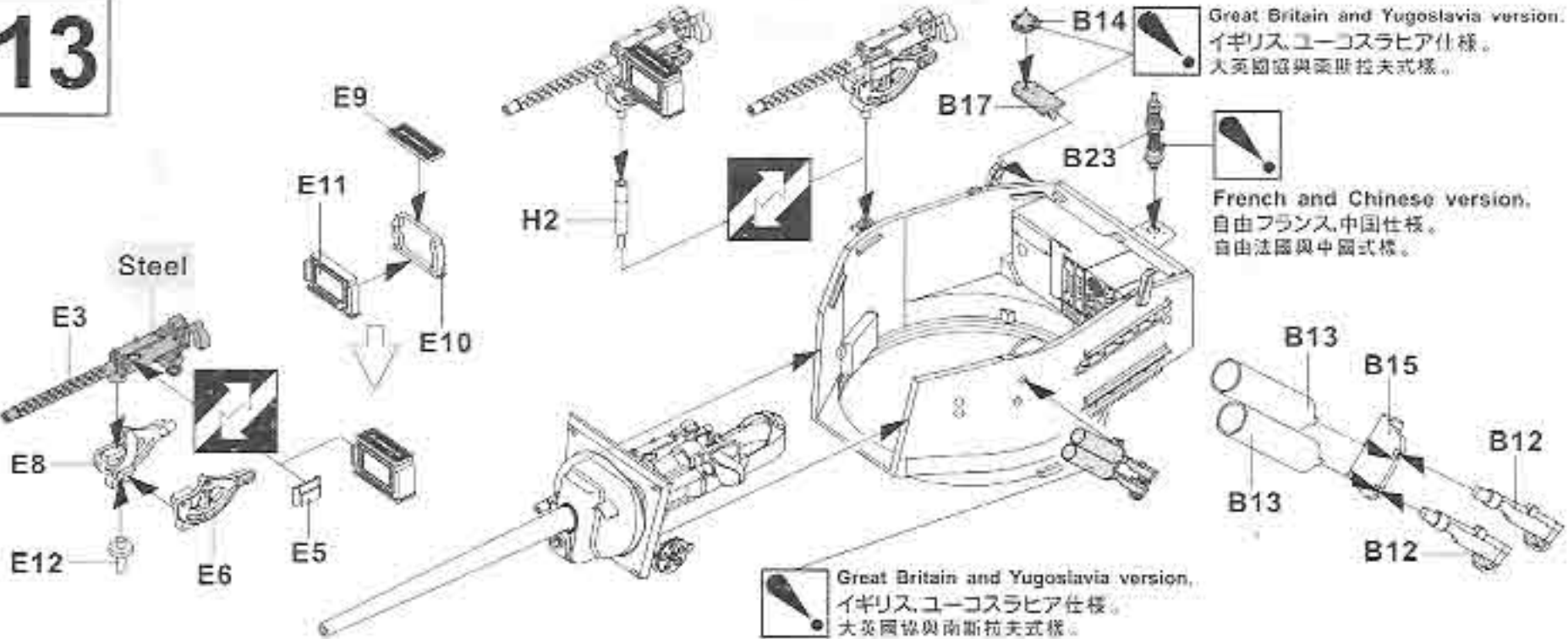

14

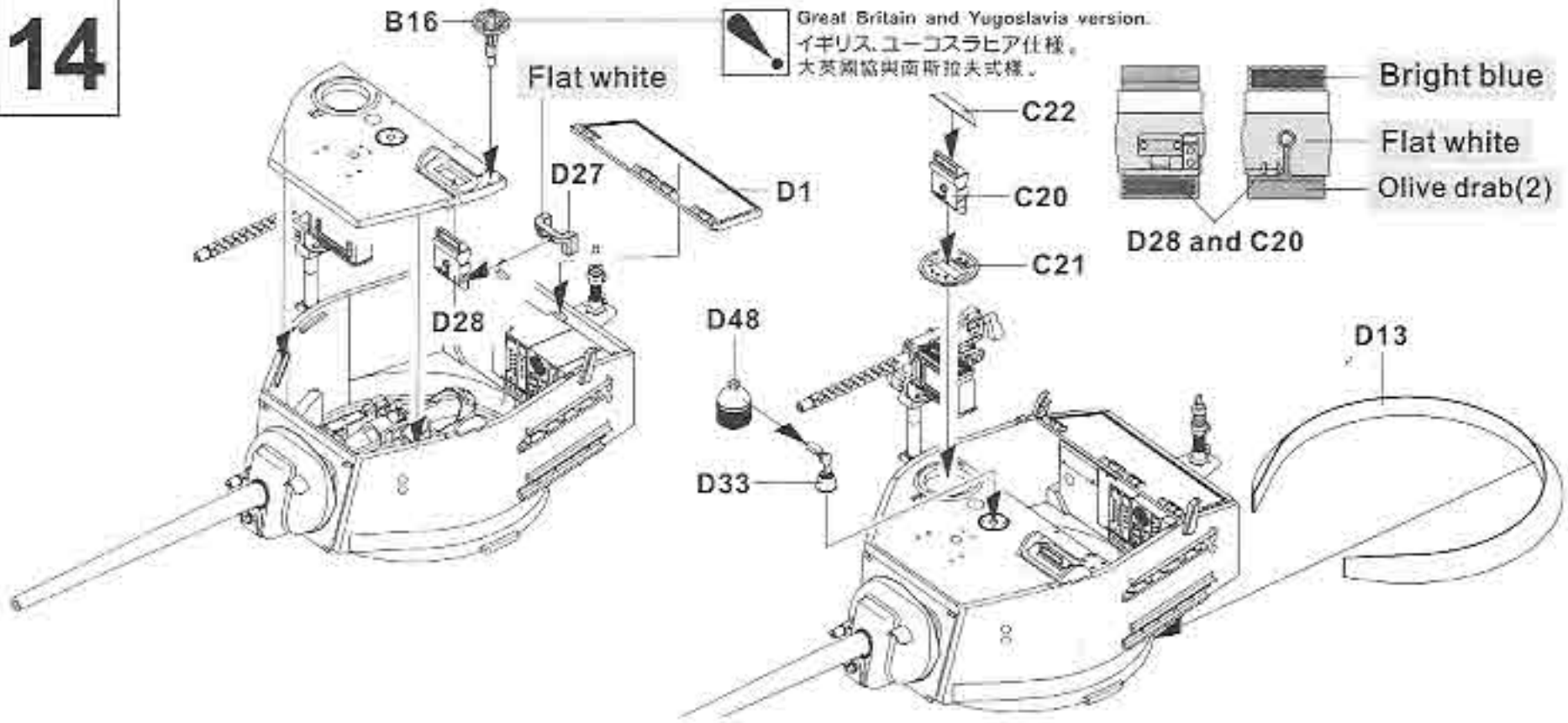

15

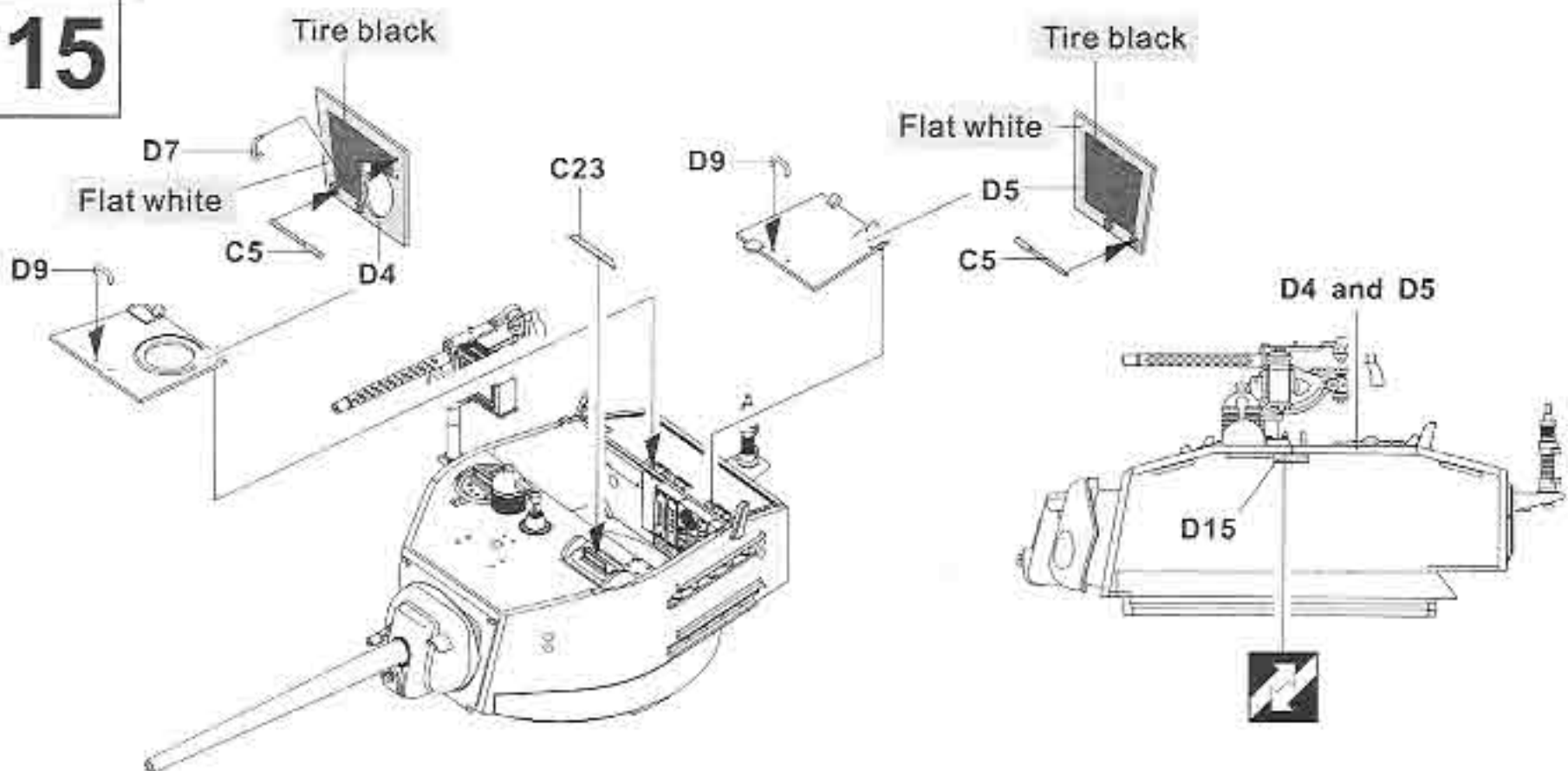

16

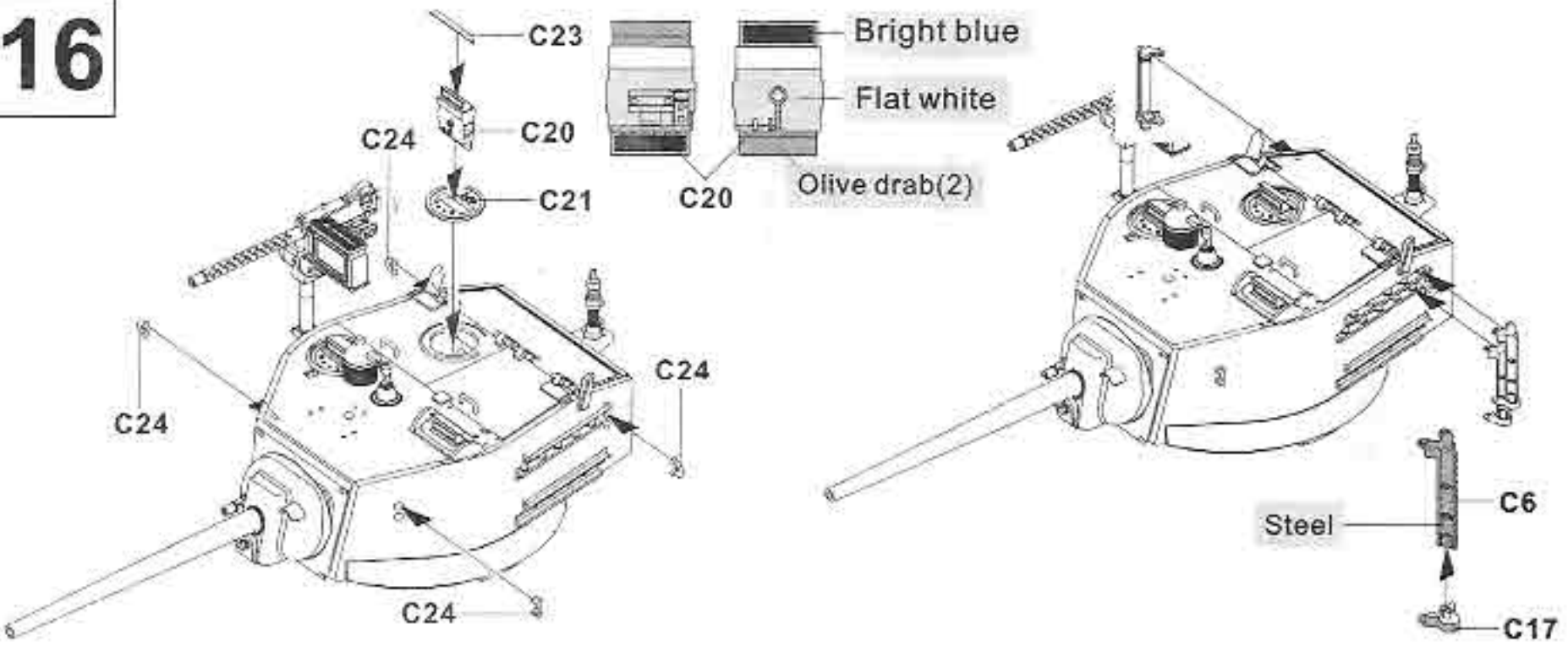



17

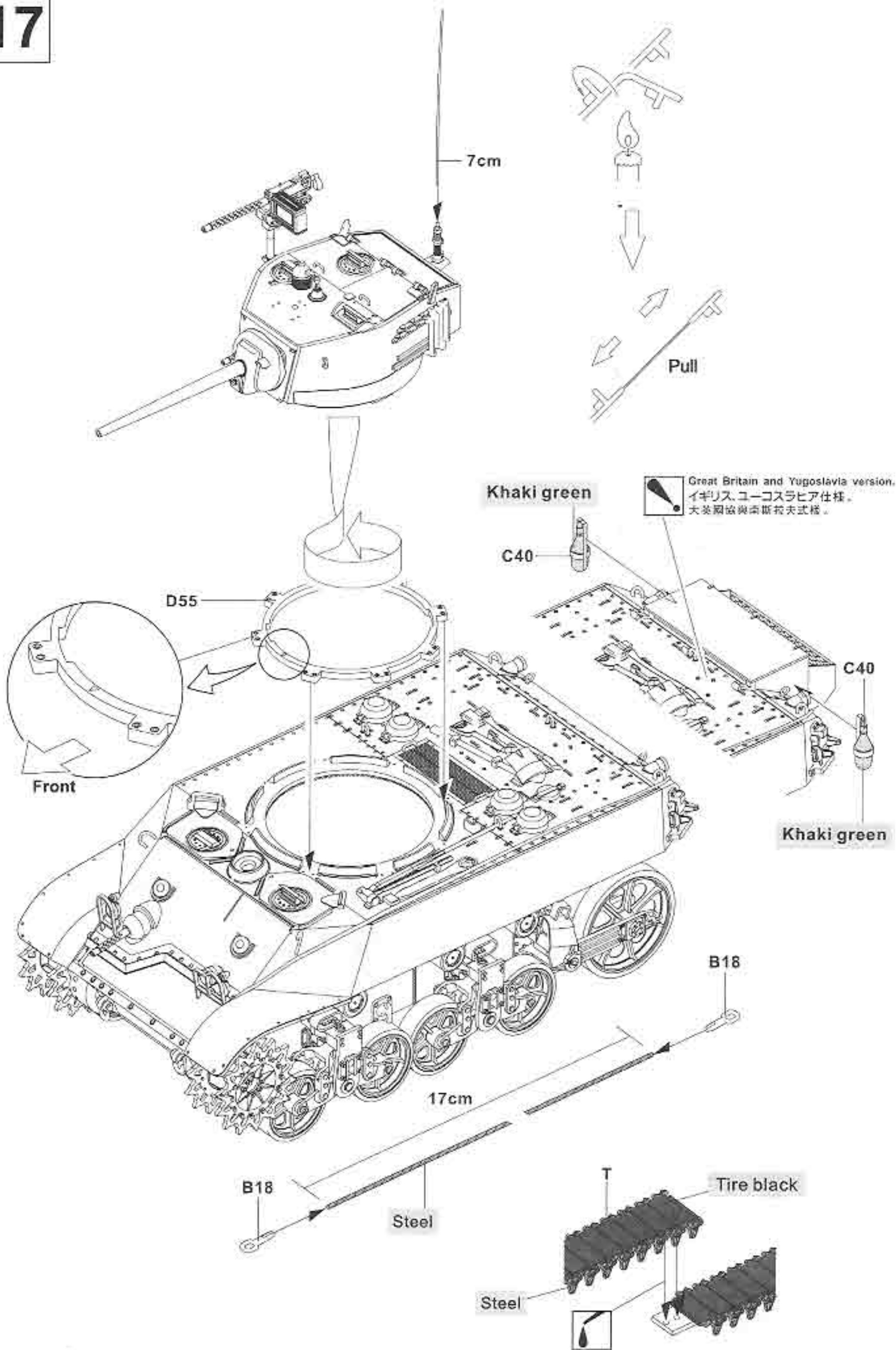

**A**

Free French, 1st Morocco Cavalry, 2nd Amd. Division.

自由法國, 第二裝甲師第1摩洛哥騎兵旅

 Body Color: Olive drab(2)

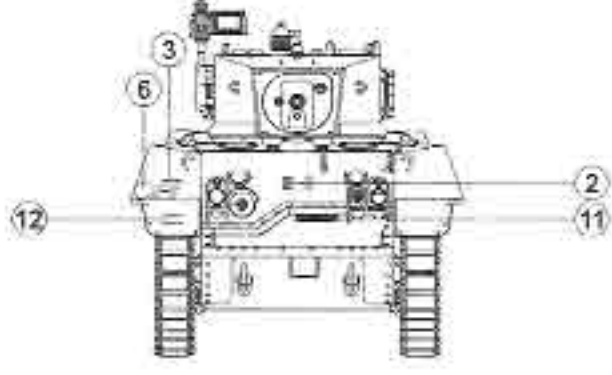
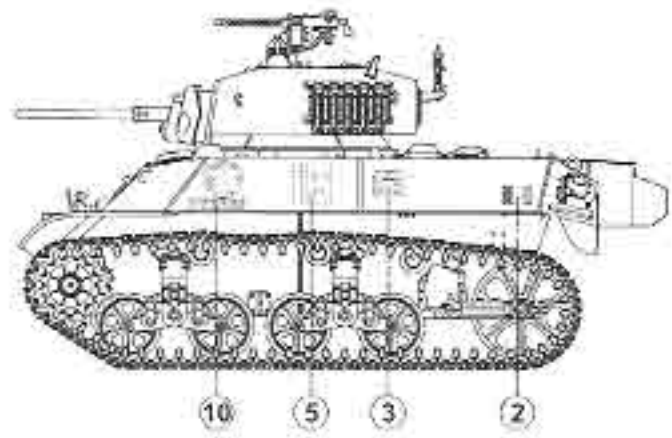
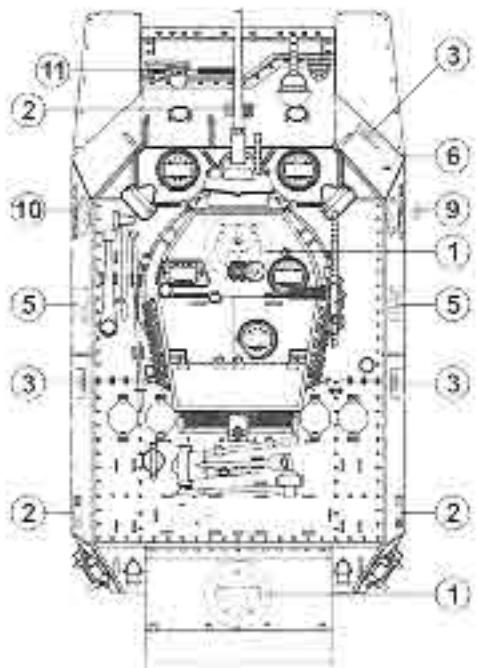

**B**

3th Company 1st Battalion 1st Chinese Provisional Tank Group. Burma, 1945.

中國緬甸遠征軍, 第一臨時戰車群第一營第三連, 1945年緬甸

 Body Color: Olive drab(2)

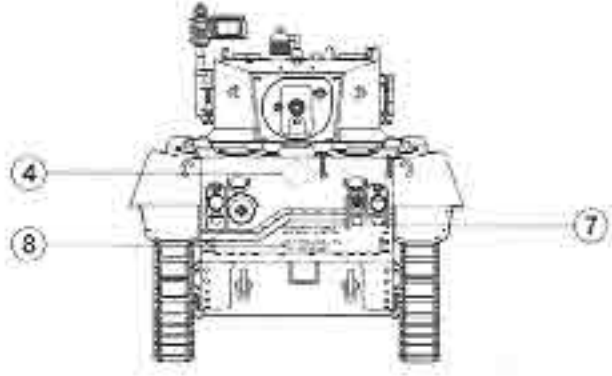
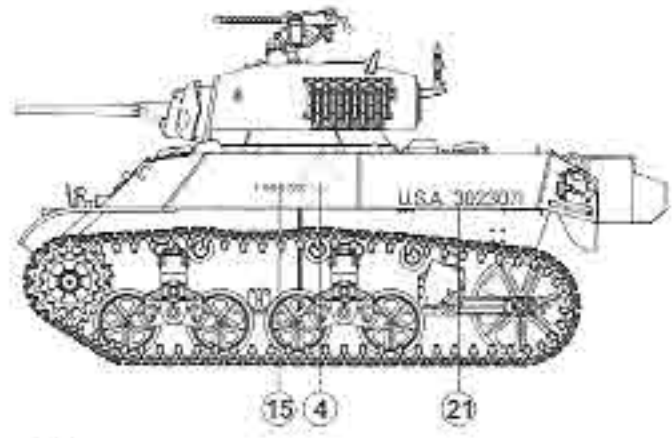
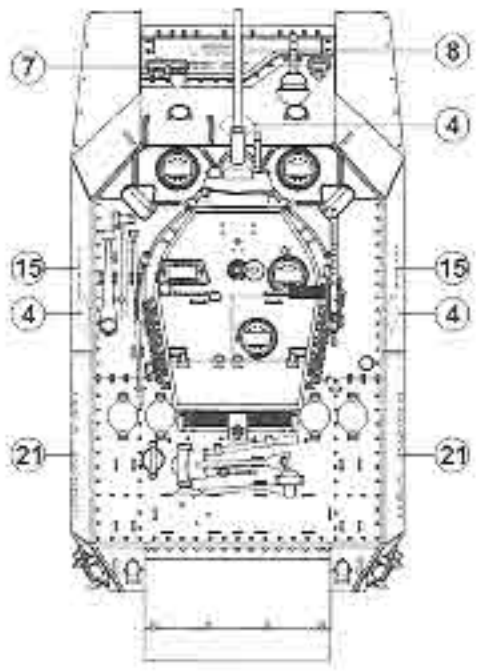

**C**

Yugoslavia, 1st Tank Brigade in July 1944.

南斯拉夫第一裝甲旅, 1944年7月

 Body Color: Olive drab(2)

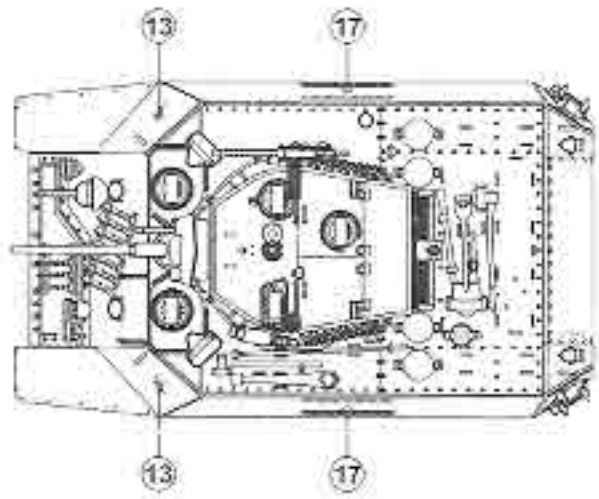
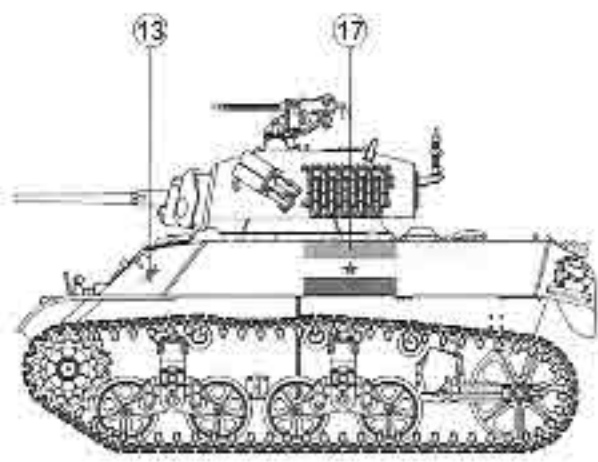

**D** Free French, 5th Amd. Division. 1944  
 自由法國, 第五裝甲師, 1944年

 Body Color: Olive drab(2)

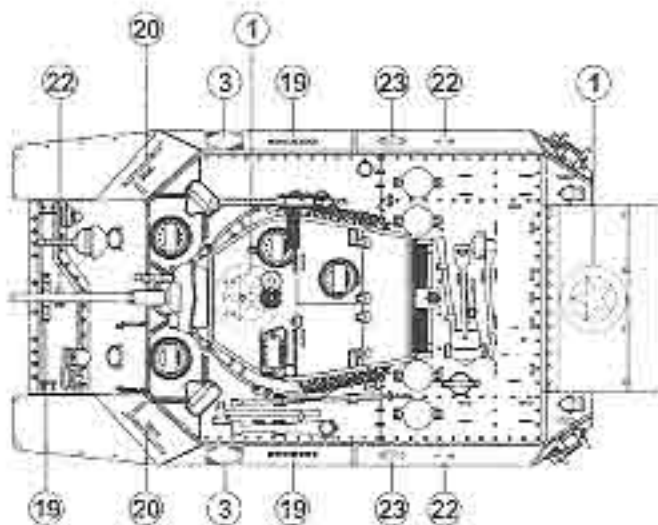
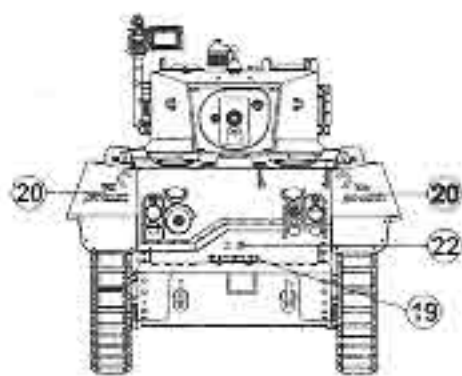
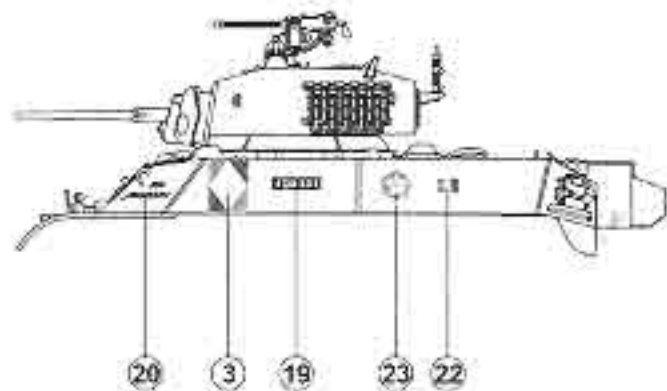

**E** British, 5th Royal Tank Regiment, 22nd Amd Brigade. June 1944  
 英國第22裝甲旅第五皇家戰車團, 1944年6月

 Body Color: Olive drab(2)

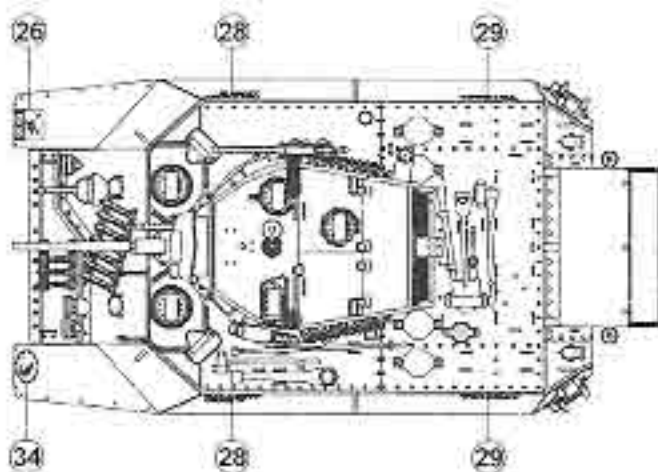
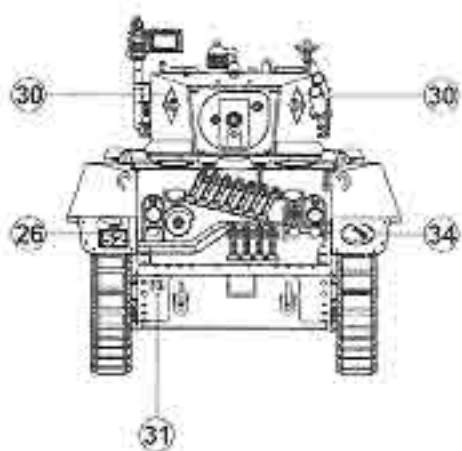
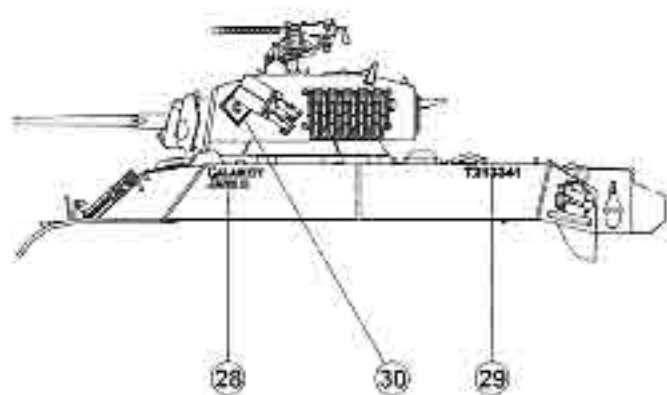

**F** British, 22nd Amd Brigade, 7th Amd. Division. June 1944  
 英國第七裝甲師第22裝甲旅, 1944年6月

 Body Color: Olive drab(2)

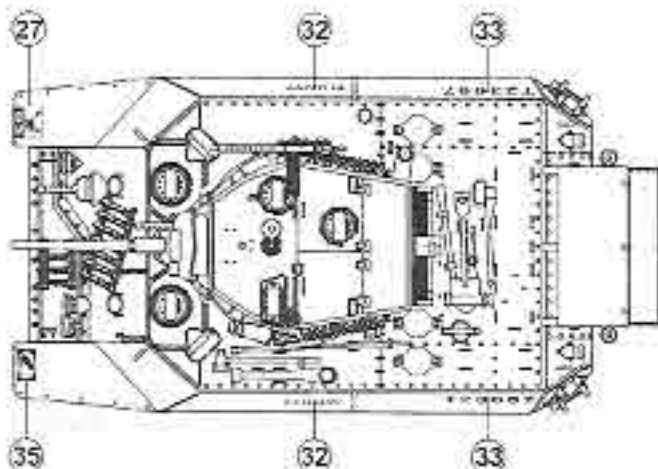
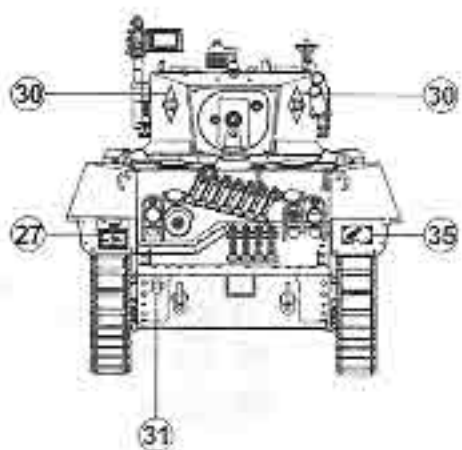
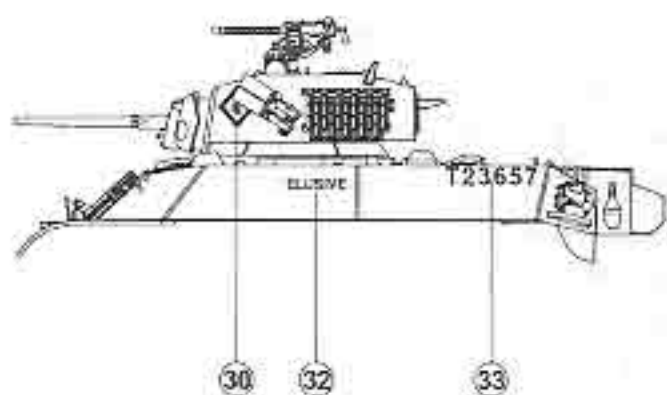

**G** 3th Company 3th Battalion 1st Chinese Provisional Tank Group. Burma, 1945.  
 中國緬甸遠征軍, 第一臨時戰車群第三營第三連, 1945年緬甸

 Body Color: Olive drab(2)

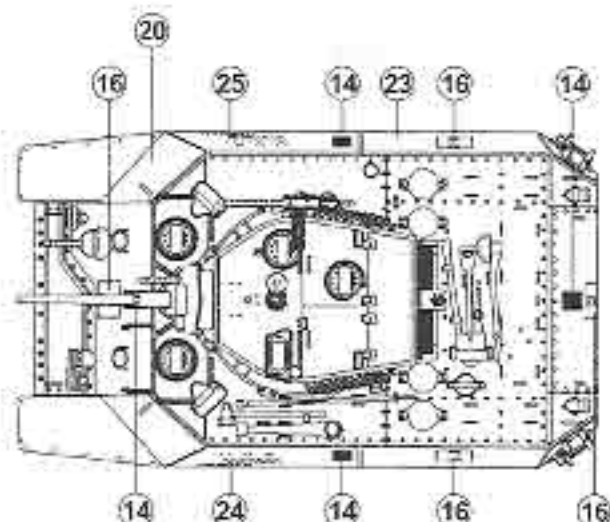
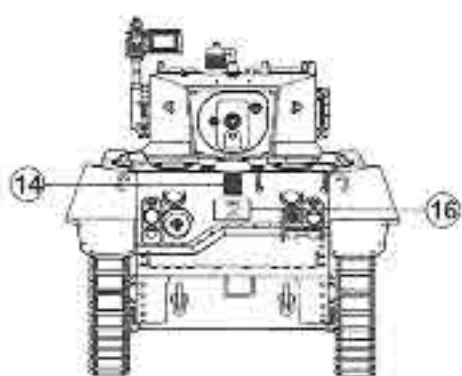

# PARTS LIST 零件表

Parts :

(A) ——— 1	(D) ——— 1	(G) ——— 1	(P) ——— 1
(B) ——— 1	(E) ——— 1	(H) ——— 1	(T) ——— 1
(C) ——— 2	(F) ——— 1	(J) ——— 1	(T16) ——— 1

Instructions:

If for some reason, you are not fully satisfied or have questions concerning our product; Please use the form provide, and send it to our nearest representative or mail it directly to our office.

We will deal with that A.S.A.P.

<b>AF 35053</b> Parts Replacement Form	
<input type="checkbox"/> A parts <input type="checkbox"/> B parts <input type="checkbox"/> C parts <input type="checkbox"/> D parts <input type="checkbox"/> E parts <input type="checkbox"/> F parts <input type="checkbox"/> G parts	<input type="checkbox"/> H parts <input type="checkbox"/> J parts <input type="checkbox"/> P parts <input type="checkbox"/> T parts <input type="checkbox"/> T16 parts
Reason for replacement:	<input type="checkbox"/> Missing <input type="checkbox"/> broken
Signature: _____	

限台灣地區使用 For Taiwanese use only!

總代理：戰鷹企業 客服部收 本公司將盡速為您處理  
請將本表與該部品相同金額之郵政匯票一同寄至

<b>AF 35053</b> 零件補充申請表	申請人 姓名 地址 電話 : : :
<input type="checkbox"/> A部品零件 ——— NT\$ 260 <input type="checkbox"/> B部品零件 ——— NT\$ 160 <input type="checkbox"/> C部品零件 ——— NT\$ 280 <input type="checkbox"/> D部品零件 ——— NT\$ 300 <input type="checkbox"/> E部品零件 ——— NT\$ 120 <input type="checkbox"/> F部品零件 ——— NT\$ 160 <input type="checkbox"/> G部品零件 ——— NT\$ 120 <input type="checkbox"/> H部品零件 ——— NT\$ 120 <input type="checkbox"/> J部品零件 ——— NT\$ 160 <input type="checkbox"/> P部品零件 ——— NT\$ 40 <input type="checkbox"/> T部品零件 ——— NT\$ 200 <input type="checkbox"/> T16 部品零件 ——— NT\$ 60	
(請填) 總計 NT\$ _____	
零件補充原因: (請於 <input type="checkbox"/> 打✓) . 原包裝即 <input type="checkbox"/> 遺失或 <input type="checkbox"/> 毀損 . . 製作途中 <input type="checkbox"/> 遺失或 <input type="checkbox"/> 毀損 . . <input type="checkbox"/> 補充多餘零件 . . 其他原因 _____	