

Leichte Zugkraftwagen 3t

GERMAN 3 TON HALF-TRACK (LATE VERSION)

**Sd.Kfz. 11
Einheitsfahrerhaus**

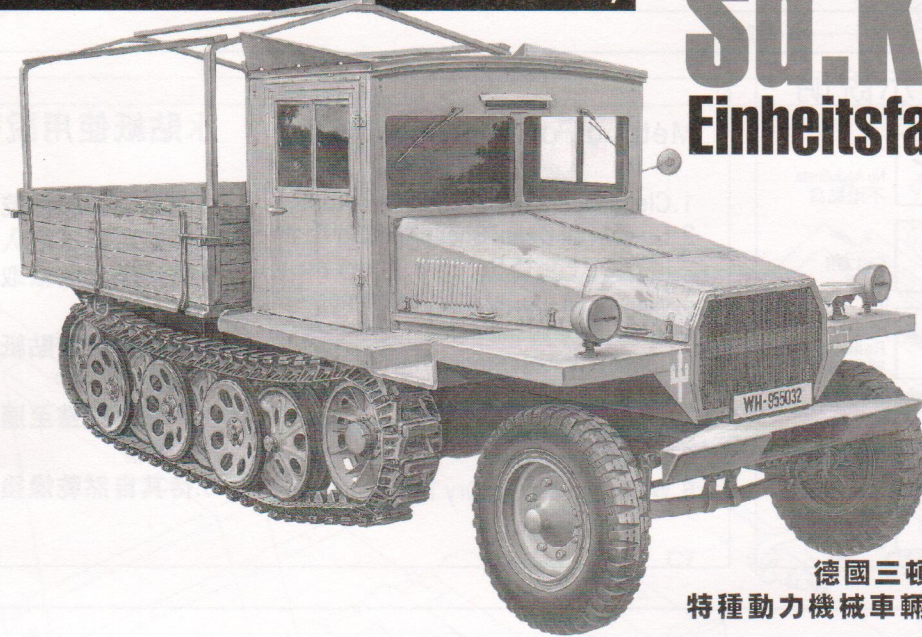

德國三噸輕型半履帶牽引車
特種動力機械車輛第11型後期生產型

Sd.Kfz. 11 3 ton half-track (LATE VERSION)

The SD.Kfz.11 Light Half-Track was originally designed for towing mid-size howitzer, and was widely adapted in all fronts throughout Europe and North Africa during WWII. Due to the lack of materials on later stages of the war, its production procedure had gone through considerable simplification. besides the chassis which remained unchanged, the later model heavily adopted parts of SD.Kfz.251, rendering it a significantly different look.

Due to the crucial need for steel of other war supplies, the upper hull of late-war SD.Kfz.11 was assembled largely with wooden material. Following the lengthening of its engine compartment, the driving cabin was modified to a tightly enclosed wooden structure. Similar to SD.Kfz.251, its steering wheel was also changed to a downward-tilting angle. Other than its original towing duty for artillery units, the usage of late-war SD.Kfz.11 had widely diversified, serving the Third Reich throughout the last days of the war.

S d . K f z 1 1 / 3 t ハーフトラック 最後期型

Sd.Kfz.11ハーフトラックは、本来中口径の榴弾砲を牽引するために設計され、第2次大戦中ヨーロッパから北アフリカに至るあらゆる戦線で広く運用されました。大戦後期になると、資材の不足により、生産工程が大幅に簡略化されることとなり、変更のなかったシャシー部を除き大幅にSd.Kfz.251との部品共通化が図られ、大きく外観を変えることになりました。

戦争による大幅な鉄の需要増により、後期型Sd.Kfz.11は、上部構造の大部分が木製で製造され、エンジンコンパートメントの延長とともに、運転席は密閉式の木製キャビンタイプに変更されました。Sd.Kfz.251と同様、そのハンドルは下方に向く角度に改造されています。後期型Sd.Kfz.11は、本来の砲牽引用途のみならず、大戦末期のドイツ軍によりさまざまな用途に幅広く利用されました。

Sd. Kfz. 11後期型

Sd. Kfz. 11輕型半履帶牽引車, 原本設計專門用做中型火砲牽引之用, 在二戰全期的歐洲及北非的各個戰場都十分活躍, 但隨著二戰後期戰略物資的缺乏, 及生產過程簡易化的考慮, 後期生產的Sd. Kfz. 11大量沿用了與Sd. Kfz. 251共通的零件, 因此除了底盤維持與標準型相同的型式外, 全車在外觀上產生了很大的變化。

由於鋼鐵轉用於其他的軍需物資, Sd. Kfz. 11後期型之上車身大量採用木材製造, 車頭的引擎室因為配合Sd. Kfz. 251的機件而加長, 使得駕駛室後移, 駕駛室改為木構造的密閉型式, 其內部的方向盤也與Sd. Kfz. 251相同而改為向下傾斜, 主要任務也由火砲牽引轉變為廣泛用途的載重車, 伴隨第三帝國走過最後一段歲月。

Illustration:圖示說明



Method For Applying Decals:

1. Clean Model Surface With Wet Cloth.
2. Cut Out Of Decal Sheet And Dip Them In Water For 15 Seconds.
3. Place it on proper position on model.
4. Slide off base paper leaving decals On Model With Wet Finger Tip.
5. Move Decals To Exact Position, Push Out Excess Water Under Decal With Soft Cotton Cloth.
6. When Decals Get Dry Then Complete.

水貼紙使用說明:

1. 將模型表面擦乾淨
2. 將貼紙剪下泡入清水中約15秒
3. 將泡濕之貼紙取出置於欲貼處旁
4. 用指尖輕推貼紙表面使其滑出底紙
5. 將貼紙調整至適當位置並輕擦拭水份
6. 待其自然乾燥後即完成

Color list: 塗料表

Color	Brand	GSI Creos (Gunze Sangyo)			Humbrol	Revell	Life Color
		Hobby Color	Mr. Color	Mr. Color Spray			
Dark yellow	深黃	H-79	C-39	J-39	83	16	UA081
Steel	黑鐵	H-18	C-28	J-28	53	91	LC76
Tire black	輪胎黑	H-77	C-137		85	302	LC02
Flat white	消光白	H-11	C-62	J-62	34	05	LC01
Red brown	紅褐	H-47	C-41	J-44	160	383	UA082
Silver	銀	H-8	C-8	J-8	11	90	LC74
Khaki	卡其	H-81	C-55		159		UA097
Red	紅	H-3	C-3	J-3	19	31	LC56
Metallic green	亮綠	H-89	C-77	J-77	131	364	



(AF 35040)
Sd. Kfz. 11
3t half-track

1

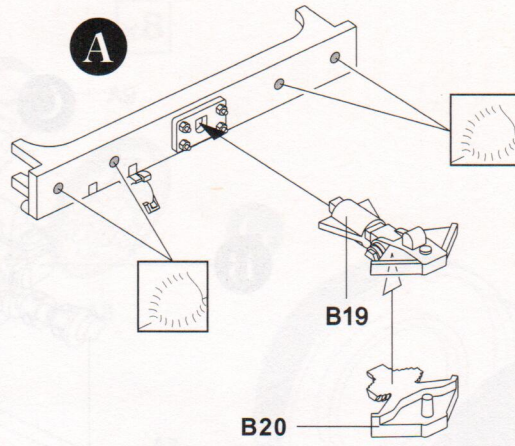
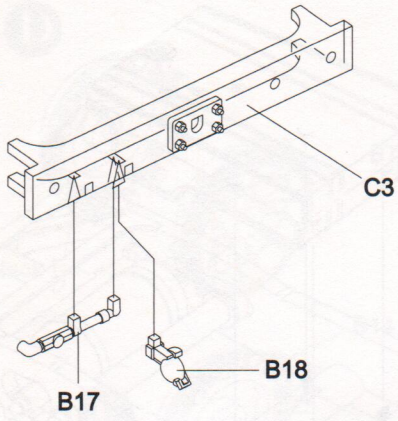

2

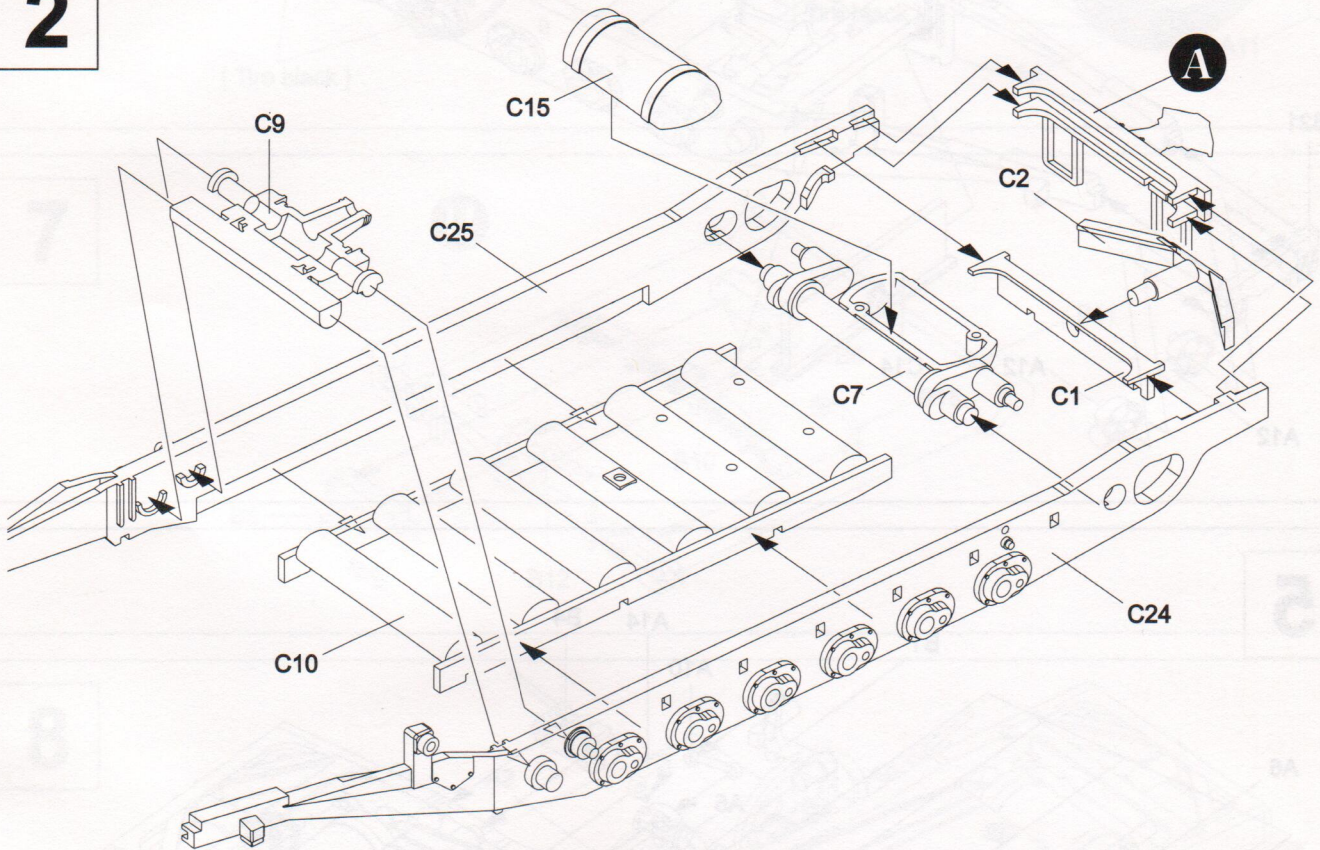

3

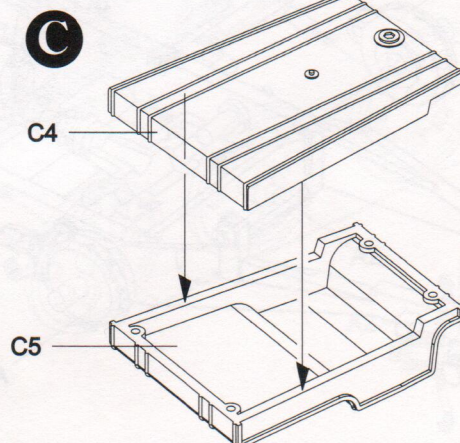
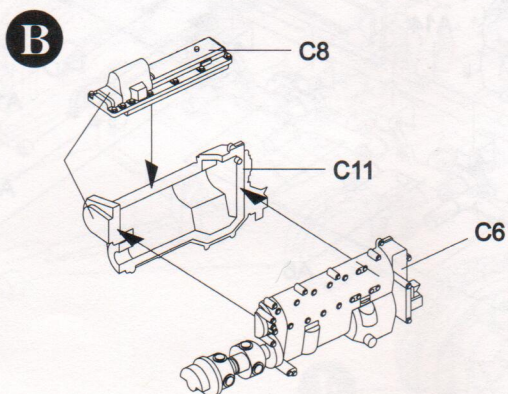

4

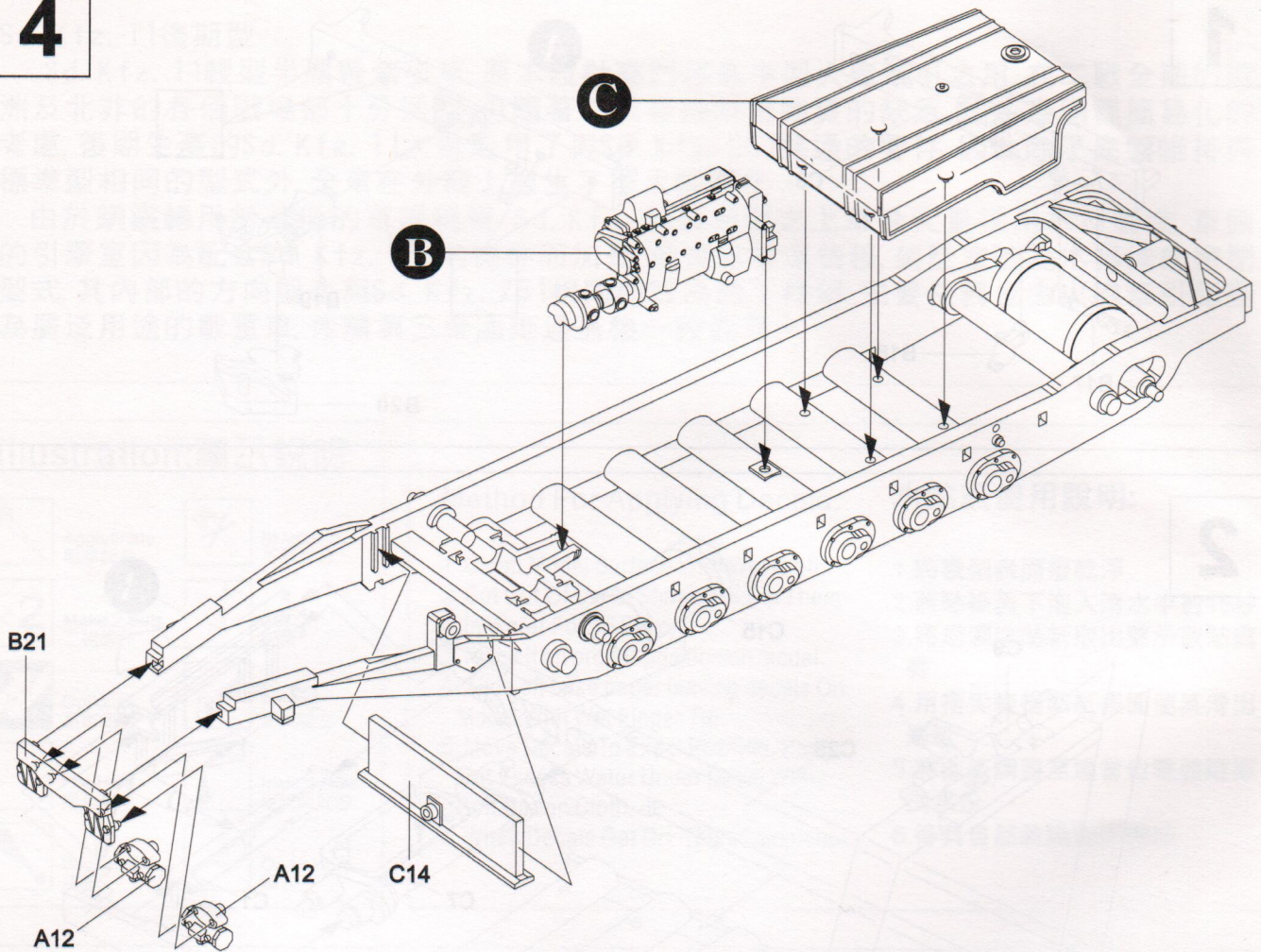

5

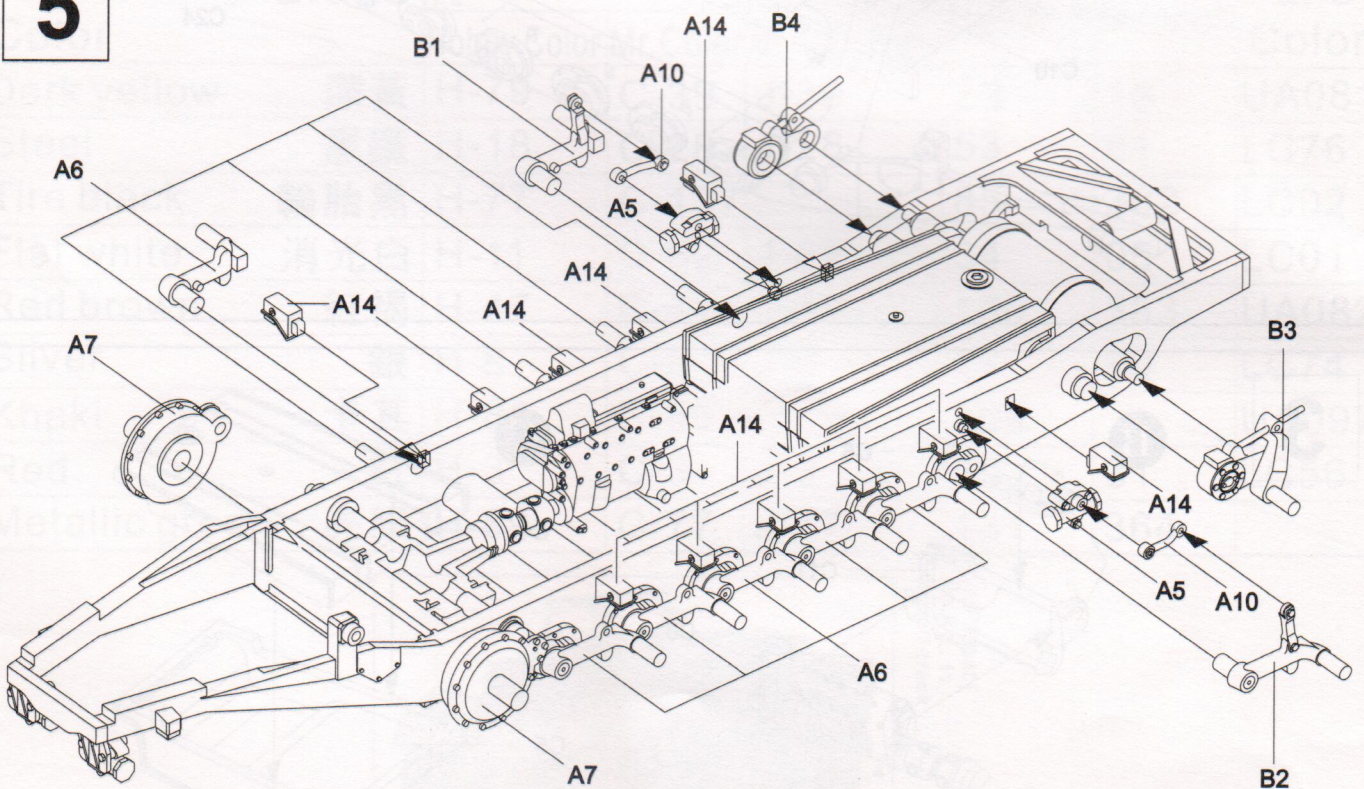

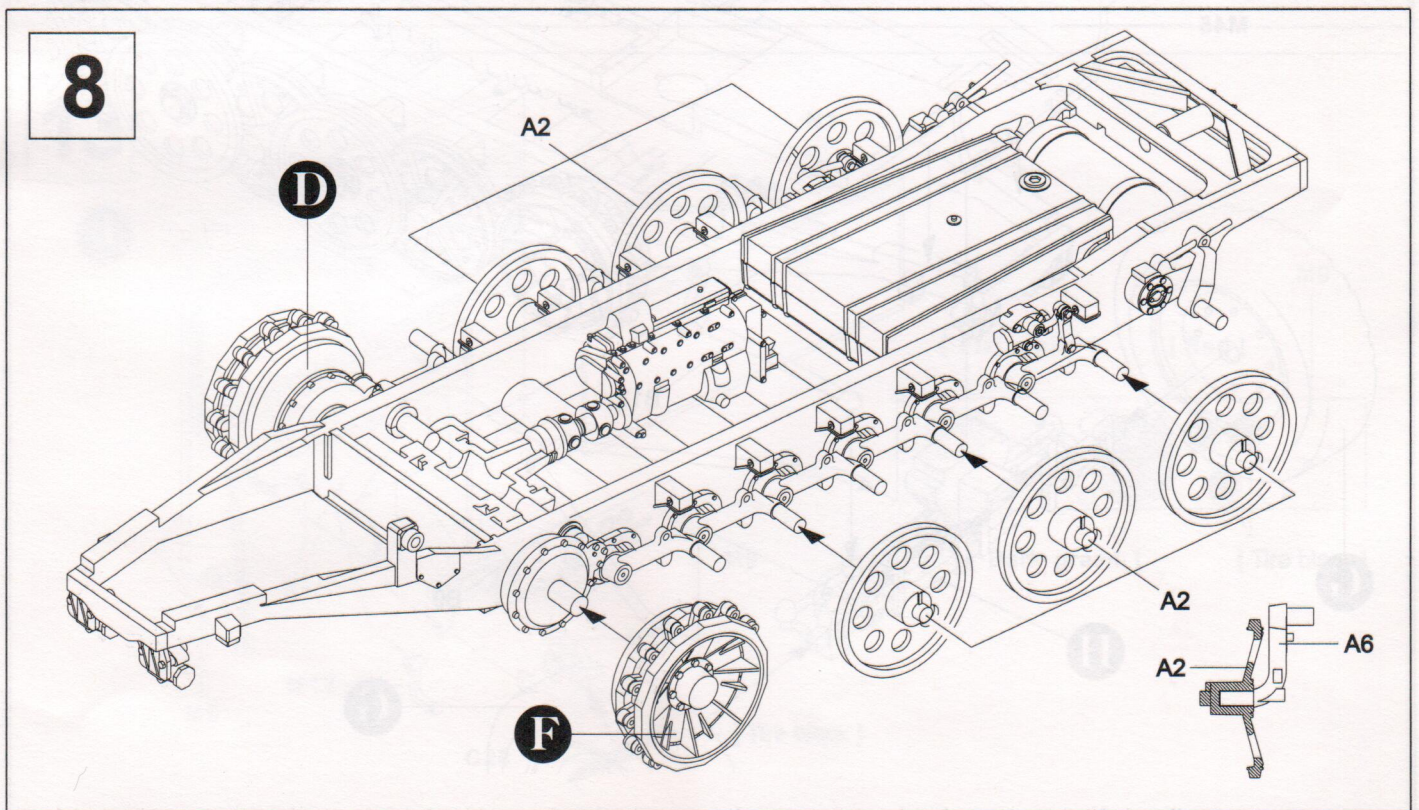
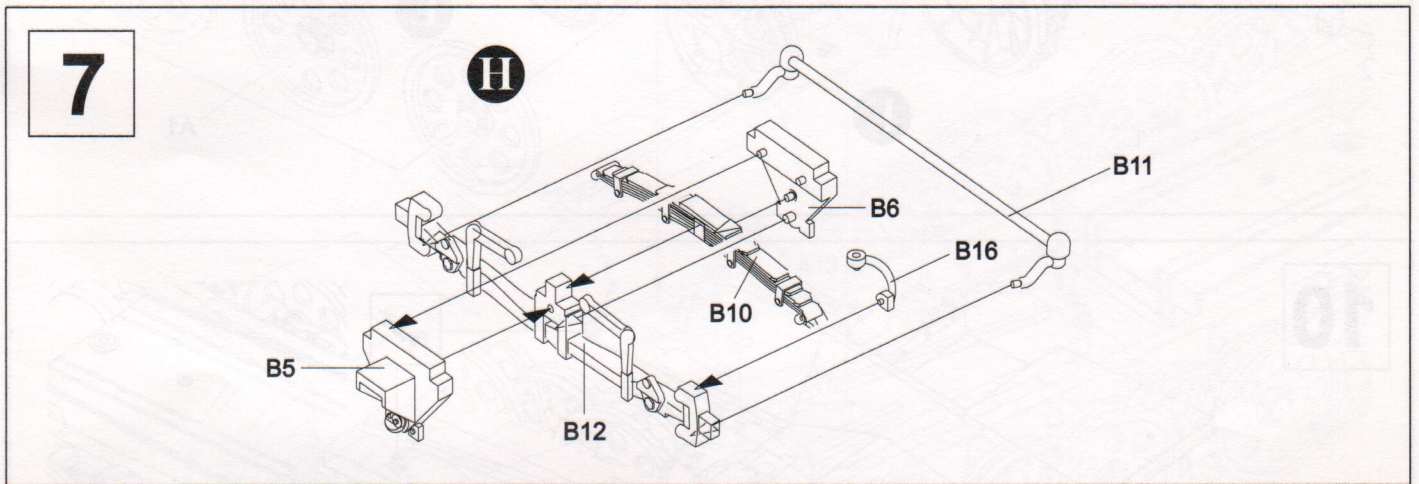
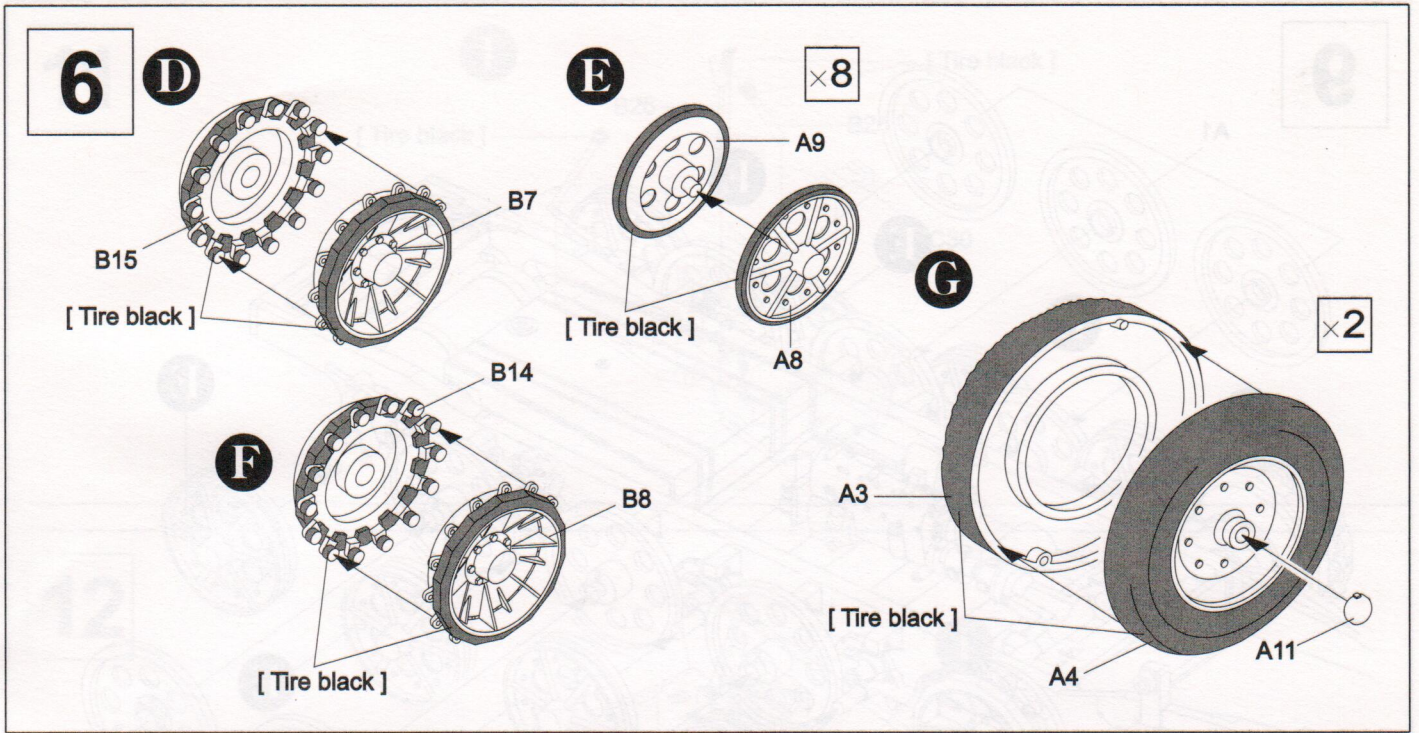

9

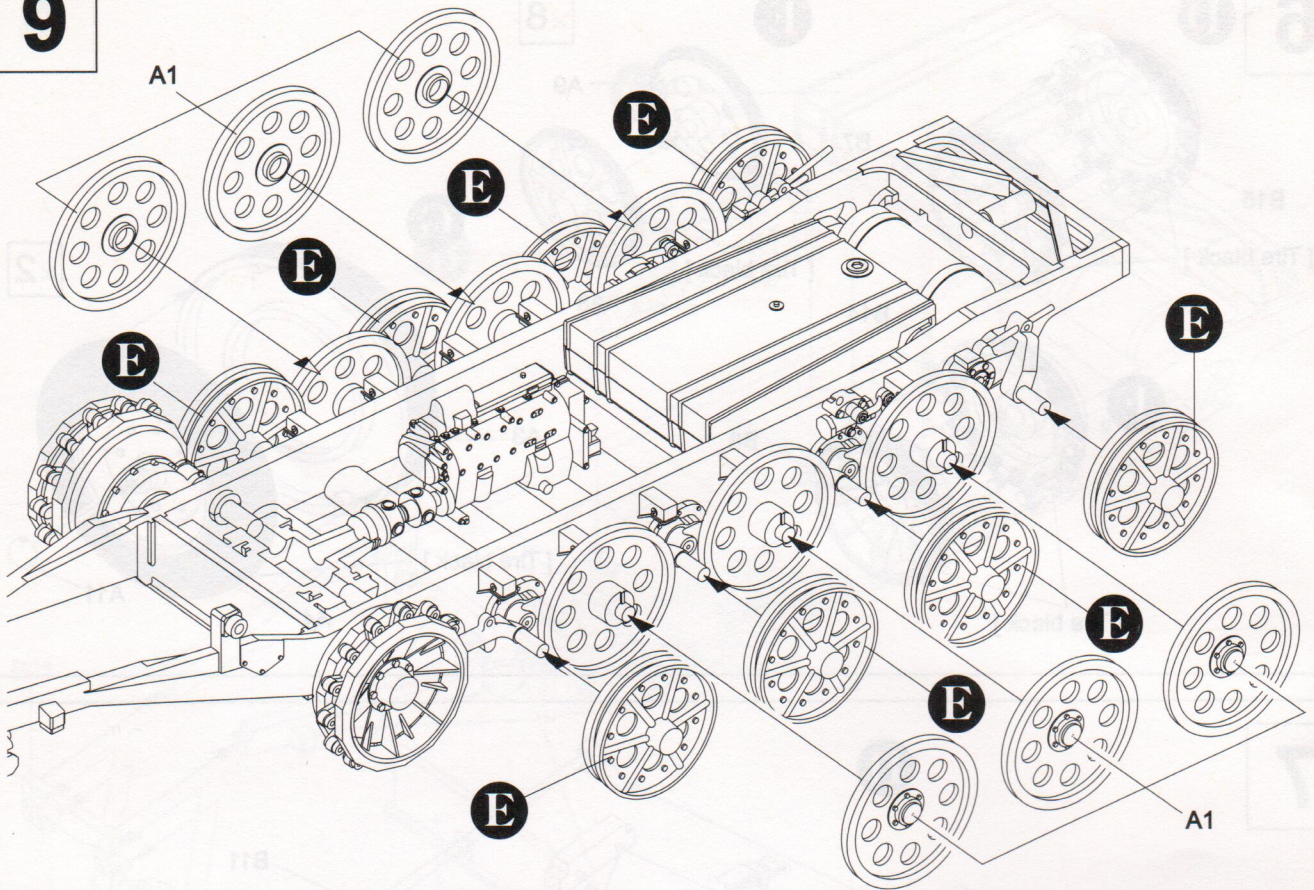

10

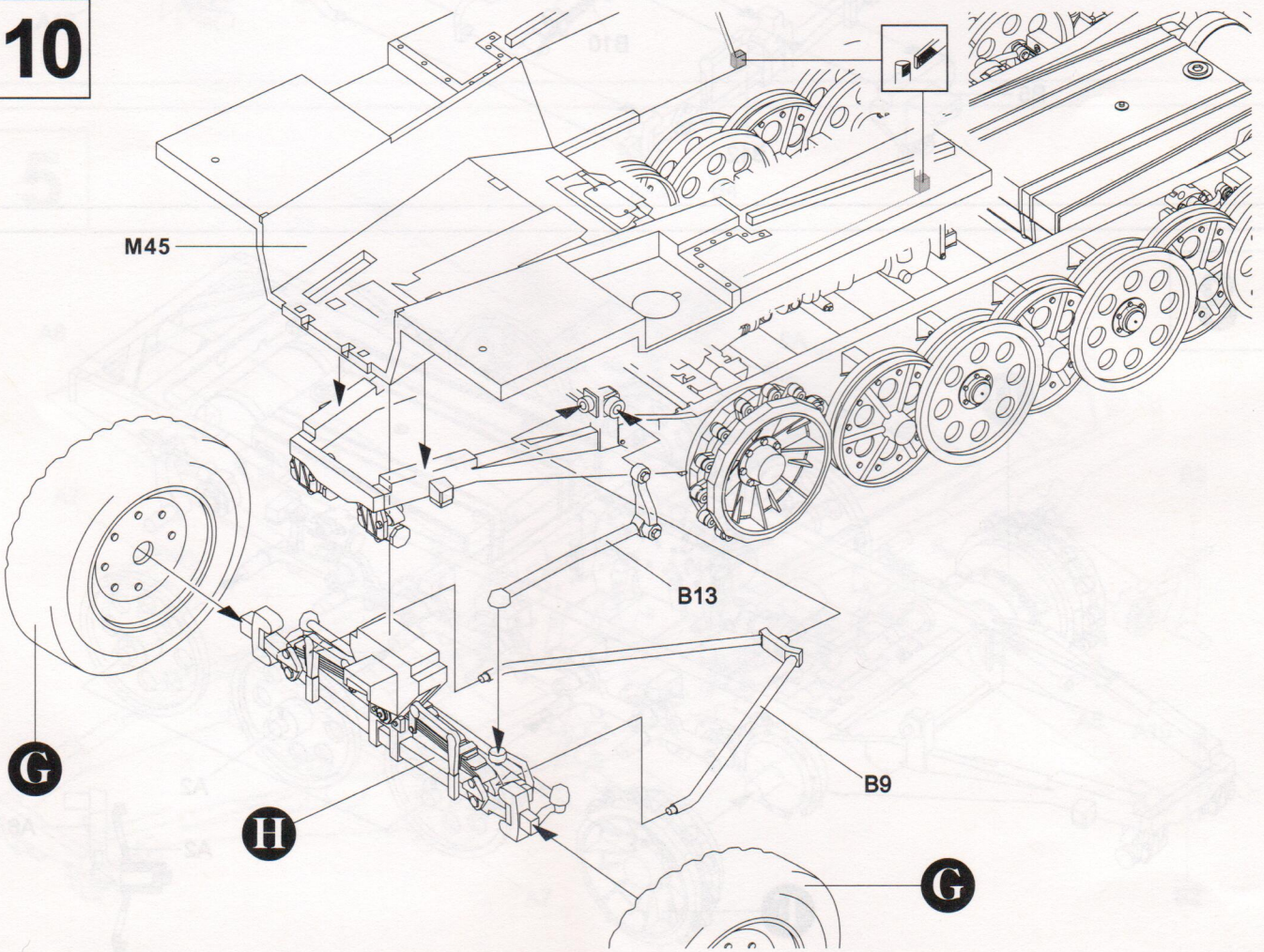

11

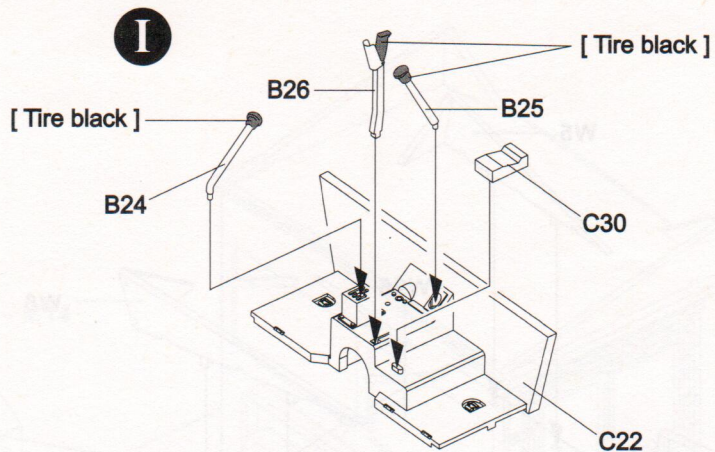

12

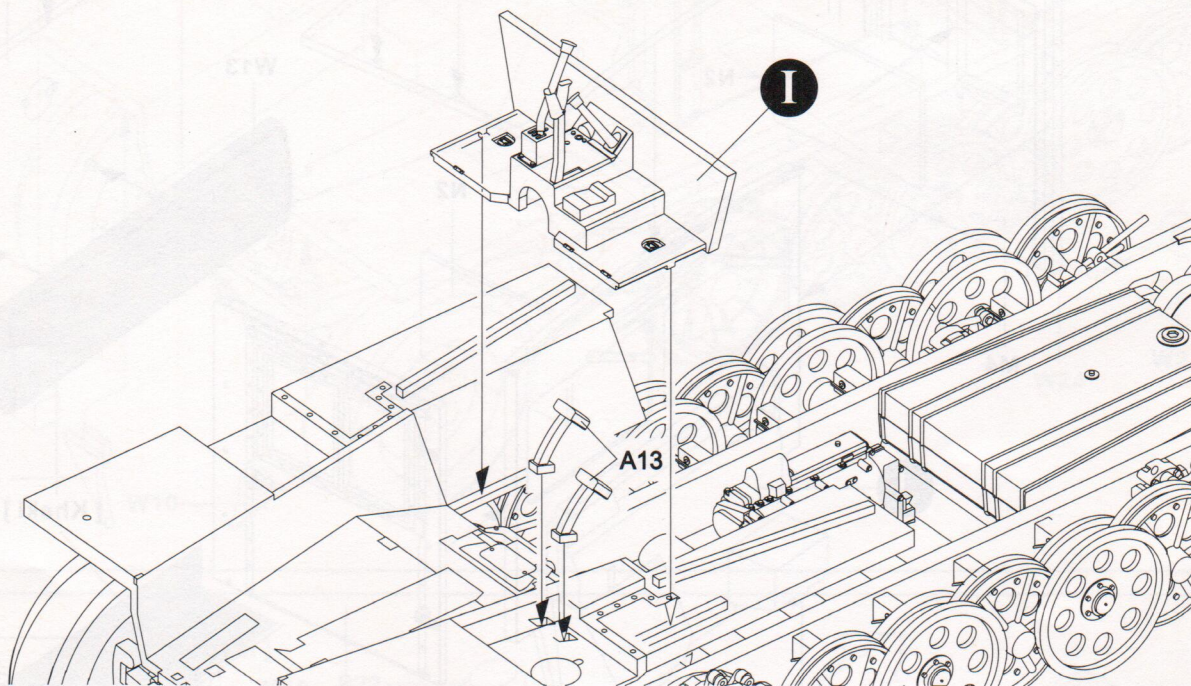

13

J

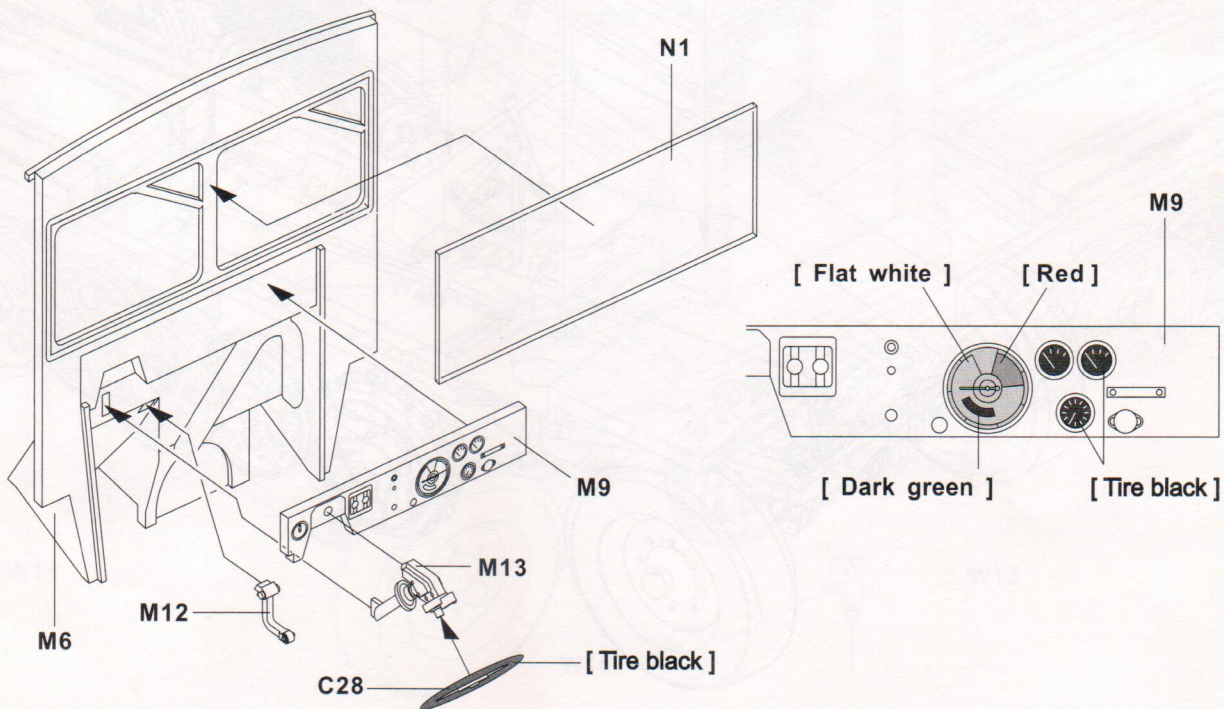

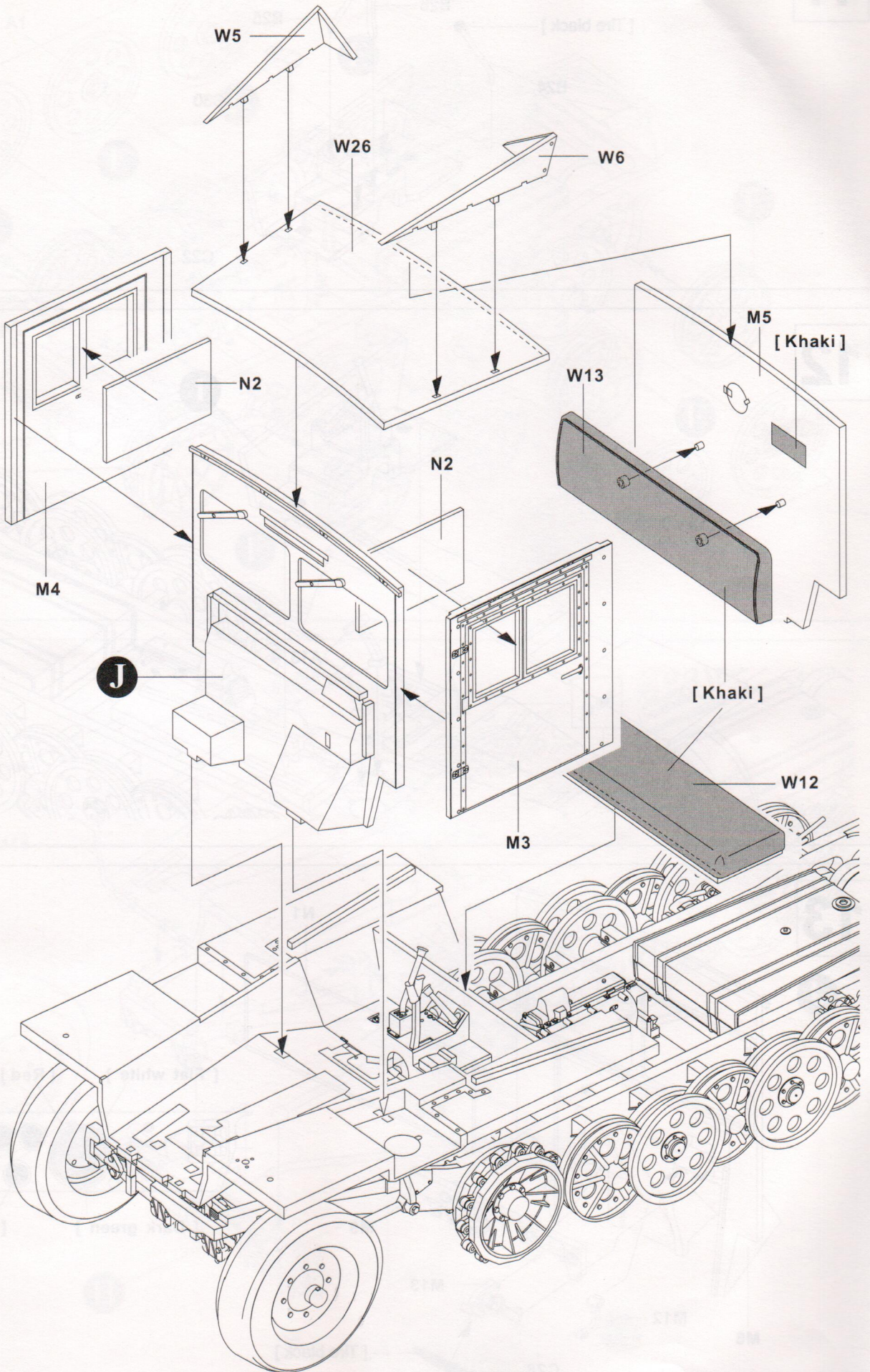

15

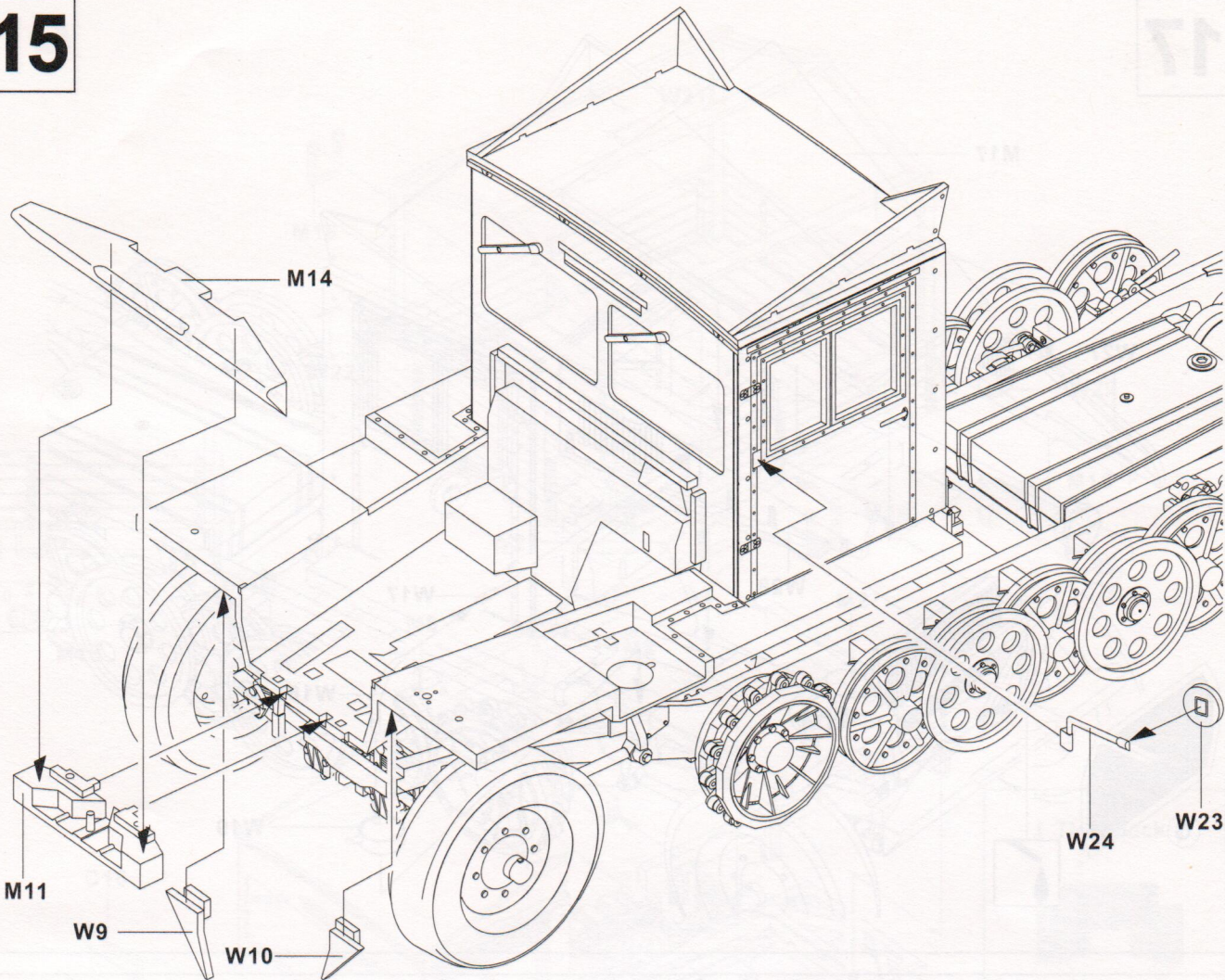

16

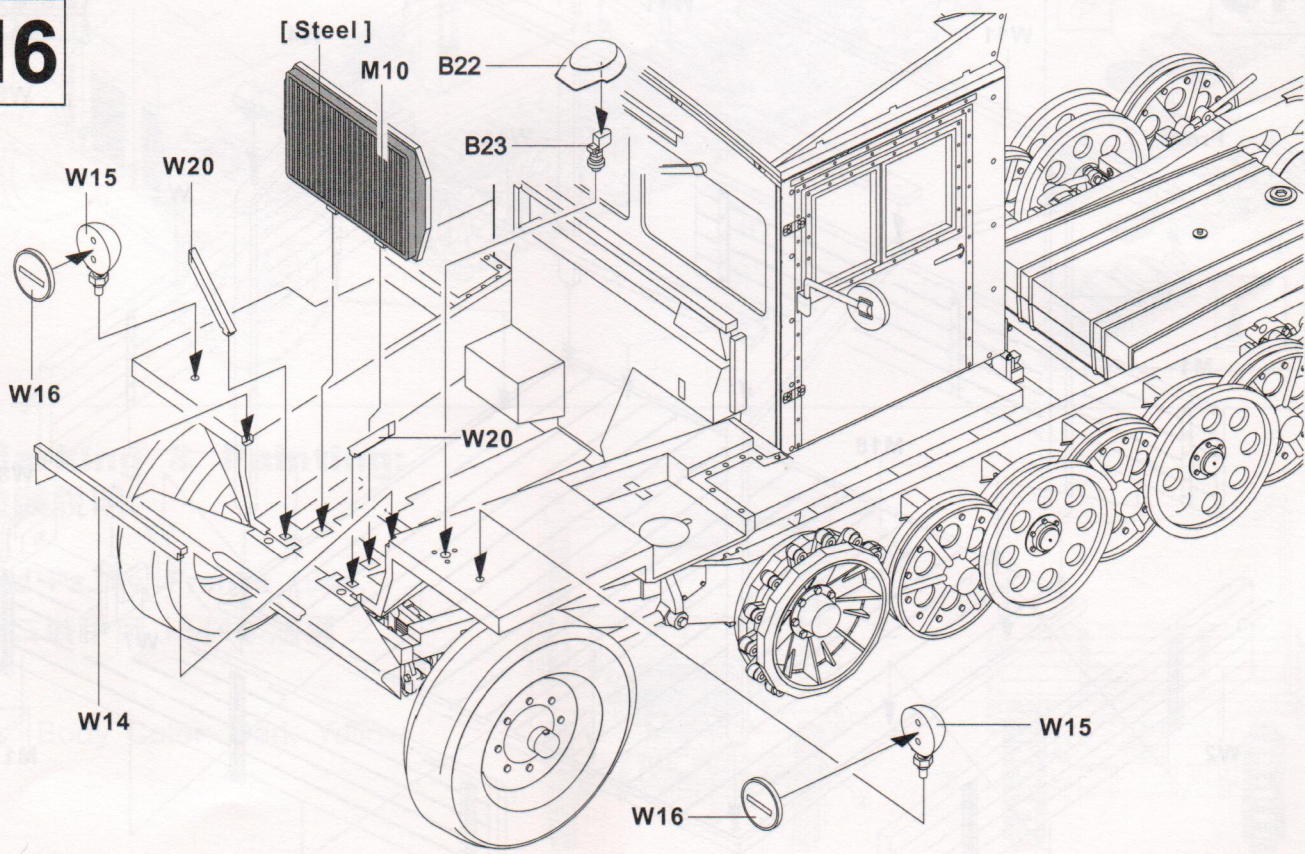

17

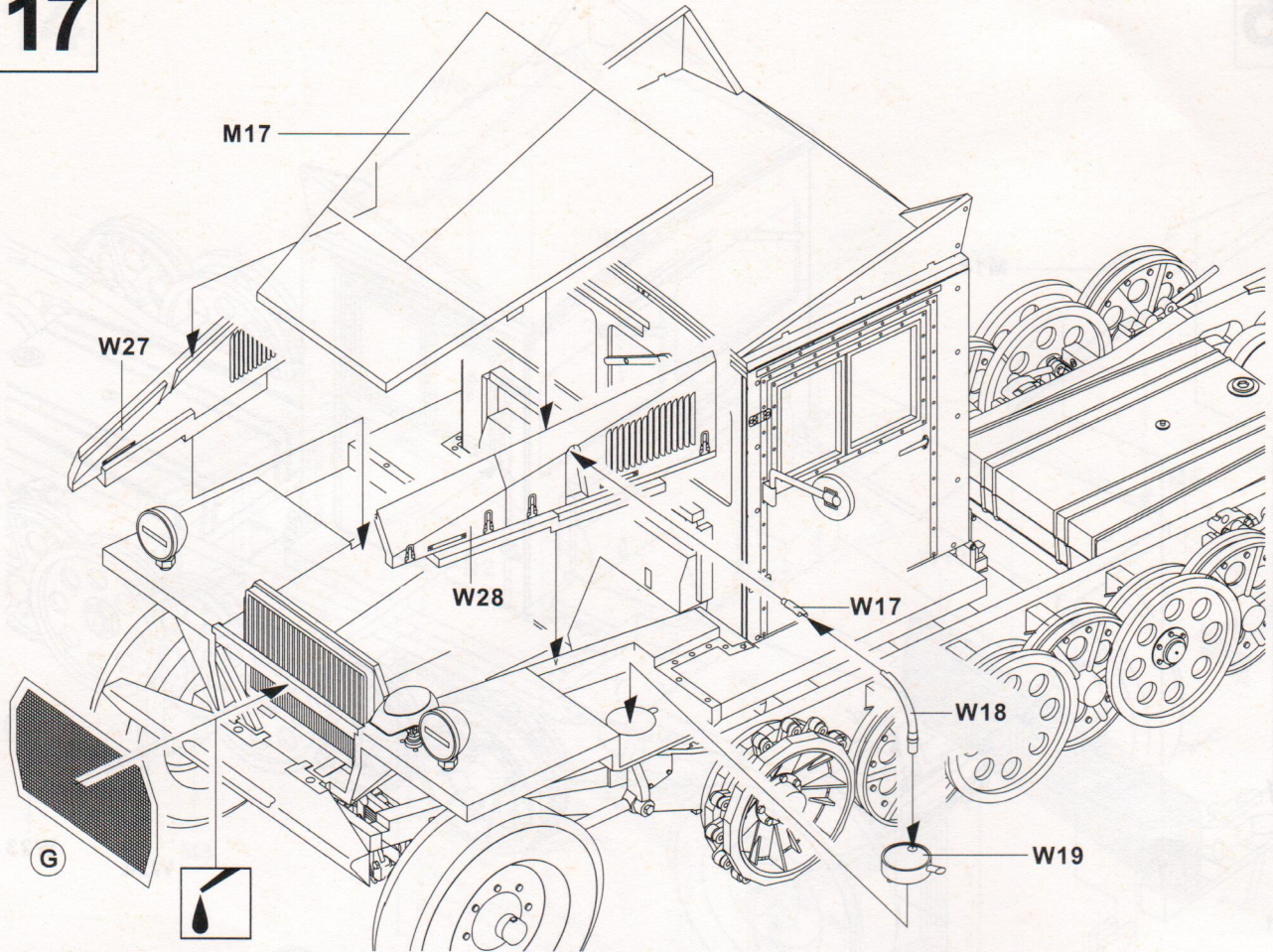

18

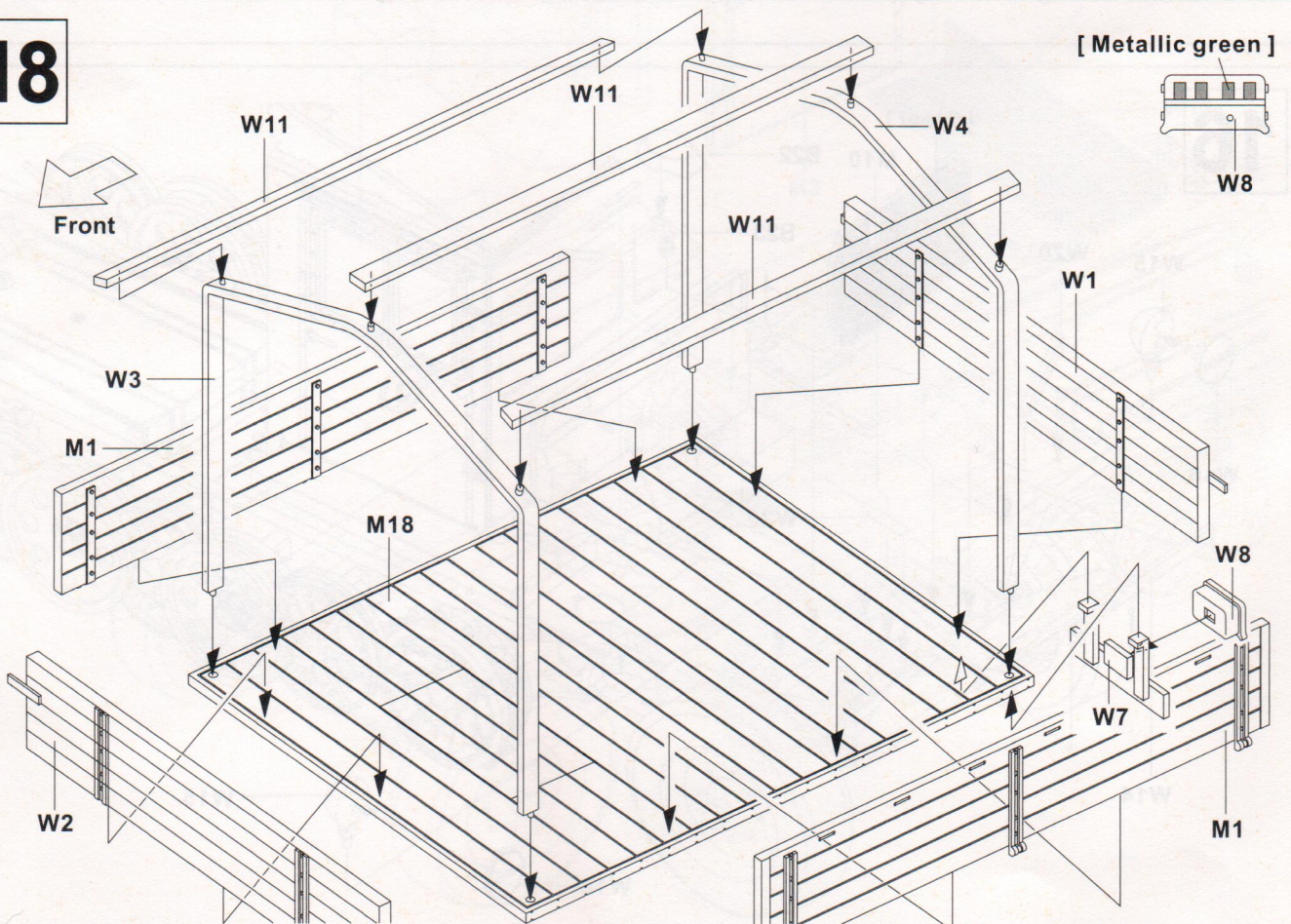

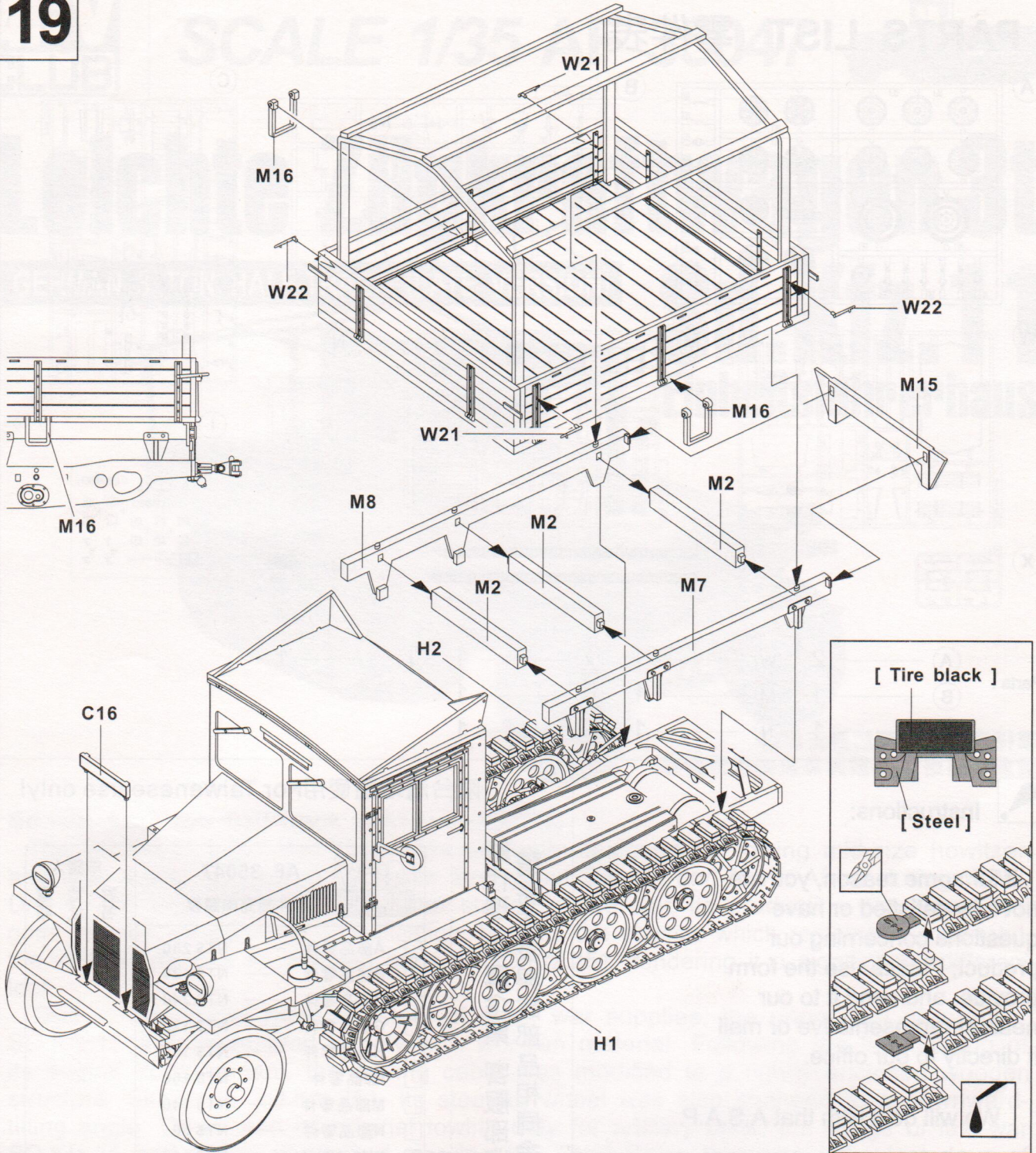

Marking & Painting:
 塗裝說明:

2nd Pz.Div, France 1944.
 第二裝甲師, 1944年法國

 Body Color: Dark Yellow

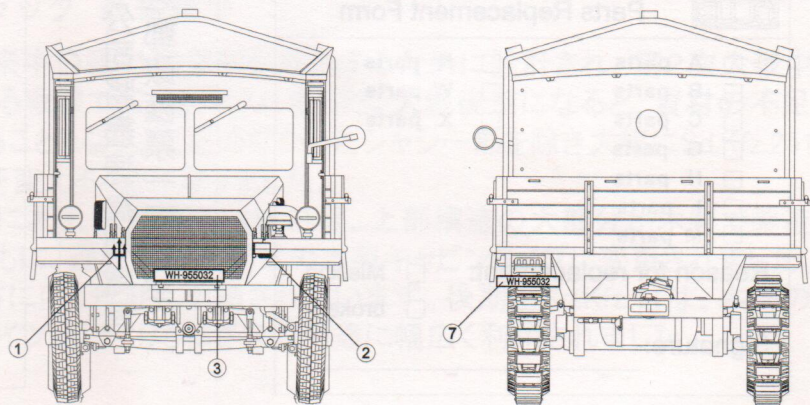

PARTS LIST 零件表

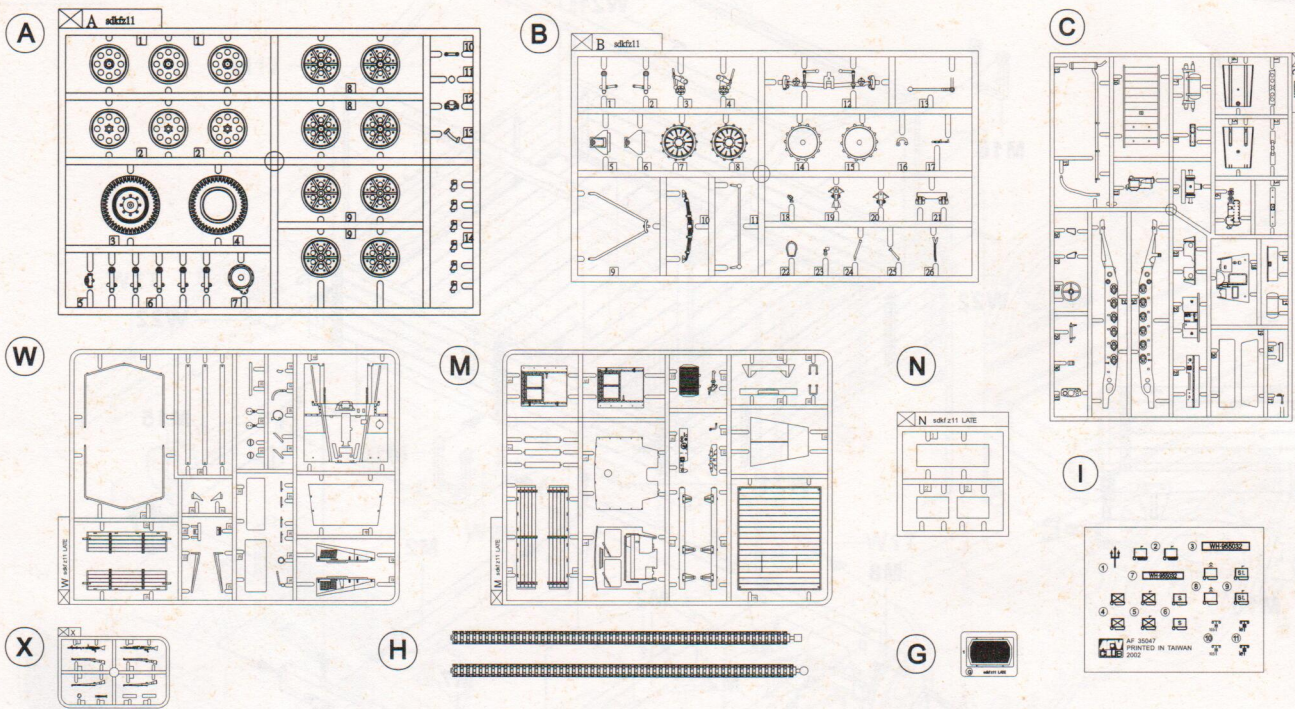

Parts :

A ————— 2	W ————— 1	X ————— 1	I ————— 1
B ————— 1	M ————— 1	G ————— 1	
C ————— 1	N ————— 1	H ————— 1	



Instructions:

If for some reason, you are not fully satisfied or have questions concerning our product; Please use the form provide, and send it to our nearest representative or mail it directly to our office.

We will deal with that A.S.A.P.

AF 35047
Parts Replacement Form

<input type="checkbox"/> A parts	<input type="checkbox"/> N parts
<input type="checkbox"/> B parts	<input type="checkbox"/> W parts
<input type="checkbox"/> C parts	<input type="checkbox"/> X parts
<input type="checkbox"/> G parts	
<input type="checkbox"/> H parts	
<input type="checkbox"/> I parts	
<input type="checkbox"/> M parts	

Reason for replacement: Missing broken

Signature: _____

限台灣地區使用 For Taiwanese use only!

總代理：戰鷹企業 客服部收 本公司將盡速為您處理
 請將本表與該部品相同金額之郵政匯票一同寄至

AF 35047
零件補充申請表

申請人
 姓 地 電
 名 址 話
 : : :

<input type="checkbox"/> A部品零件	——	NT\$ 280
<input type="checkbox"/> B部品零件	——	NT\$ 120
<input type="checkbox"/> C部品零件	——	NT\$ 240
<input type="checkbox"/> G部品零件	——	NT\$ 120
<input type="checkbox"/> H部品零件	——	NT\$ 160
<input type="checkbox"/> I部品零件	——	NT\$ 160
<input type="checkbox"/> M部品零件	——	NT\$ 140
<input type="checkbox"/> N部品零件	——	NT\$ 60
<input type="checkbox"/> W部品零件	——	NT\$ 160
<input type="checkbox"/> X部品零件	——	NT\$ 60

(請填) 總計 NT\$ _____

零件補充原因: (請於 打)

· 原包裝即 遺失或 毀損

· 製作途中 遺失或 毀損

補充多餘零件

· 其他原因 _____