

M10

TANK DESTROYER

M10 驅逐戰車



M-10 DESTROYER

In WWI, tanks were mainly used as fire support and provide mobile cover for advancing foot soldiers. For same reason, the performance of tanks were often limited due to slow movement of infantry and the full potential and the destructive power of tanks in the battle field were never fully realized. Seeing this potential threat, the US armed Force realized the need for a defensive vehicle with massive firepower to protect infantry against enemy tanks in future battlefields. As a result, "Tank destroyer" is being developed. This concept is different from the UK doctrine to combine speed and protective armor only for their "Infantry Tank" concept.

In December, 1941, M7 76.2mm gun was adopted to a M4A2 and was assigned as T-35. It adopted the basic T-34 design with a open top turret. This design allows lower overall height while the sloped sides will help to deflect incoming rounds. In June, 1942, the basic shape was changed from roundel to a pentagon with extra armor at rear of turret as counter weight. The design was redesigned as M10 and from Sept, 42 to Dec, 43, 4993 M10s were produced.

In March, 43, the M10 had it's first baptize in Tunisia, North Africa and subsequently entered service in the Pacific, Italian and European campaign. Improvements are constantly made to include the use of the M4A3 chassis M10A1. Later on, the M10 was upgraded to have motor driven turret mechanism. For a batter match for the Axis tanks, a 90mm main gun version, M36 was developed in July, 44. Earlier M10 were stripped and used as prime movers for heavier field artillery. Out side of the US armed forces, approximately 3,000 M10 were supplied to UK, France as well as other Allied countries and many remain in service long after WWII.

M10 data:

Length/Width/Height: 5.96/3.04/2.89M Armament: 76mm M7 anti-tank gun x1, 12.7mm machine gun x1
 Engine: Twin GM 6046 twelve-cylinder inline diesel, 420 bhp/2100rpm Weight: 29.6 ton Speed: 48km/h Crew: 5

M-10 驅逐戰車

第一次世界大戰時,戰車在戰場上只是擔任步兵火力援護及敵方塹壕突破的任務,但由於步兵移動速度緩慢及分散作戰的特性,使得伴隨的戰車在戰術上受到局限,無法藉集中且快速的運動來充分發揮戰力。美國陸軍因此體認到步兵亟需一種以防禦為主,能提供有效反裝甲火力的裝甲戰鬥車輛,使步兵免於受敵方戰車的攻擊,來取代過去戰車在步兵部隊中的角色,美國陸軍將這種兵器稱之為「驅逐戰車」,有別於英國以速度與裝甲防護力為標準來劃分的「步兵戰車」。

1941年12月以M-4A2「雪曼」之底盤搭載一門M7 76.2mm戰車砲,試作車以T-35為名,具備了開放式全周迴旋砲塔,並以蘇聯T-34戰車外型為樣本,除將車身降低外,同時兩側裝甲由垂直改為傾斜,以增加避彈效果,1942年6月將原本砲塔由圓形改為五角型,並於砲塔後方增加配重用裝甲,重新命名為M-10,自1942年9月至翌年12月共生產4993輛。

1943年3月北非突尼西亞戰役M-10首度登場,隨後陸續投入太平洋、義大利及西歐等戰線。而M-10之改良案仍繼續推動;1942年10月起使用M-4A3底盤新式車身之M-10A1開始並行生產,1943年春起,出廠車輛加裝砲塔動力迴旋裝置,又為了能與德國重型戰車對抗,配備90mm戰車砲的後繼車M-36於1944年7月制式化,而部分早期型M-10在拆除砲塔後專司155mm以上重型火炮牽引。除美國外約有3600輛M-10供應英國及自由法國等盟軍,戰後仍有許多國家長期繼續使用。

M10 性能諸元:

車身長/寬/高: 5.96/3.04/2.89 公尺 武裝: 76 公厘 M7 型反戰車砲 x1, 12.7 公厘機槍 x1
 動力: 通用水冷 6 氣缸柴油引擎, 420 匹馬力 重量: 29.6 公噸 速度: 48 公里/小時 乘員: 5 名

M-10 駆逐戦車

第一次大戦において戦車の主な用途は、火力支援と歩兵随伴支援でした。そのような状況下戦車の能力は、歩兵の進撃速度が遅いことにより、しばしば制限されることがあり、戦場での戦車の能力や破壊力を完全に発揮することができませんでした。しかし潜在的な能力に脅威を感じたアメリカ陸軍は、将来戦場において敵戦車に対して歩兵を守るための、強力な火力を持った対戦車車両の必要性があることを実感していました。その結果「駆逐戦車」の開発が始まったのです。この考えは、スピードと自らの歩兵戦車に対抗できるだけの装甲を持つという英国の方針と異なるものでした。

1941年12月、M7 76.2mm 砲はM4A2に搭載され、T35となりました。これにはもともとT34に設計されたオープントップ砲塔が載せられており、このデザインは全高を低くするとともに、傾斜した側面は跳弾性を高めるのに役立つものでした。1942年6月砲塔の基本型が円形よりカウンターウエイトとして砲塔後部に追加装甲を取り付けた五角形に変更されました。この設計、M10として再設計され、1942年9月から43年12月までに4,993両が製造されました。

1943年3月北アフリカのチュニジアで初めて砲火の洗礼を受けたM10は、続いて太平洋、イタリア、ヨーロッパ戦線に投入されてゆきました。開発は続けられ、M4A3 シャーシを利用したM10A1が誕生しています。後にM10はモーター式の駆動砲塔に良されています。ドイツ軍戦車に対抗するため、90mm 砲塔戦のM36が1944年7月に誕生しました。初期のM10は改造され、重砲用の弾薬補給車に利用されました。米軍以外に約3,000両が英、仏などの連合国に供与され、第二次大戦以降も長期にわたって使用されました。

Illustration: 圖示説明



Method for applying decals:

水貼紙使用説明:

1. Clean model surface with wet cloth.
2. Cut out of decal sheet and dip them in water for 15 seconds.
3. Place it on proper position on model.
4. Slide off base paper leaving decals on model with wet finger tip.
5. Move decals to exact position, push out excess water under decal with soft cotton cloth.
6. When decals get dry then complete.

1. 將模型表面擦乾淨
2. 將貼紙剪下泡入清水中約15秒
3. 將泡濕之貼紙取出置於欲貼處旁
4. 用指尖輕推貼紙表面使其滑出底紙
5. 將貼紙調整至適當位置並輕擦拭水份
6. 待其自然乾燥後即完成

Color list: 塗料表

Color	Brand	Gunze			Humbrol	Revell
		Hobby Color	Mr. Color	Mr. Color Spray		
Olive drab	橄欖綠	H-78	C-38	J-38	66	46
Steel	黑鐵	H-18	C-28	J-28	53	91
Tire black	輪胎黑	H-77	C-33+C-62		85	302
Flat black	消光黑	H-12	C-33	J-33	33	08
Flat white	消光白	H-11	C-62	J-62	34	05
Red	紅	H-3	C-3	J-3	19	31
Bright blue	寶藍	H-15	C-65	J-65	14	51
Red brown	紅褐	H-47	C-41	J-44	160	383
Silver	銀	H-8	C-8	J-8	11	90
Tan	皮革	H-27	C-44	J-44	118	
Olive Green	橄欖綠		C-120		161	361
Brass	黃銅		C-9	J-9	54	92

1

Interior

Radio

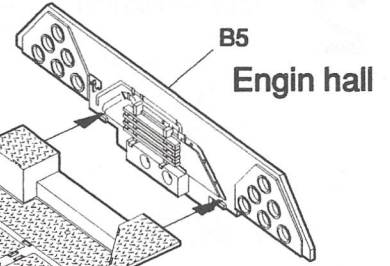

Assistant Driver's Seat

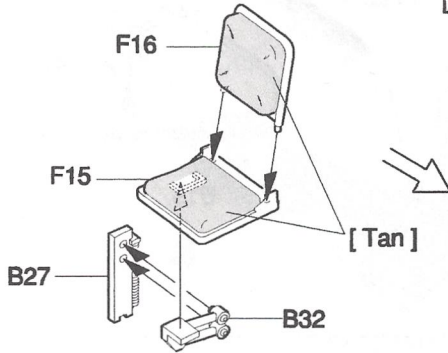

Interior painting
内部塗装
[Flat White]

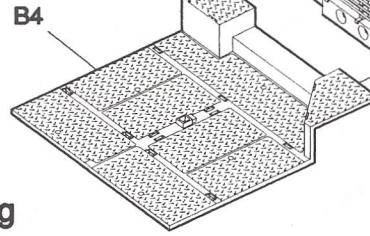

Driver's Seat

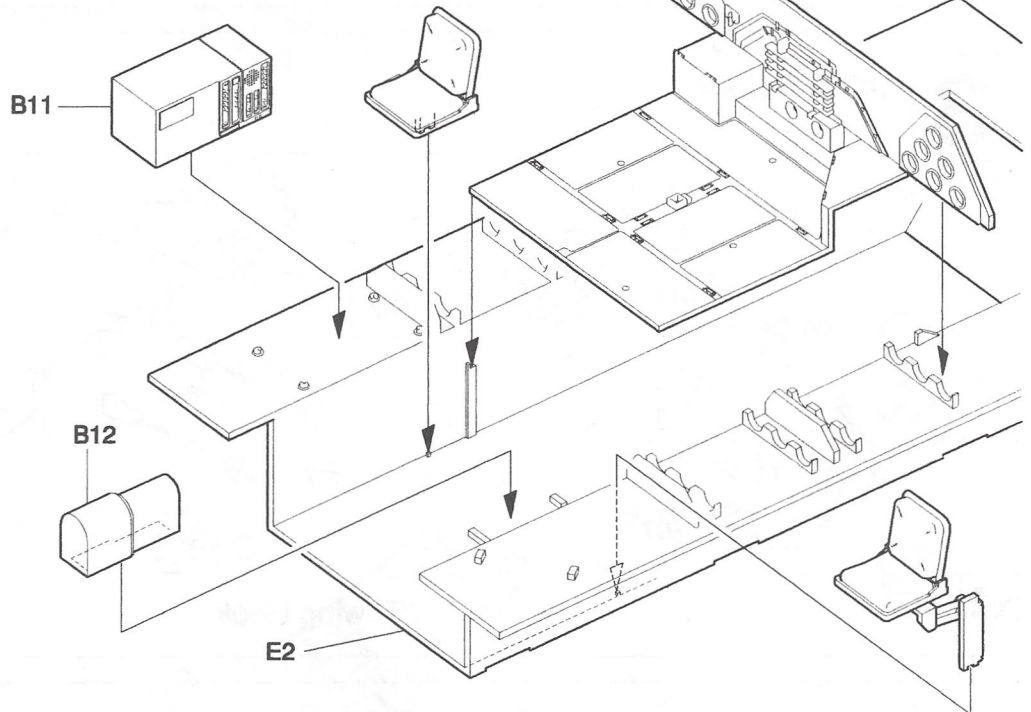
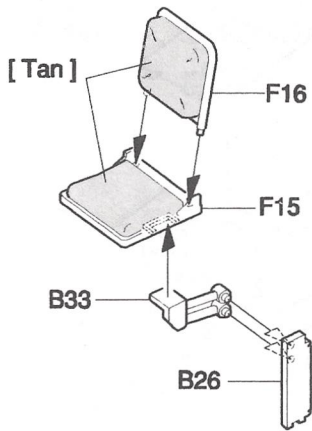

Instrument panel

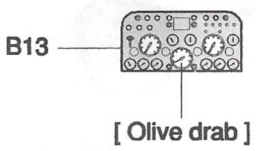

[Flat black]

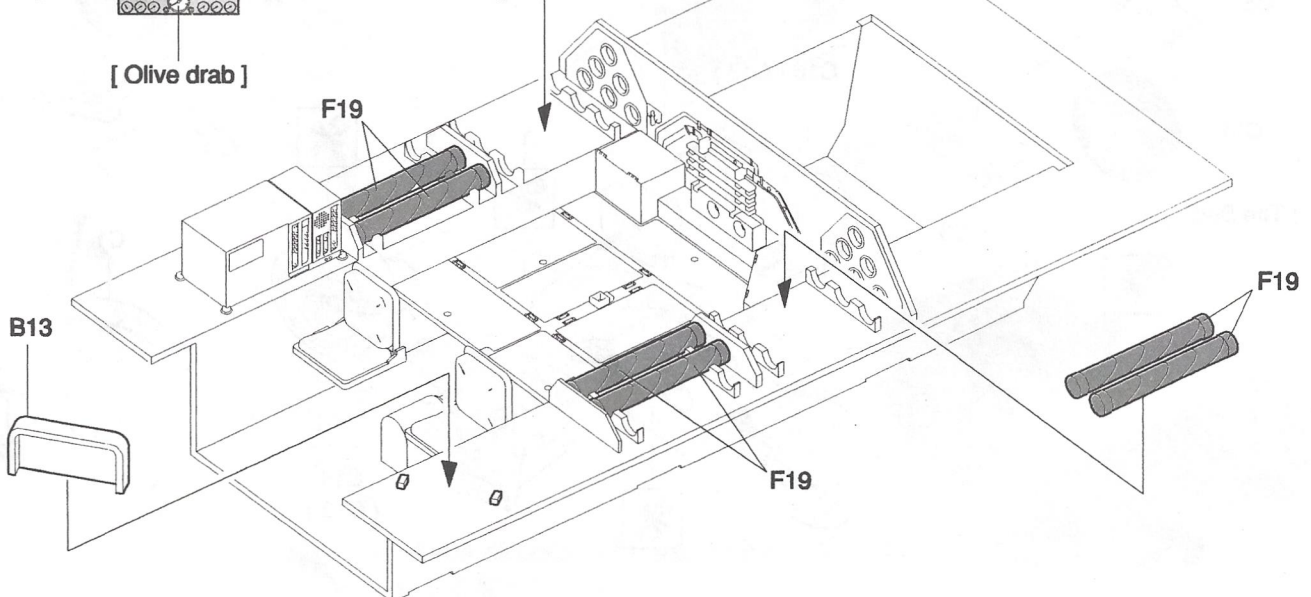
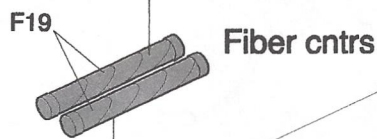

2

Transmission

Diagram of relative location
相關位置參考圖

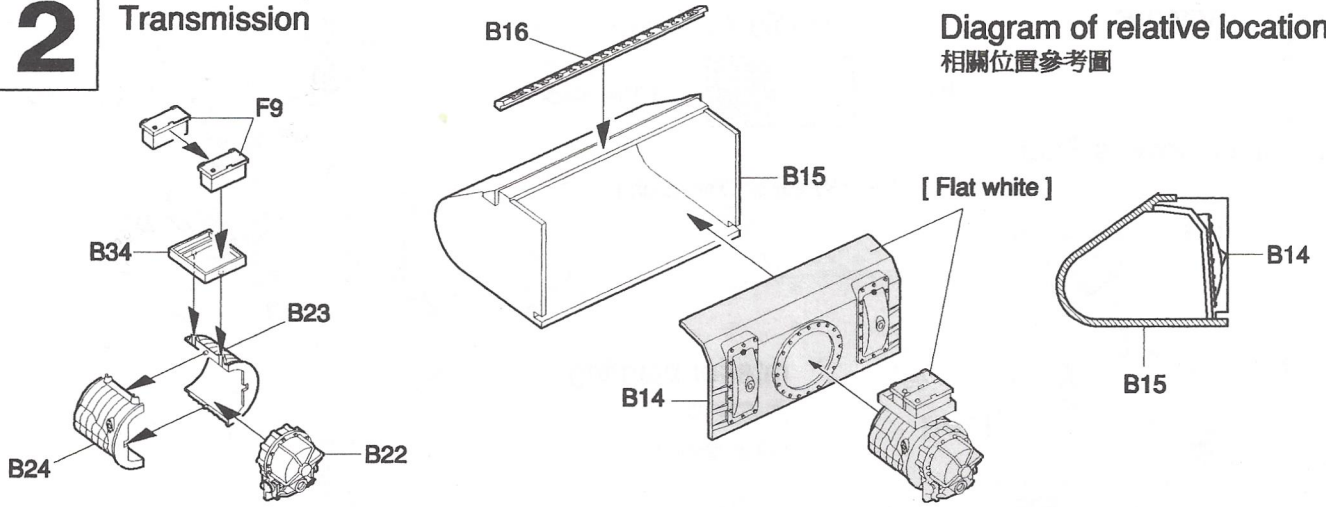

3

Driver Sprocket

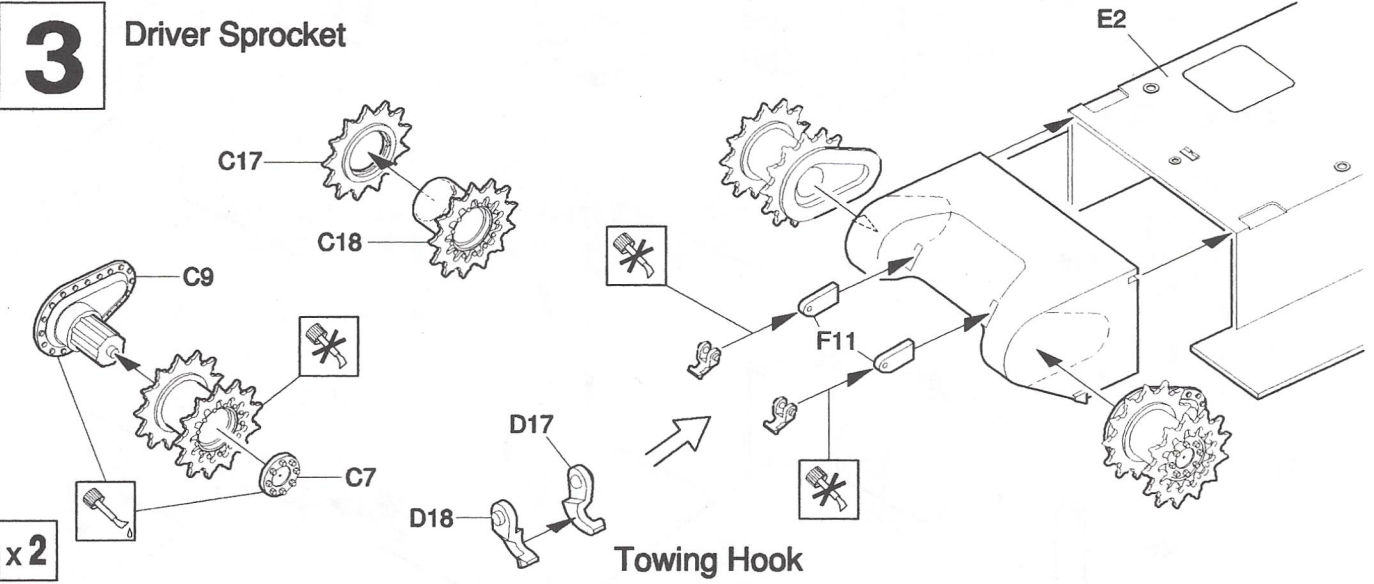

4

Suspension System

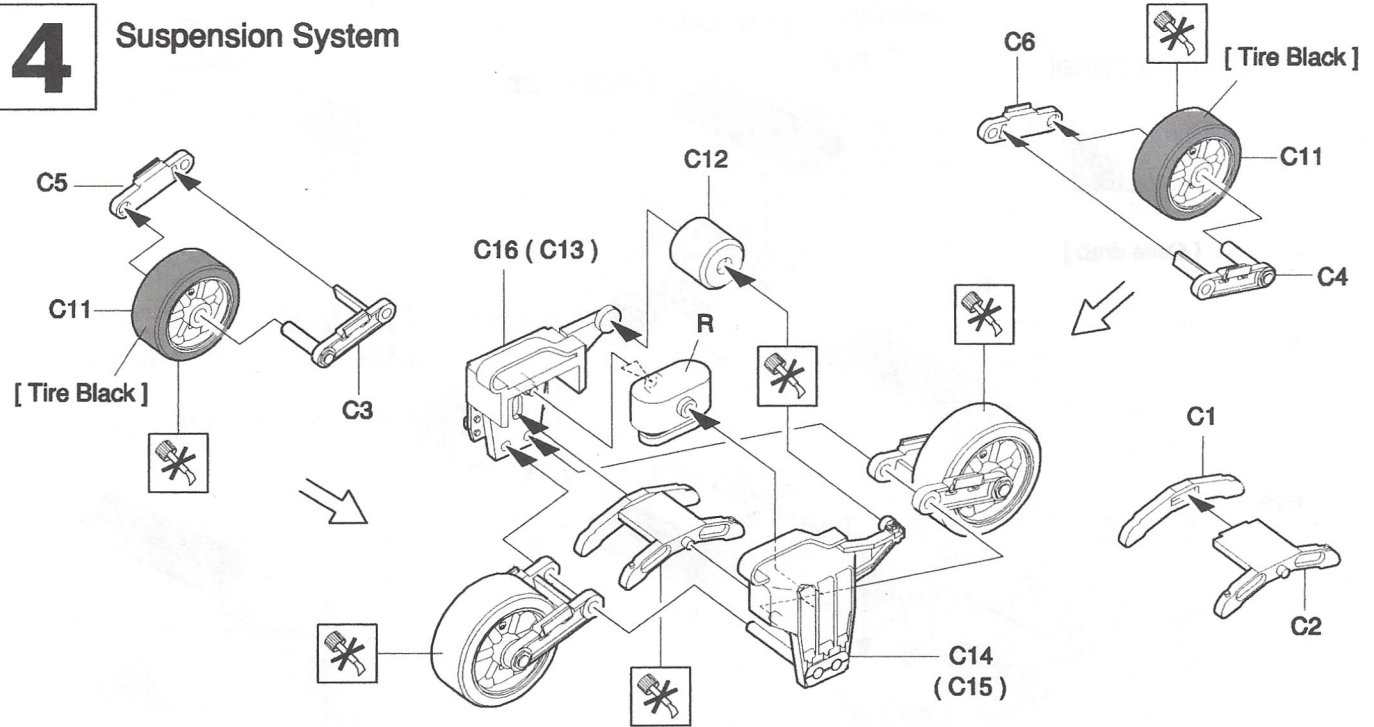

5

Exhaust Pipe

[Red brown]

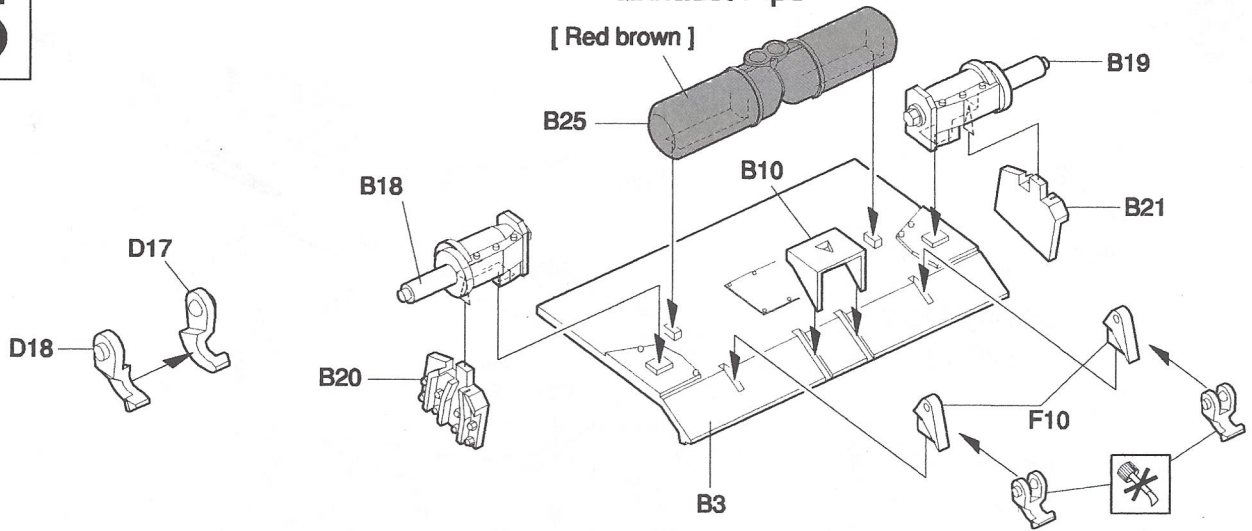

x2

6

Idler Wheel

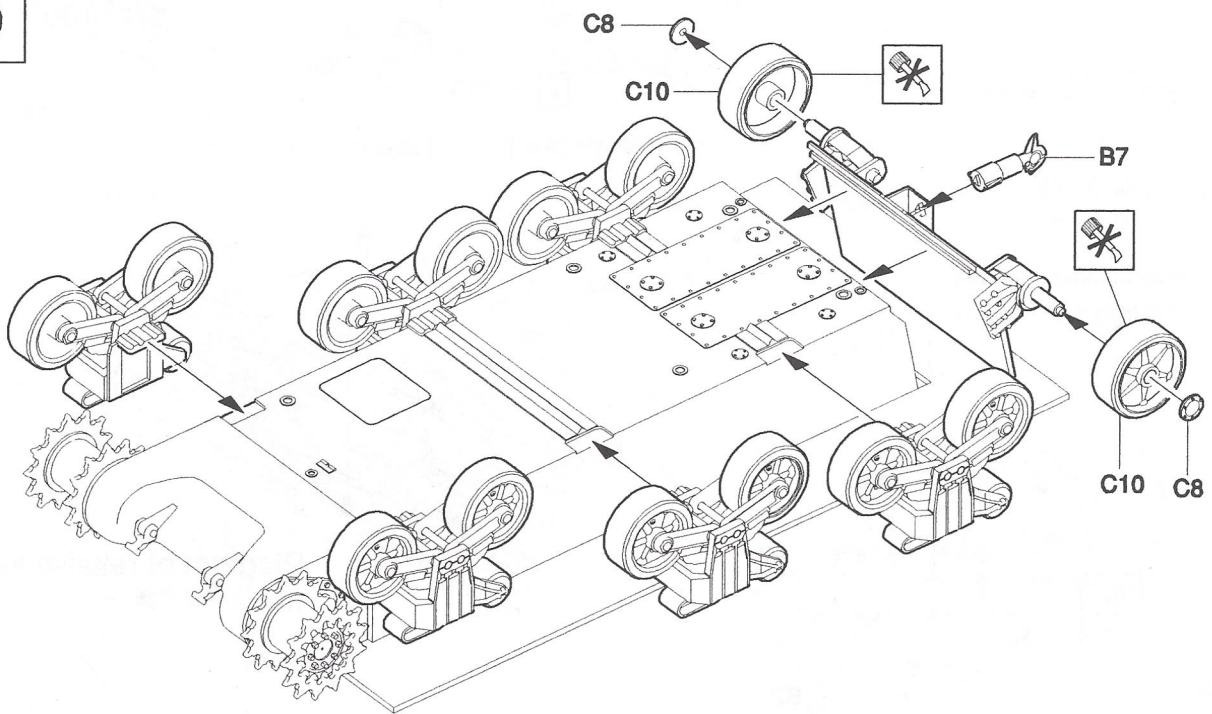

7

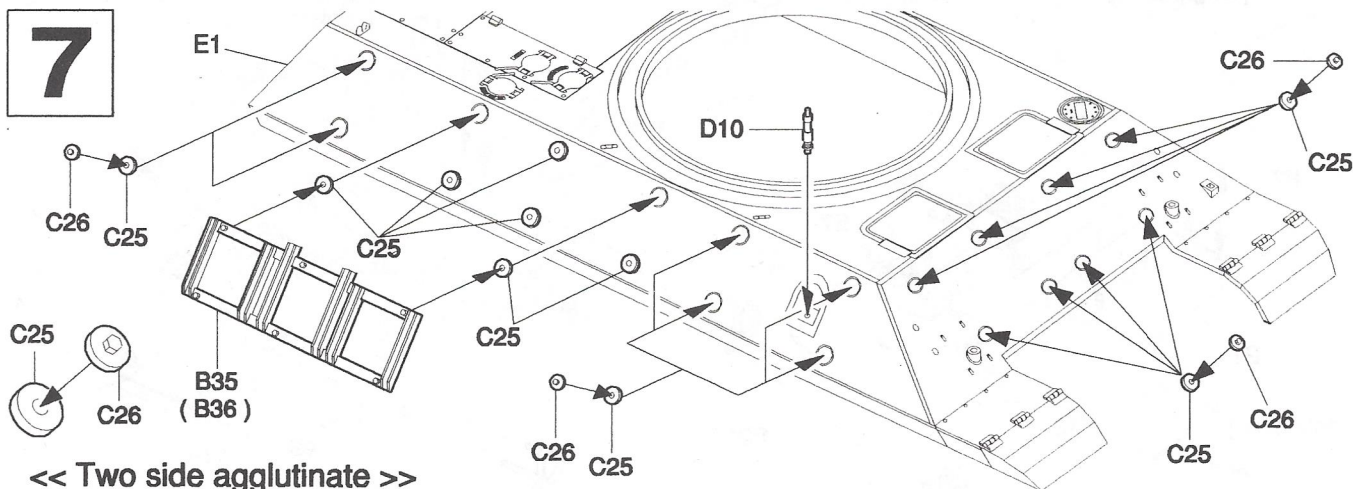

<< Two side agglutinate >>
 << 兩側粘著 >>

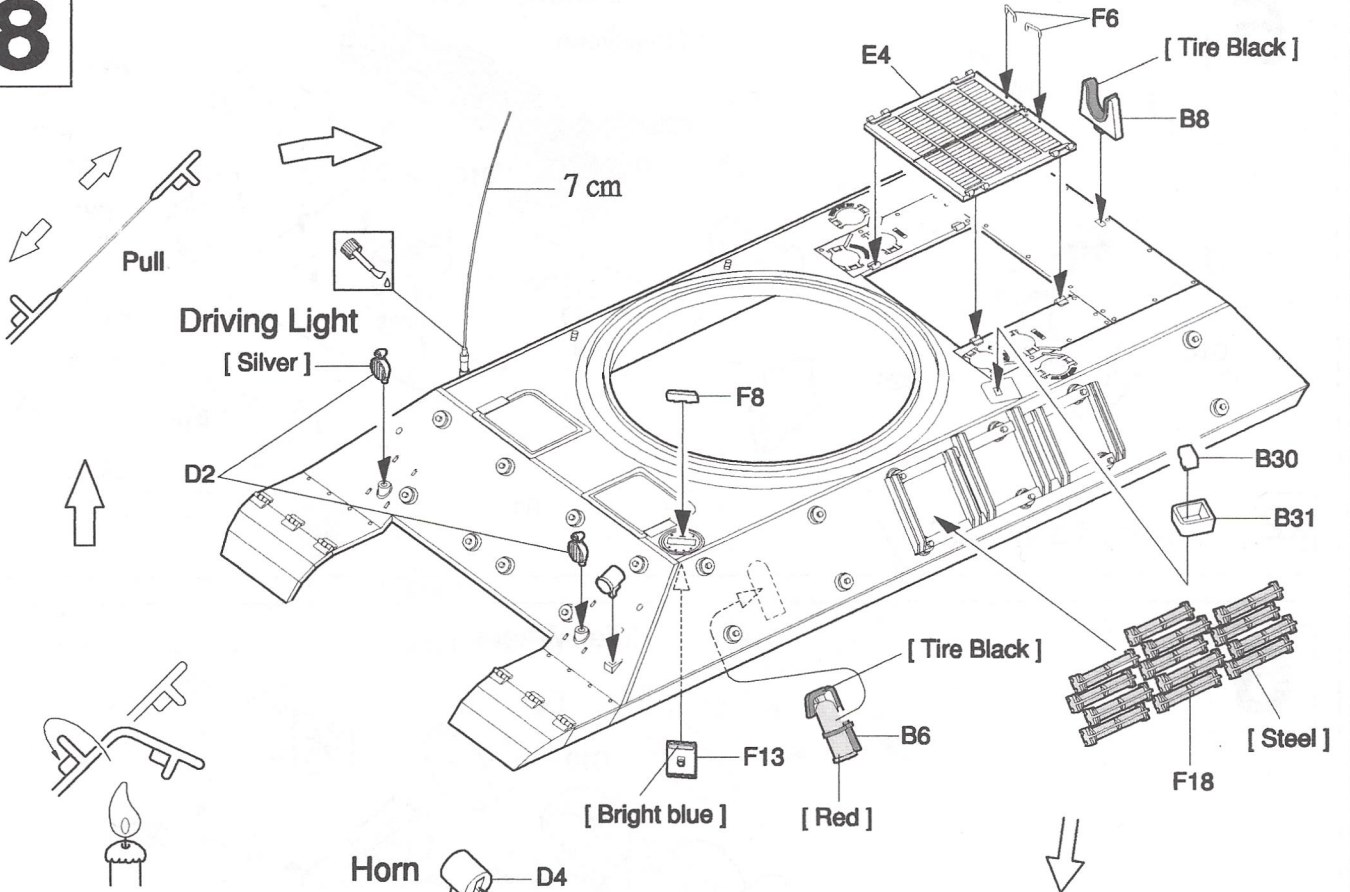

How to make antenna:
天線製作方法

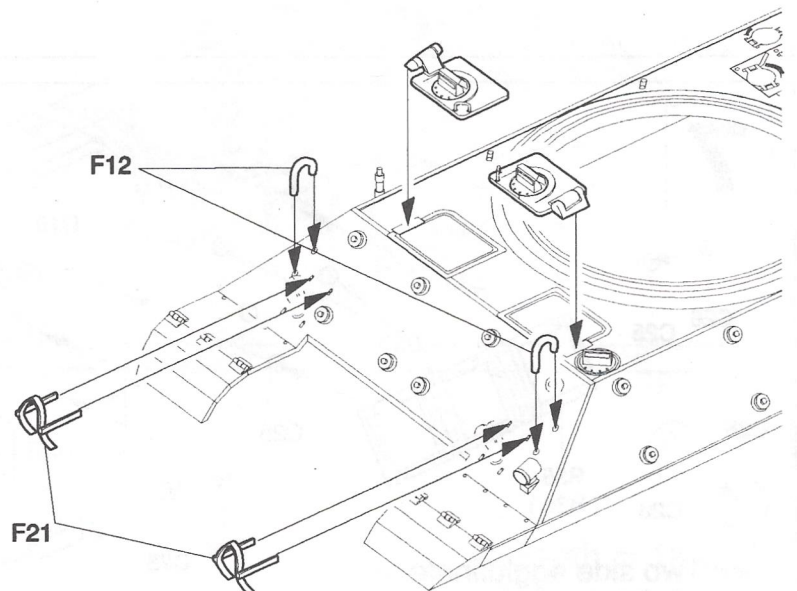
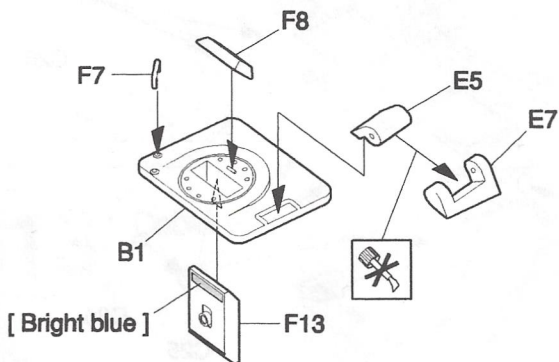
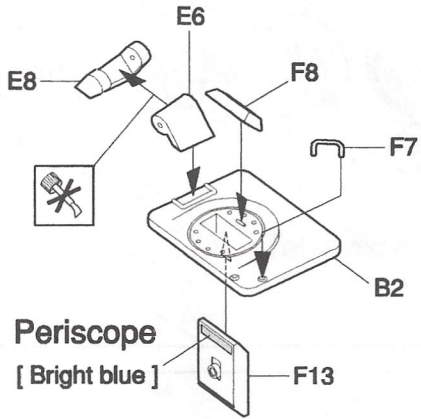
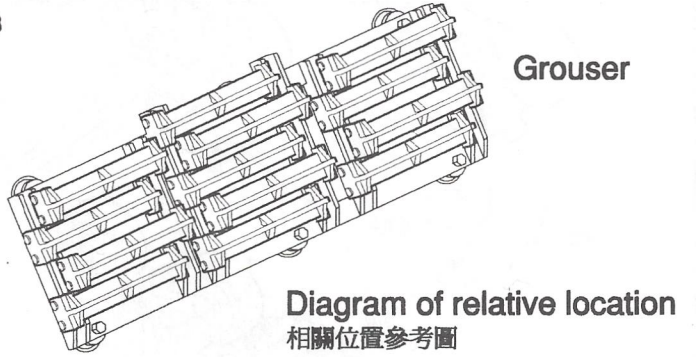

9

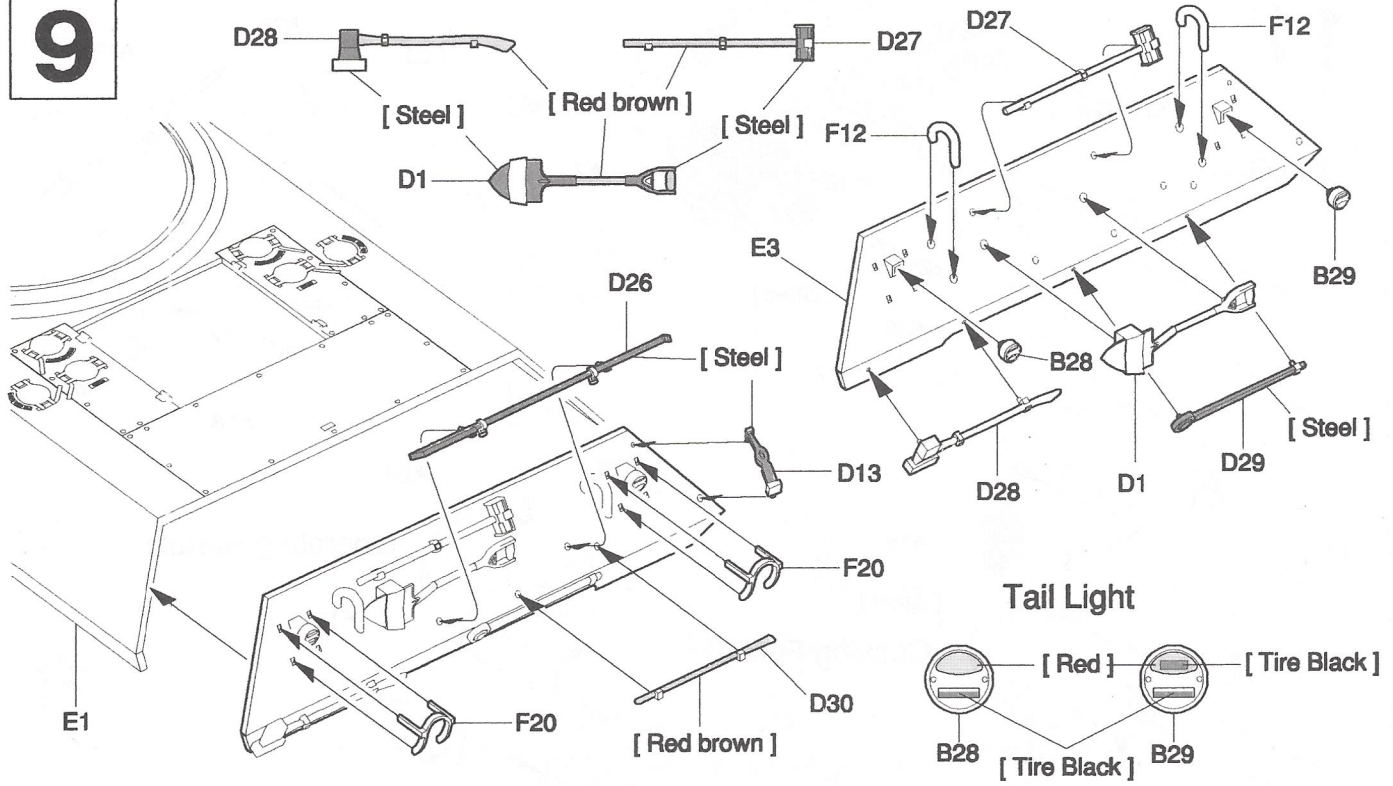

10

Turret

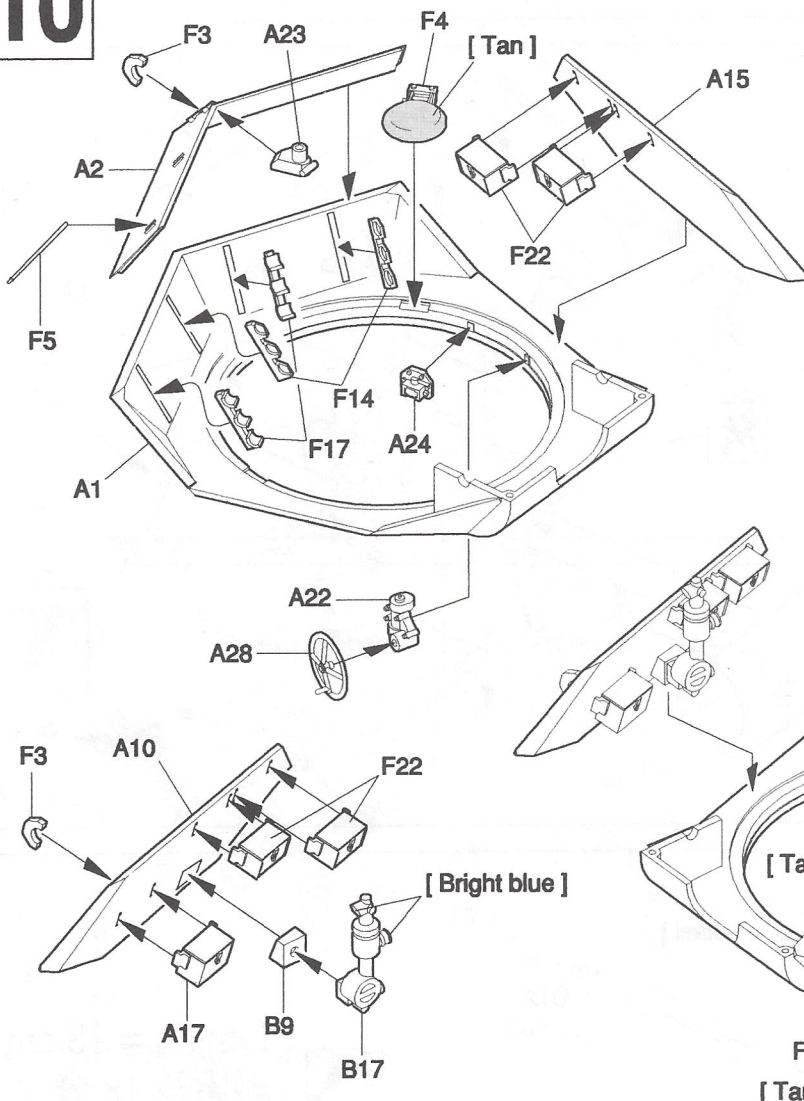

AF35018 U.S.ARMY 76mm & 3inch TANK AMMUNITION

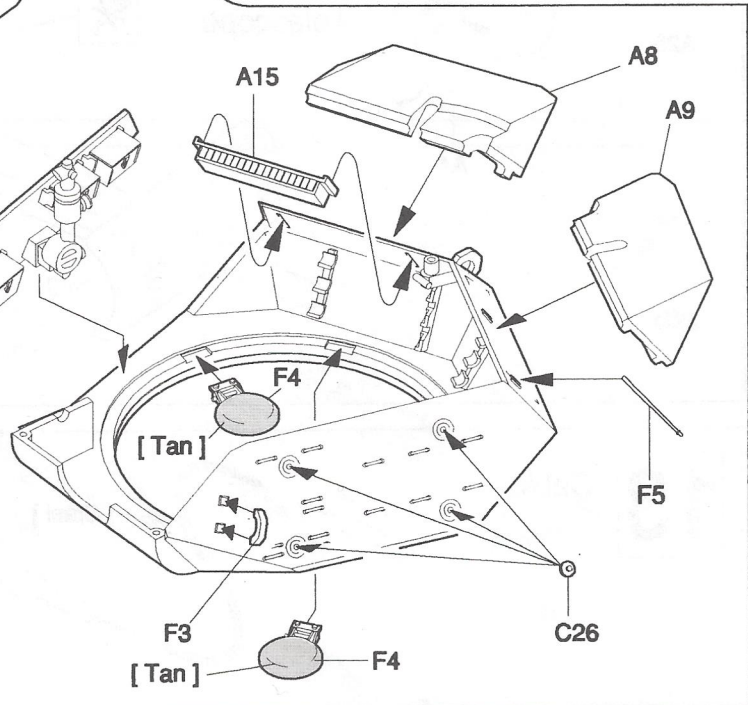
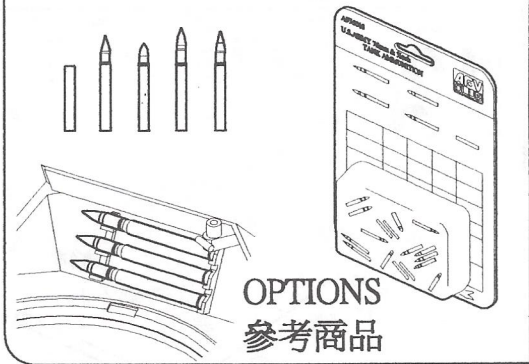

11

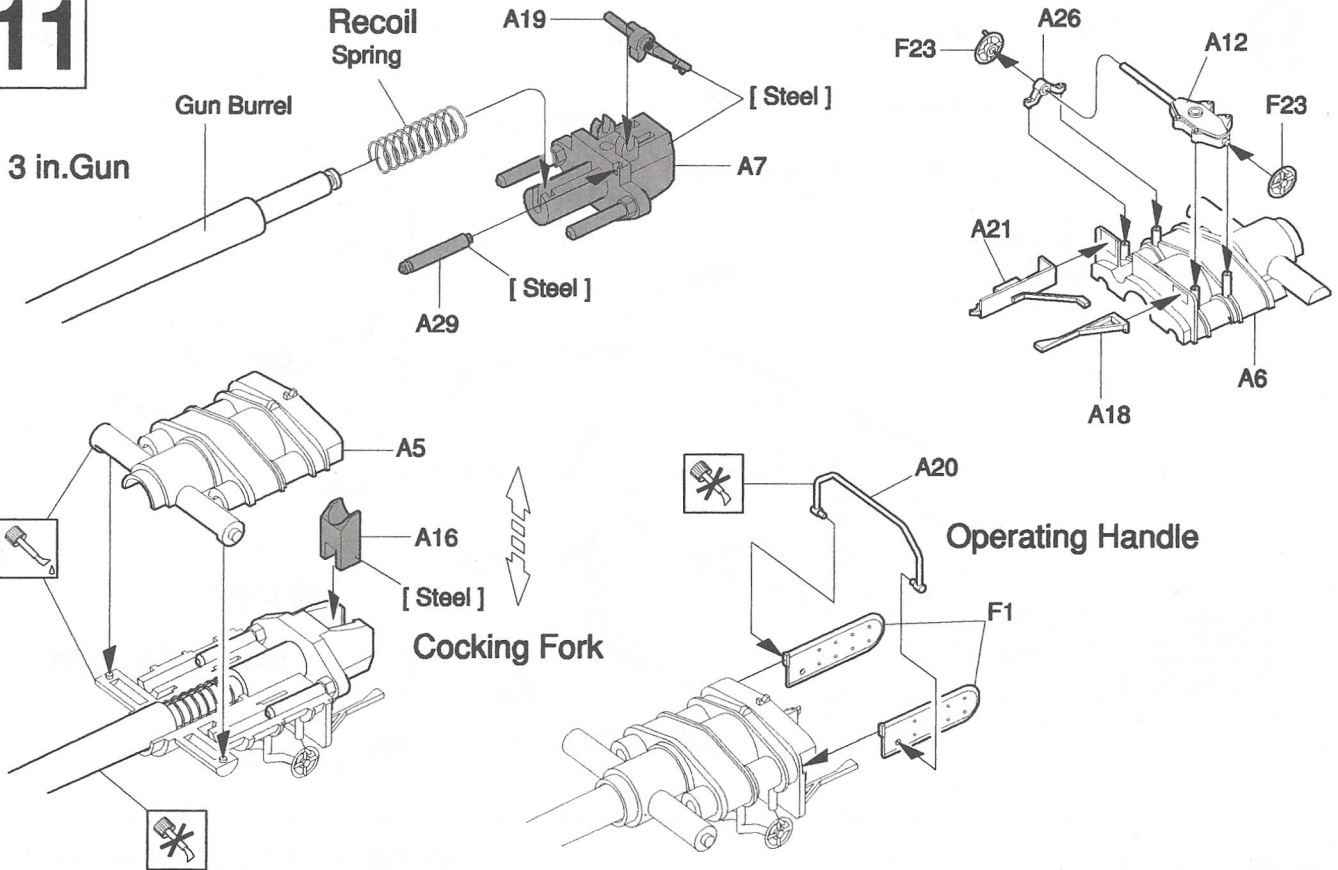

12

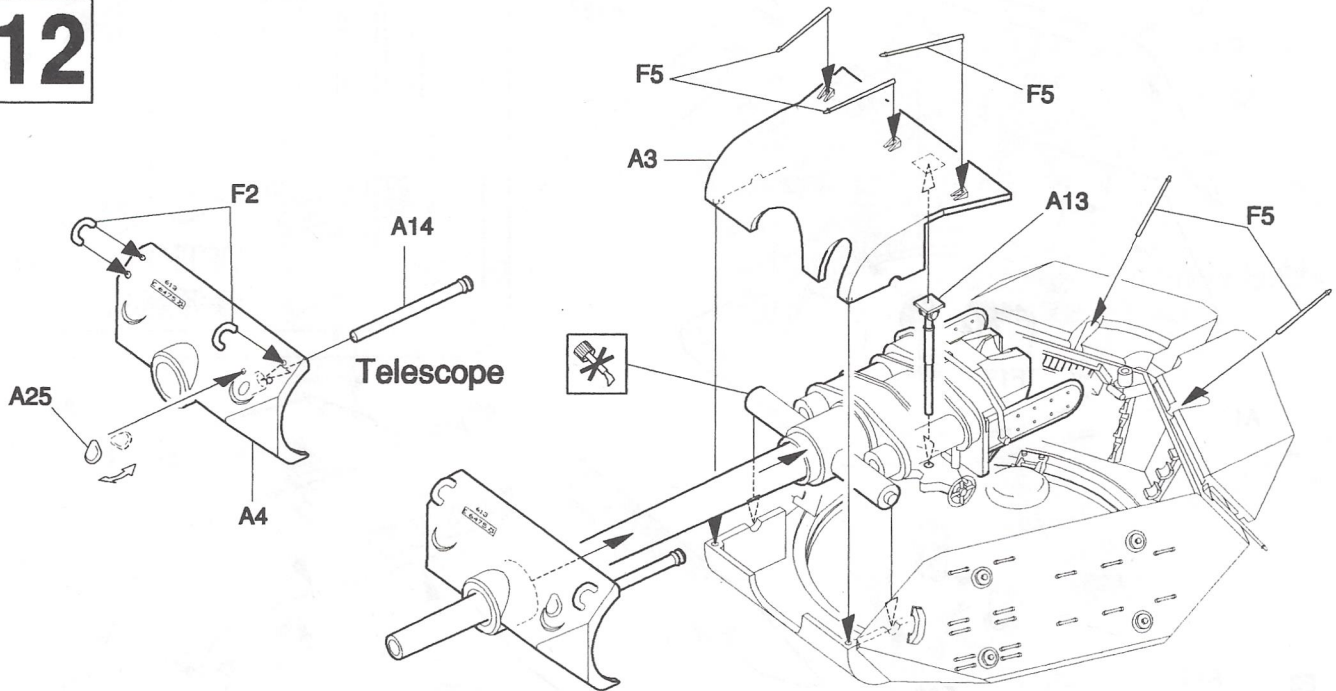

13

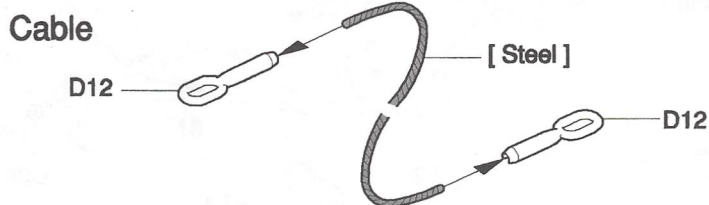

Length = 18 cm
 繩索長 18 公分

14

Cal.50 M2 Maching Gun

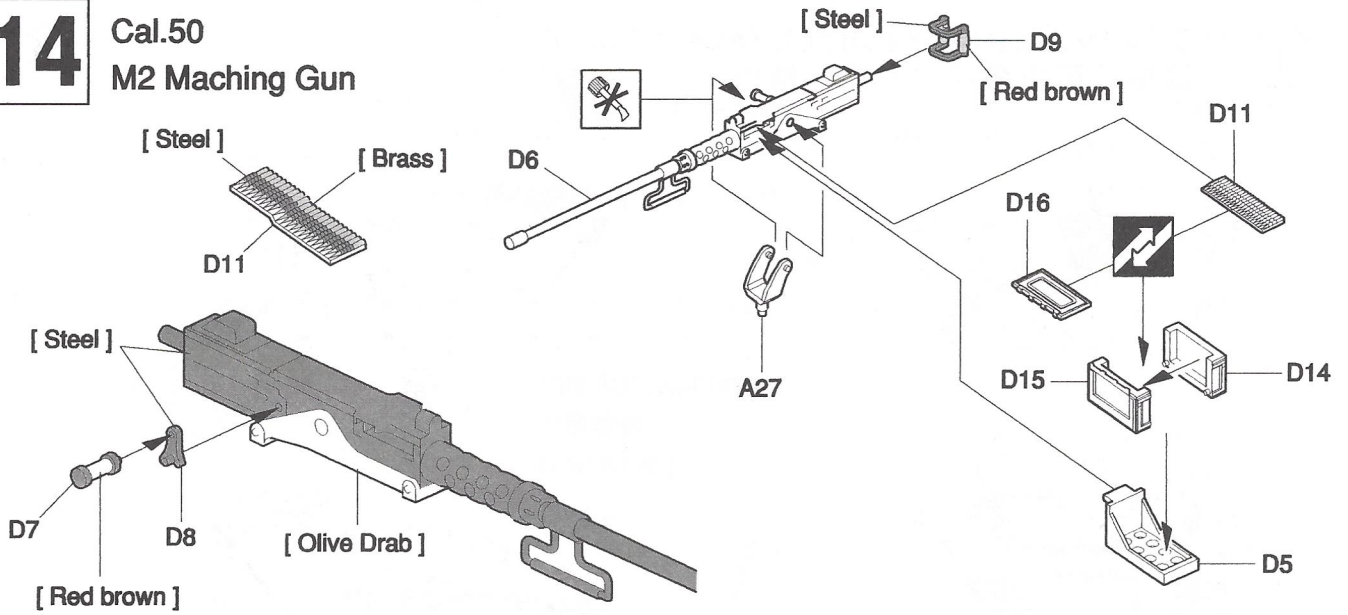

15

AF35026 M4 WORKABLE T51-TRACK

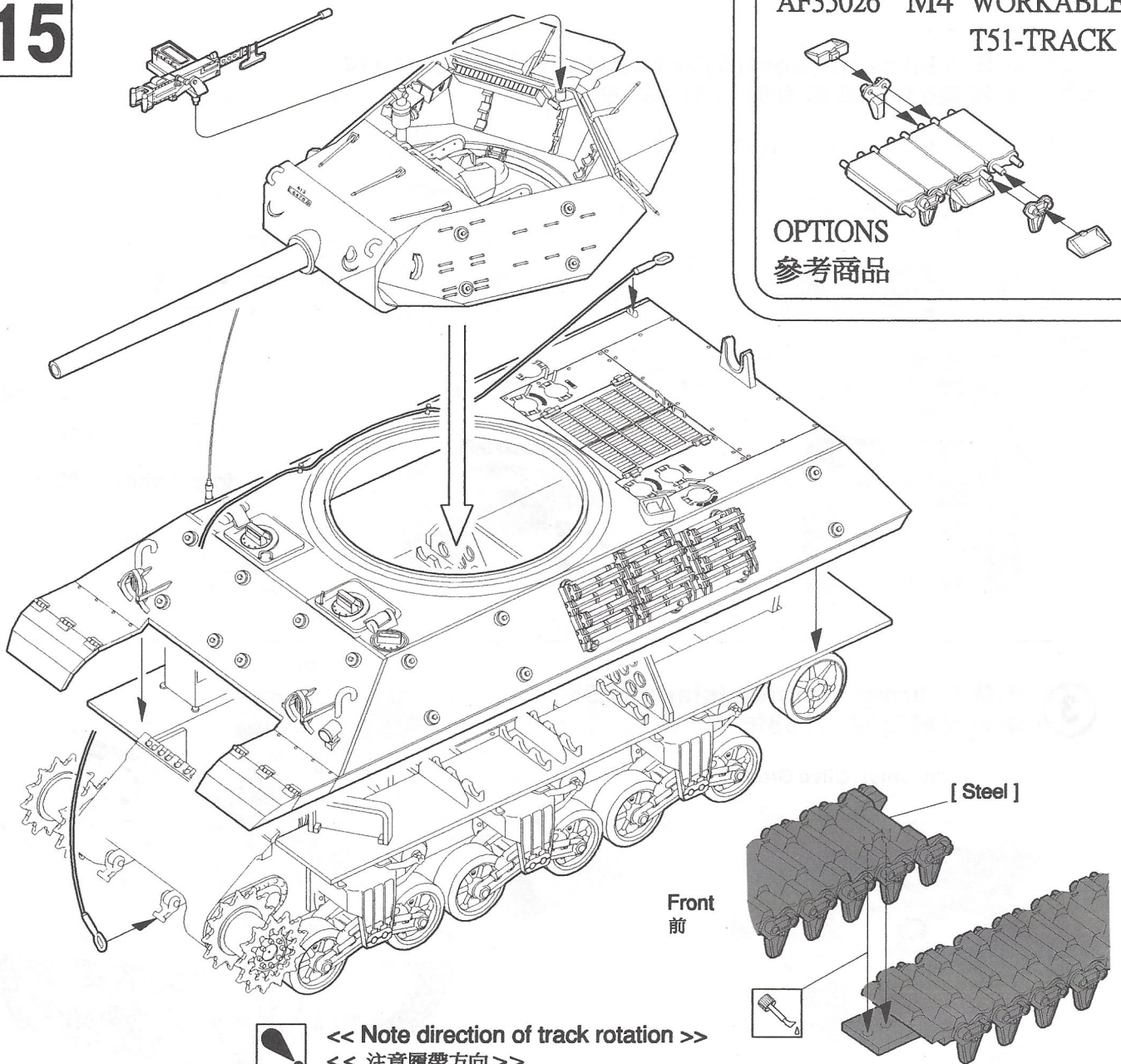

1 U.S. Tank destroyer school. Texas 1943.
美國驅逐戰車學校. 1943年 德州.

 Body Color: Olive Drab

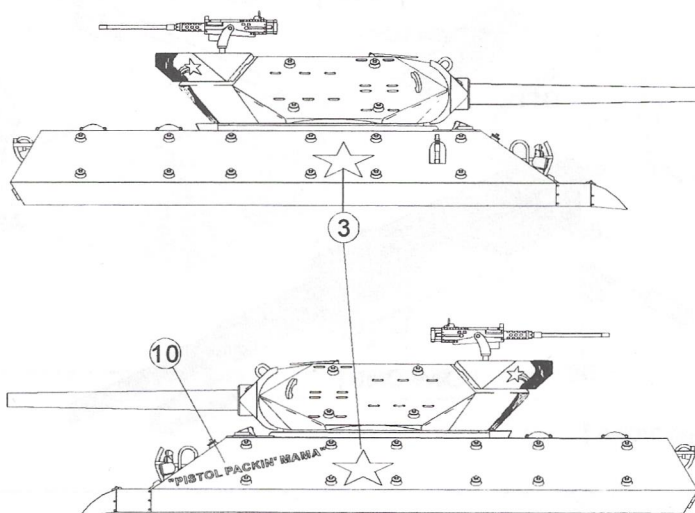
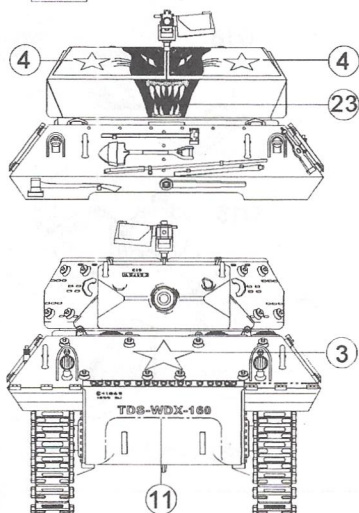

2 U.S. 634th tank destroyer battalion. German 1944.
美國第634驅逐戰車營. 1944年 德國邊境.

 Body Color: Olive Drab

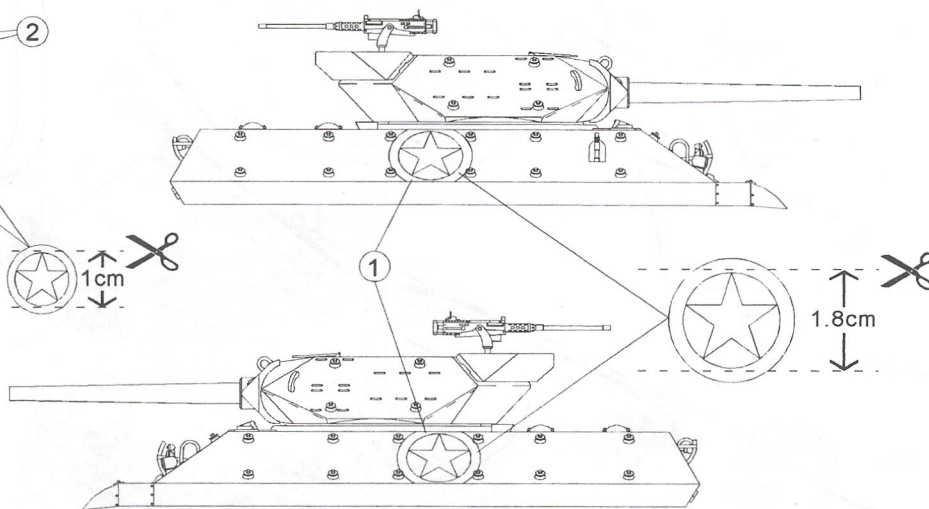
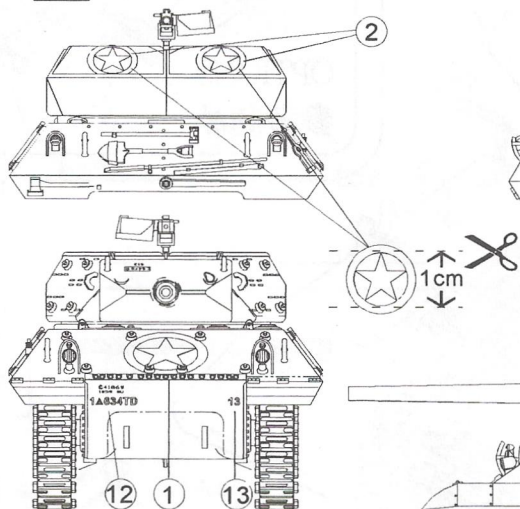

3 R.O.C. army. Jinmen island 1958.
中華民國陸軍. 1958年 金門.

 Body Color: Olive Green

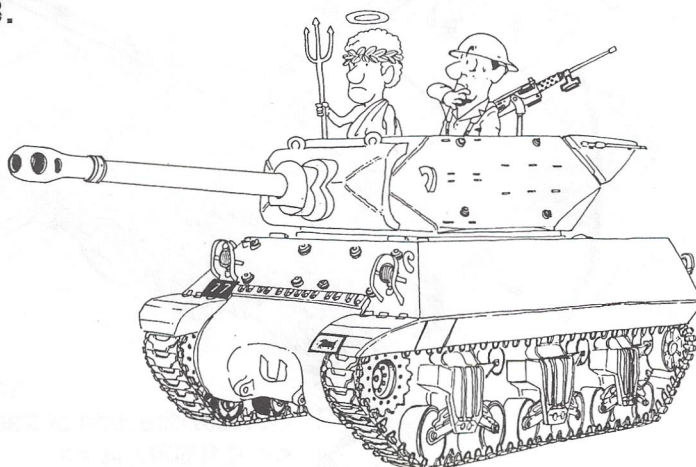
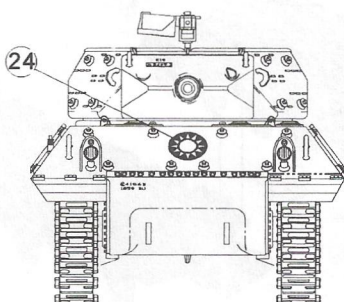

4 French 2nd armored division. France 1944.
自由法國第二裝甲師. 1944年 法國境內.



Body Color: Olive Drab

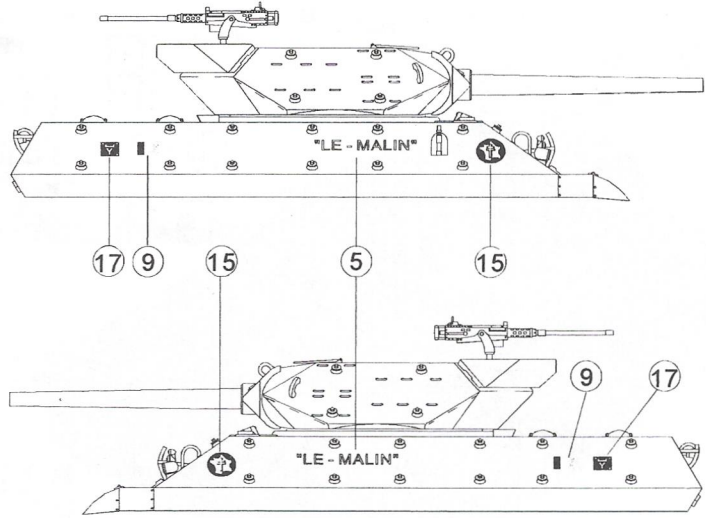
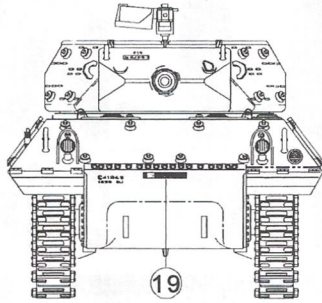

5 France 1945.
自由法國. 1945年 法國境內.



Body Color: Olive Drab

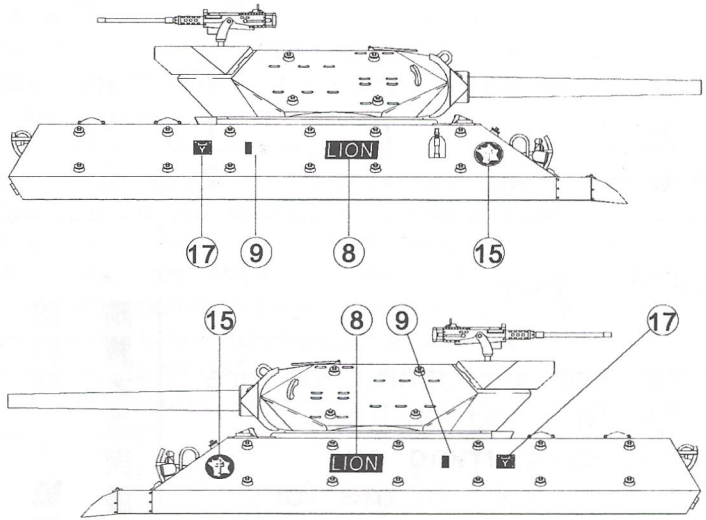
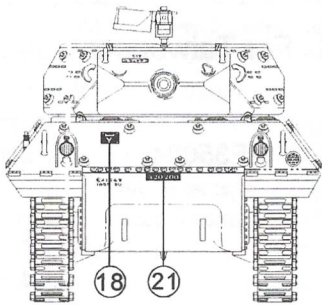

6 France 1945.
自由法國. 1945年 法國境內.



Body Color: Olive Drab

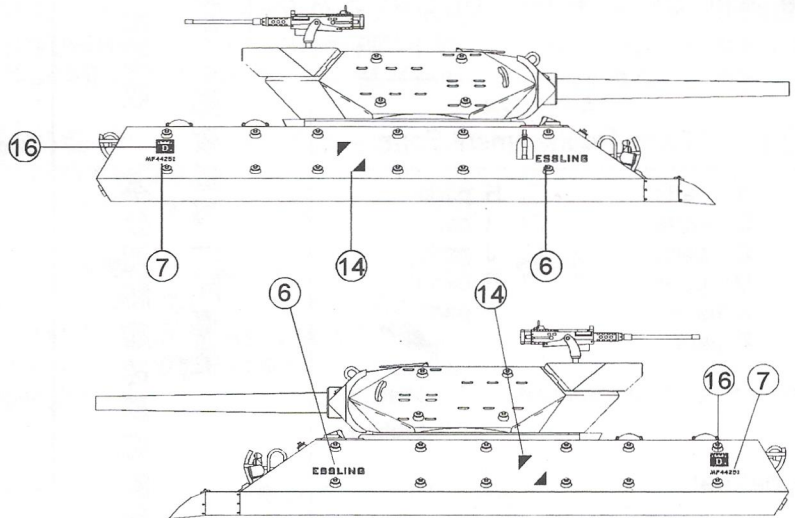
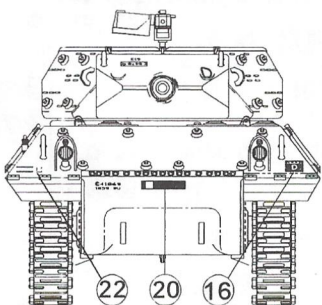

PARTS LIST 零件表

A _____ 1 **D** _____ 1 **H** _____ 1 **R** _____ 1
B _____ 1 **E** _____ 1 **I** _____ 1 **T** _____ 2
C _____ 2 **F** _____ 2 **J** _____ 1

Gun tube 砲管
Spring 彈簧
Cable line 尼龍繩索
Decal 貼紙
Tracks 履帶

Instructions:

If for some reason, you are not fully satisfied or have questions concerning our product; Please use the form provide, and send it to our nearest representative or mail it directly to our office.

We will deal with that A.S.A.P.

限國內使用 . For Taiwanese use only!

		AF35024 Parts Replacement Form	
<input type="checkbox"/> A parts	<input type="checkbox"/> H parts	<input type="checkbox"/> B parts	<input type="checkbox"/> I parts
<input type="checkbox"/> C parts	<input type="checkbox"/> J parts	<input type="checkbox"/> D parts	<input type="checkbox"/> R parts
<input type="checkbox"/> E parts	<input type="checkbox"/> T parts	<input type="checkbox"/> F parts	
Reason for replacement: <input type="checkbox"/> Missing <input type="checkbox"/> broken		Signature: _____	

請將本表與該部品相同金額之郵政匯票一同寄至
 總代理：戰鷹企業 客服部收 本公司將盡速為您處理

	AF35024 零件補充申請表	申請人 姓 地 電 名 址 話 : : :
<input type="checkbox"/> A 部品零件 ----- NT\$ 200 <input type="checkbox"/> B 部品零件 ----- NT\$ 150 <input type="checkbox"/> C 部品零件 ----- NT\$ 250 <input type="checkbox"/> D 部品零件 ----- NT\$ 60 <input type="checkbox"/> E 部品零件 ----- NT\$ 280 <input type="checkbox"/> F 部品零件 ----- NT\$ 160 <input type="checkbox"/> H 部品零件 ----- NT\$ 30 <input type="checkbox"/> I 部品零件 ----- NT\$ 30 <input type="checkbox"/> J 部品零件 ----- NT\$ 120 <input type="checkbox"/> R 部品零件 ----- NT\$ 30 <input type="checkbox"/> T 部品零件 ----- NT\$ 160 + 郵寄費 ----- NT\$ 40 (請填) 總計 NT\$ _____		
零件補充原因: (請於 <input type="checkbox"/> 打✓) . 原包裝即 <input type="checkbox"/> 遺失或 <input type="checkbox"/> 毀損, . 製作途中 <input type="checkbox"/> 遺失或 <input type="checkbox"/> 毀損, . <input type="checkbox"/> 補充多餘零件, . 其它原因 _____		