

F-8E Crusader MiG Masters Pt.I

- 1** F-8E BuNo 150924 NP 103, VF-211, USS Hancock, 1966.
This aircraft was used by Cdr Harold L Marr (CO of VF-211) who scored first Crusader's combat kill the MiG-17 on 12 June 1966. Later was this Crusader shot down by flak, while serving as AH 201 of VF-162. The pilot Lt. R D Leach was successfully recovered.

F-8E BuNo 150924 NP 103, VF-211, USS Hancock, 1966.
Na tomto stroji létal Cdr Harold L Marr velící důstojník VF-211. V jeho kokpitu dosáhl 12. června 1966 prvního bojového sestřelu na Crusaderu a to MiG-17. Později během služby u VF-162 jako AH 201 byl tento letoun sestřelen flakem. Jeho pilot, Lt. R D Leach, byl úspěšně zachráněn.

- 2** F-8E BuNo 149159 AH 210, VF-162, USS Oriskany, 1966.
This aircraft was flown by legendary Dick Bellingier. In this jet he scored the Navy's first MiG-21 kill on 9 October 1966. Although wearing standard squadron markings, this aircraft did not carry the Snoopy drawing on the fin as usually seen on other machines of VF-162.

F-8E BuNo 149159 AH 210, VF-162, USS Oriskany, 1966.
Pilotem tohoto stroje byl legendární Dick Bellingier. 12. října 1966 v kokpitu této „Roury“ sestřelil MiG-21, který byl zároveň prvním sestřelem MiGu-21 pro námořnictvo. Ačkoliv je tento letoun vyzdoben všemi znaky jednotky, nemá na ocasní ploše kresbu Snoopyho jako ostatní stroje VF-162.

- 3** F-8E BuNo 150900 NF 209, VF-53, USS Hancock, 1967.
Renumbered NF 209 was aboard USS Hancock during the busy 1967 war cruise. Later reassigned to VF-211 where it earned a brief moment of fame as an unofficial MiG-Killer. This Crusader was long living veteran serving since 1965 until 1972.

F-8E BuNo 150900 NF 209, VF-53, USS Hancock, 1967.
Přechíslovaný NF 209 sloužil z paluby USS Hancock v průběhu rušného válečného roku 1967. Později byl stroj předán k VF-211 u které si prožil krátký okamžik slávy jako neoficiální MiG-Killer. Tento Crusader byl veteránem sloužícím na palubách od roku 1965 do roku 1972.

All aircraft had standard camouflage of that era, FS 16440 on upper surfaces and FS 17875 on lower surfaces.

NOTE: Remove the tail ECM antenna fairing for aircraft #2







References :

- 1) Peter Mersky, F-8 Crusader Units Of The Vietnam War, Osprey Publishing
- 2) Vought F-8 Crusader, FAOW #1
- 3) F-8 In Action #70

Suggested Kit :

Hasegawa - F-8E Crusader

Camouflage colors :

	Barva	FS	Gunze Mr. Color		Barva	FS	Gunze Mr. Color
	Gray	FS 16440	C 315		Burnt metal		*
	White	FS 17875	C 316		Silver	FS 17178	C 8
	Black	FS 37038	C 2		* C 8 50% + C 28 50%		

NOTE: Not measured for Revell/ Monogram kit

DEAD Design

AVI PRINT, Svárov 922, 755 01 Vsetín, Czech Republic, www.aviprint.cz

1 F-8E VF-211, USS Hancoc, 1966

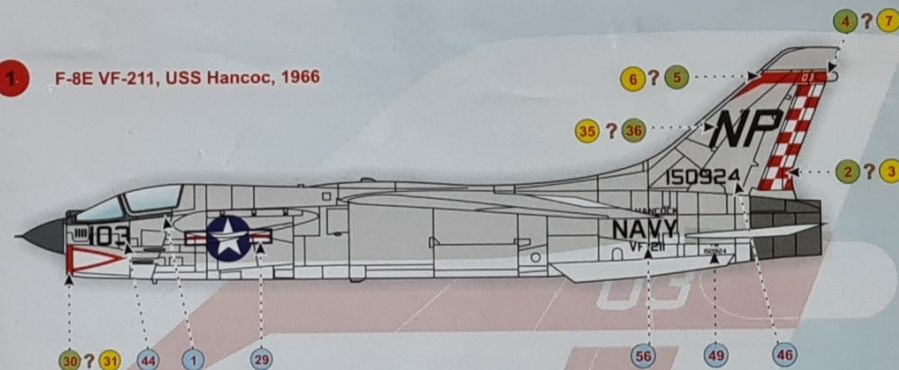

2 F-8E VF-162, USS Oriskany, 1966

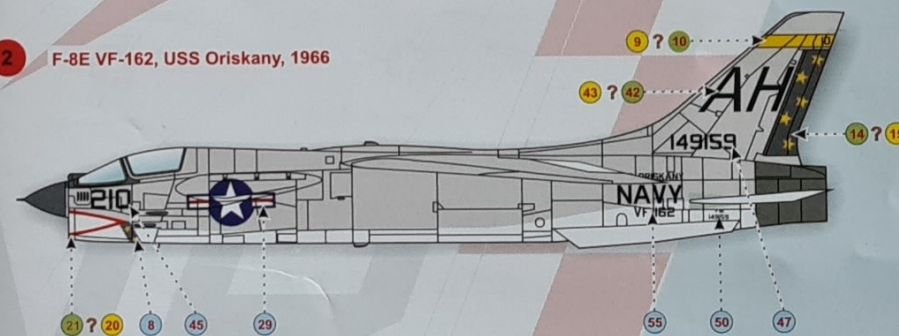

3 F-8E VF-53, USS Hancock, 1967

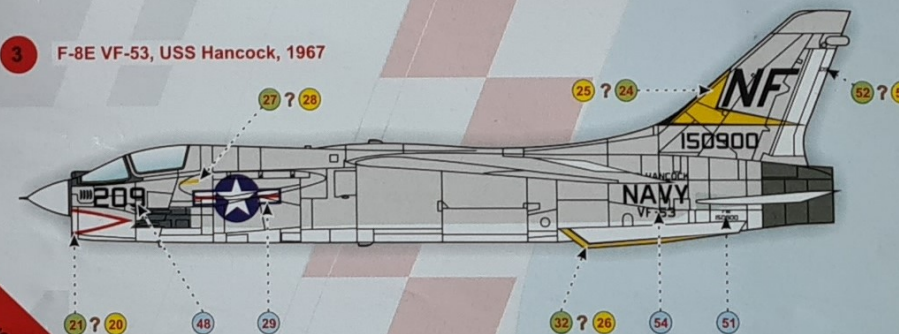

● Left side

● Right side

ENGLISH - CZECH TEXT

48 006

F-8E Crusader MiG Masters Pt.I

1

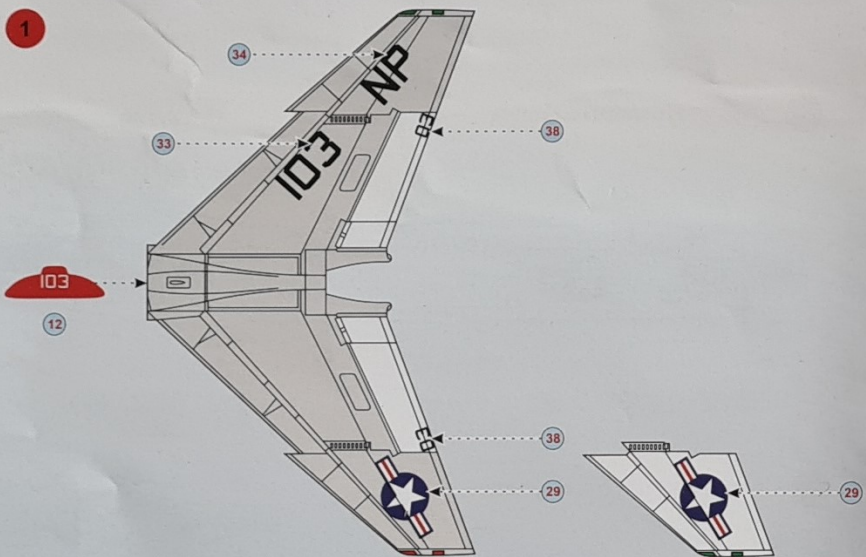

3

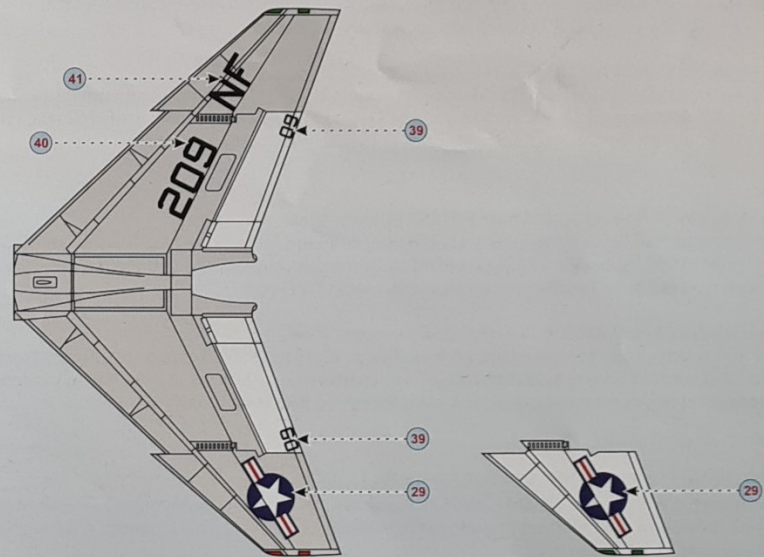

2

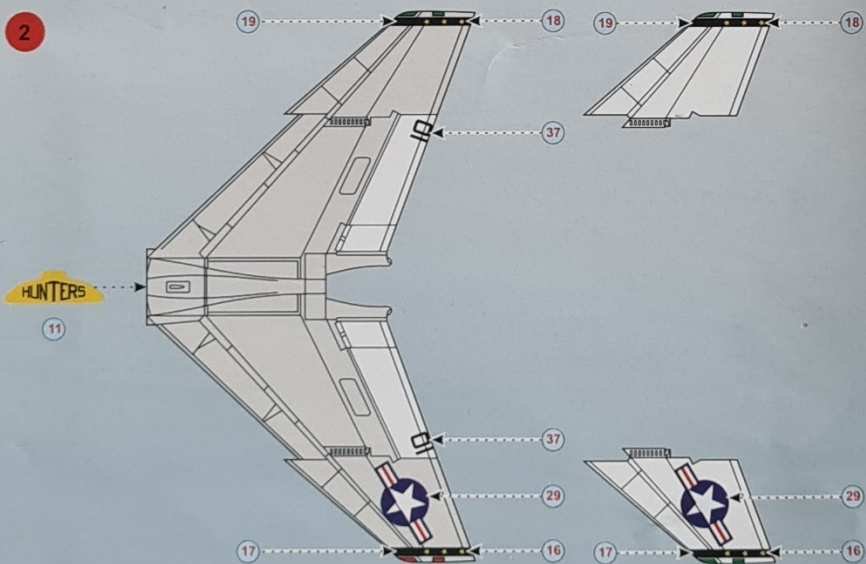

COMMON TO ALL AIRCRAFT

