

# ERTL®



# F-100 D SUPER SABRE

No. 8557

1/72 Scale

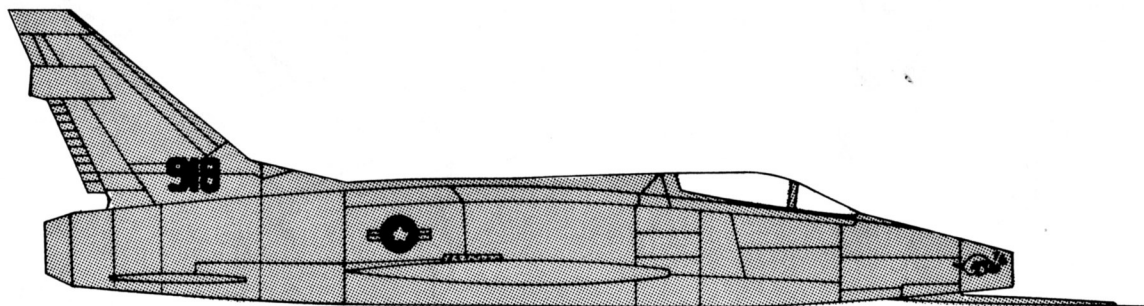

## History

When the Air Force began looking for a successor to the popular F86 Sabre in 1949, development began on what was to become one of the most capable weapons in the United States arsenal. Because it was supposed to feature 45° sweep back wings, the working title of the project during the design stage was "Sabre 45".

By the time the first prototype rolled out of the assembly plant its name had already been changed to the YF-100 A (AF 52-5754). Although it demonstrated that it was capable of exceeding the speed of sound during test flights, there were some design flaws that rendered the craft virtually uncontrollable while in certain positions during flight. These faults, due to the then unknown problem of aerodynamic inertia, were corrected by modifying the profile of some external surfaces. In November, 1953, although too late to take part in the Korean conflict, the F-100 A replaced the F-86 as the standard daytime fighter of the United States Air Force.

Later versions were converted into fighter-bombers, and the F-100 C and D models were enormously popular, especially with their crews. They were fast, well armed, and exceptionally maneuverable. In fact, they handled so well that for many years they were used by the famous "Skyblazers" and "Thunderbird" aerobatic teams (Ertl-Esci Kit 8425 - F100 D Thunderbirds, 1/48 scale).

Since 1956, the F100 Super Sabre has taken part in every war time operation the U.S. has been engaged in, seeing action in South East Asia as early as June, 1964.

The F104 D has also been a popular export, having served in the Air Forces of such countries as Taiwan, Turkey, Denmark, and France. Having been officially retired from active duty in the U.S.A.F. in 1972, the F100 D Super Sabre will long be remembered as an excellent and versatile attack plane.

## Histoire

La North American, après avoir remporté un succès remarquable avec son F-86 Sabre ( Sabre ) entamait dès 1949, dans le cadre d'une programmation clairvoyante, des études en vue de l'élaboration de son successeur. Provisoirement, le projet recut le nom de Sabre 45 (du fait qu'il était caractérisé par le dessin d'une aile en forme de fleche de 45°) et prévoyait un nouveau chasseur destiné à avoir la suprématie de l'air, équipé de quatre canons General Motors M39 de 20 mm. et muni d'une prise d'air en "bouche de requin" susceptible d'améliorer davantage encore la visibilité déjà excellente du F-86.

Le prototype YF-100 A (AF 52-5754) fut le premier chasseur américain de la Century Series ( Série du Siècle ou mieux, classe 100). Il devait aussitôt offrir des performances remarquables, dépassant la vitesse du son en vol horizontal et ne présentant que le seul inconvénient d'une incontrôlabilité dans certaines attitudes du fait d'un phénomène d'inertie aérodynamique alors inconnu. Il fut pallié à cet inconvénient en modifiant le profil de certaines surfaces et à partir de Novembre 1953 (bien que trop tard pour intervenir dans la guerre de Corée) le F-100 A devenait le chasseur de jour standard de l'USAF, remplaçant le F-86 E.

À la version F-100 A succédait la version B pour un chasseur bombardier tout temps bi-siègle. Cette version, reconçue F-107 ne devait cependant jamais dépasser le stade de prototype.

Ce furent par contre, dans la ligne chasseur bombardier, les modèles F-100 C et D qui remportèrent des succès considérables.

Le F-100 D connu de ses équipages comme Hun (hun et également l'abréviation de Hundred: 100) entra en service dès le début de 1956 et devait depuis lors participer à toutes les opérations militaires qui virent engagées les forces américaines, accomplissant les premières interventions dans le sud-est asiatique à partir de Juin 1964. Le F-100 D, dont il fut construit 1274 appareils, fut suivi par le F-100 F, bi-place convenant aussi bien à l'entraînement qu'aux missions spéciales (333 appareils).

De plus le Super Sabre trouvait place dans les Forces Aériennes de Taiwan, de la Turquie, du Danemark et de la France. Cette dernière fut la première à le mettre à la retraite en 1977 (l'USAF l'avait déjà remplacé dès 1972).

Enfin, le F-100 eut également la possibilité d'illustrer ses capacités dans le conflit vietnamien où il se distingua par la qualité aussi exceptionnelle que multiple de son assaut.

# 1

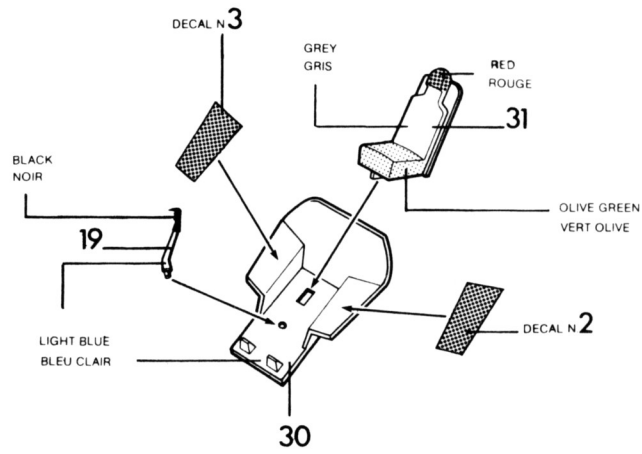

# 2

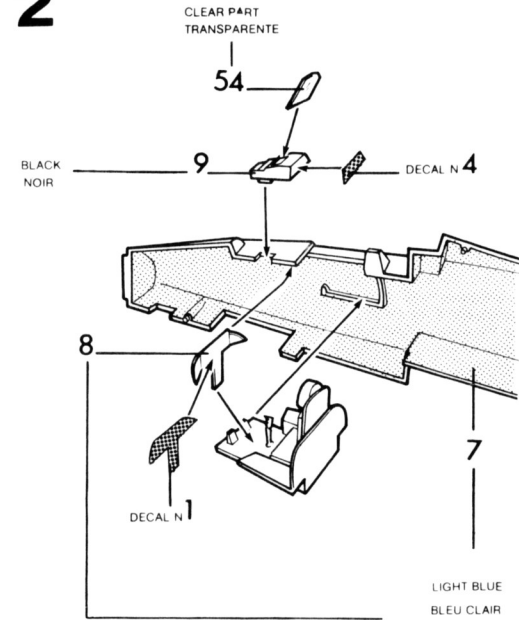

# 3

A version - USAF - 481 T.F.S.  
 B version - ANG - 184 T.F.S.  
 C version - ARMEE DE L'AIR  
 D version - KONGELIGE DANSKE  
 FLYVEVABNET

BLADE AERIAL VHF  
 CUT AS INDICATED (FOLLOWING DASHES)  
 COUPER (V' LIGNE EN POINTILLE)

for A-C-D versions  
 only.

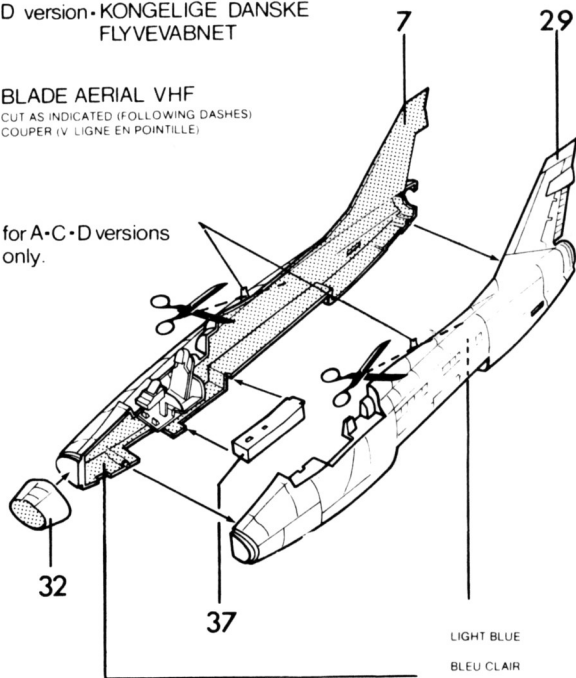

# 4

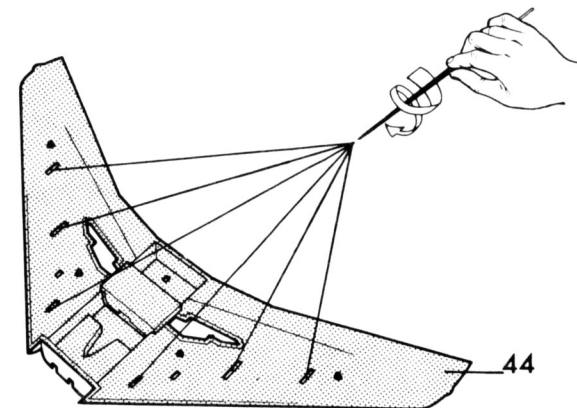

# 5

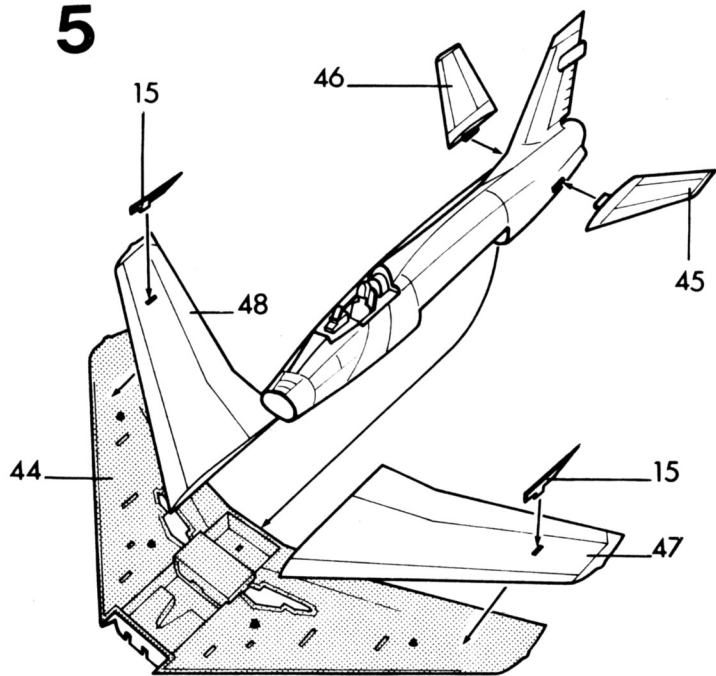

# 6

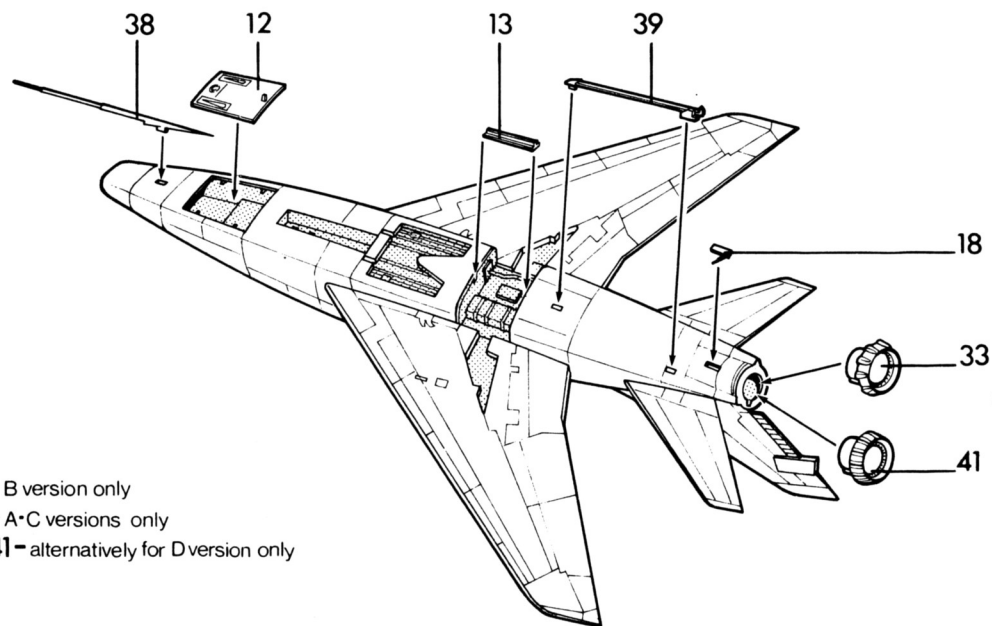

piece 33 - for B version only  
 piece 41 - for A-C versions only  
 pieces 33 or 41 - alternatively for D version only

BURNISHED METAL  
 METAL BRUNI

# 7

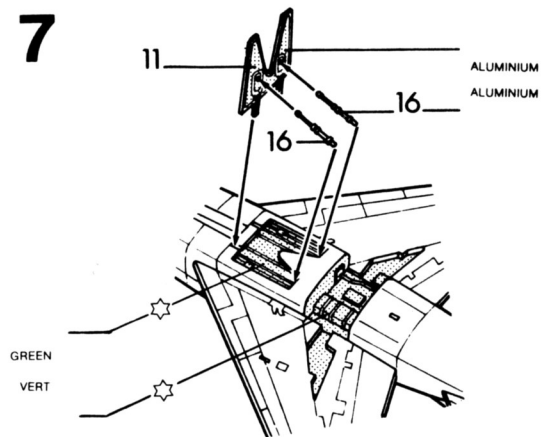

OLIVE GREEN  
 VERT OLIVE

☆-11- for D version only

# 8

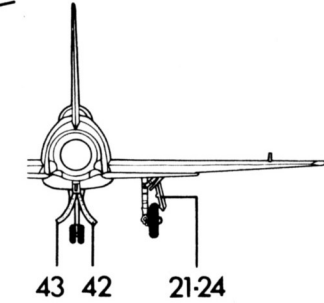
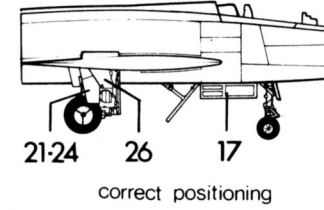
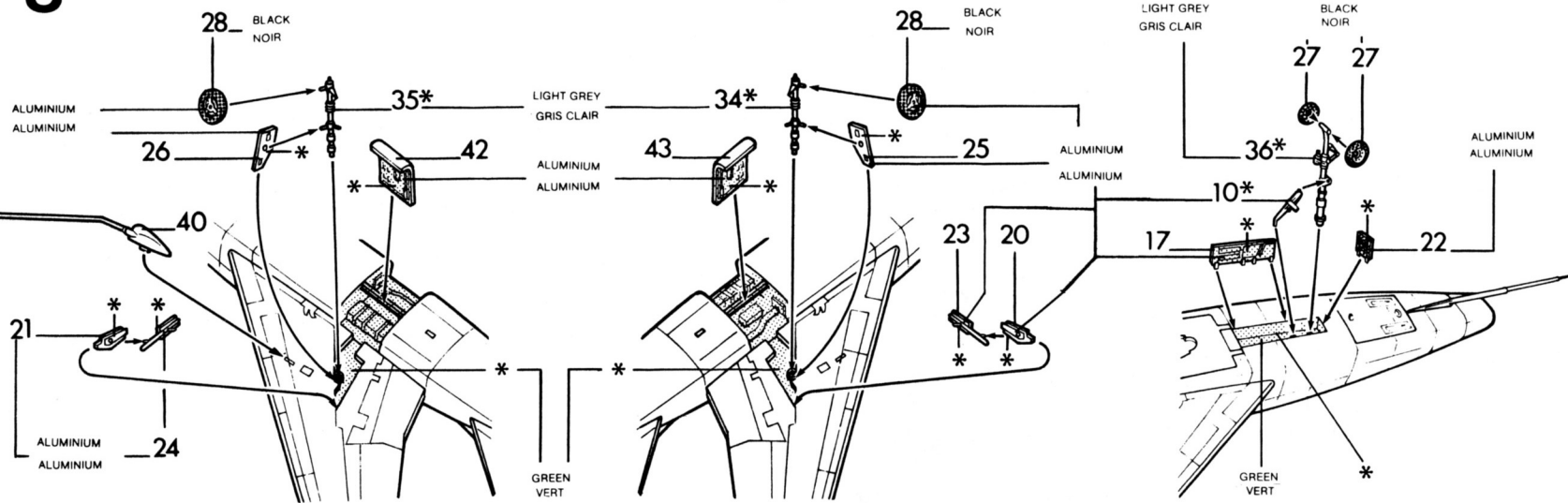

piece 40 - for A-B versions only  
and C version optional

OLIVE GREEN VERT OLIVE -\*- for D version only

# 9

WHITE BLANC -1-2-6

for A version only  
SILVER ARGENT -3-4-☆

for B version only  
LIGHT GREY GRIS CLAIR -3-4-☆

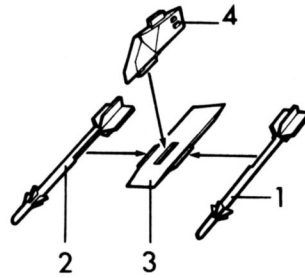

A

alternative for plate A  
for A-D versions only

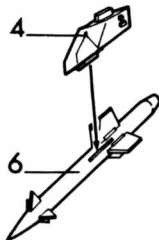

B

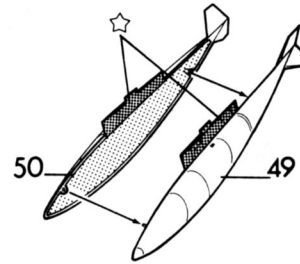

C

for C version only  
OLIVE GREEN VERT OLIVE ☆

for C version only  
10% BLUE BLEU + 90% WHITE BLANC -3-4

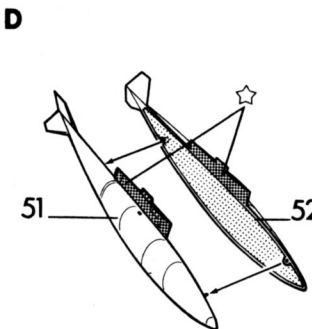

D

for D version only  
OLIVE GREEN VERT OLIVE ☆-3-4

1

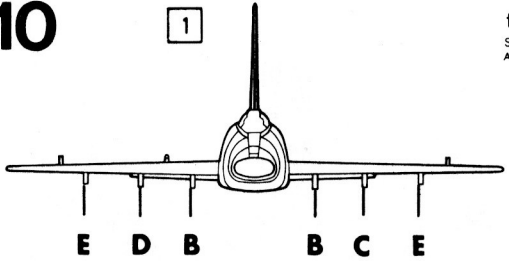

for A version only  
 SILVER -5-14  
 ARGENT

for B version only  
 LIGHT GREY  
 GRIS CLAIR

1

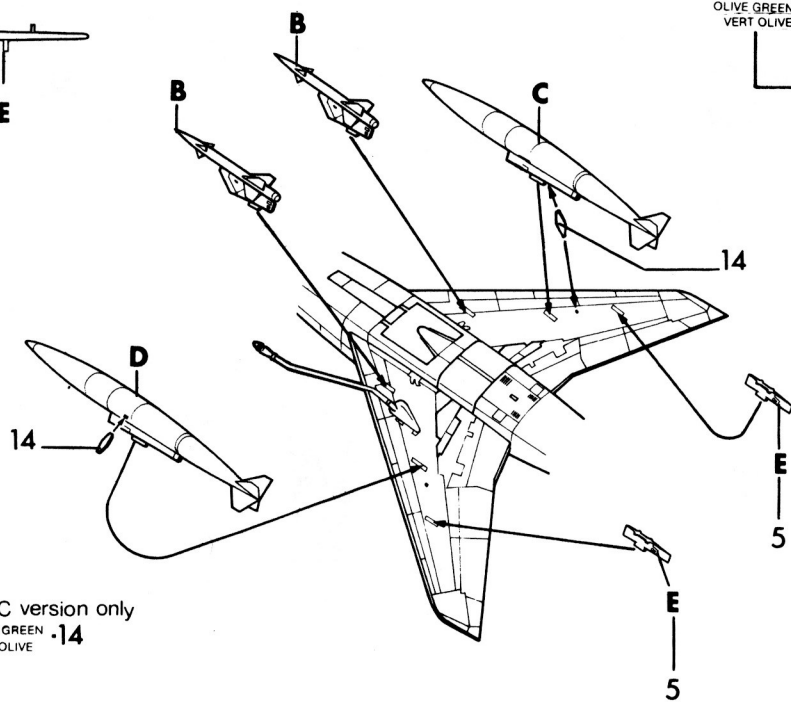

for C version only  
 OLIVE GREEN -14  
 VERT OLIVE

OLIVE GREEN -14 for B version only  
 VERT OLIVE  
 5-14 for D version only

2

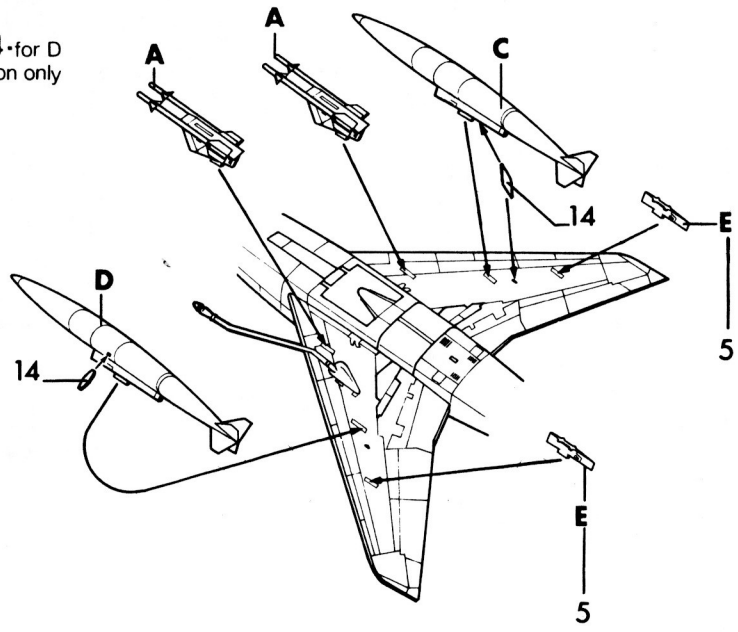

2

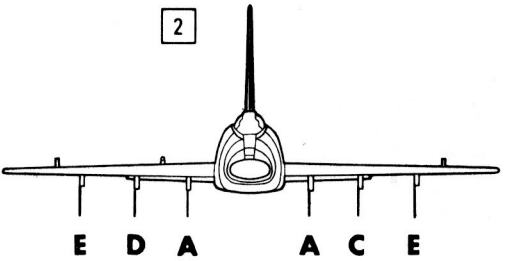

for C version only  
 10% BLUE BLEU + 90% WHITE BLANC -5

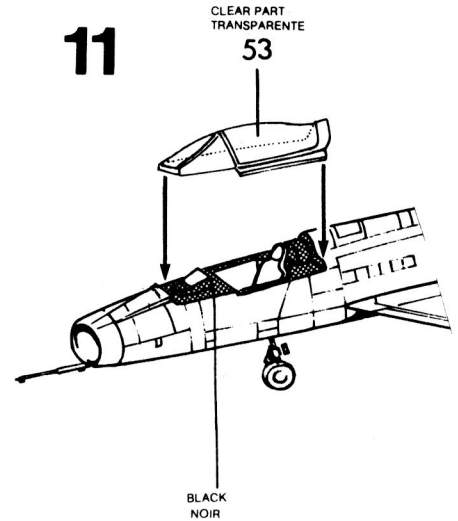

**A** N A F-100 D  
U S A F - 481 T F S.

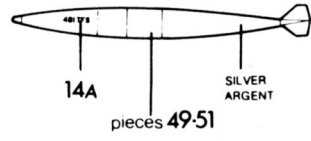
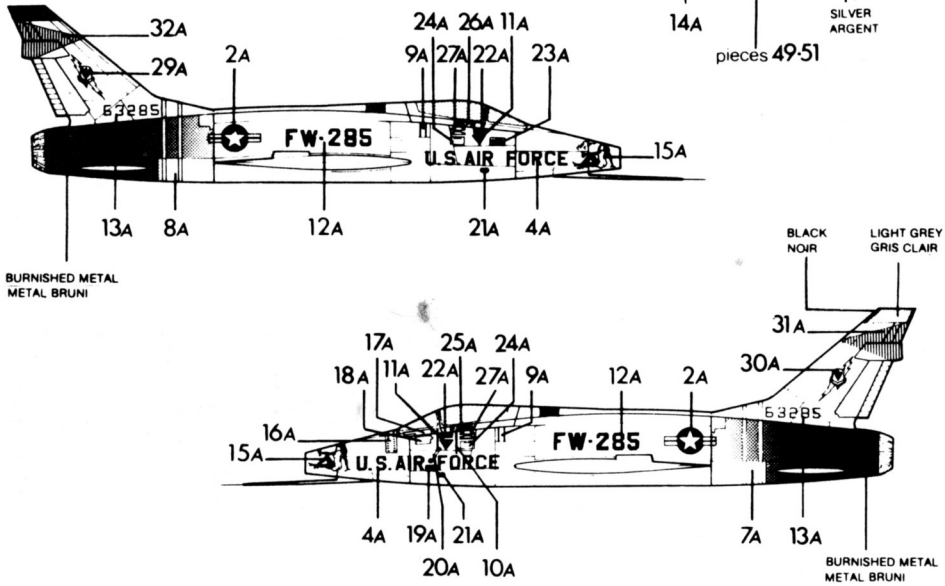

**B** N A F-100 D  
AIR NATIONAL GUARD - 184 T F S.

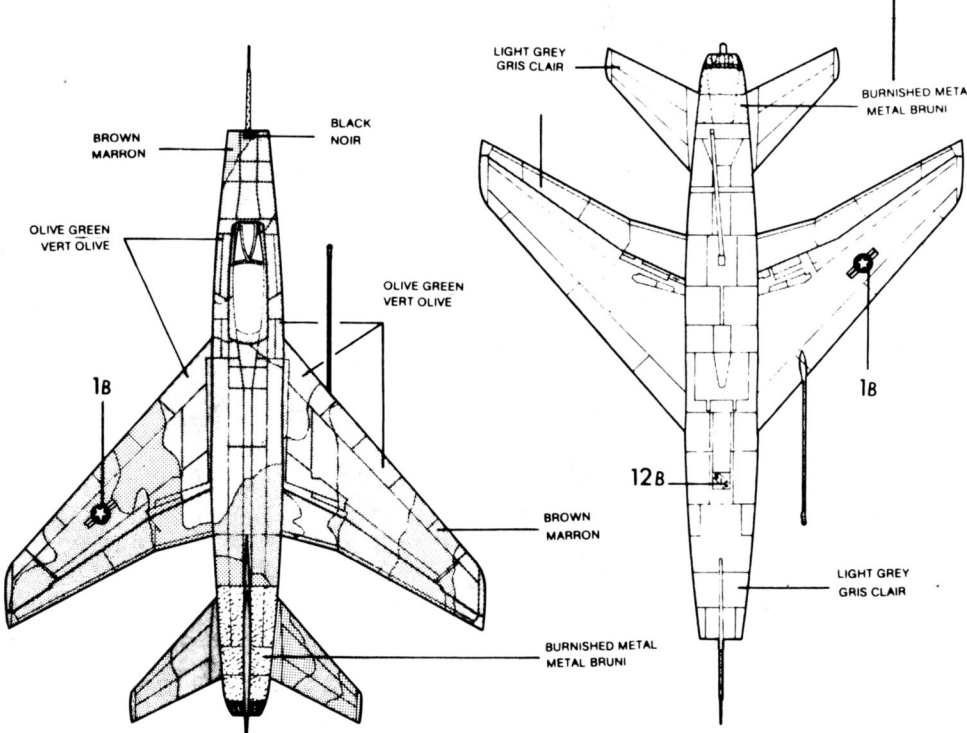
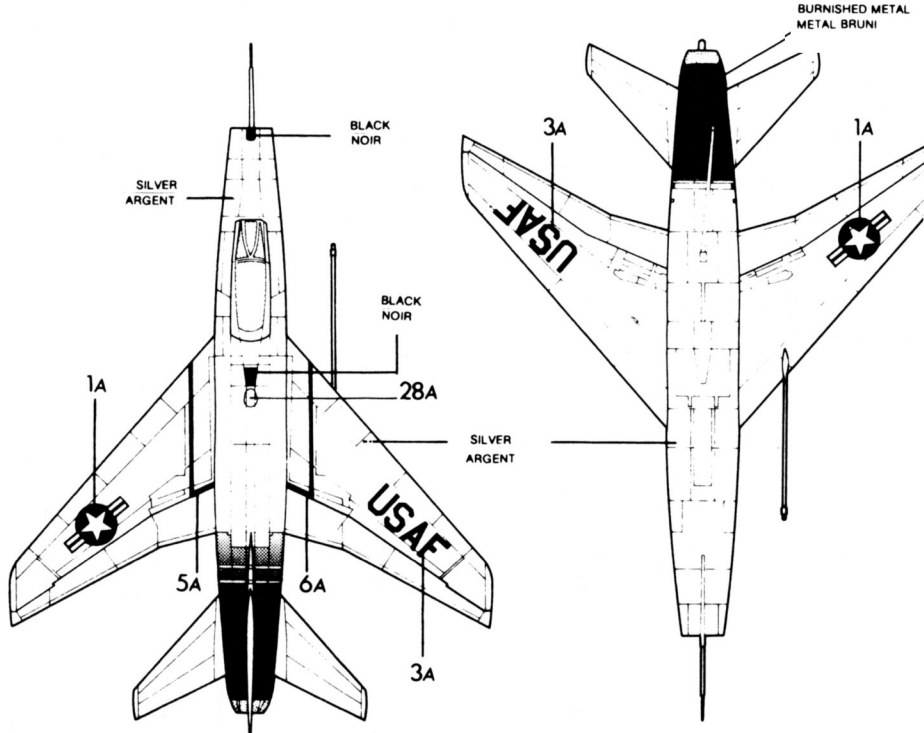
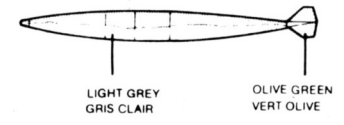
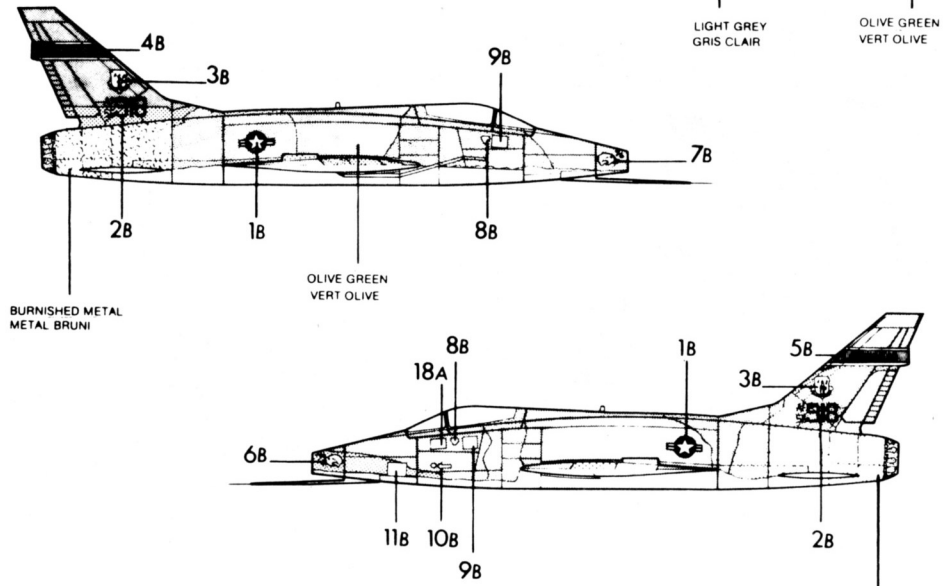

**C**

N. A. F-100 D  
 ARMÉE DE L'AIR - E.C. 4/11 - JURA.

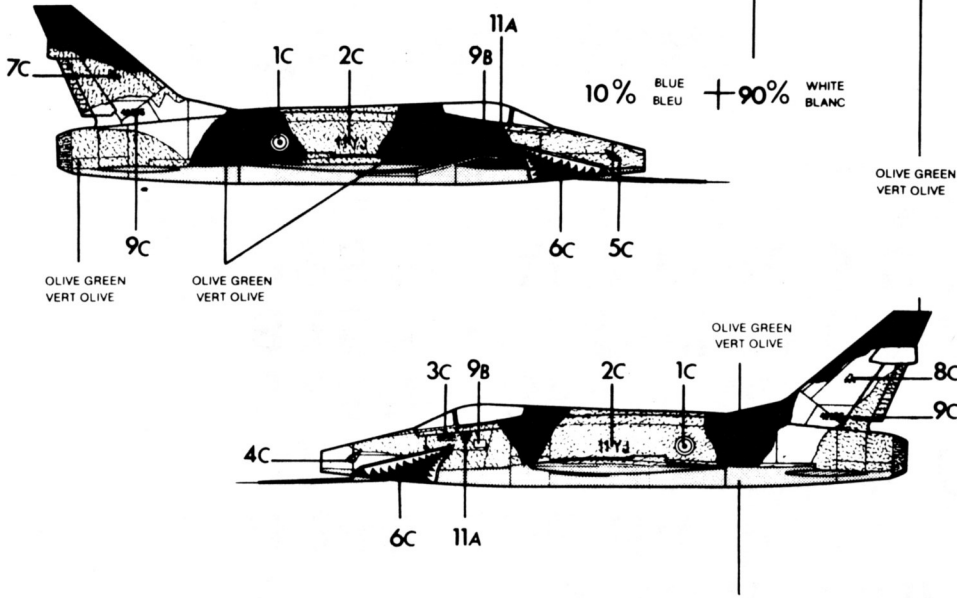

10% BLUE BLEU + 90% WHITE BLANC

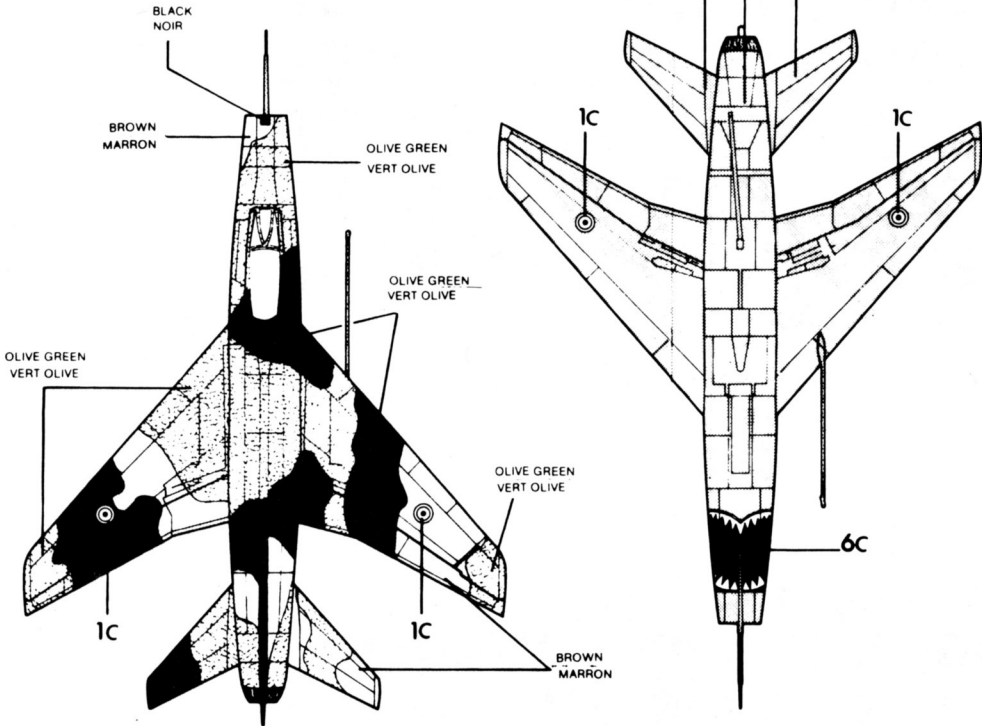
**D**

N. A. F-100 D  
 KONGELIGE DANSKE FLYVEVABNET, ESCADRILLE 730

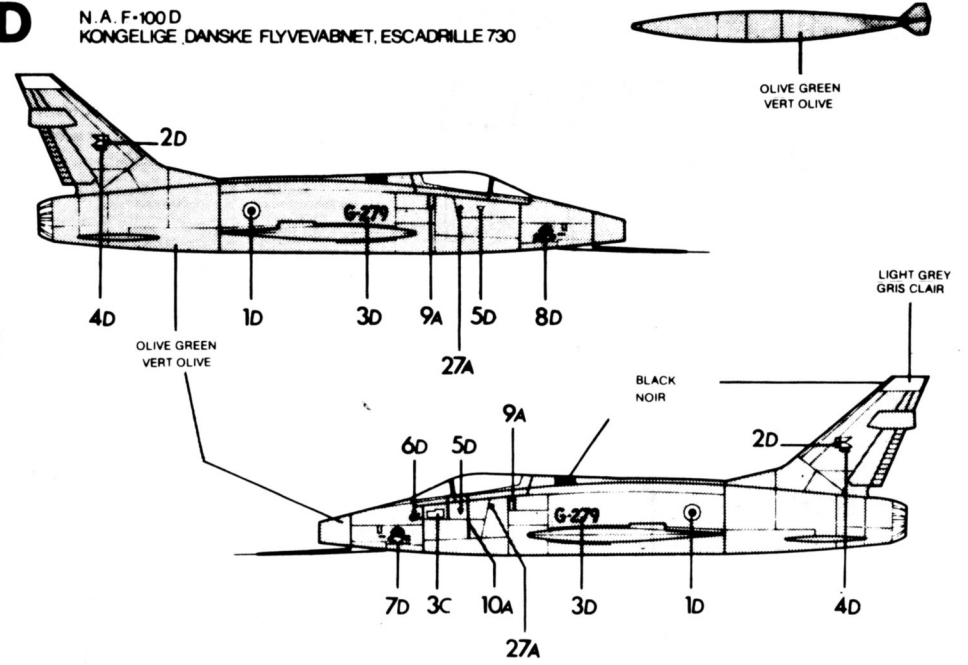

10% BLUE BLEU + 90% WHITE BLANC

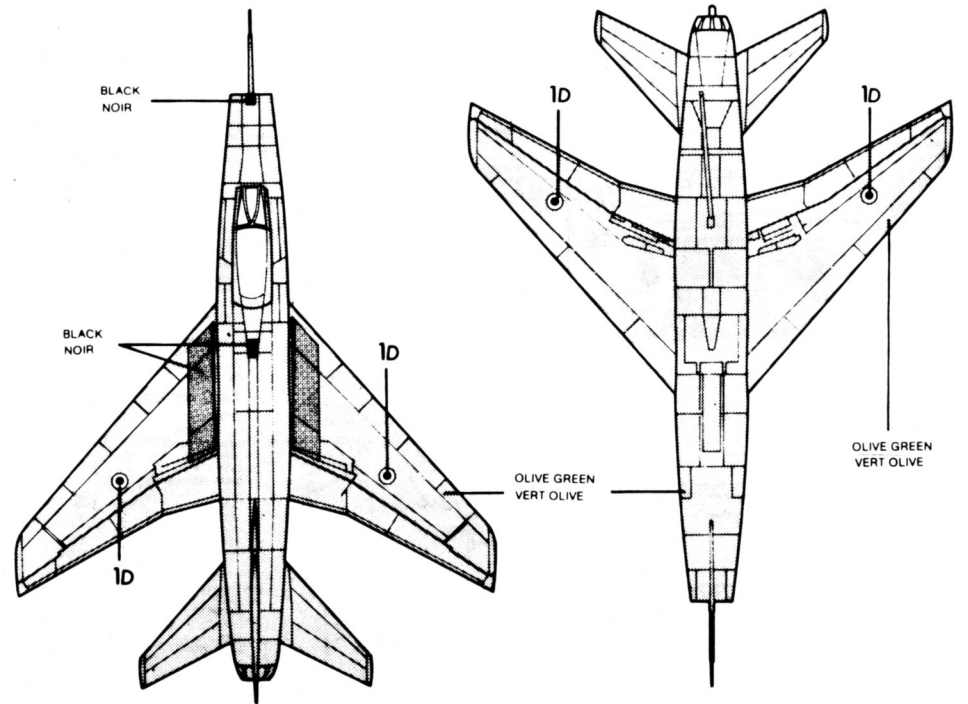

---

**Be sure to look for these other  
authentically detailed ERTL scale model kits  
at your favorite hobby store.**

---

- 8218 - UH-ID RESCUE CHOPPER**
  - 8219 - UH-ID U.S. CITY POLICE**
  - 8221 - CESSNA SEAPLANE**
  - 8246 - DOUGLAS DC-3 DAKOTA-TWA**
  - 8251 - DOUGLAS R4D-5**
  - 8247 - FOKKER D VII**
  - 8248 - SE 5A**
  - 8249 - NIEUPORT 17C**
  - 8250 - SPAD XIII**
  - 8252 - SOPWITH CAMEL**
  - 8253 - ALBATROS D111**
- 

Made in Italy by ESCI for The Ertl Company  
Dyersville, Iowa 52040, Subsidiary of Kidde, Inc.  
Printed in U.S.A.

Form No. 099-0519

**ERTL**  
Subsidiary of Kidde, Inc.  
**KIDDE**