

1/48

**Special HOBBY** *Azur* limited run plastic kits  
High quality injected plastic kits - short run/ Vstřikované modely - limitovaná série

**French Colors 1914 - 1945**

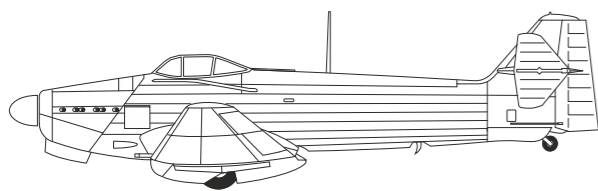

SH48058 Loire-Nieuport LN 40/401

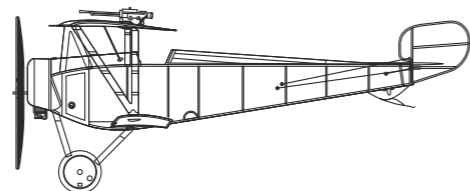

SH48082 Nieuport 10 "Single Seater" 1/48

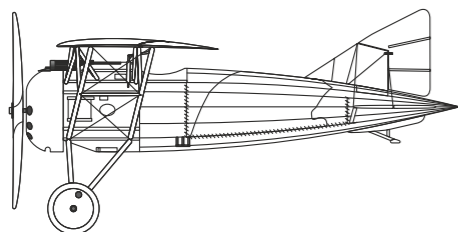

SH48099 Morane Saulnier AI

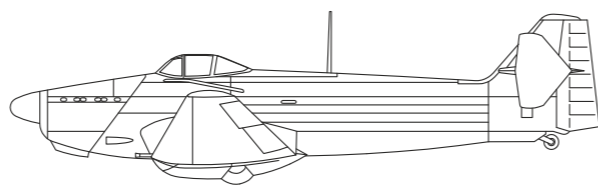

A028 SH48099 Loire-Nieuport LN 411 1/48

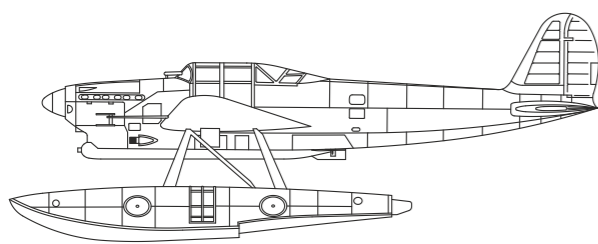

A022 Latécoere 298

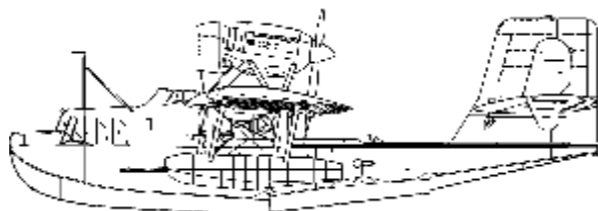

A038 SH48099 Loire 130M 1/48

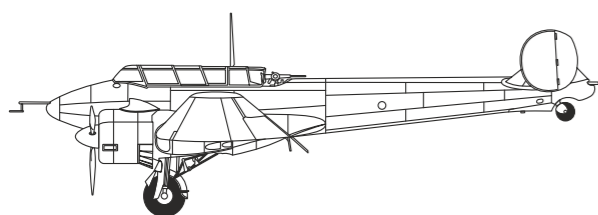

A057 Potez 630

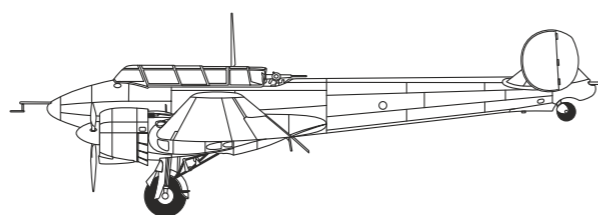

1/48 SH48058 Potez 631 1/48

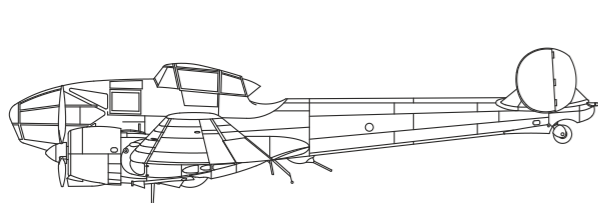

A059 Potez 63-11

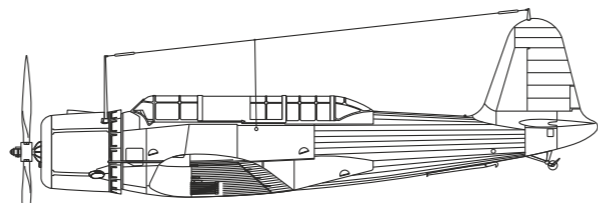

1/48 SH48084 V-156F Vindicator "French Navy" 1/48

**Special HOBBY**  
1/48

SH 48125

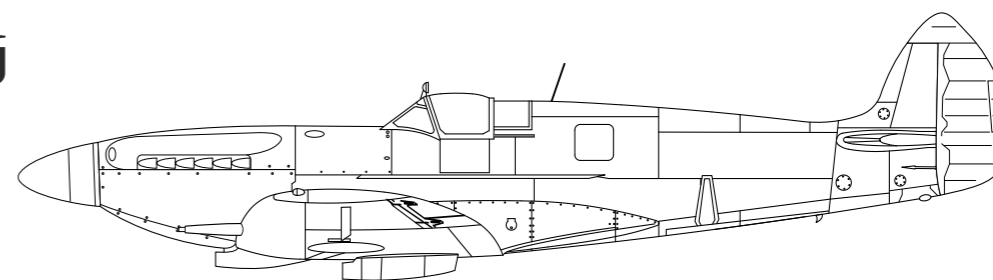

### Seafire F Mk.XV „Aéronavale Service“

**GB** To boost the performances of new Seafire versions, Supermarine Company similarly to Spitfire development used R&R Griffon engine. Slightly heavier and bigger Griffon engine offered considerably higher power output than R&R Merlin that powered Seafire Mk.I-III. The development of Griffon powered Seafire version was started in 1943.

The new version was somewhat crossover of several existing Spitfire and Seafire versions. The fuselage was taken over from Seafire Mk.III, tail planes were from Spitfire Mk.VIII and altogether it was powered by Griffon Mk.IV driving four-bladed Rotol propeller. Later version of Spitfire, particularly Mk.XII was powered by same engine. But the new Seafire designated Mk.XV was equipped with symmetrical coolers under each wing's halves. The armament consisted of two 20 mm cannons and four 7.7 mm machine guns. The mass production started at Cunliffe-Owen (182 produced machines) and Westland (246 machines); Supermarine manufactured only the prototypes. The first 51 produced aircraft were still equipped with "A" arrestor hook mounted below the fuselage. This assembly unfortunately strained the already strengthened fuselage and therefore the subsequent machines were equipped with "Stinger" arrestor hooks located at the end of the fuselage. This solution led to the change of the vertical fin's rudder. Initially Seafire suffered by griffon engine troubles; the compressor's clutch often slipped during take-offs. Seafire Mk.XV came to combat squadrons in 1945 with possible assignment to Far East. However, these machines came too late to take part in the fights there. Eventually, eight combat FAA squadrons were equipped with Seafire Mk.XVs. Seafire were also exported to Canada, France and Burma. Royal Canadian Navy used these Seafires aboard HMCS Warrior, the sole Canadian aircraft carrier, and on ground bases. Similar deployment occurred in France with Aéronavale. French Seafires operated from aboard Arromanches aircraft carrier as so from the ground bases. Burma stripped all naval equipment from their Seafires and deployed them against China supported Communist terrorists in 1950. Since 1947 when the change in designation of British aircraft was introduced, this Seafire version was re-designated to Mk. 15.

Technical Data: Wing Span: 11.23m, Length: 9.71 m, Max. Speed: 616 kmh, Range: 692 km/without external fuel tanks, Service Ceiling: 12,000 m.

**CZ** Podobně jako u vývoje verzí Spitfiru, použila firma Supermarine při snaze zvýšit výkony nových verzí Seafiru, motor R&R Griffon. Griffon nabízel při mírně vyšší váze a větších rozměrech podstatně větší výkon než R&R Merlin, dosud používaný ve Seafirech Mk.I-III. Vývoj verze Seafiru s Griffonem byl zahájen v roce 1943.

Nově vzniklá verze vznikla jakoby křížením několika verzí Spitfiru a Seafiru. Trup převzatý ze Seafiru Mk.III doplnily ocasní plochy Spitfiru Mk.VIII a motor Griffon Mk.IV se čtyřlístou vrtulí Rotol. Shodný motor poháněl pozdější serie Spitfiru Mk.XII. Ale nový Seafire, označený Mk.XV dostal pod křídlo symetrické chladiče. Výzbroj tvořily dva kanony ráže 20 mm a čtyři kulometry 7,7 mm. Sériová výroba se rozeběhla u firem Cunliffe-Owen (182 ks) a Westland(246 ks), Supermarine vyrobil pouze prototypy. Prvních 51 vyrobených kusů mělo ještě namontován „A“ hák pod trupem. tato montáž namáhala i zesílený trup nových Seafirů. dalším vyrobeným Seafirům byl proto montován hák „žihadlo“ na konci trupu. To bylo spojeno i se změnou kormidla svislé ocasní plochy.

Seafiry Mk.XV měly ze začátku problémy s motory Griffon, při startu často prokluzovala spojka kompresoru. Do řadové služby se dostaly v květnu 1945 a měly být nasazeny na Dálném východě. Již však nestihly zasáhnout do bojů. FAA nakonec vyzbrojilo Seafiry Mk.XV osm bojových squadron. Seafiry byly i exportovány do Kanady, Francie a Barmy. Royal Canadian Navy Seafiry Mk.XV používalo na jediné kanadské letadlové lodi HMCS Warrior i na pozemních základnách. Stejně použití měla pro Seafiry i francouzská Aéronavale.

Francouzské Seafiry operovaly jak z paluby letadlové lodi Arromanches, tak z pozemních základen. Barma své Seafiry zbavila námořního vybavení a nasadila je po roce 1950 proti komunistickým teroristům podporovaných Čínou. Od roku 1947 se používalo v souladu se změnou označování britských typů označení Seafire Mk. 15.

Technická data:  
rozpětí: 11,23m, délka: 9,71 m, max. rychlost: 616 km/h, dolet 692 km/bez příd. nádrží, dostup 12 000 m,



Bližší informace na internetových stránkách [www.cmkkits.com](http://www.cmkkits.com)  
Further information at internet pages [www.cmkkits.com](http://www.cmkkits.com)

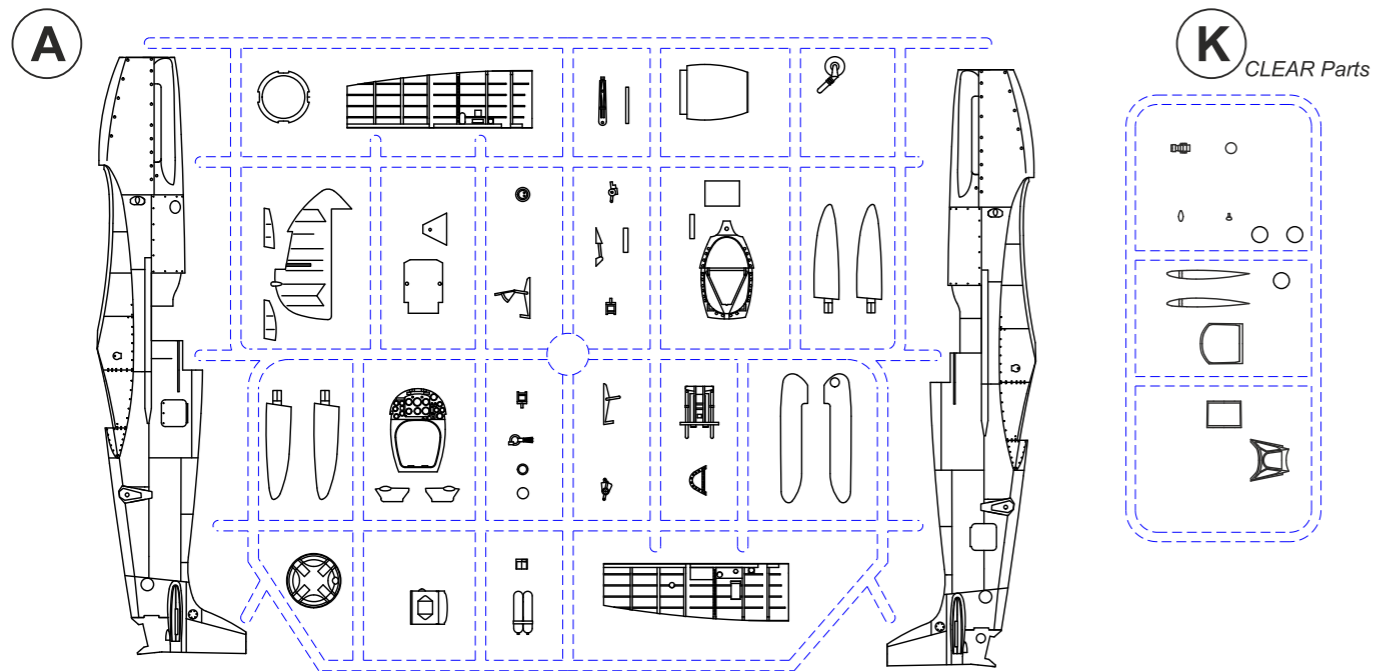

**K** CLEAR Parts

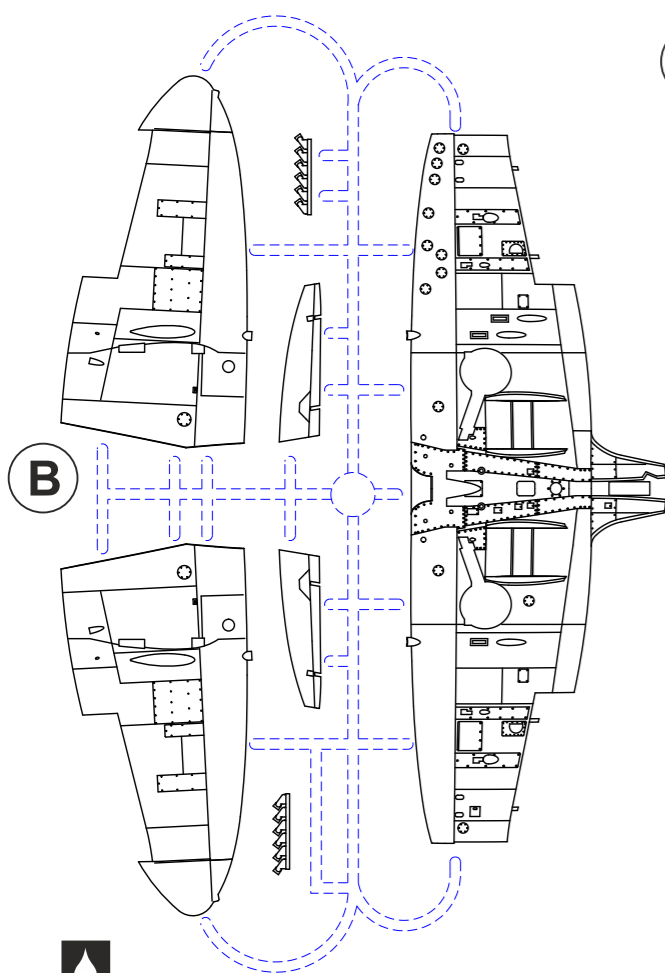
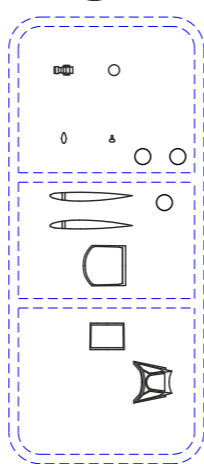

**C**

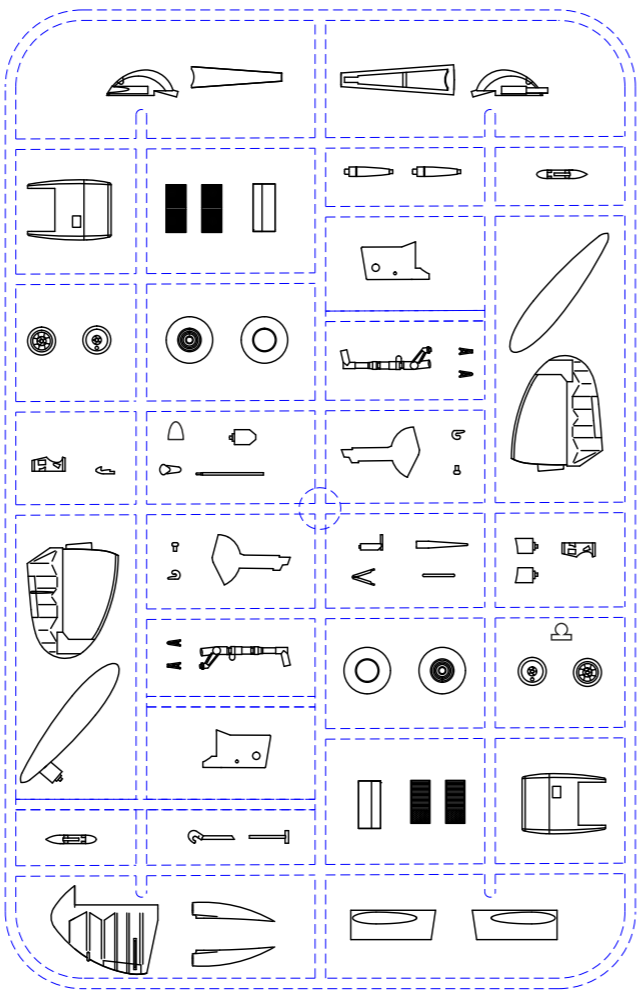
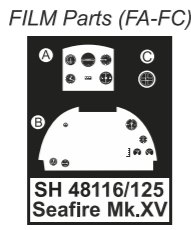
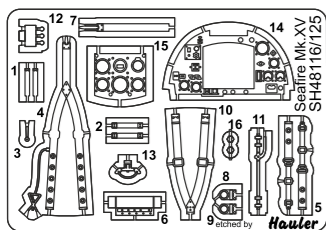

PHOTO-ETCHED Parts (PP1-PP22)



**SYMBOLS**

MOŽNOST VOLBY OPTIONAL NACH BELIEBEN OPTION	POUŽIT KYANOAKRYLÁTOVÉ LEPIDLO INSTANT CYANOACRYLATE GLUE ZYANOAKRYLATKLEBER ADHÉSIF CYANOACRYLAT	OHNOUT BEND BIEGEN COURBER
ZHOTOVIT NOVÉ SCRATCH BUILD FERTIGSTELLEN ACHEVER	REZAT/VRTAT CUT OFF/DRILL ENTFERNEN DETACHER	GSI  A  B  C NATRÍT COLOUR FARBEN PEINDRE colours code

Seafire F Mk.15, PR347/12.F.15, Aéronavale , 12. Flotille, základna Hyères, 1949. Červené kormidlo je buď základ pro francouzskou trikoloru nebo důsledek opravy plátěného potahu (červený vypínací lak). Letoun je s takto natřeným kormidlem fotograficky doložen v letu.

Seafire F Mk.15, PR347/12.F.15, Aéronavale , 12. Flotille, Hyères air base, 1949. The rudder in red color is possibly the base for application of French rudder flash or the fabric cover repair (red stretching lacquer). There are in-flight photos of this aircraft that proves this red rudder.

**CAM. C**

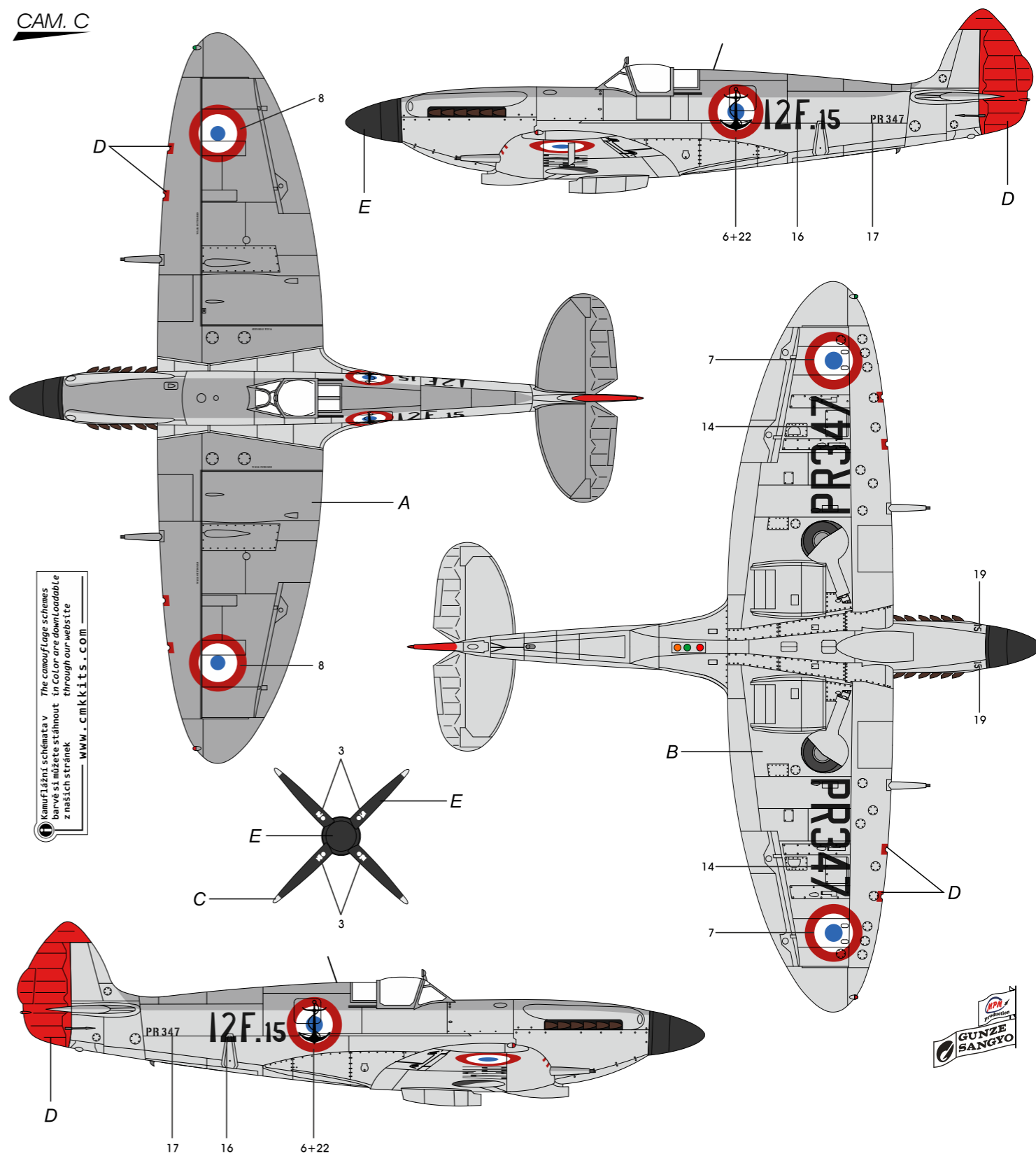

<b>A</b> Extra tmavá mořská šedá Extra Dark Sea Grey H333/C333	<b>B</b> Nebeská modrá Sky C368	<b>C</b> Žlutá Yellow H329/ C329	<b>D</b> Matná Červená Flat Red H43/ C100	<b>E</b> Matná Černá Flat Black H12/ C33
--	---------------------------------------	--	---	--





+ other colours on pages 9-12 (camouflage)/  
+ další odstíny barev na stranách 9-12

Barvy GUNZE/ GUNZE Colour No.	
A	Bílá/ WHITE
B	Černá lesklá/ GLOSS BLACK
C	Černá/ BLACK
D	Ocelová/ STEEL
E	Plátno/ TAN
F	Opálený kov/ BURNT IRON
G	Barva pneu/ TIRE BLACK
H	Šedozelená/ GREY GREEN
L	Hliníková/ ALUMINIUM
H1/C1	
H2/C2	
H12/C33	
H18/C28	
H27/C44	
H76/C61	
H77/C137	
C364	
MC218	

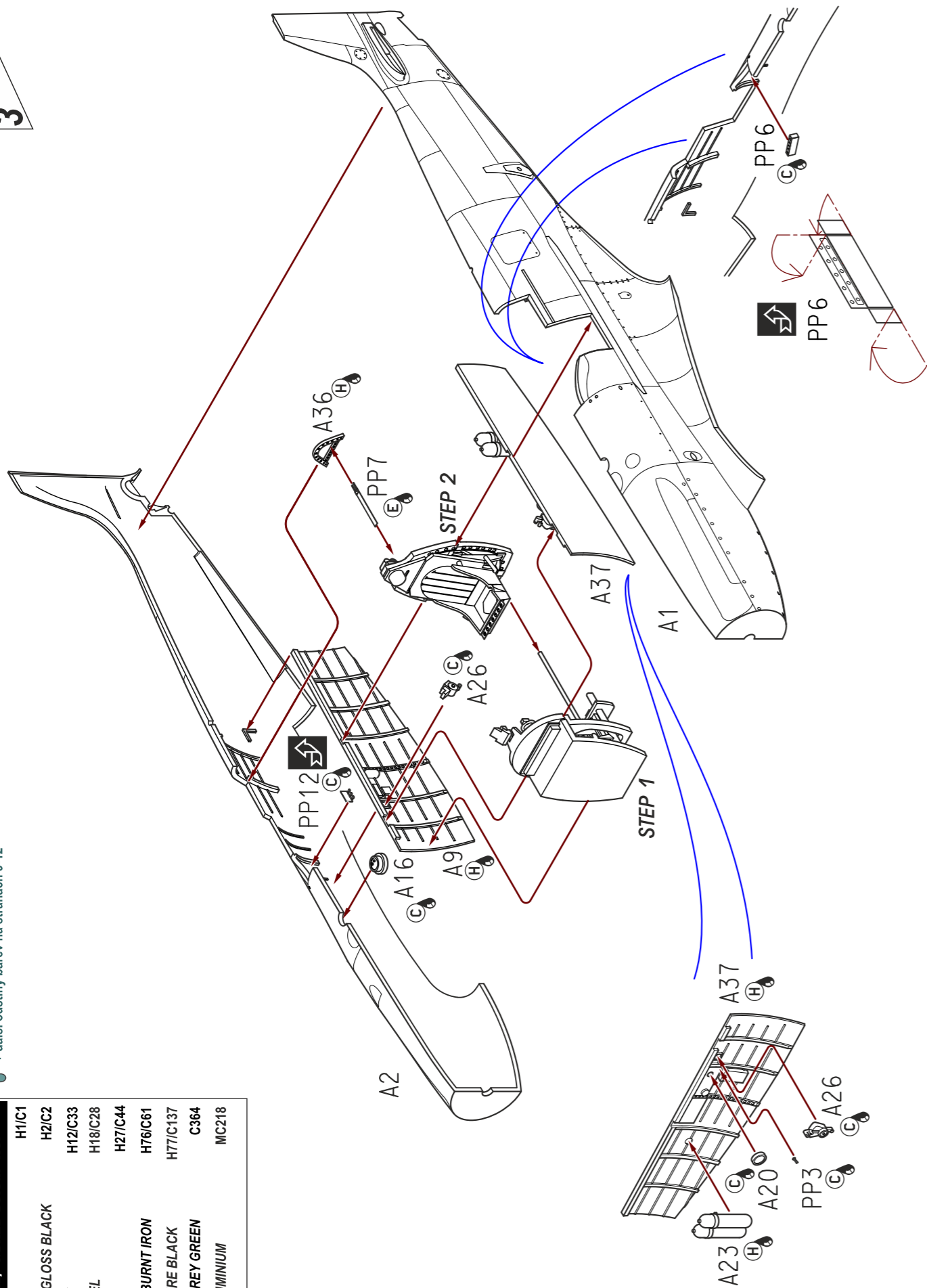

Seafire F Mk.15, SR520/54.S.26, Aéronavale, Escadrille de Servitude No.54, základna Hyères, 1948-1950. Stroj dříve používaný u 1. Flotille nesl stále britský seriál. Číslo 26 se opakovalo na obou stranách přídě (sloužilo k lepší identifikaci konkrétního stroje). Vrtulový kužel byl žlutý nebo nesl o něco tmavší odstín barvy Sky než zbytek trupu. Levá kulatá krytka na krytu motoru byla v barvě Sky.

Seafire F Mk.15, SR520/54.S.26, Aéronavale, Escadrille de Servitude No.54, Hyères air base, 1948-1950. This machine, earlier in its career used by 1. Flotille, still bore the British serial number. Number 26 was repeated on both sides of the nose (it served for better identification of the particular machine). The propeller's spinner was either yellow or was painted by darker shade of Sky color than the rest of the fuselage. The left service access panel on the engine cover was in Sky color, too.

CAM. A

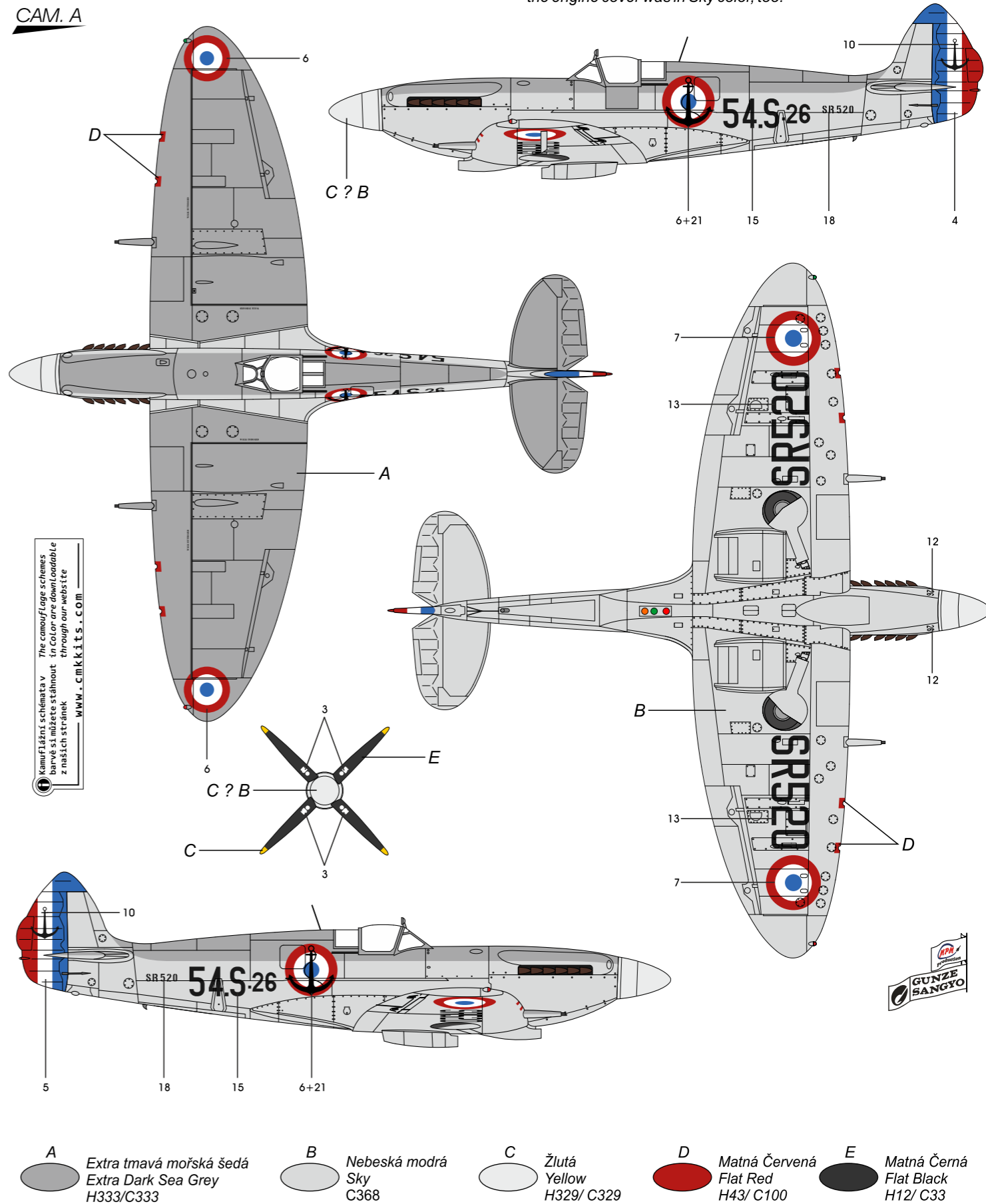

Kamuflažní schémata v barvě si můžete stáhnout z našich stránek [www.cmkkits.com](http://www.cmkkits.com)

- A** Extra tmavá mořská šedá / Extra Dark Sea Grey / H333/C333
- B** Nebeská modrá / Sky / C368
- C** Žlutá / Yellow / H329/ C329
- D** Matná Červená / Flat Red / H43/ C100
- E** Matná Černá / Flat Black / H12/ C33

10

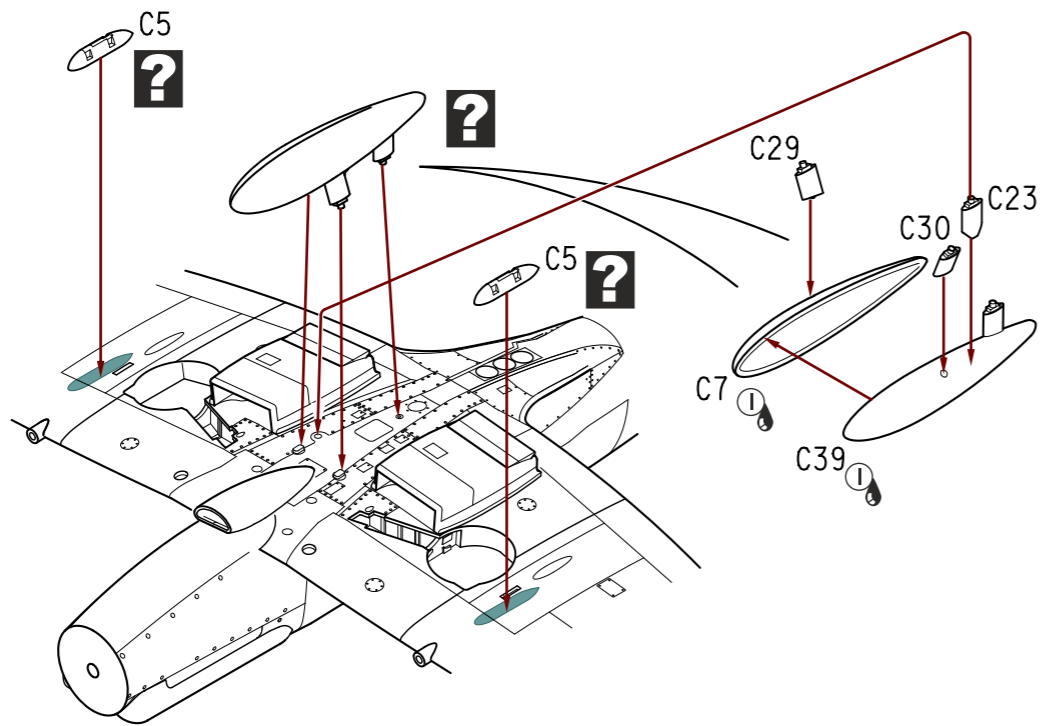

11

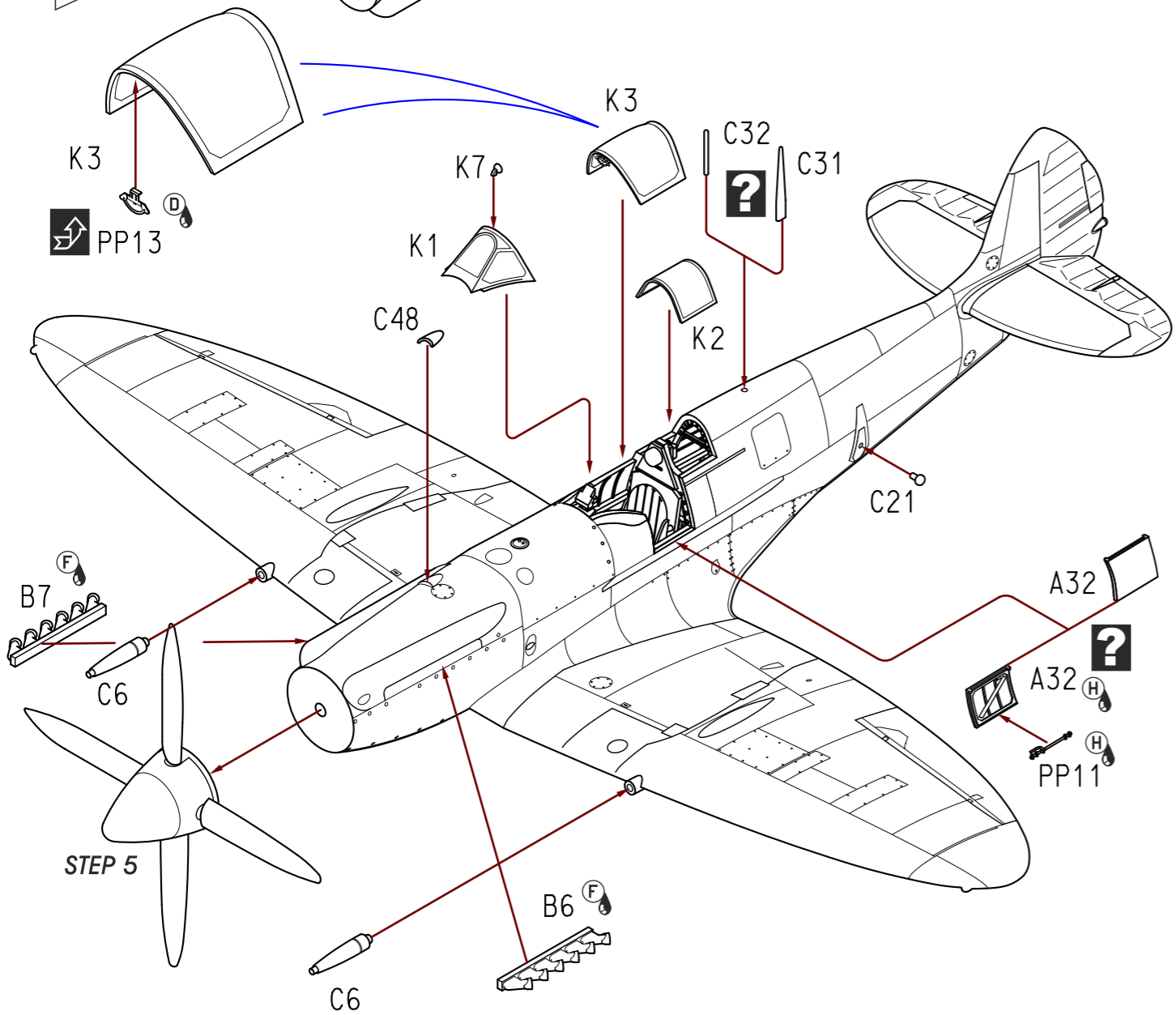

4

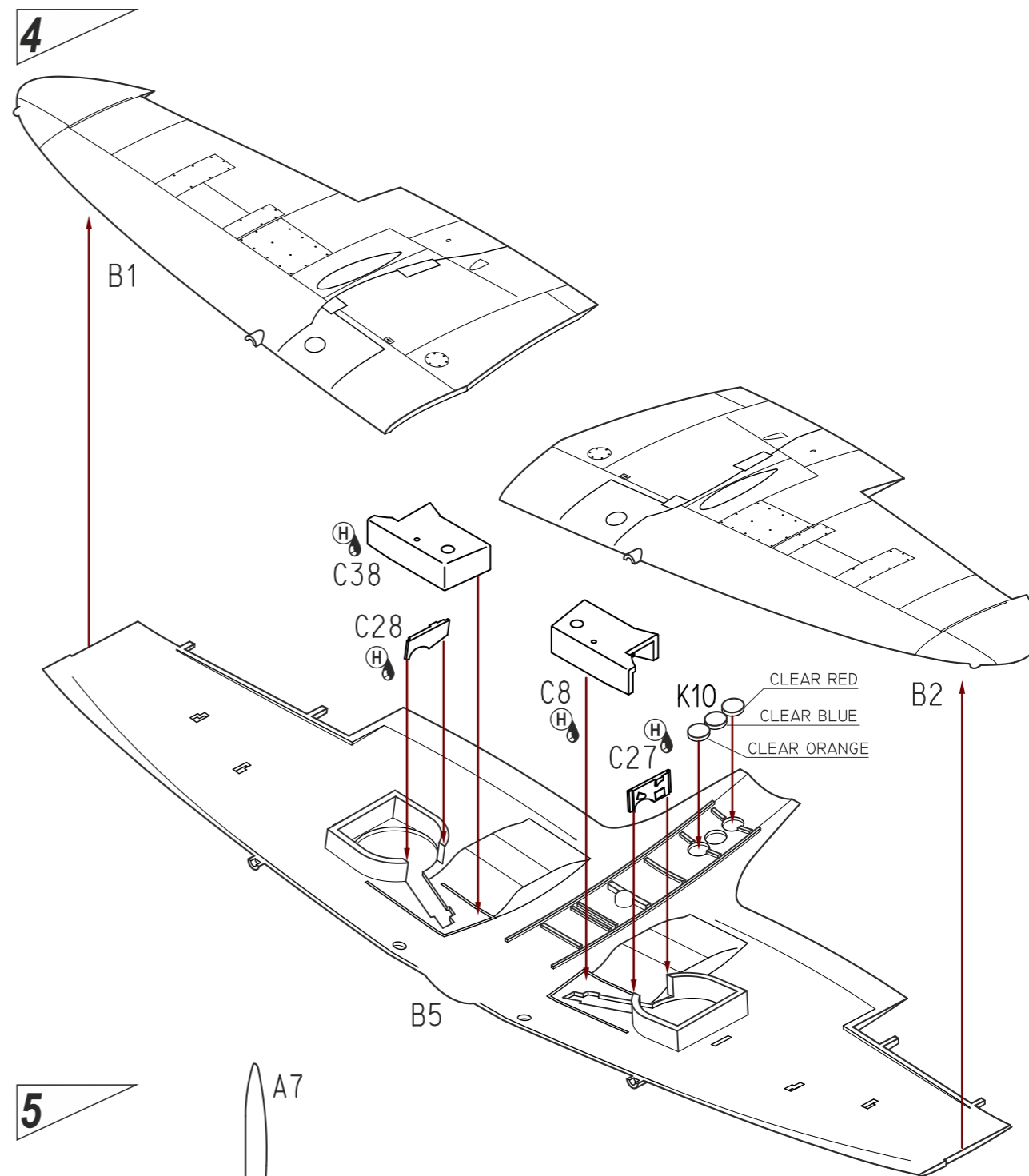

5

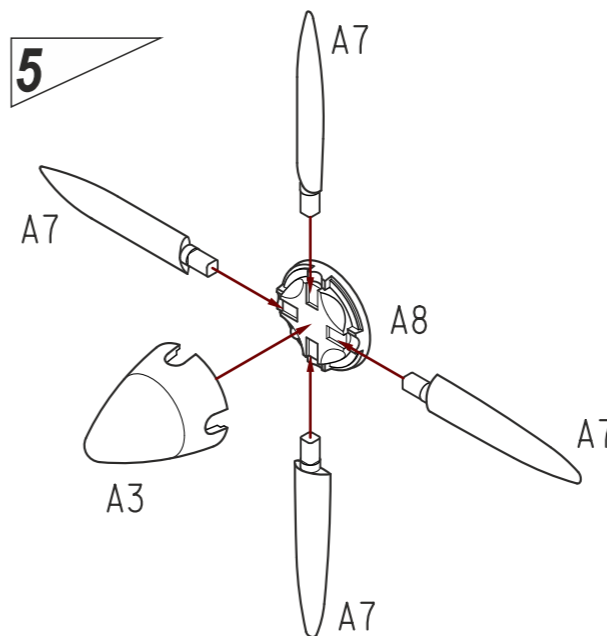

6

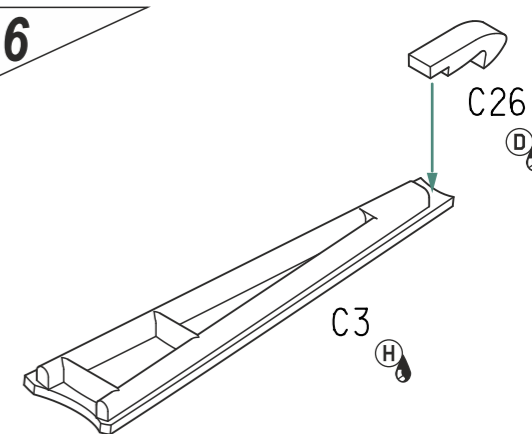

7

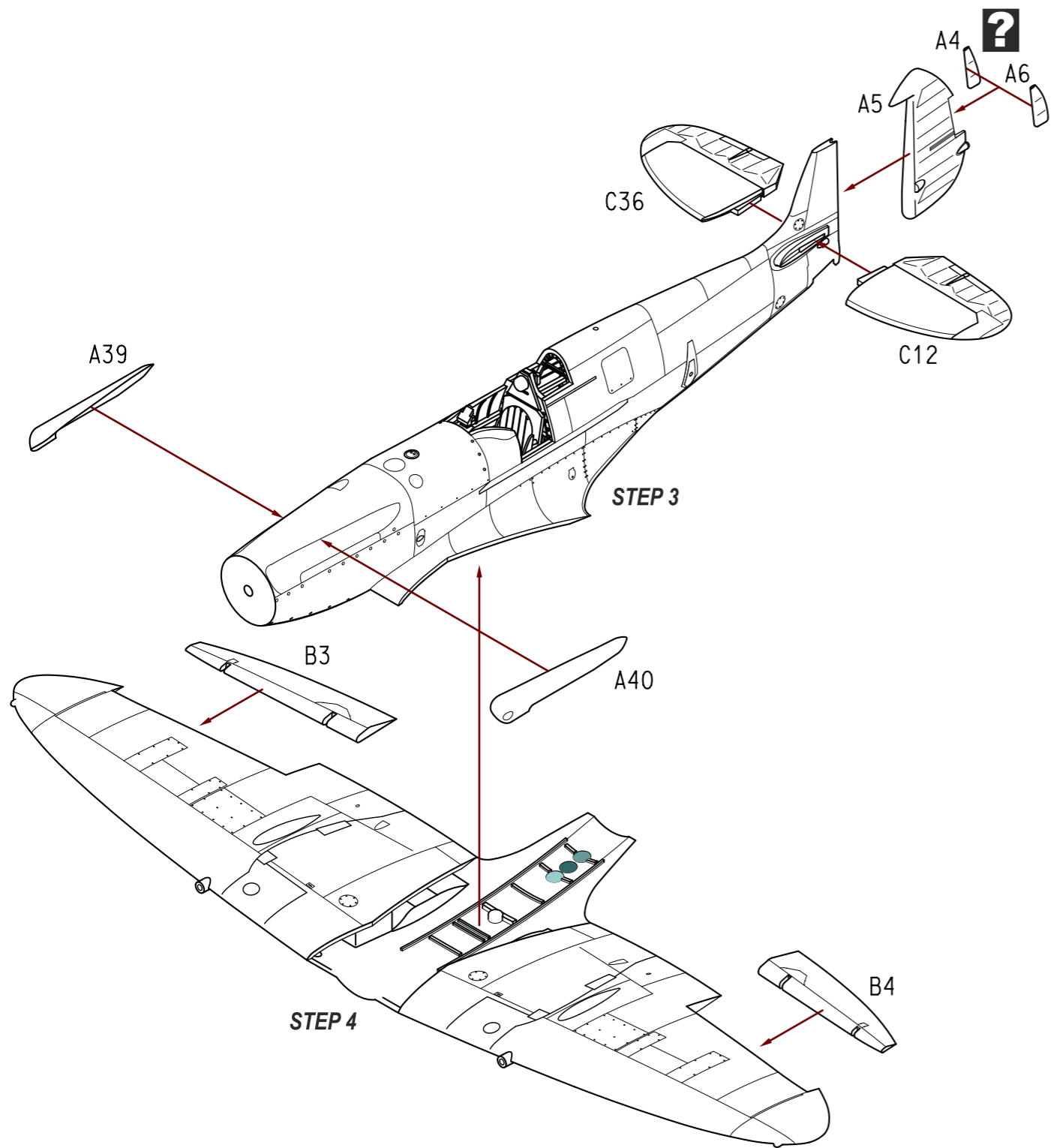

8

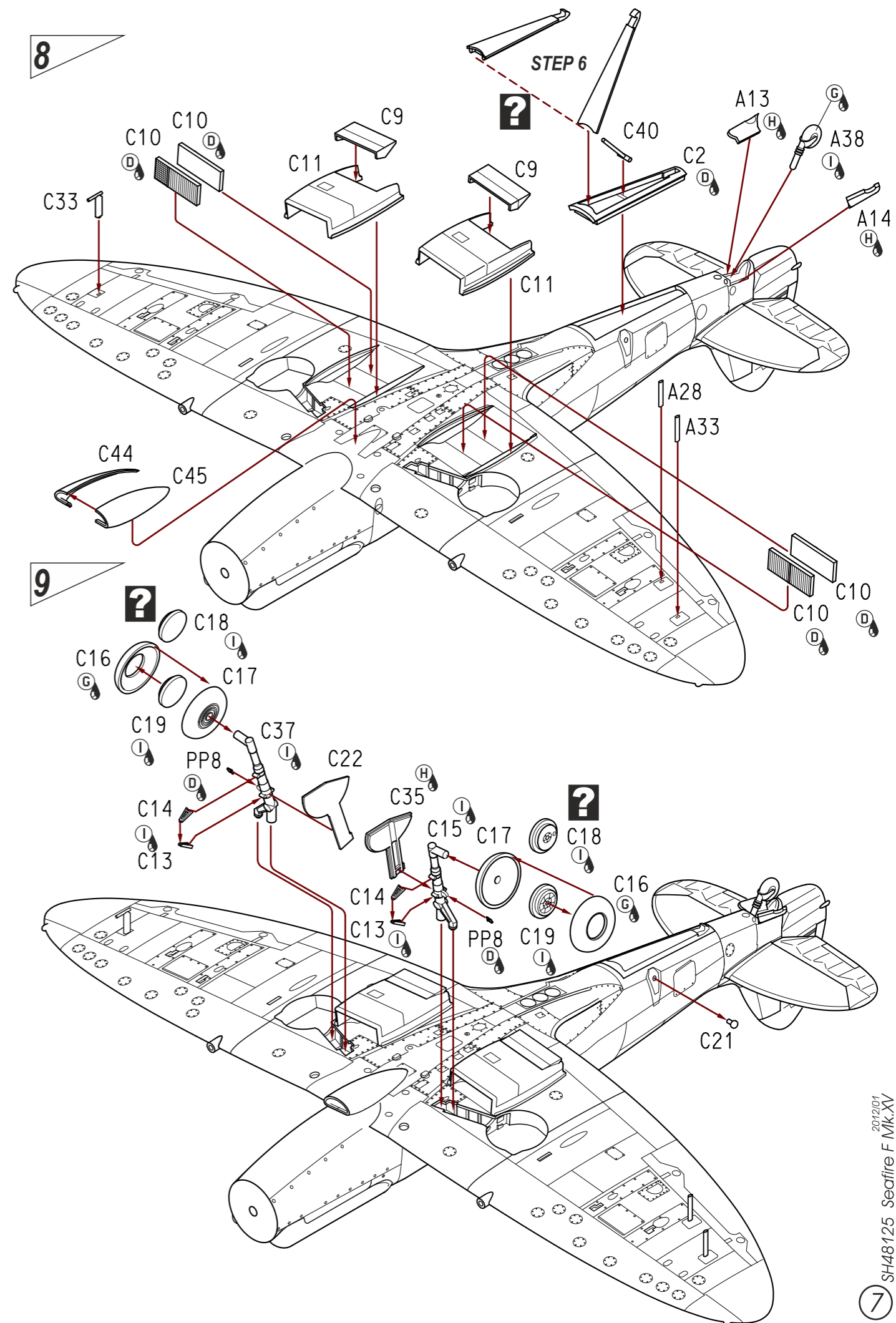

9