

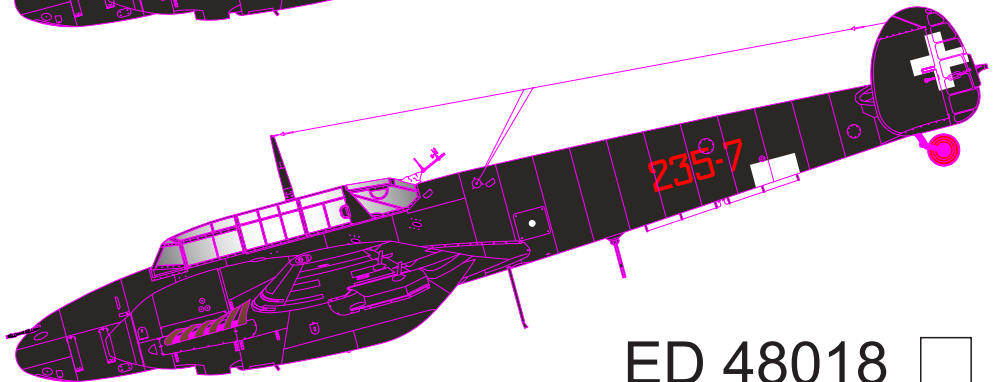

# First heavy night fighters in Italian service

Bf 110 C-3 in Regia Aeronautica

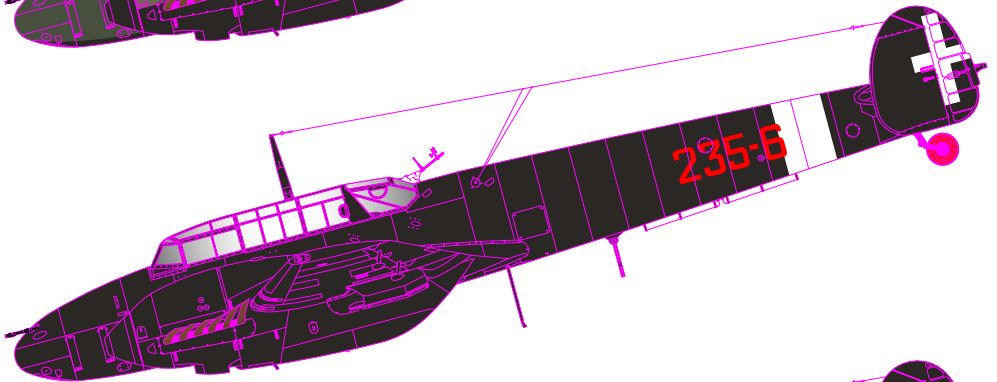
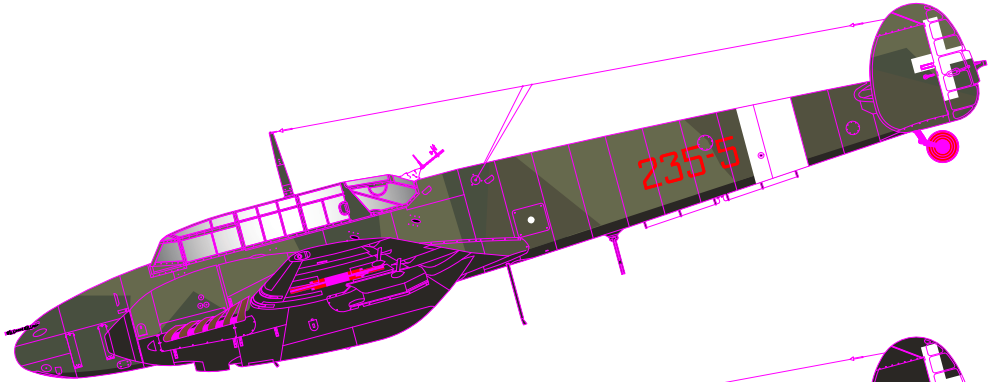

ED 48018

ED 72018

# Messerschmitt Bf 110C-3

## first Italian heavy night fighter

The problem to organize an efficient night aerial defence system in Italy was clearly evident at the beginning of 1942. All the attempts of developing a night fighter of national production had given scarce results, and there was not a suitable structure of support. Again it was necessary to address to the German ally, that had already accumulated a notable operational experience in this sector.

In January 1942, an aeronautical commission visited some installations of the Luftwaffe, such radar ground stations and night fighter units. From the report compiled after the visit, emerged the necessity to acquire twenty four twin engined Bf 110C-3s. In the meantime the night fighter operational structure was defined.

On 15th February 1942 the Commando Intercettori Leone was formed and two operational training units were assigned to it: the 1st Nucleo Addestramento Intercettori (1 N.A.I.) based at Treviso and the Scuola di Volo Senza Visibilita (S.V.S.V) at Linate. To these units, intended for the training of the personnel, the 41st Stormo was added.

On 18th February 1942, the 41st Stormo left the bombing role, to become a Stormo Caccia, with two Gruppi: the 59th (232nd and 233rd Squadriglias) and the 60th (234th and 235th Squadriglias).

Only in June 1942 the first Italian crews headed for Germany to begin the training for night operations and to obtain the qualification on the Bf 110C-3. When the training was completed, the crews came back to Italy with the first two Bf 110 C-3.

In July, after a visit in Italy a German commission led by gen.Kammhuber, a new agreement was signed, regarding the supply of the twin-engined aircraft for the night fighter duties. Unfortunately the aircraft offered were not the Bf 110C-3s, as stated in the previous agreement, but on the contrary, were the Dornier Do 217s in the versions J-1 and J-2. An order was signed for twelve Do 217Js and three Bf 110C-3s.

In September 1942 the first two Do 217J-1s were delivered and assigned to the 235th Sq., together with the third Bf 110C-3.

All planes were not new machines and had already an intense operational life, achieved during their duty with the training schools and the operational night fighter units, with consequent high wear of the engines.

On 21st October 1942 the 235th Sq. moved to Lonate Pozzolo airfield, and was combat ready with two Do 217 J-1s and two Bf 110 C-3s (third one was unserviceable).

On 25th October 1942 the first operational order for the employment of the night fighters of the 235th Squadriglia had been given. Two Do 217s were operated in the Biella-Venegono-Como area, when the two Bf 110s were employed in the north of the Turin. At summer 1943 235th Sq. still had in charge two Bf 110s (third one crashed in spring 1943) but theirs serviceability declined quickly to the minimum, so that they were written-off.

info based on Fabrizio Becchetti & Marco Gueli „Ali Straniere in Italia - Gli Altri Tedeschi” book.



© Exotic Decals

Exotic Decals are distributed by ToRo Model - Tomasz Mańkowski  
1/28 Sobieskiego Str. 05-510 Konstancin Jeziorna, Poland  
[www.toro-model.com.pl](http://www.toro-model.com.pl)

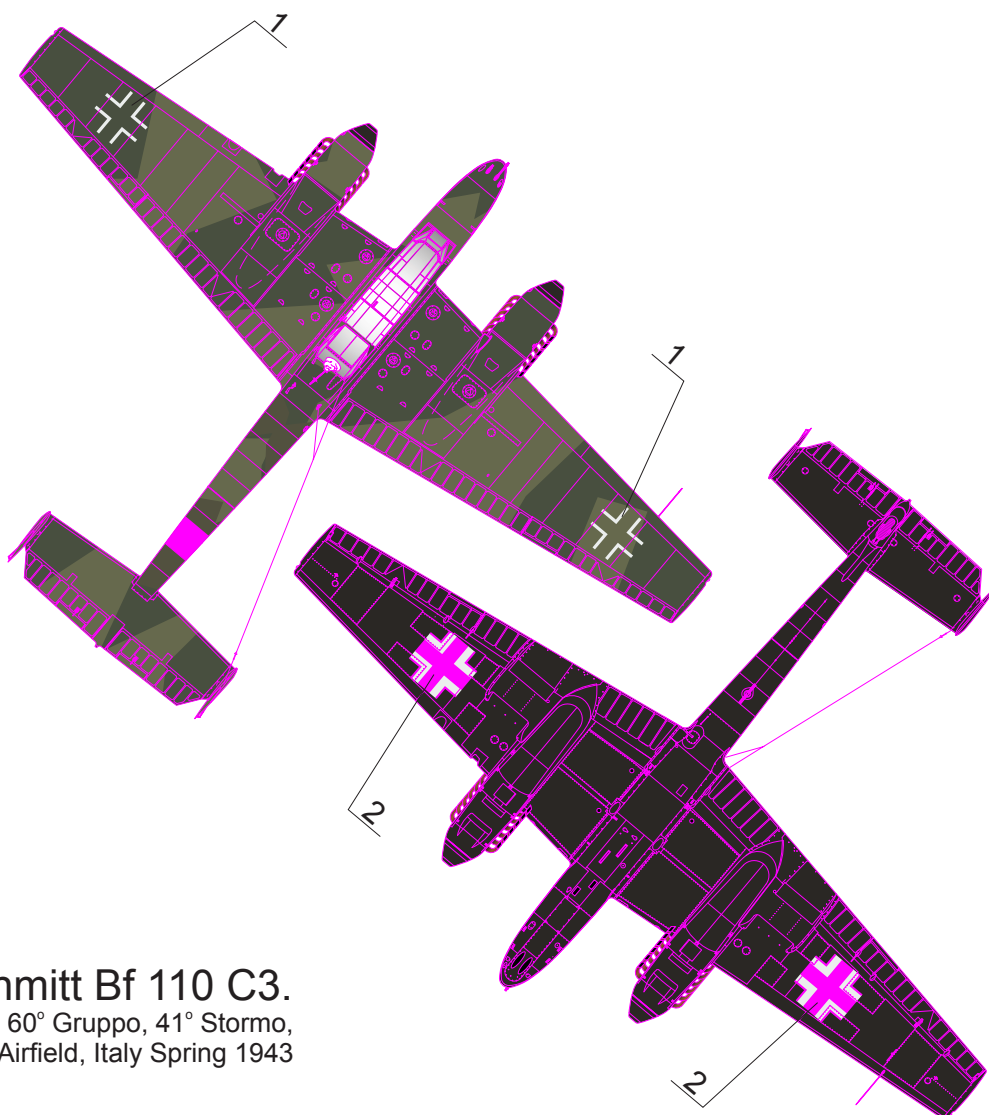
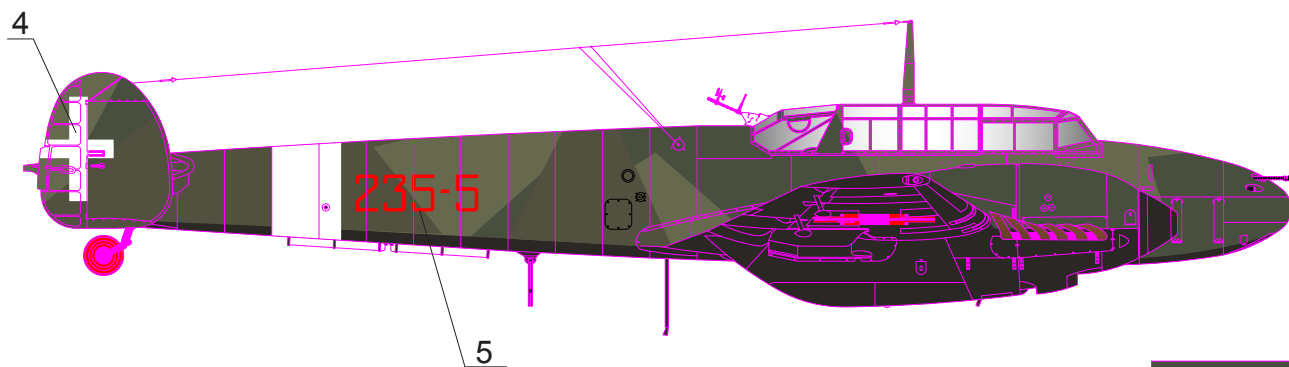
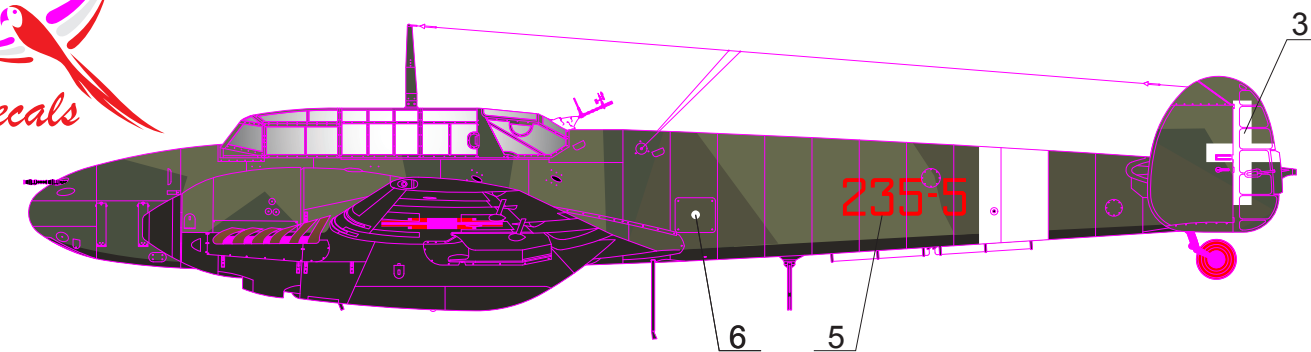

|                     |
|---------------------|
| RLM 70              |
| RLM 71              |
| RLM 22              |
| Verde Oliva Scuro 2 |
| Bianco              |

**Messerschmitt Bf 110 C3.**  
235ª Squadriglia 60° Gruppo, 41° Stormo,  
Lonate Pozzolo Airfield, Italy Spring 1943

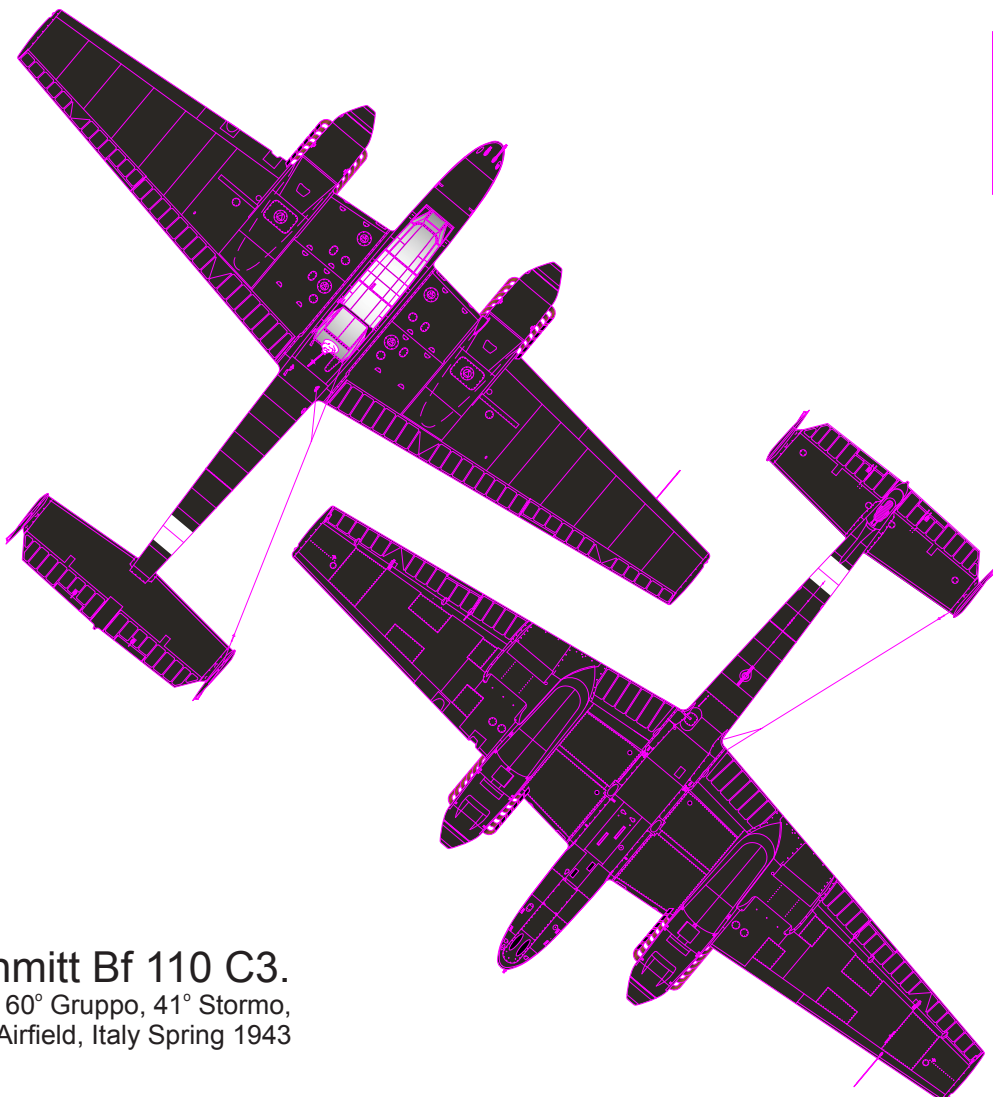
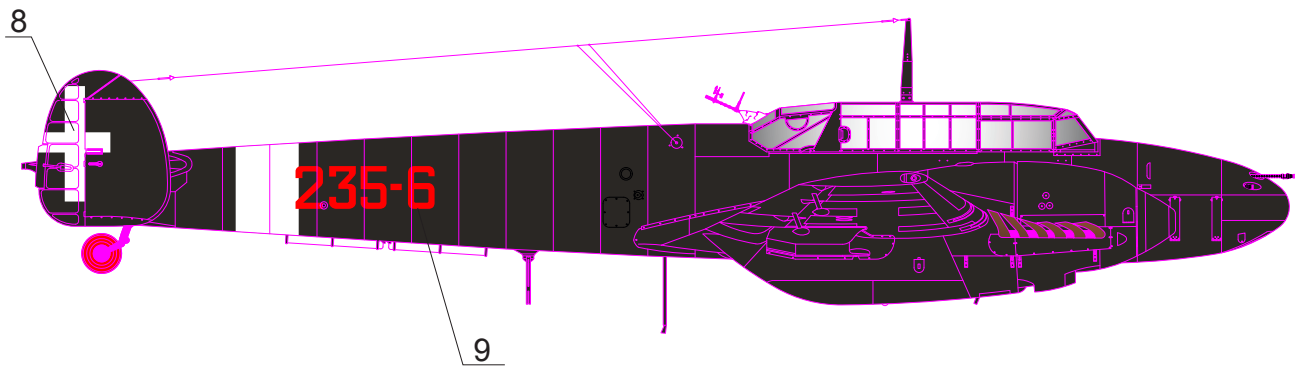
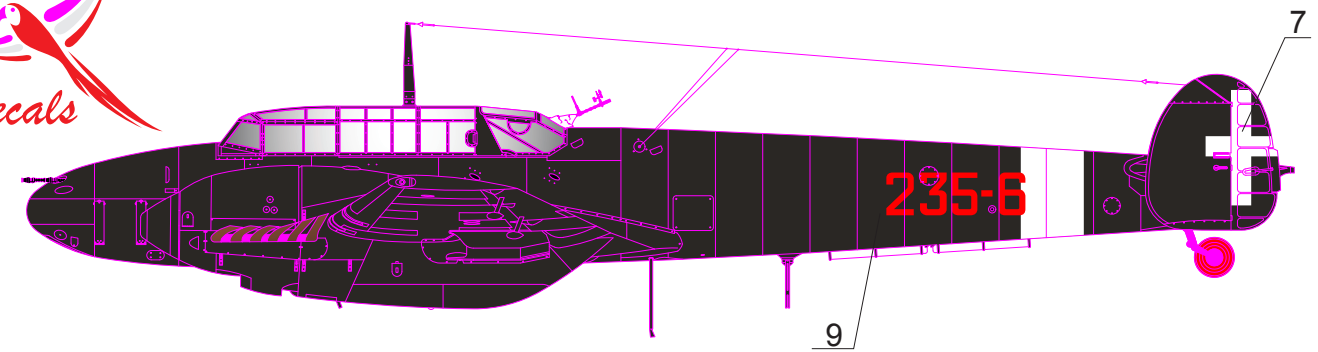

|        |
|--------|
| RLM 22 |
| Bianco |

Messerschmitt Bf 110 C3.  
235ª Squadriglia 60º Gruppo, 41º Stormo,  
Lonate Pozzolo Airfield, Italy Spring 1943

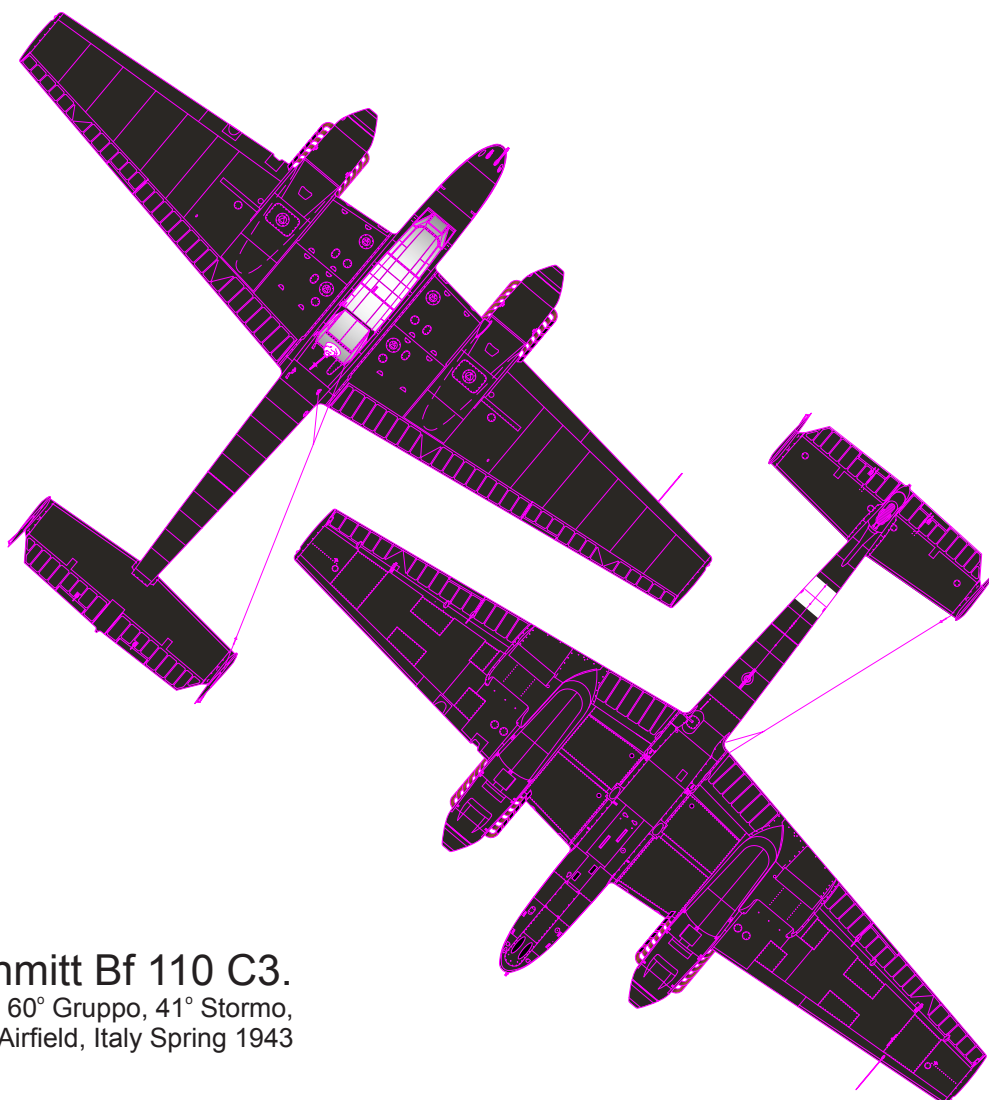
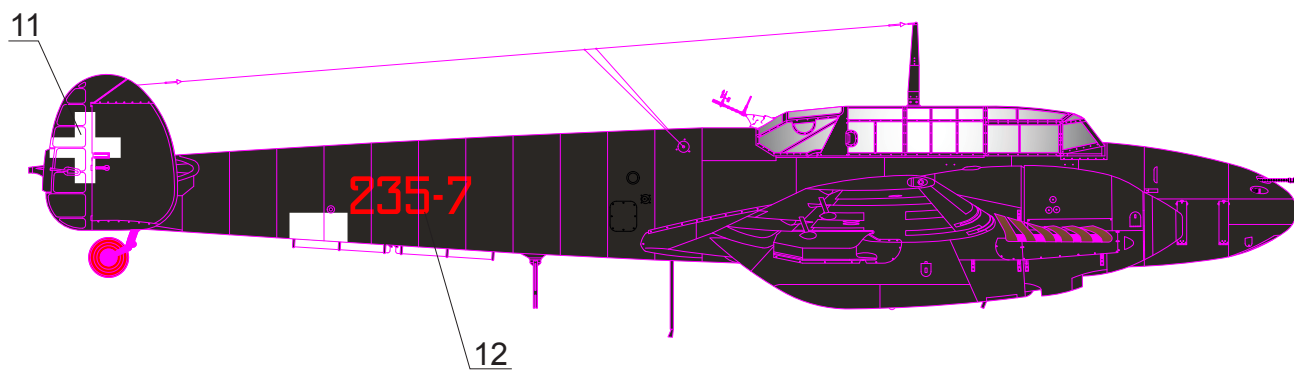
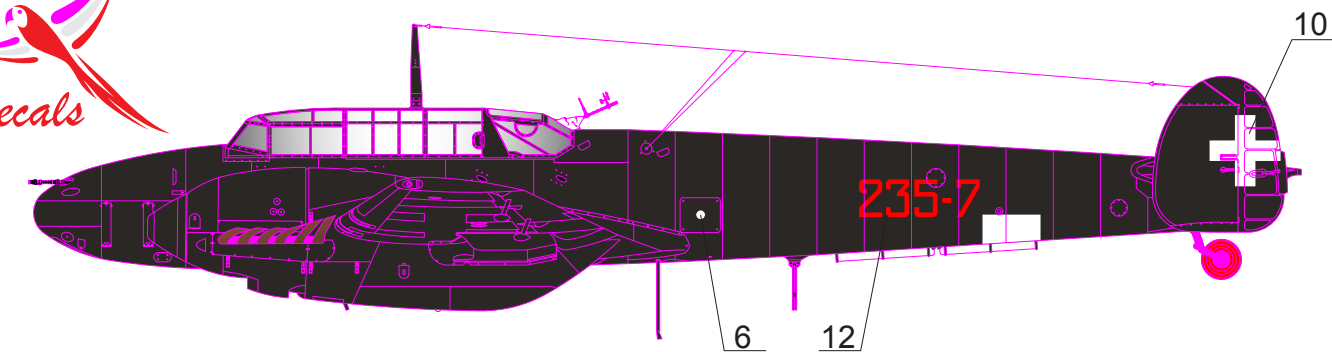

|        |
|--------|
| RLM 22 |
| Bianco |

Messerschmitt Bf 110 C3.  
235ª Squadriglia 60º Gruppo, 41º Stormo,  
Lonate Pozzolo Airfield, Italy Spring 1943

Plane 235-5 (colour photo) had standard German day camouflage (RLM 70/71) with the under surface painted black (RLM 22) for night operations. On the fuselage and on the rudders were traces of cancellation of the previous *Luftwaffe* marking - probably with Italian paints. On the wings and therefore probably also under, despite of the presence of Italian codes, the German crosses are still applied.

Plane 235-6 had standard black overall camouflage only exception are white insignia and the unit code in grey blue. The cancellations of the German codes and insignia, had been made with black paint.

Painting of the plane 235-7 is total reconstruction made by Marco Gueli (there are not available photos) taking as a reference the night camouflage and low visibility insignia adopted from Reggiane Re 2001sCN of the 234th Sq.

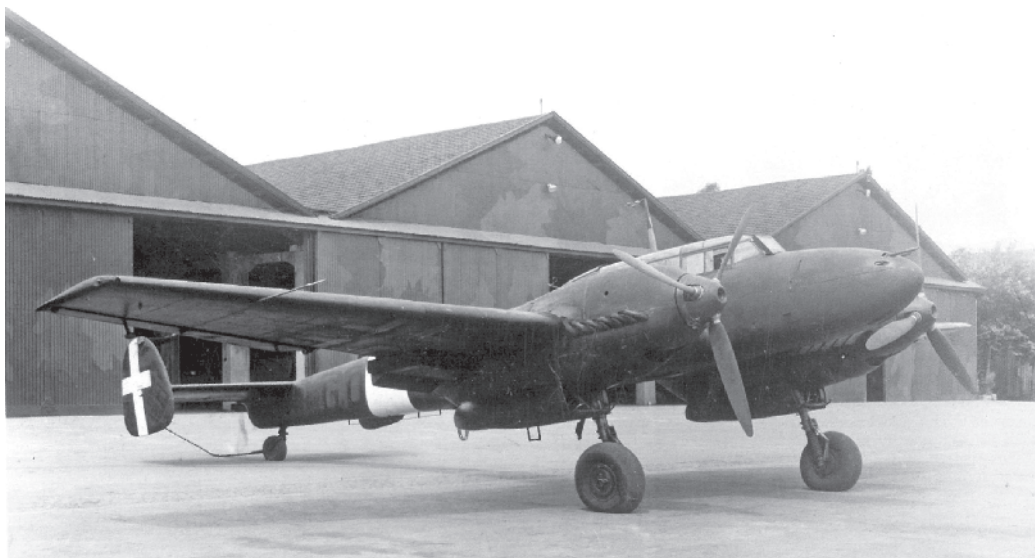

Two images of the same Bf 110, taken at Guidonia in summer 1942, immediately after the Italian insignia were painted on. On the fuselage sides the German codes are still visible.

photo credits: Fabrizio Becchetti & Marco Gueli „Ali Straniere in Italia - Gli Altri Tedeschi” book.

The only one known colour image of a Bf 110C-3 of the Regia Aeronautica. The photo was taken at Lonate Pozzolo (VA) in spring 1943.

