



Bf 109F-2 S.A.

eduard

49 508

1/48 scale detail set for ZVEZDA kit • sada detailů pro model 1/48 ZVEZDA

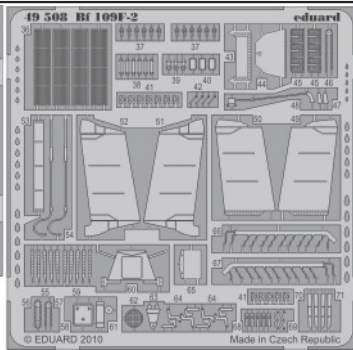
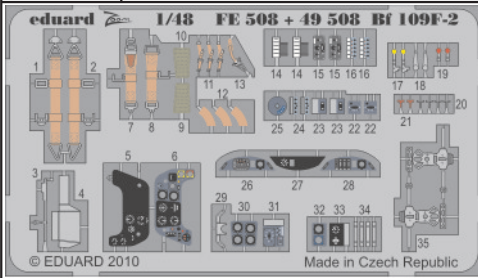

film

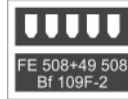

- ★ APPLY EXPRESS MASK AND PAINT BEFORE GLUING
POUŽIT EXPRESS MASK NABARVIT PŘED SLEPENÍM
- ☉ SYMMETRICAL ASSEMBLY
SYMETRICKÁ MONTÁŽ
- REMOVE
ODSTRANIT
- ▨ GRIND
OBROUSIT
- ⊘ DRILL HOLE
VRTAT OTVOR
- ↪ BEND
OHNOUT
- ⊕ OPTION
VOLBA
- Ⓜ REPLACE
NAHRADIT

 ORIGINAL KIT PARTS
PŮVODNÍ DÍLY STAVEBNICE
 PHOTO-ETCHED PARTS
LEPTANÉ DÍLY
 PARTS TO BE REMOVED
DÍLY K ODSTRANĚNÍ
 FILL
TMELIT

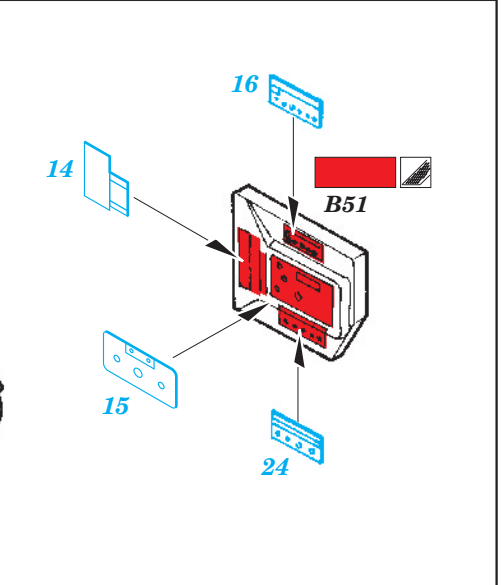
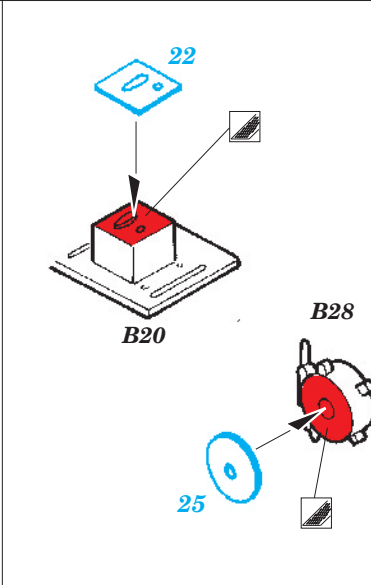
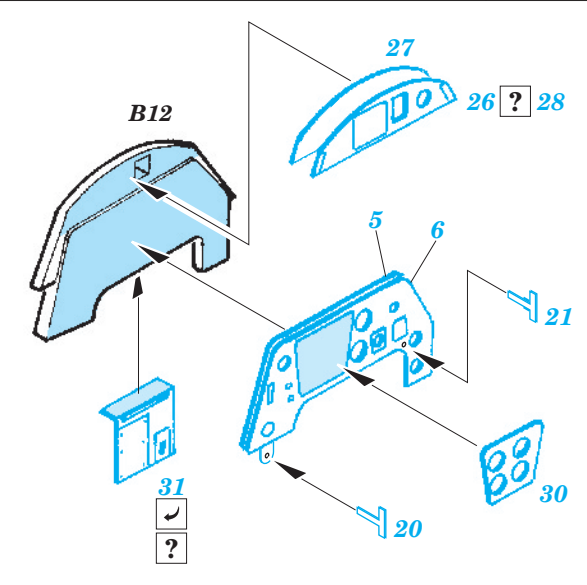
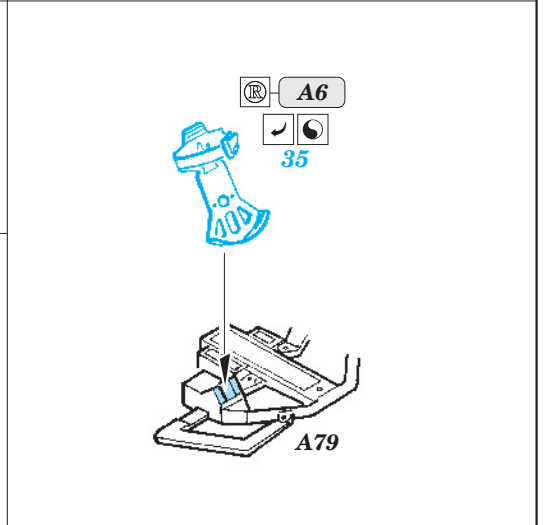
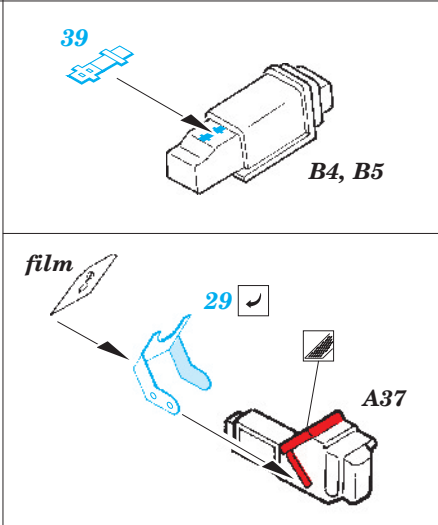
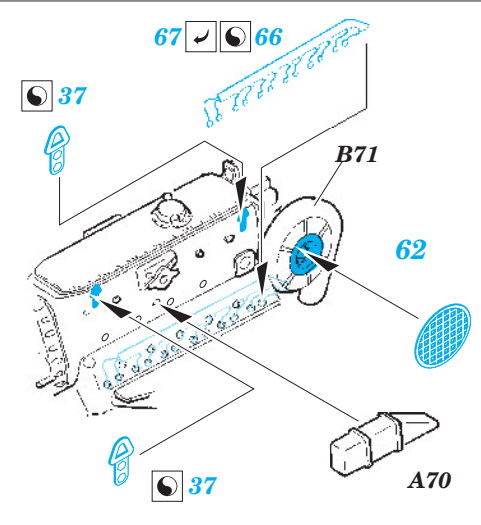
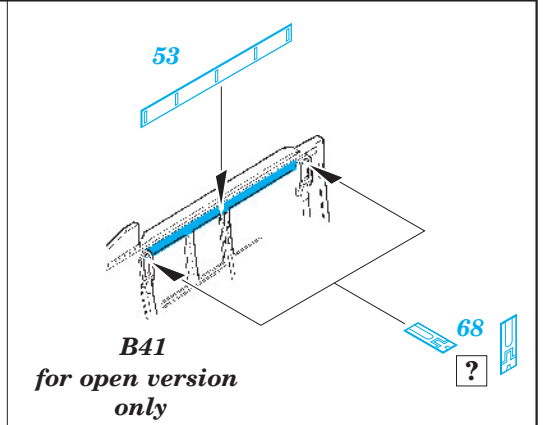
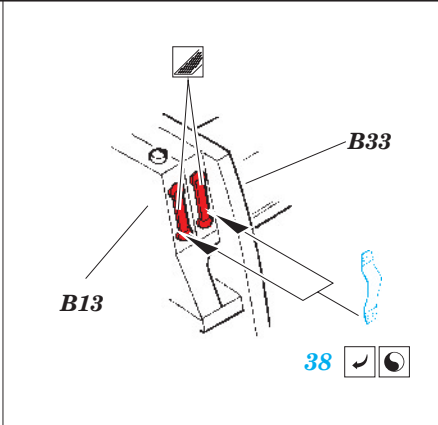
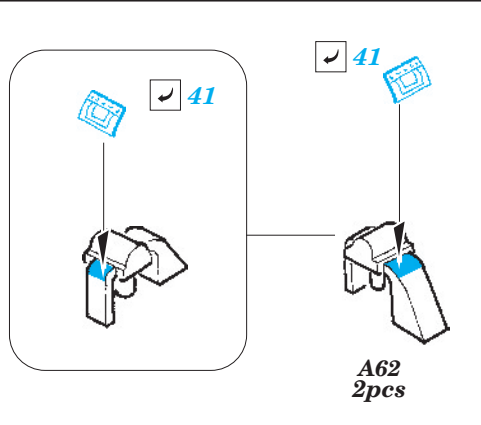

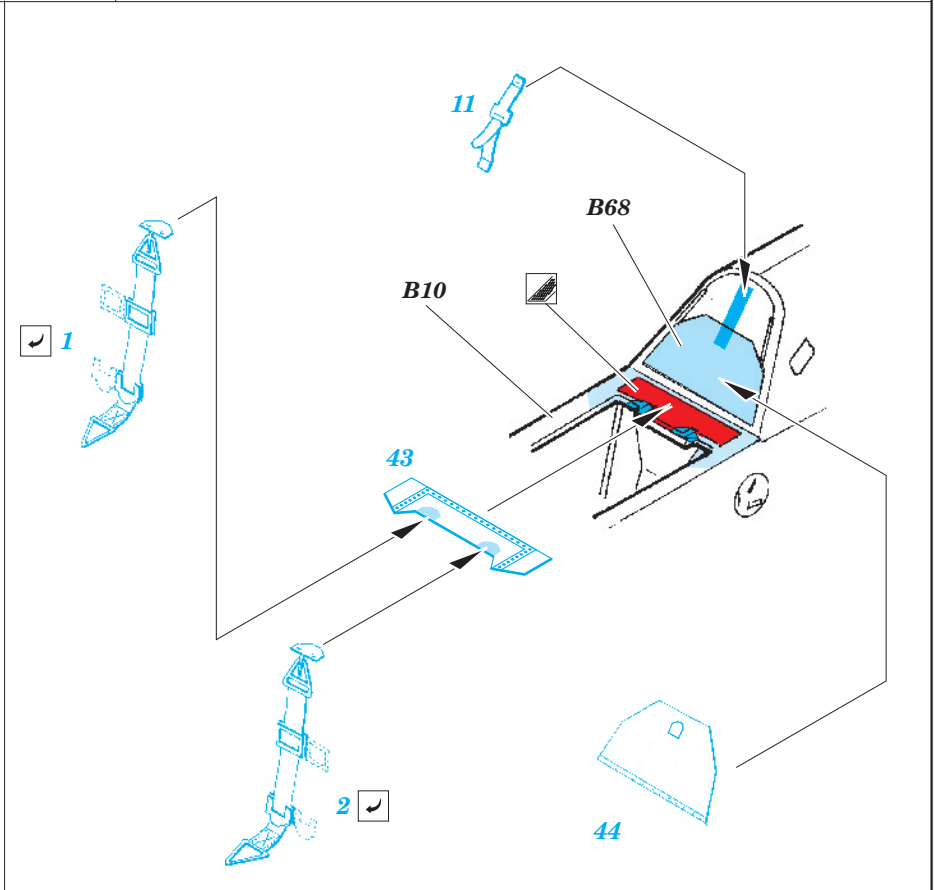
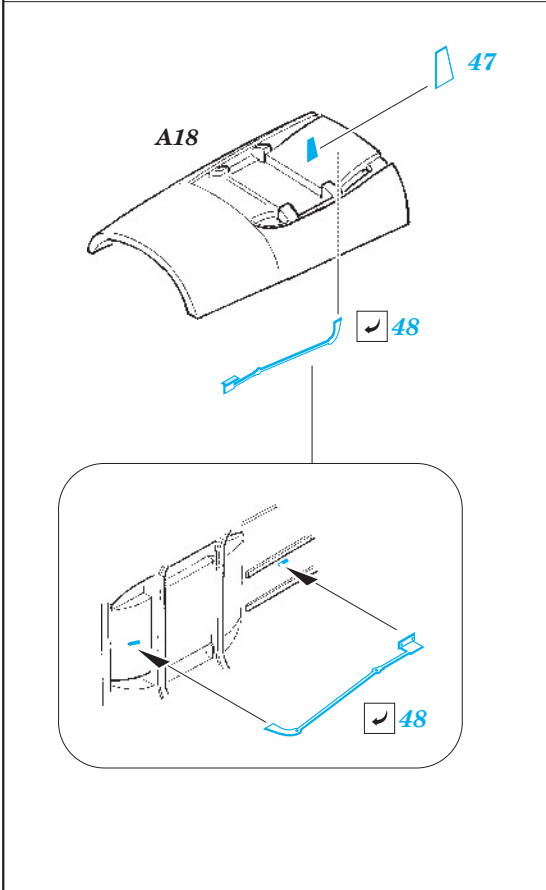
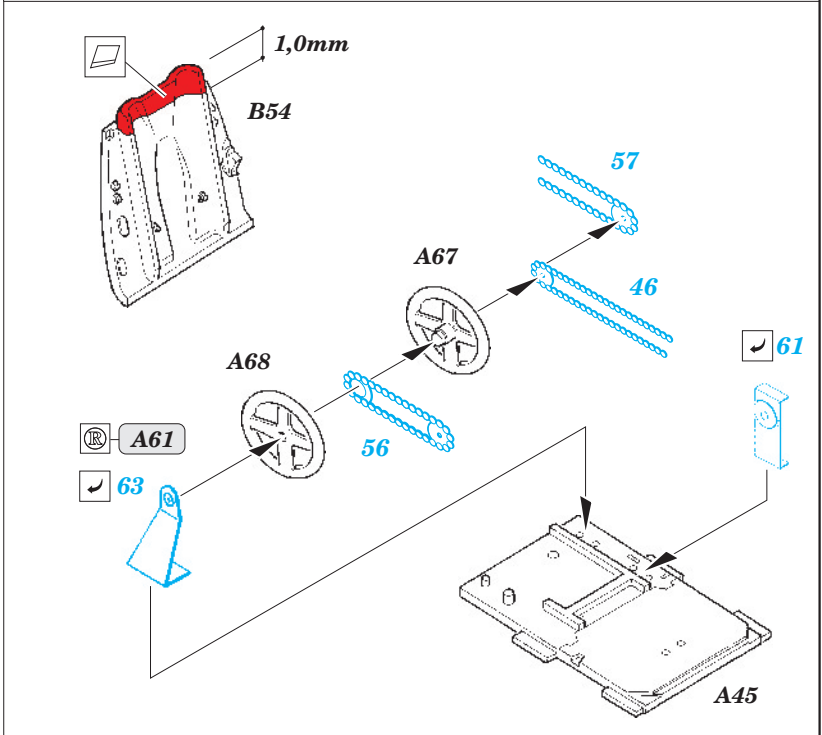
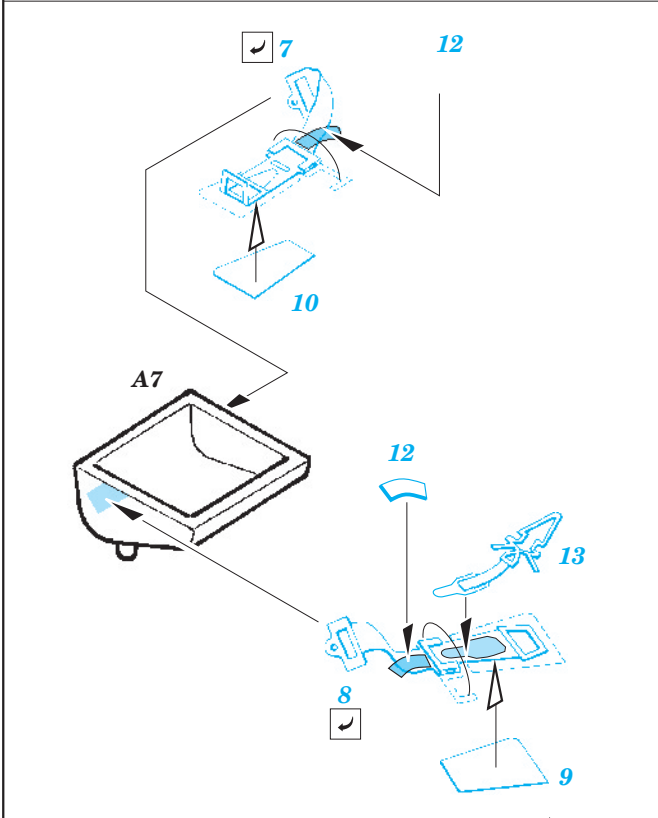
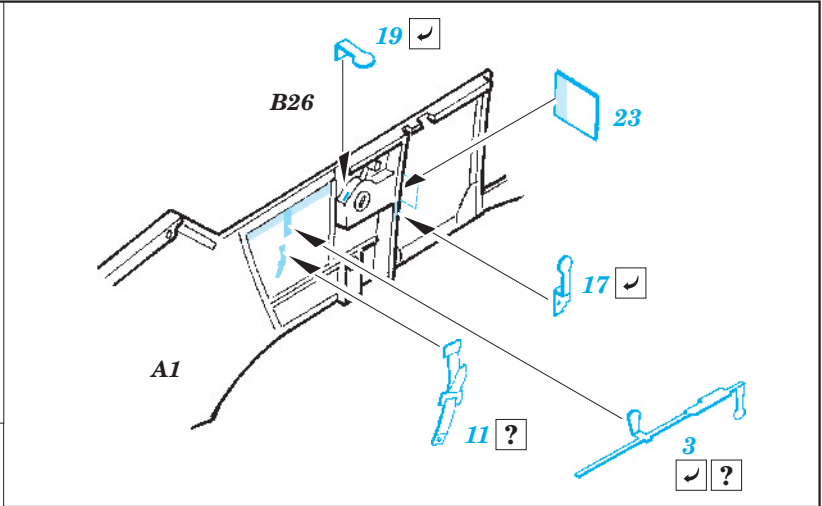
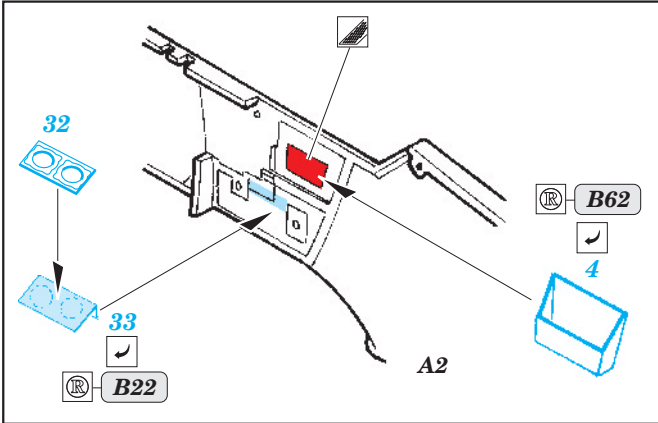

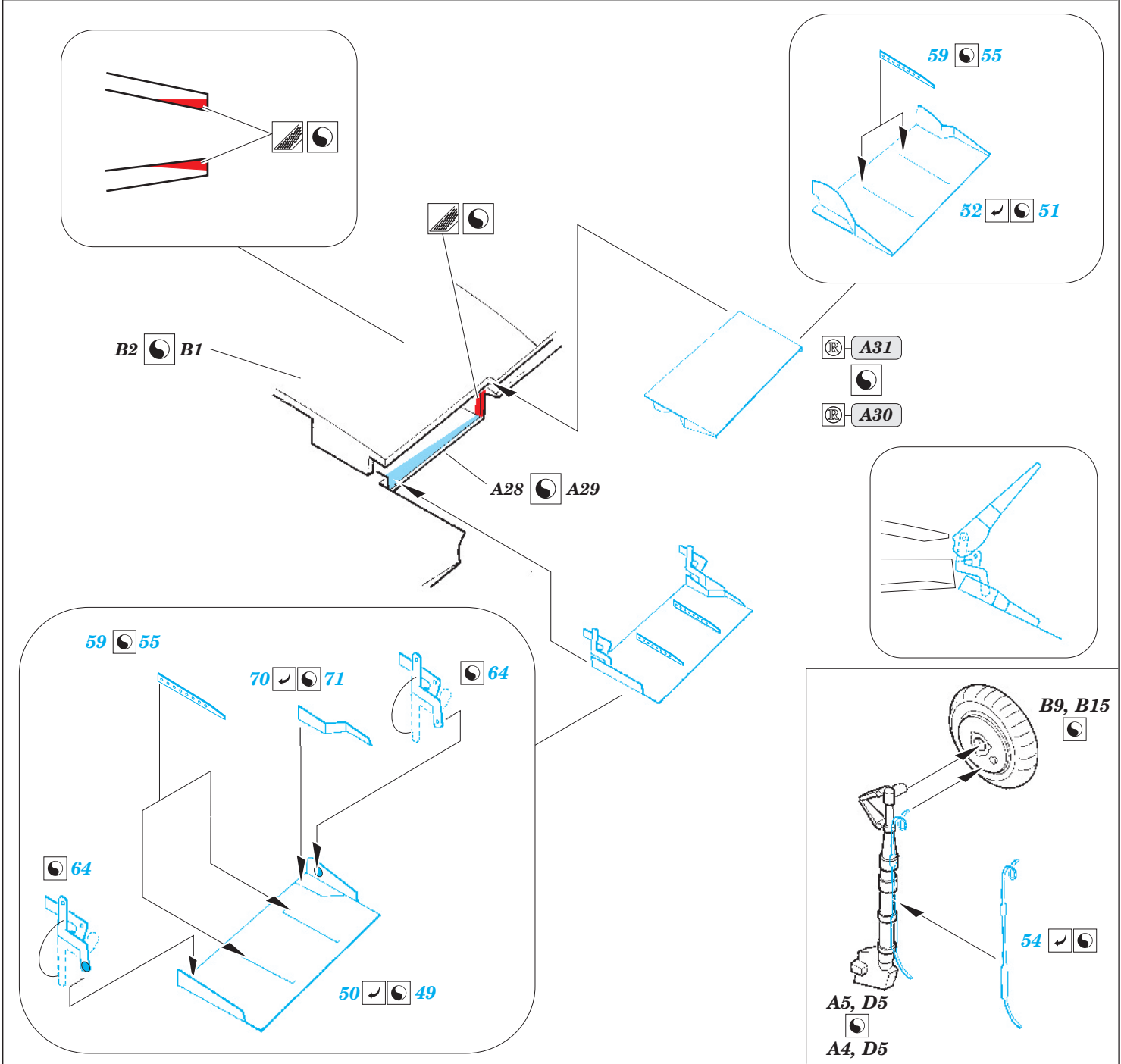
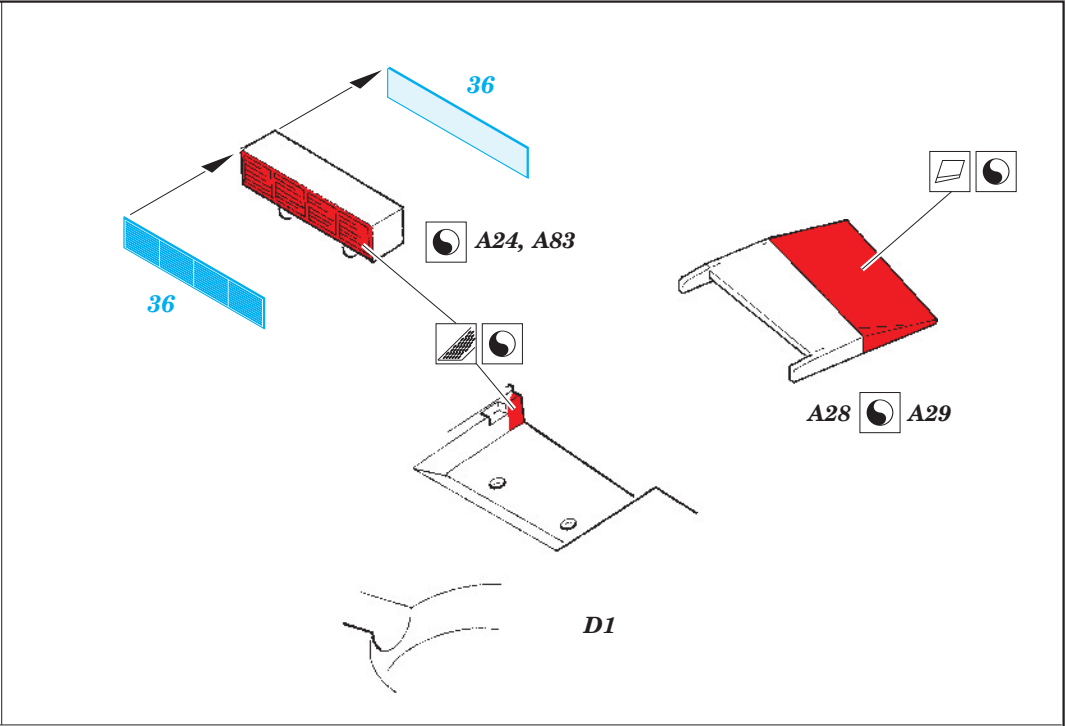
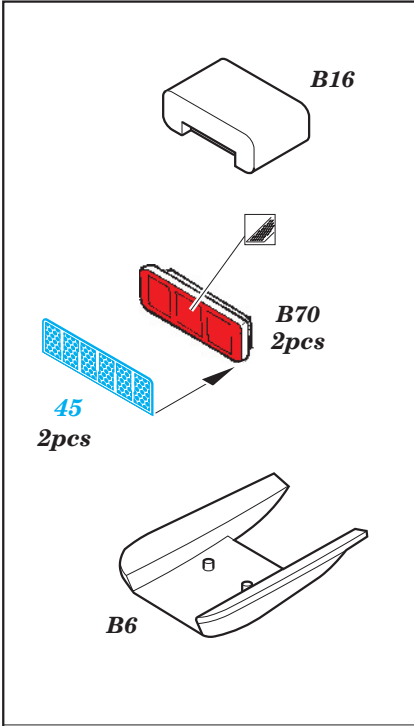

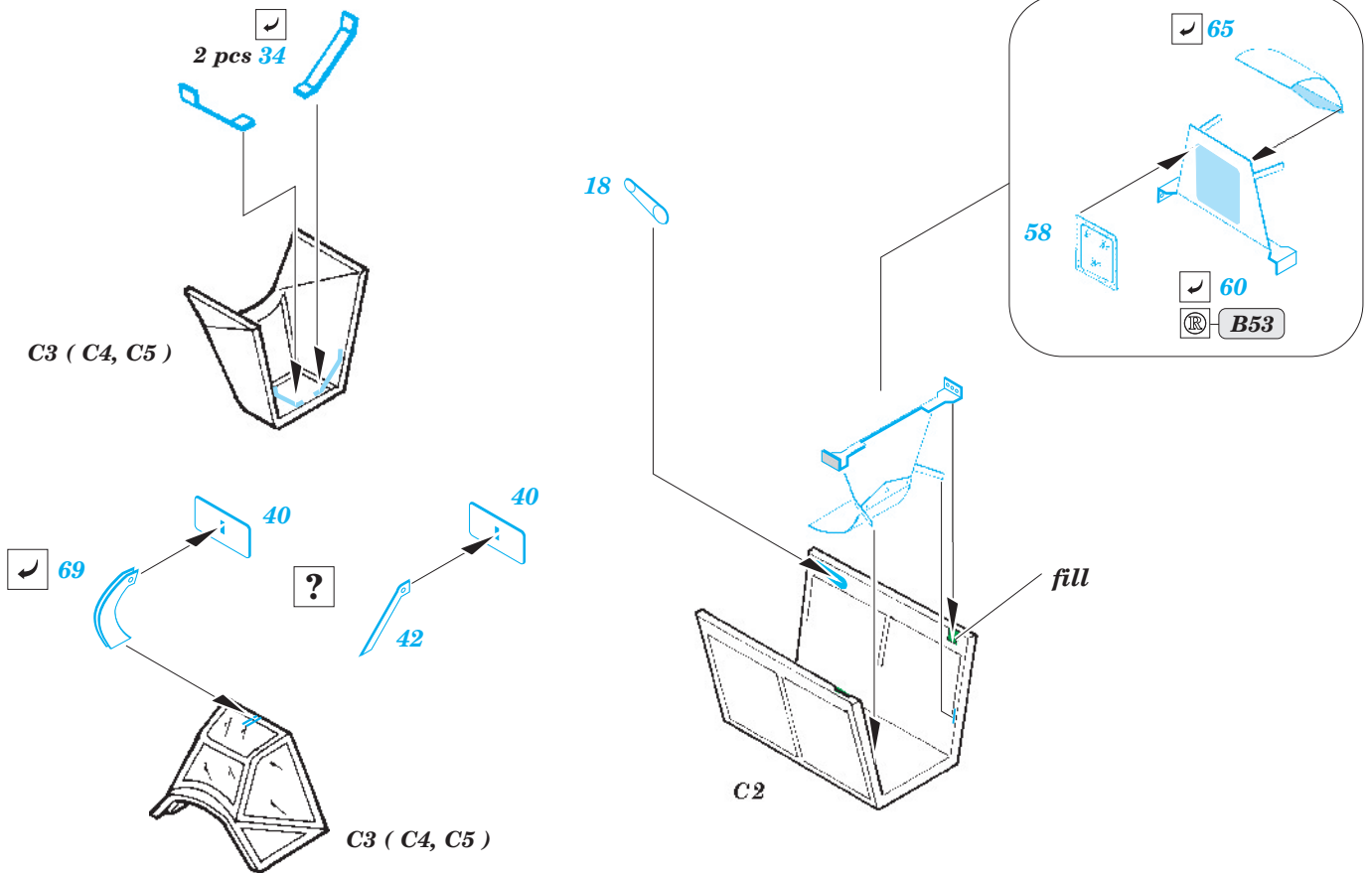

PARTS WITH GLUE • DÍLY OPATŘENÉ LEPIDLEM

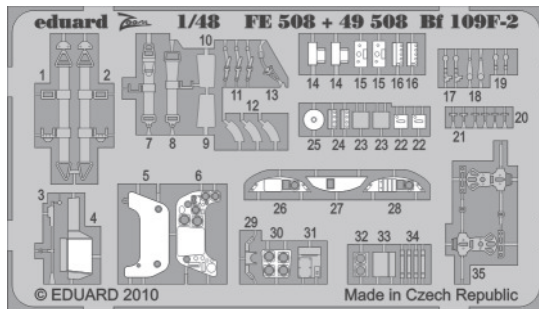

1. Separate the etched components from their frames on the protective paper. Removal from the paper is done only after separation of the parts from the frames.

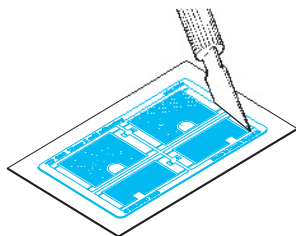

2. Do not inadvertently place etched components on an unwanted surface. Attempts to remove will result in damage to your part.

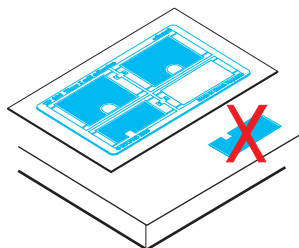

3. Do not touch the adhesive areas of the etched components.
3. Nesahejte na části dílů, na kterých je naneseno lepidlo.



4. Hold the parts by the edges, or at areas free of adhesive.
4. Samolepící díly berte za hrany nebo za části, na kterých není naneseno lepidlo.

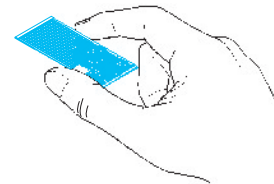

5. Lightly place the component in the desired location and position. Adjust as required. The component will be permanently affixed when pressed onto its intended location, its location can be adjusted.

5. Díl lehce položte do pozice, ve které má být nalepen. Upravte přesnou pozici a přimáčkněte. Díl dokonale přilne až po přimáčknutí, před přimáčknutím lze dílem opatrně manipulovat.

