



1:48 Dogfight Double Supermarine Spitfire Mk.Vb/Messerschmitt Bf 109-E

A50160 SCALE MODEL CONSTRUCTION KIT Spitfire: Wingspan: 232mm Fuselage Length: 195mm | One Decal Scheme Included.

Messerschmitt: Wingspan: 205mm Fuselage Length: 183mm | One Decal Scheme Included.

GB Between June 1940 and November 1942 the small but strategically important island of Malta, situated in the Mediterranean Sea, became the most heavily bombed place on earth when first Italian and then German bombers attempted to force the island to surrender. Merchant shipping convoys were also attacked in an attempt to prevent the island being re-supplied with food and military equipment. Initially Malta's only defending fighter aircraft were outdated Gloster Gladiators and then Hawker Hurricanes but at the height of the battle, cannon armed and tropicalized Spitfire Mk.Vbs were used to intercept the German Junkers Ju88 and Ju87 Stuka dive bombers which were escorted by Messerschmitt Bf109Es. It became a struggle that was in some ways similar to the Battle of Britain. Eventually at the end of 1942, the war in North Africa had been won by the Allies so Malta was no longer of such importance to the Axis powers and the bombing stopped allowing the starving civil population to be re-supplied by sea.

FR Entre juin 1940 et novembre 1942, l'île de Malte, petite mais importante grâce à sa localisation stratégique dans la mer Méditerranée, est devenue le lieu le plus bombardé sur la Terre lorsque des bombardiers italiens puis allemands ont essayé de la forcer à se rendre. Ces derniers ont également attaqué des convois de navires marchands afin d'empêcher le ravitaillement de l'île avec des vivres et du matériel militaire. Au début, les seuls chasseurs disponibles pour défendre Malte étaient des Gloster Gladiator obsolètes puis des Hawker Hurricane mais en pleine bataille des Spitfire Mk.Vb tropicalisés et armés de canons ont intercepté les Junker Ju88 et Stuka Ju87 bombardiers en piqué allemands escortés par des Messerschmitt Bf109E. Cette lutte ressembla en quelque sorte à celle de la bataille d'Angleterre. Finalement, à la fin de 1942, les Alliés avaient remporté la victoire en Afrique du Nord et l'île de Malte n'avait donc plus une telle importance pour les puissances de l'Axe. La cessation des bombardements a permis le ravitaillement par mer de la population affamée.

DE Von Juni 1940 bis November 1942 war die kleine, aber strategisch wichtige Mittelmeerinsel Malta schwersten Bombenangriffen ausgesetzt, mit denen zuerst italienische und anschließend deutsche Bomber versuchten, die Insel zur Kapitulation zu zwingen. Handelsschiffsverbände wurden ebenfalls angegriffen, um die Lieferung von Lebensmitteln und militärischer Ausrüstung nach Malta zu verhindern. Anfangs bestand die einzige Luftabwehr der Insel in veralteten Gloster Gladiators und dann Hawker Hurricanes; auf dem Höhepunkt des Kampfes wurden jedoch mit Kanonen bewaffnete und tropenfesten Spitfires Mk.Vb als Abfangjäger gegen die von der Messerschmitt Bf109E begleiteten deutschen Sturzkampfbomber Junkers Ju88 und Ju87 eingesetzt. Der sich daraus entwickelnde Kampf war der Schlacht um England in so mancher Hinsicht ähnlich. Ende 1942 hatten die Alliierten den Krieg in Nordafrika letztlich gewonnen, weshalb Malta für die Achsenmächte an Bedeutung verlor und das Bombardement aufhörte. Die hungrierende Bevölkerung konnte daraufhin wieder durch Schiffe versorgt werden.

ES Entre junio de 1940 y noviembre de 1942 la pequeña isla de Malta, de gran importancia estratégica por su situación en el Mediterráneo, se convirtió en el lugar más bombardeado del planeta cuando los bombarderos italianos y alemanes trataron de forzar la rendición. También fueron atacados los convoyes mercantes, en un intento por evitar que la isla fuese provista de alimentos y equipamiento militar. En los primeros momentos, las únicas aviones disponibles como defensa eran anticuadas unidades Gloster Gladiator y, posteriormente, Hawker Hurricane, pero, en el momento de mayor intensidad de los combates, se utilizaron Spitfire Mk.Vb para interceptar los bombarderos alemanes Junker Ju88 y Ju87 Stuka, escoltados por Messerschmitt Bf109E. En algunos aspectos fue un escenario bélico similar a la Batalla de Inglaterra. A finales de 1942 los aliados habían ganado la guerra en el Norte de África, por lo que Malta dejó de tener tanta importancia para las potencias del Eje y se finalizaron los bombardeos, permitiendo a la famélica población civil recibir de nuevo suministros por mar.

SE Från juni 1940 till november 1942 blev den lilla men strategiskt viktiga medelhavsön Malta den mest bombade platsen i världen när först italienska och därefter tyska bombplan försökte driva fram en kapitulering. Även transportkonvojer till sjöss attackerades i syfte att strypa tillförseln av livsmedel och militär utrustning till ön. Inledningsvis försvarades Malta endast av föråldrade jaktplan i form av Gloster Gladiators och därefter Hawker Hurricanes, men under de kraftiga striderna använde man kulsprutebestyckade Spitfire Mk.Vb-plan för att attackera de tyska störbombarna Junkers Ju88 och Ju87 Stuka, som eskorterades av Messerschmitt Bf109E-plan. Striderna påminde i vissa aspekter om Slaget om Storbritannien. I slutet på 1942 stod slutligen de allierade som segrare i Nordafrika, vilket betydde att Malta inte längre var av så stor betydelse för axelmakterna. Bombningen upphörde, vilket betydde att den svältande civilbefolkningen kunde utföras från sjöss.

Specification: Supermarine Spitfire Mk.Vb

Speed: 370mph (595km/h)

Range: 470m (760km)

Wingspan: 36ft. 10in. (11.23m)

Length: 29 ft. 11 in (9.12 m)

Armament: 2 x 20mm cannon & 4 x .303in Machine Guns

Specification: Messerschmitt Bf 109E-7

Speed: 323mph (520km/h)

Range: 410m (660km)

Wingspan: 32ft. 5in. (9.86m)

Length: 28ft. 4in. (8.63m)

Armament: 2 x 20mm MG FF cannons & 2 x 7.9mm MG 17 machine guns

Specification: Supermarine Spitfire Mk.Vb

Vitesse : 595 km/h

Autonomie : 760 km

Envergure : 11,23 m

Longueur : 9,12 m

Armement : 2 canons de 20 mm et 4 mitrailleuses de 7,7 mm

Specification: Messerschmitt Bf 109E-7

Vitesse : 520 km/h

Autonomie : 660 km

Envergure : 9,86 m

Longueur : 8,63 m

Armement : 2 canons MG FF de 20 mm et 2 mitrailleuses MG 17 de 7,9 mm

Specification: Supermarine Spitfire Mk.Vb

Geschwindigkeit: 595 km/h

Reichweite: 760 km

Spannweite: 11,23 m

Länge: 9,12 m

Bewaffnung: 2 x 20 mm Kanonen und 4 x 7,7 mm Maschinengewehre

Specification: Messerschmitt Bf 109E-7

Geschwindigkeit: 520 km/h

Reichweite: 660 km

Spannweite: 9,86 m

Länge: 8,63 m

Bewaffnung: 2 x 20 mm MG FF Kanonen und 2 x 7,9 mm MG 17 Maschinengewehre

Specification: Supermarine Spitfire Mk.Vb

Velocidad: 595 km/h

Autonomía: 760 km

Envergadura: 11,23 m

Longitud: 9,12 m

Armamento: 2 cañones de 20 mm y 4 ametralladoras de 7,7 mm

Specification: Messerschmitt Bf 109E-7

Velocidad: 520 km/h

Autonomía: 660 km

Envergadura: 9,86 m

Longitud: 8,63 m

Armamento: 2 cañones MG FF de 20 mm y 2 ametralladoras MG 17 de 7,9 mm

Specification: Supermarine Spitfire Mk.Vb

Hastighet: 595 km/h

Räckvidd: 760 km

Spännvidd: 11,23 m

Längd: 9,12 m

Bestyckning: två 20 mm-automatkanoner och fyra 7,7 mm-kulsprutor

Specification: Messerschmitt Bf 109E-7

Hastighet: 520 km/h

Räckvidd: 660 km

Spännvidd: 9,86 m

Längd: 8,63 m

Bestyckning: två 20 mm MG FF-automatkanoner och två 7,9 mm MG 17-kulsprutor

FOR BEST RESULTS:

Surfaces to be painted should be clean — before parts are removed from the sprue, wash in warm, soapy water, rinse and dry thoroughly. Stir paints thoroughly before use.

PLEASE NOTE:

Some parts in the kit may not be required to build the model specified.

**HORNBY
HOBBIES**



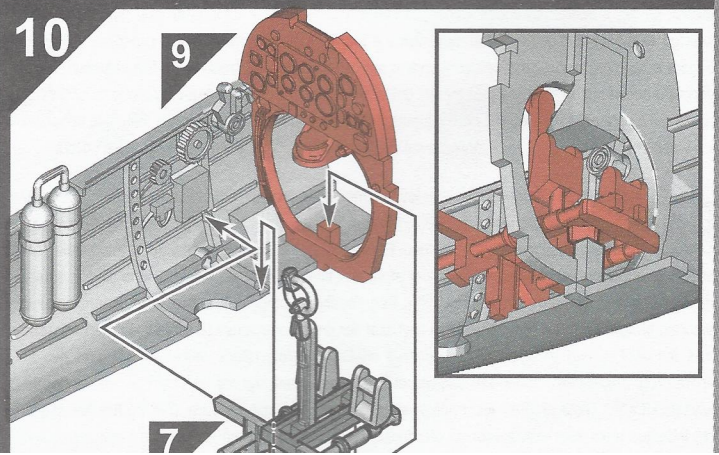
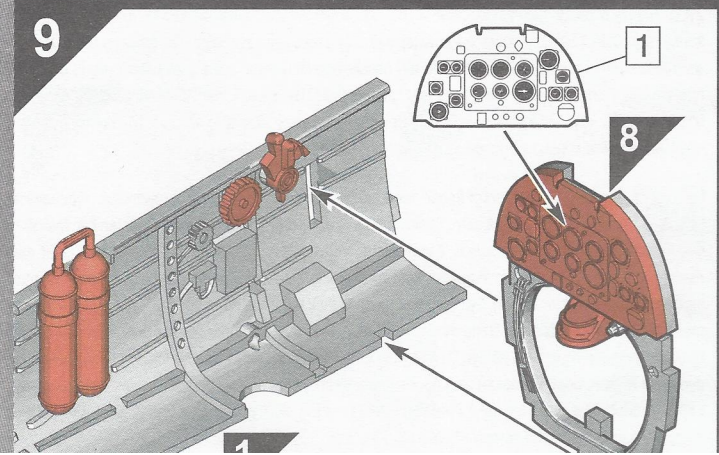
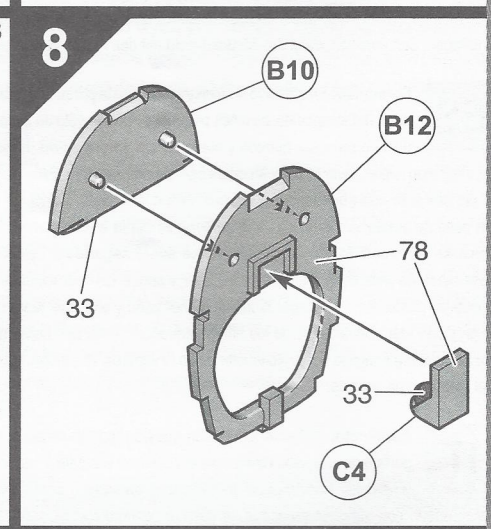
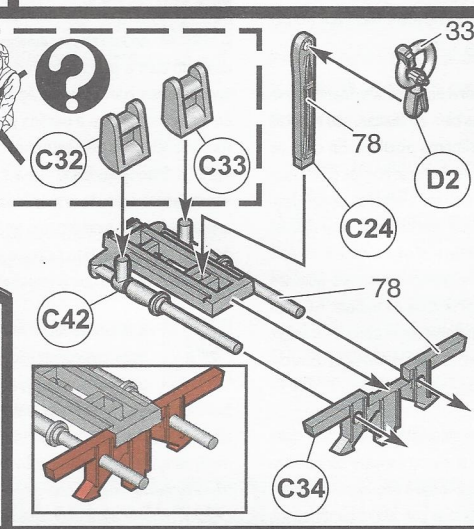
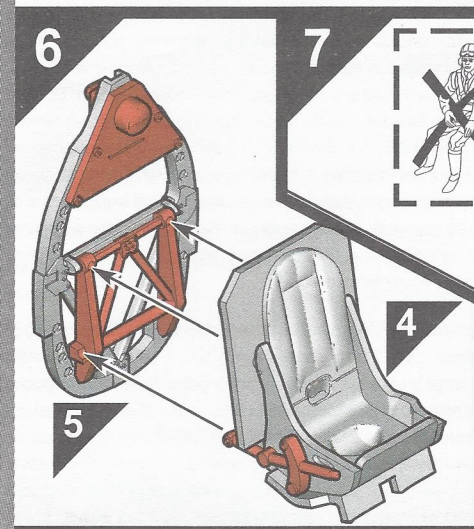
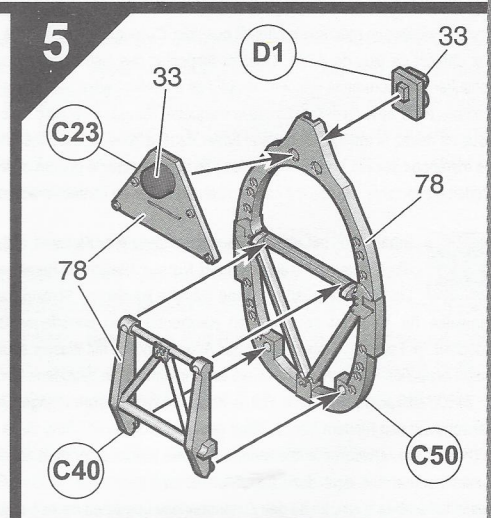
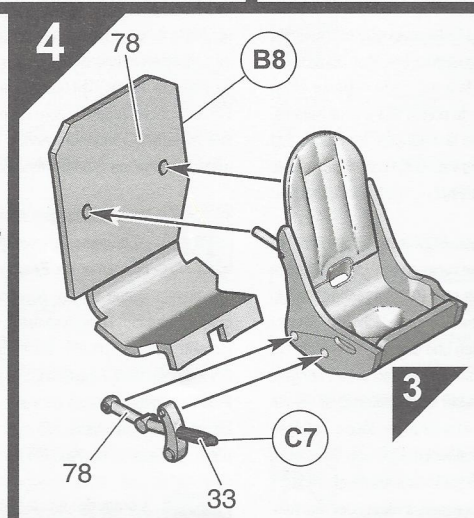
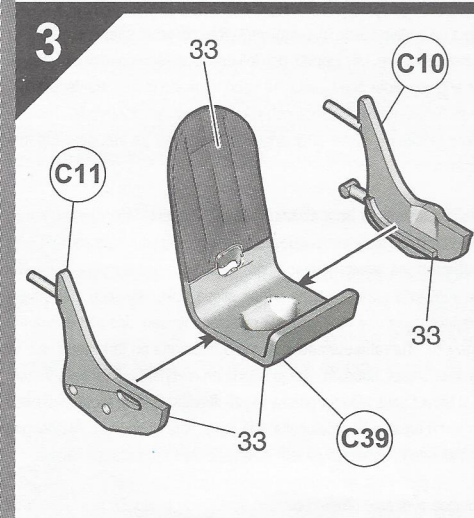
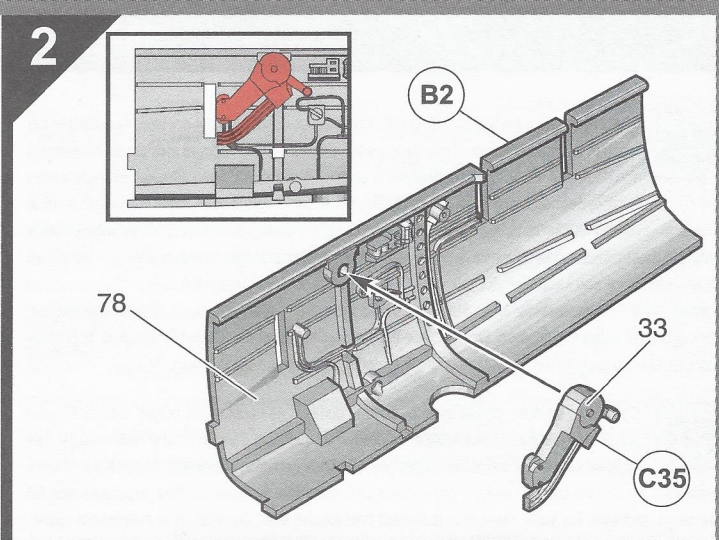
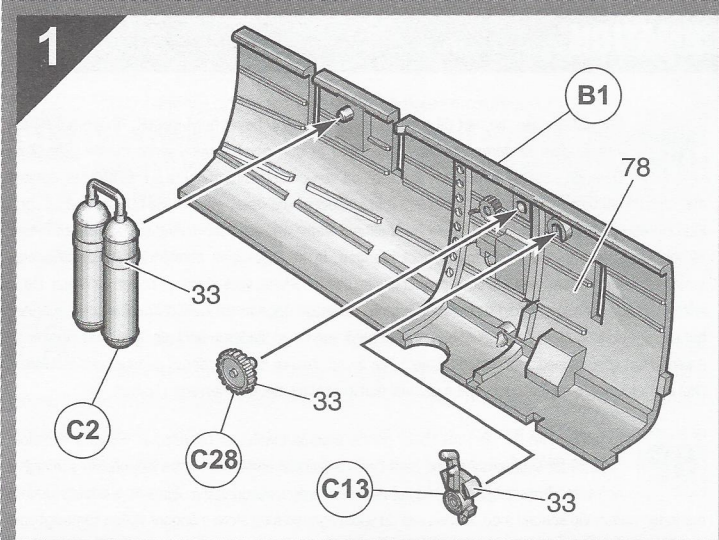

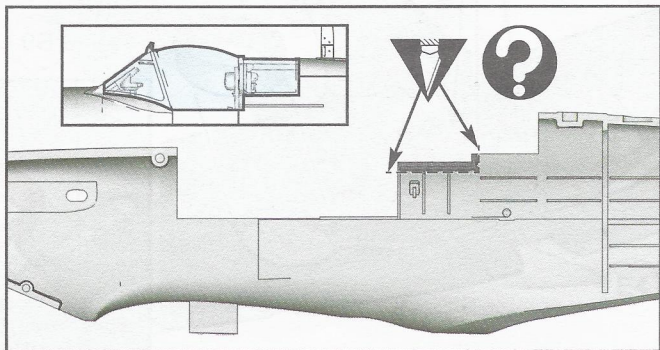
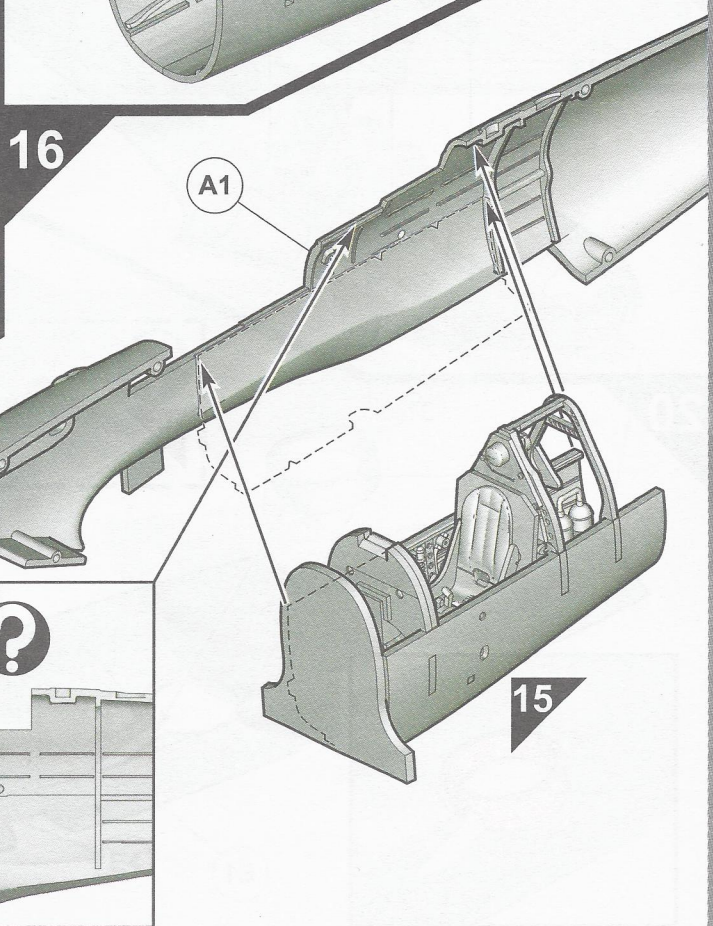
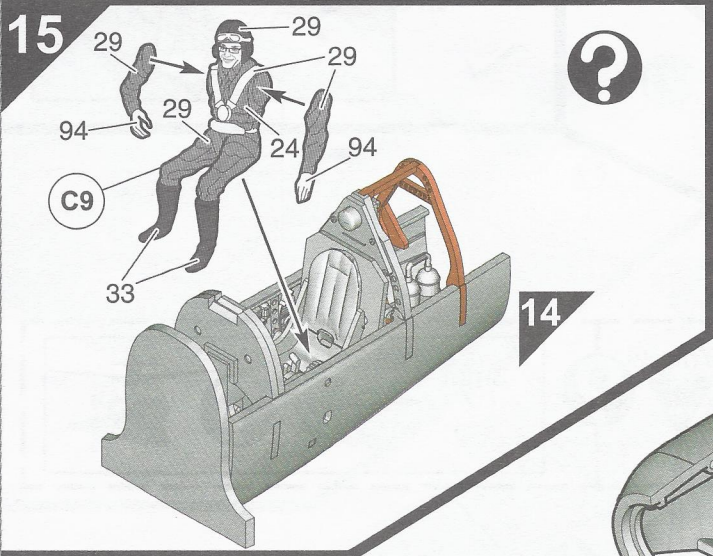
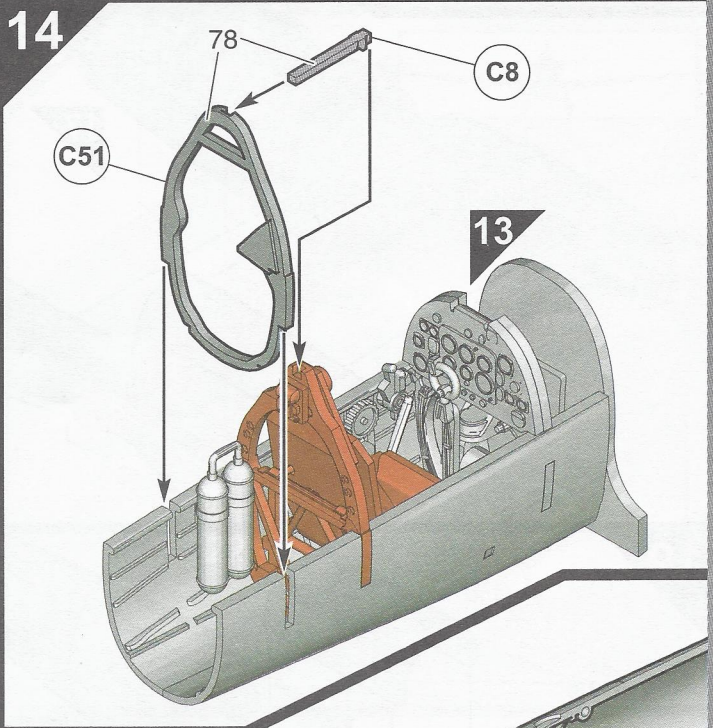
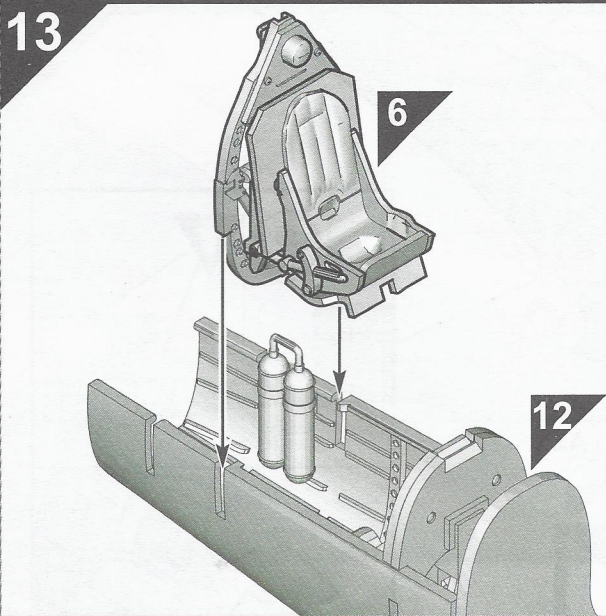
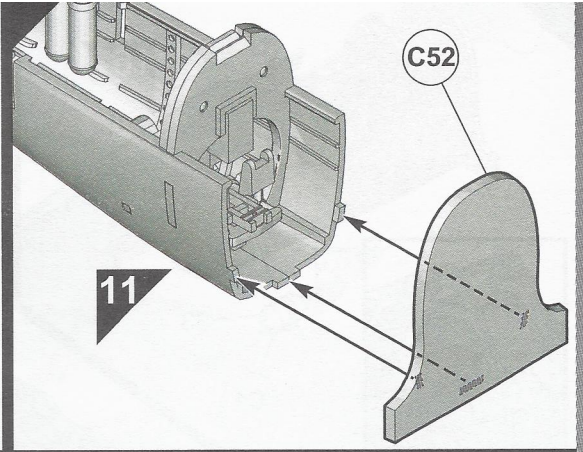
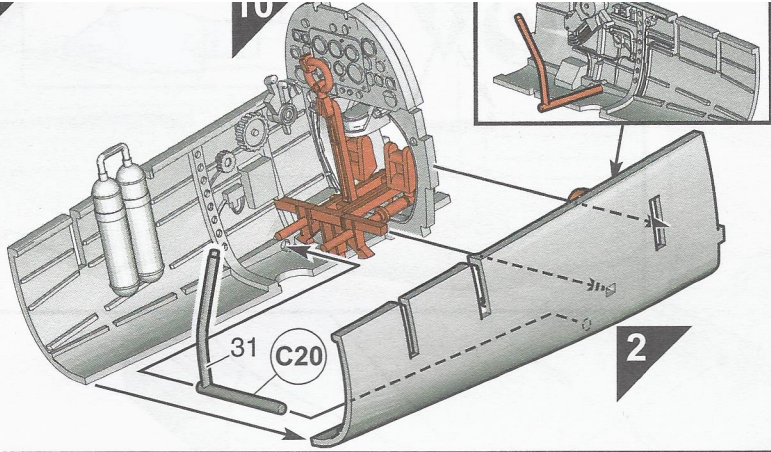

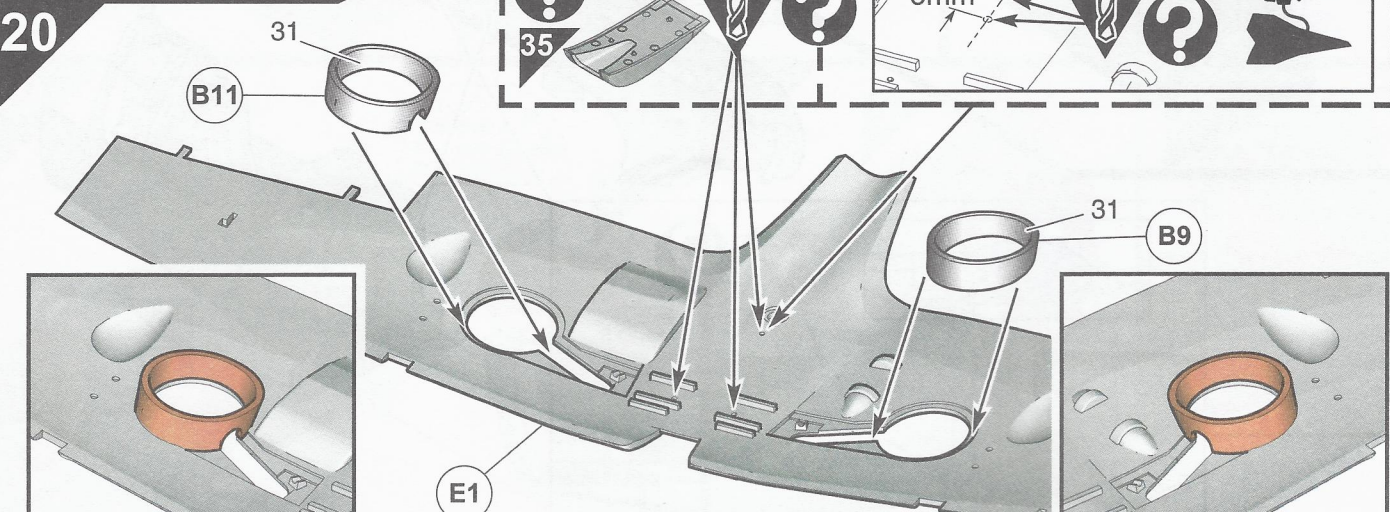
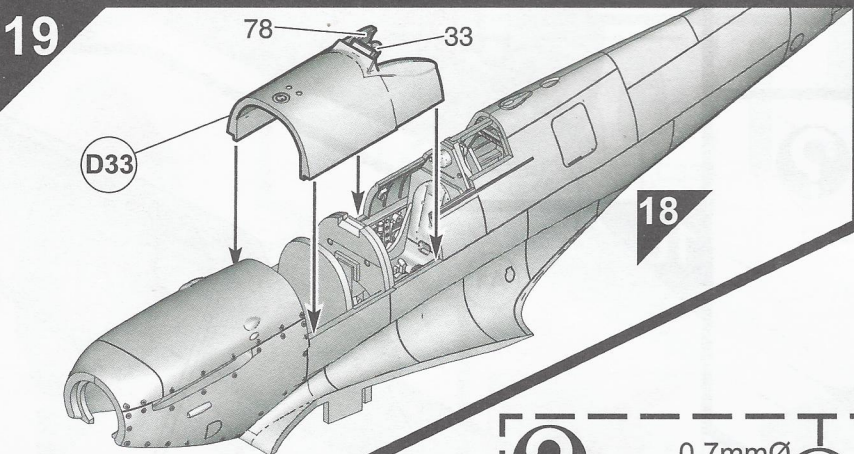
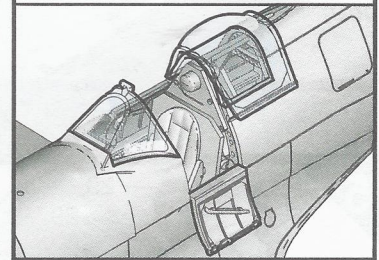
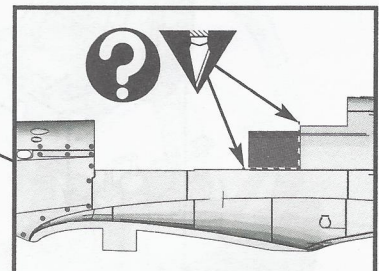
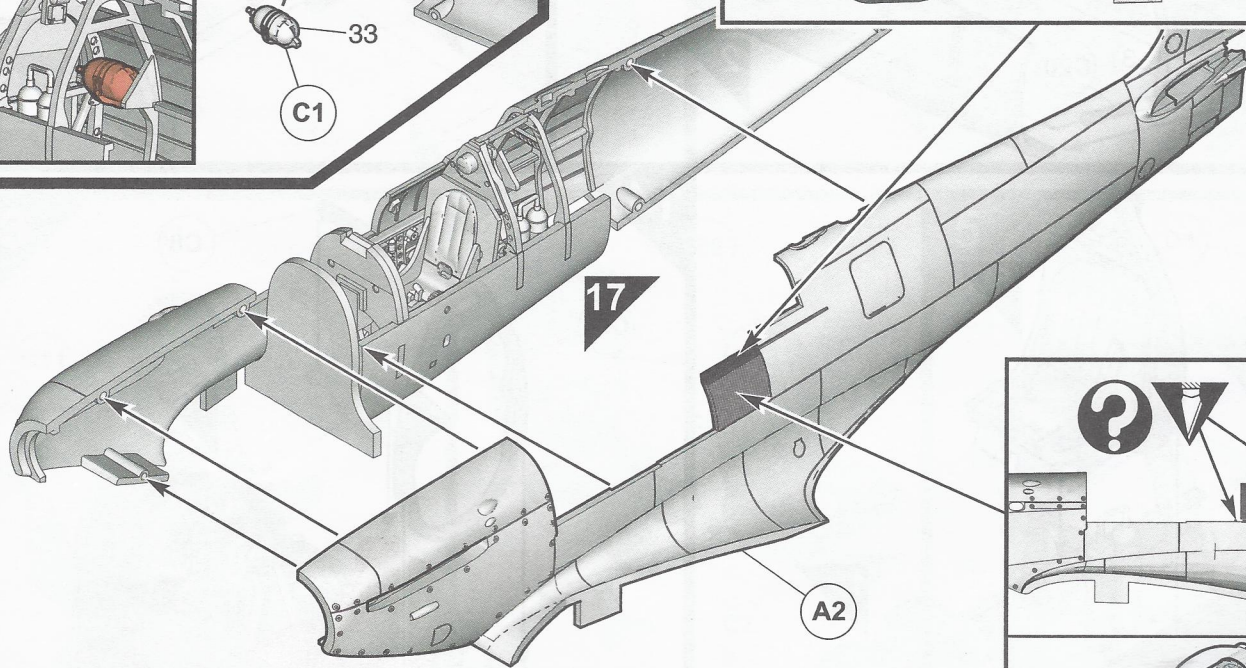
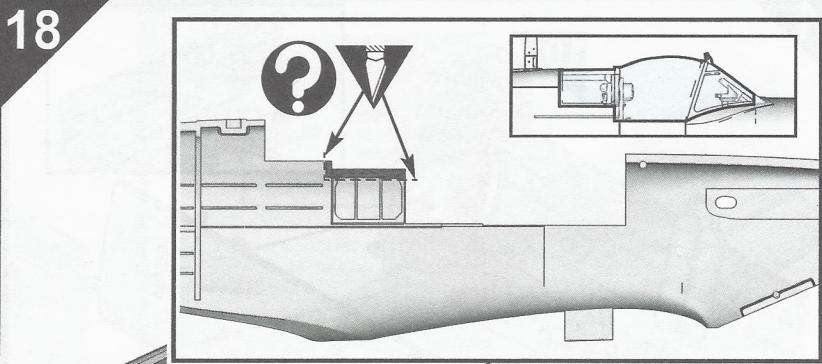
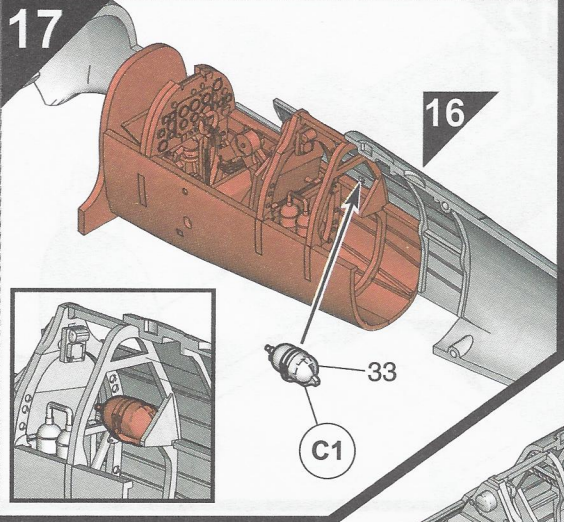

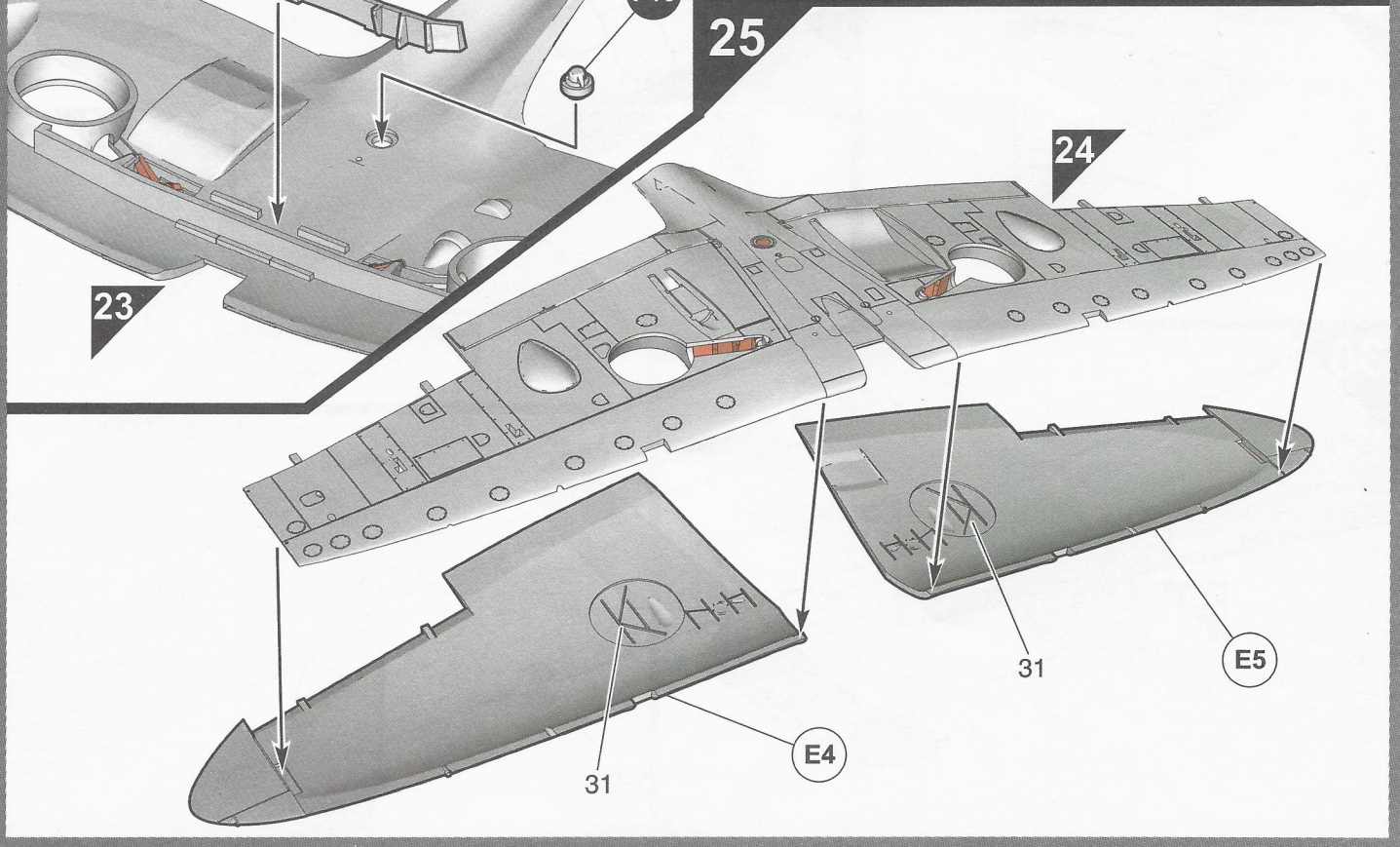
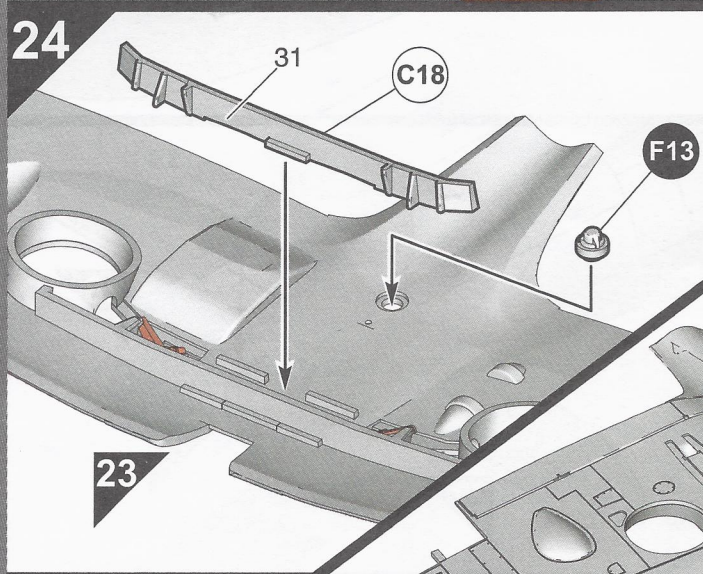
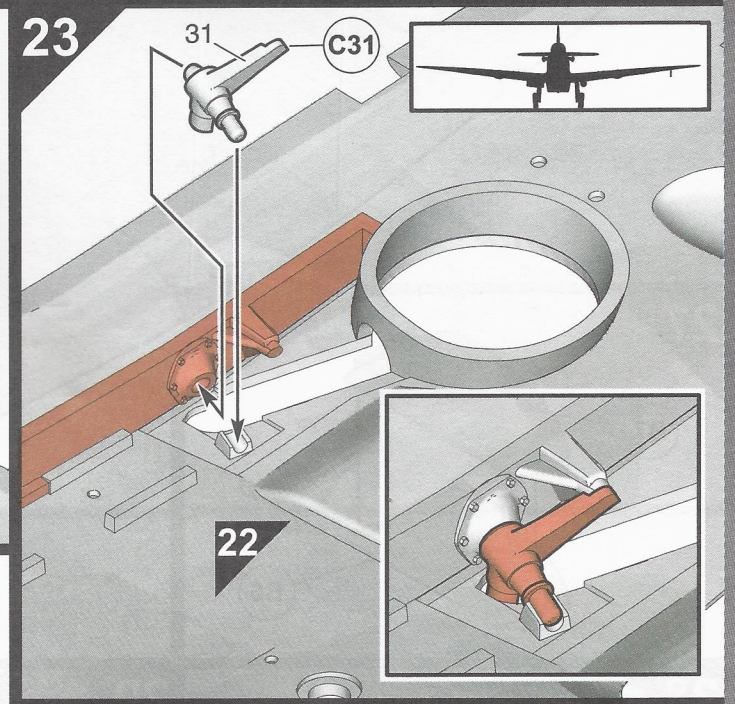
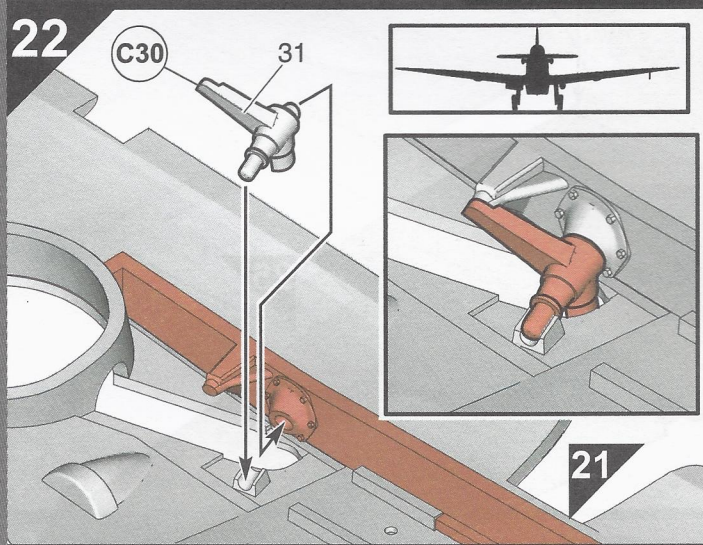
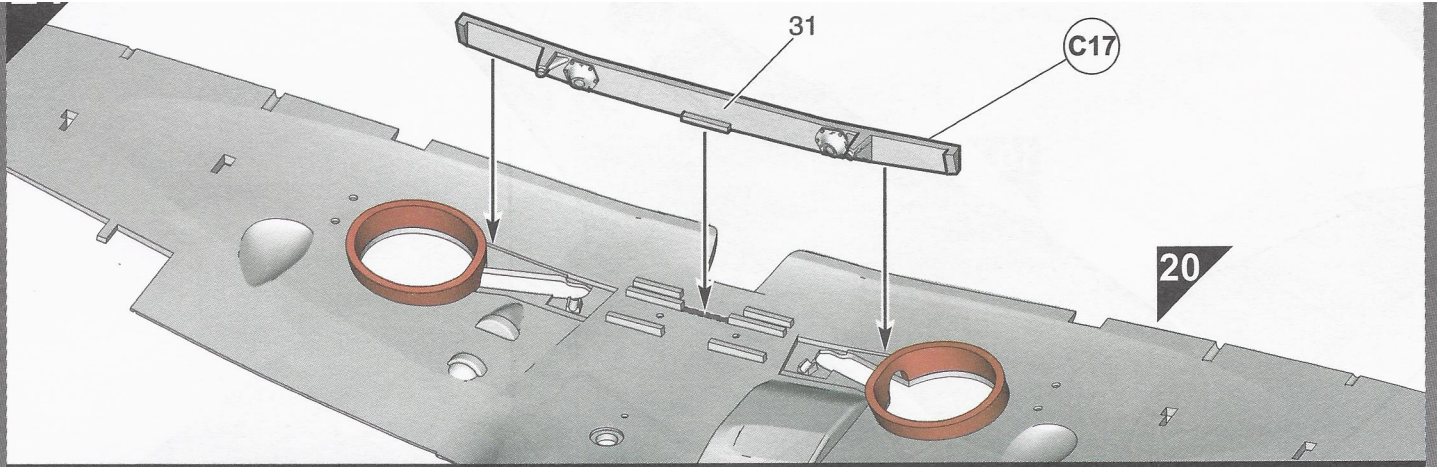

26

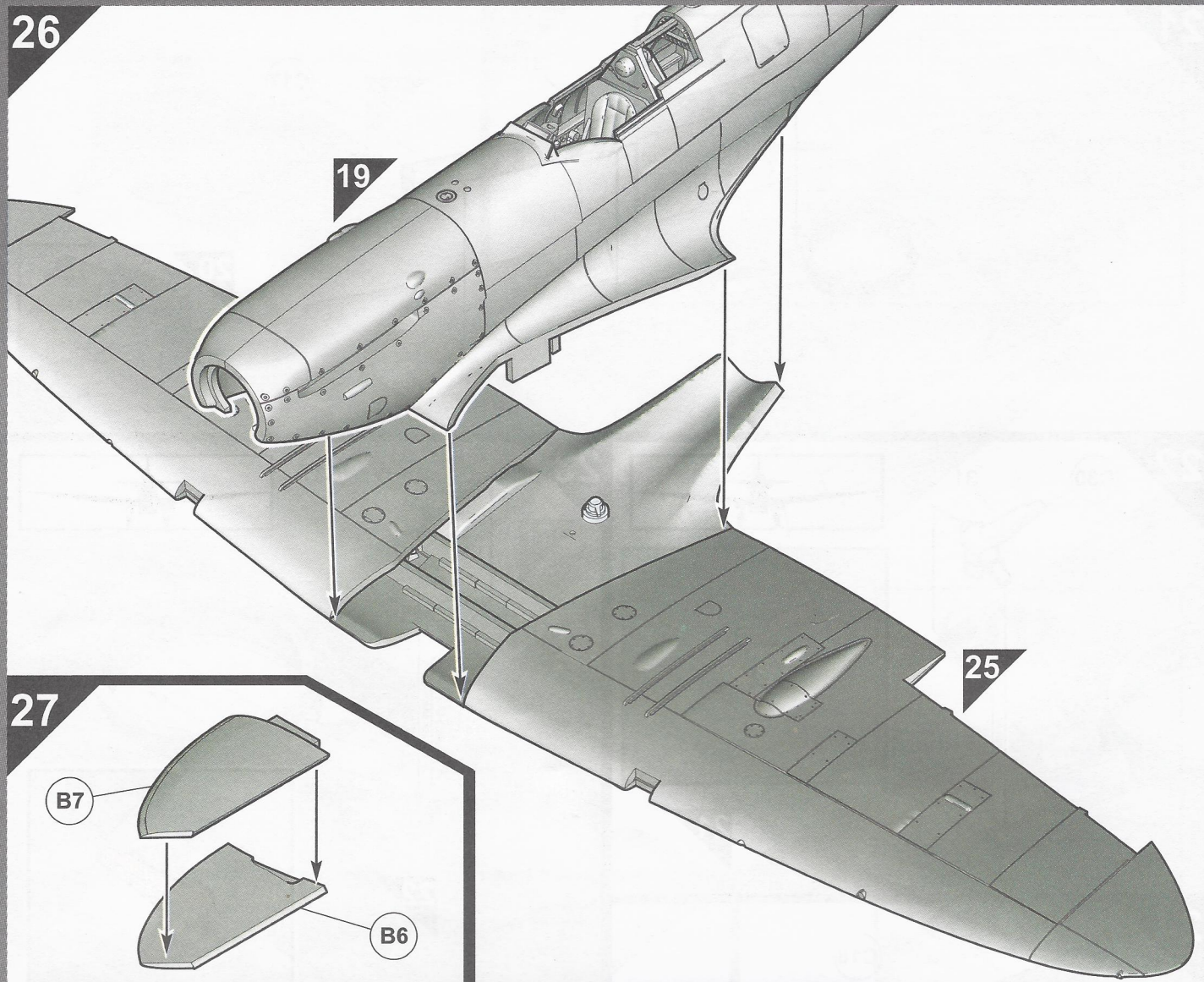

27

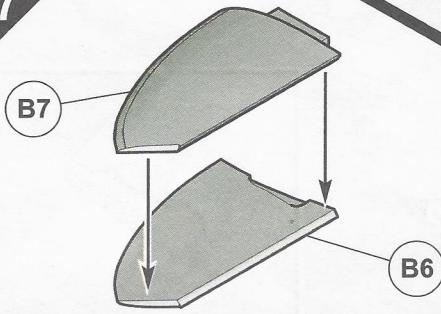

28

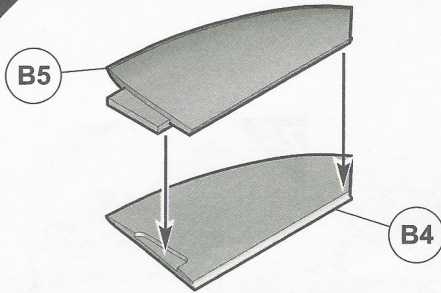

29

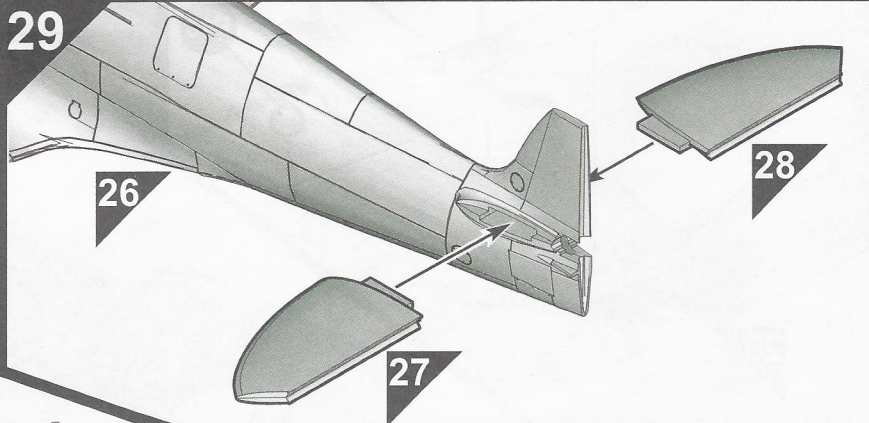

30

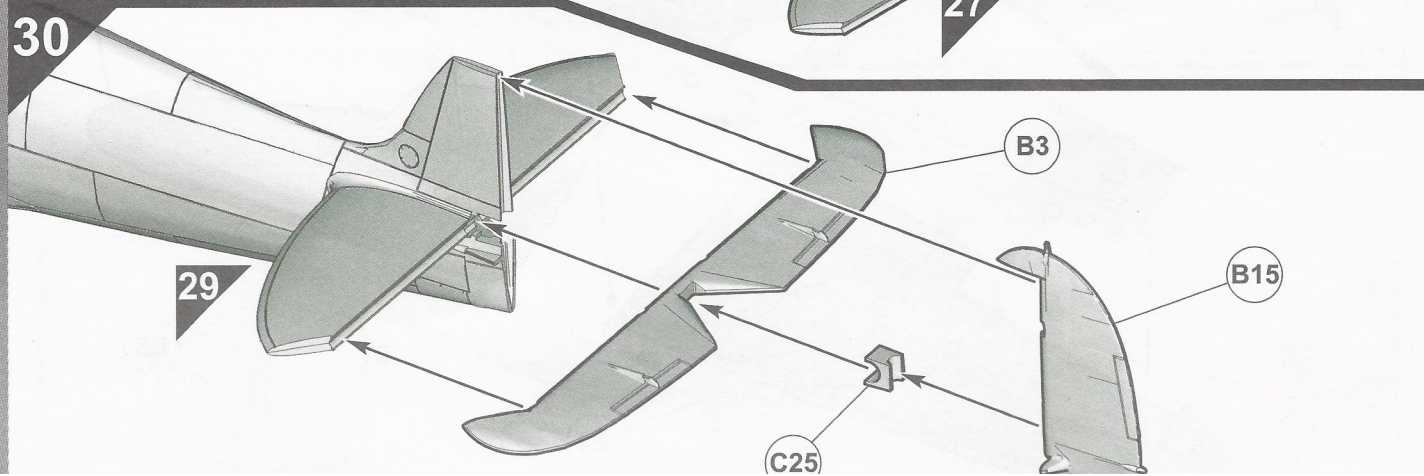

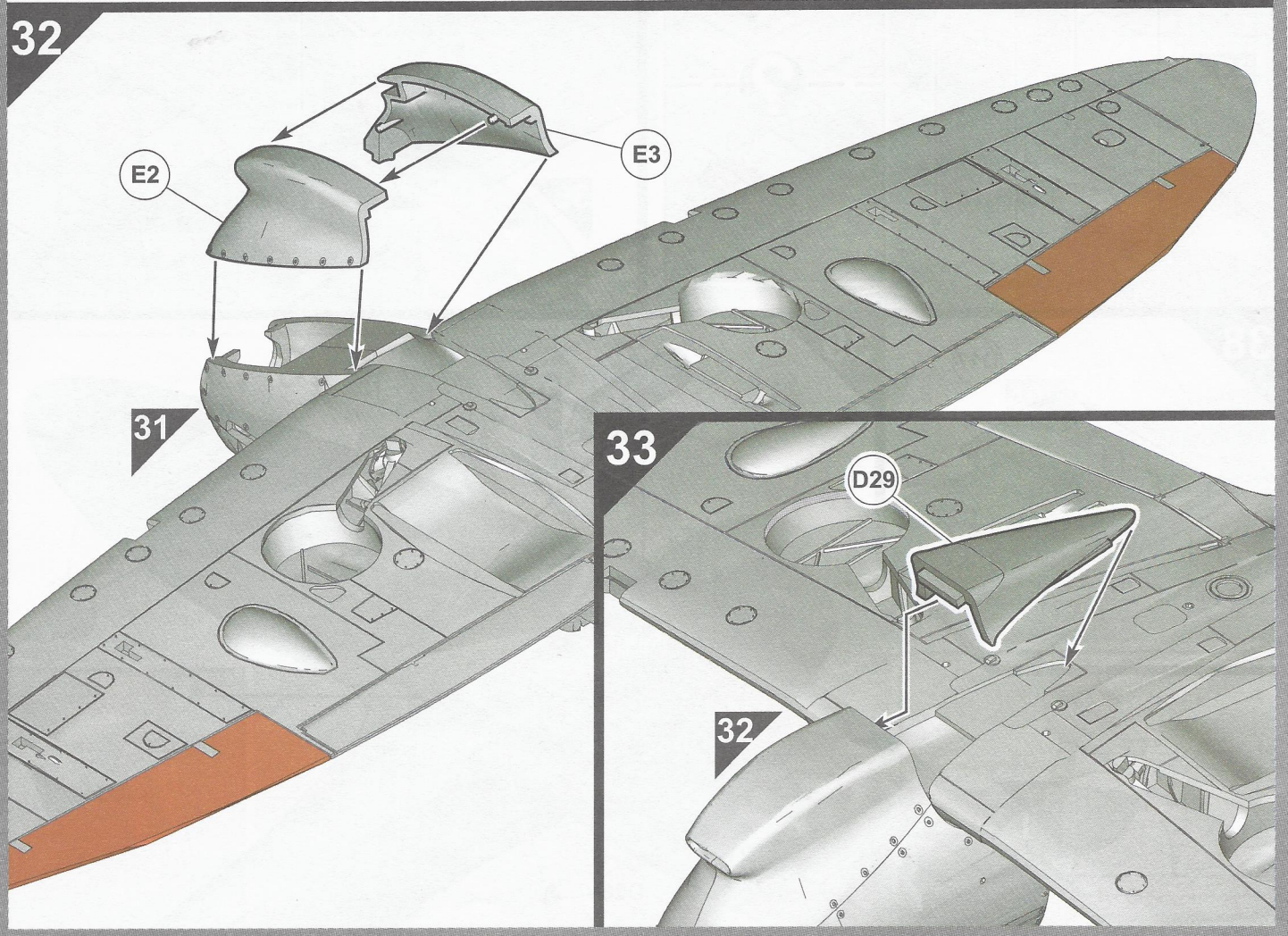
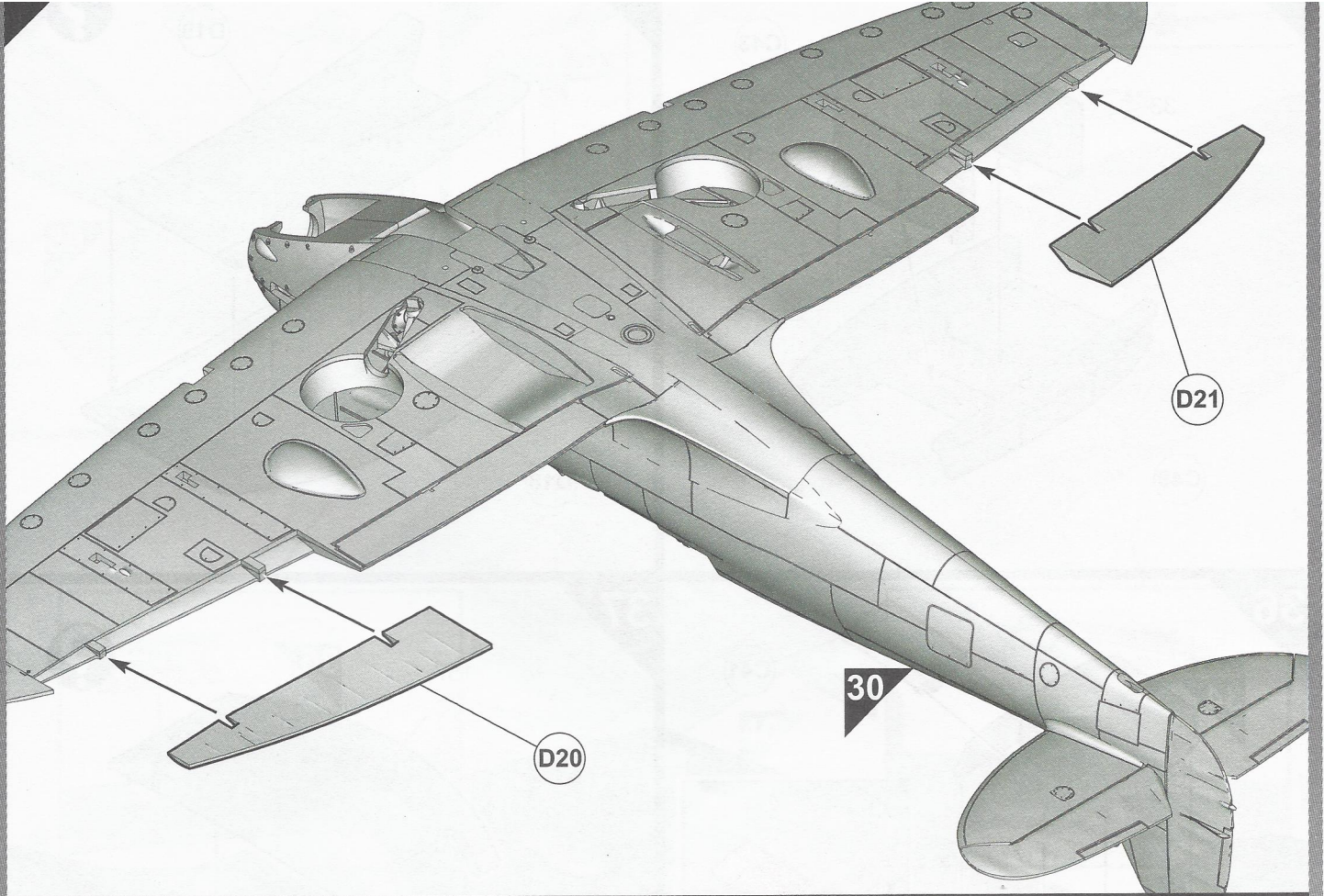

34

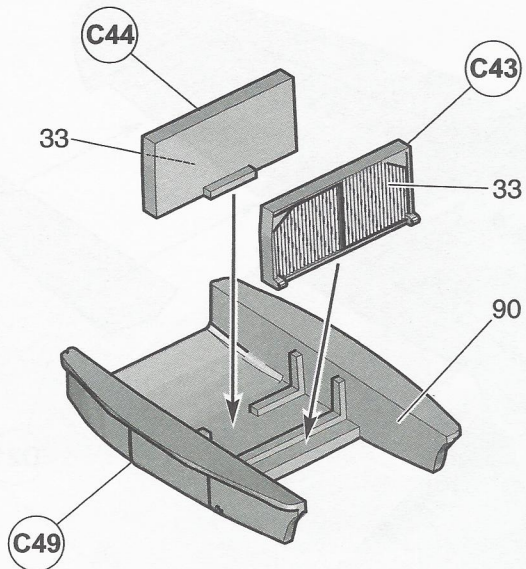

35

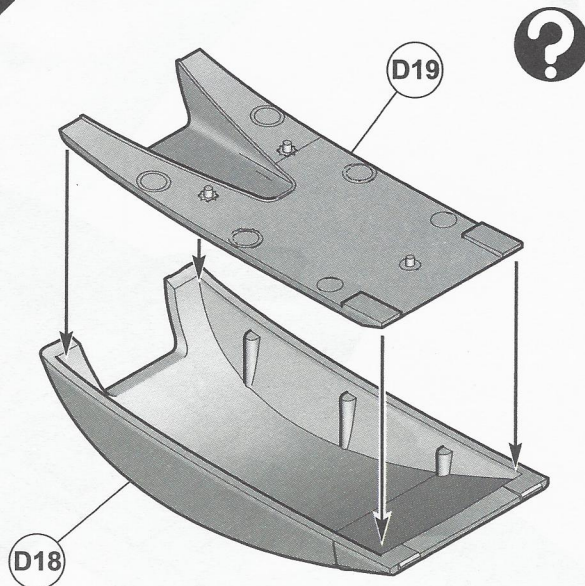

36

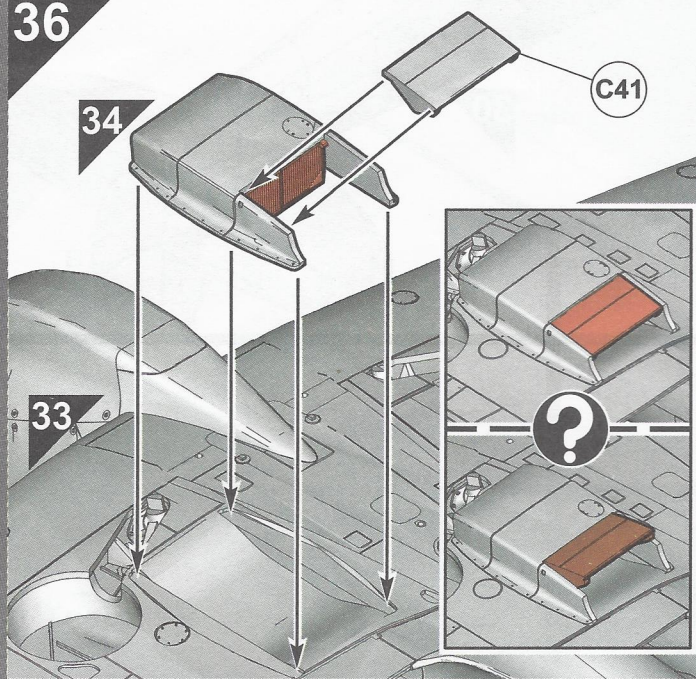

37

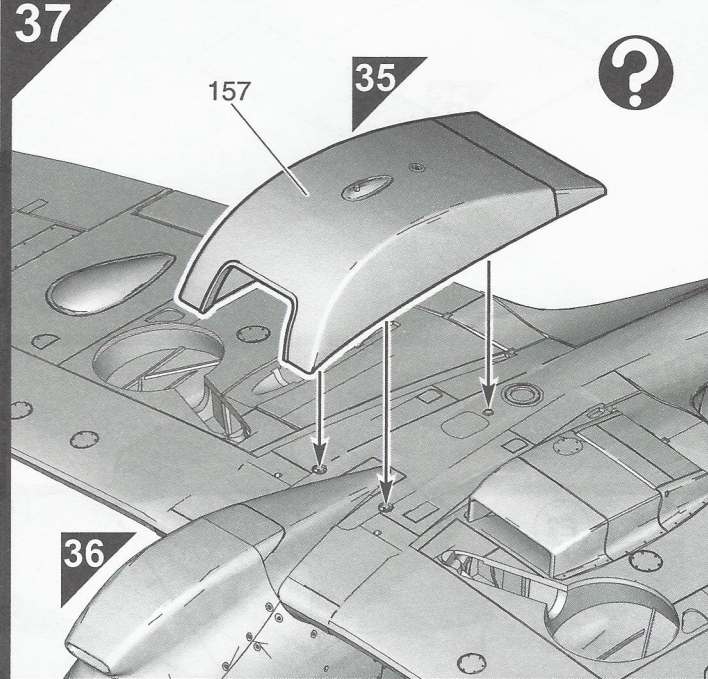

38

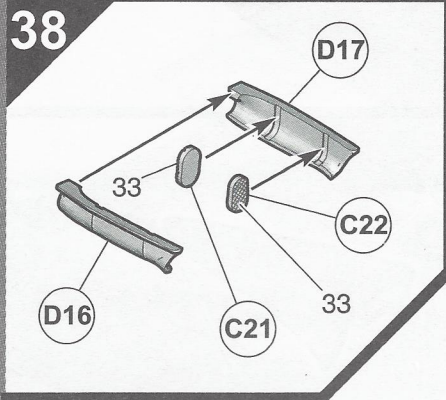

39

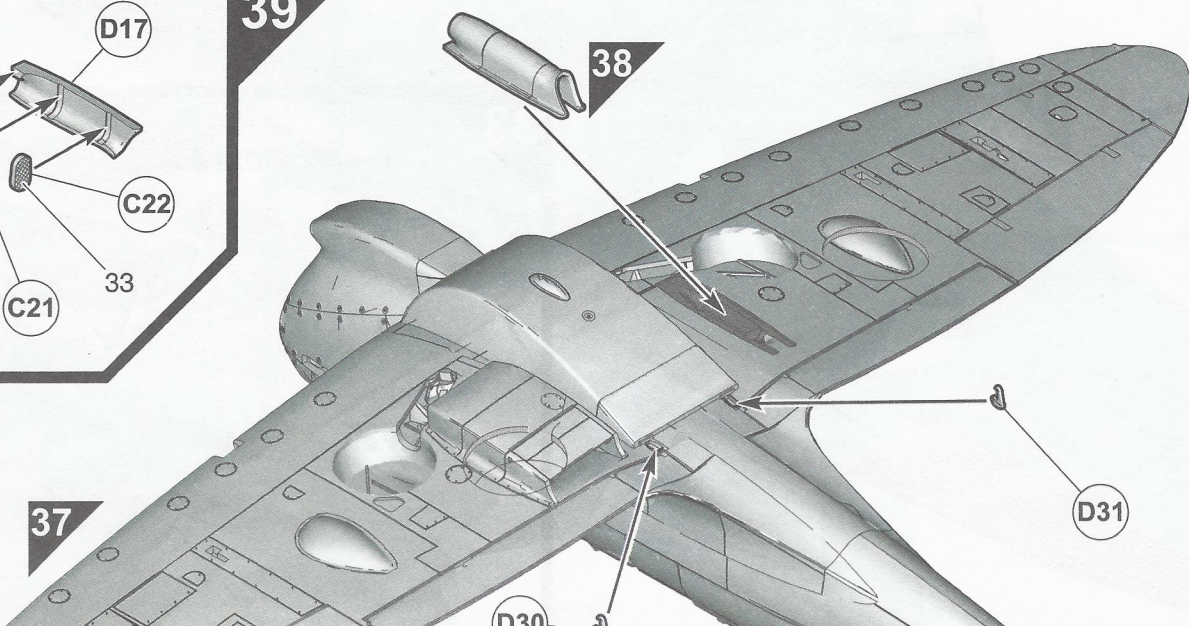

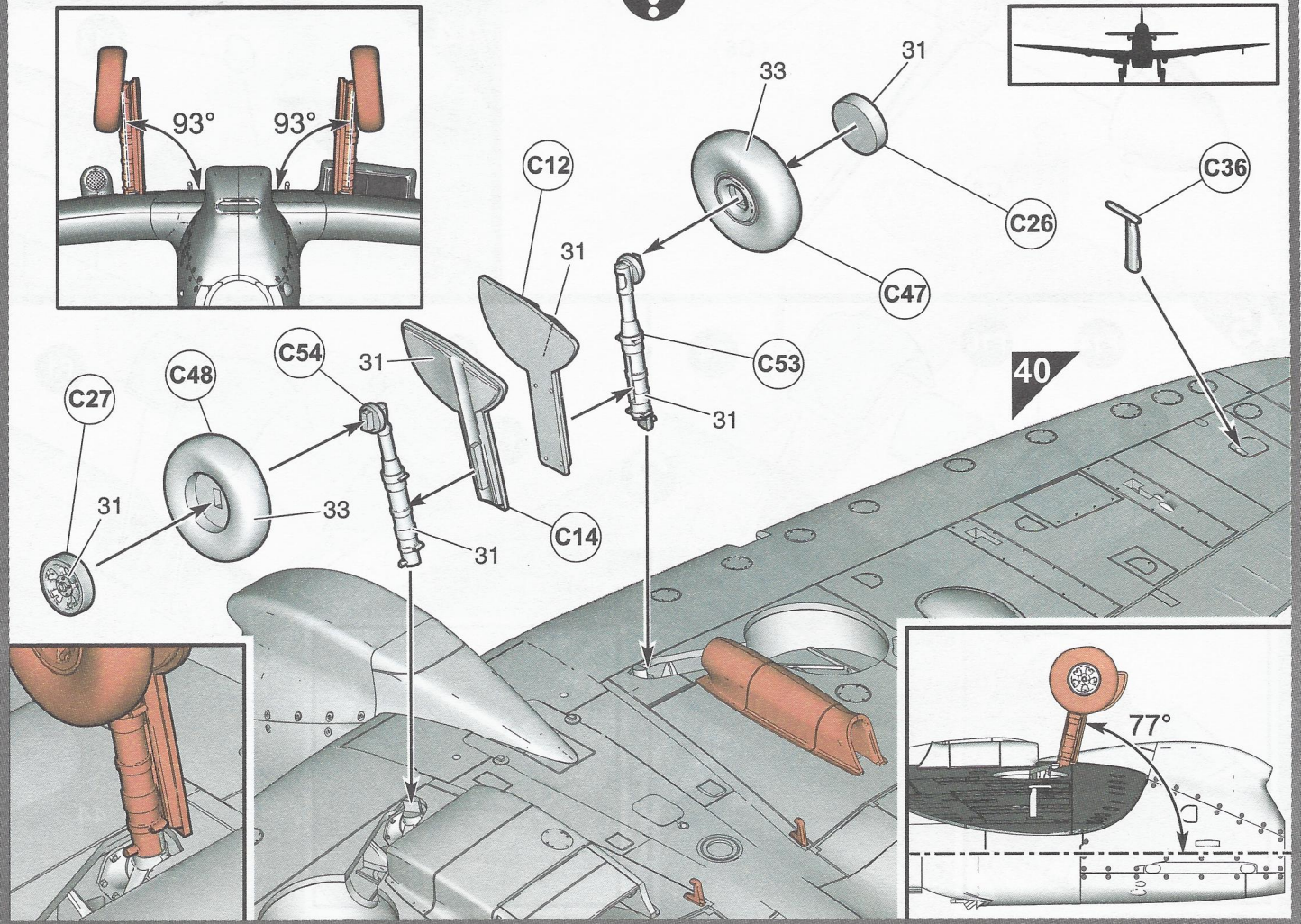
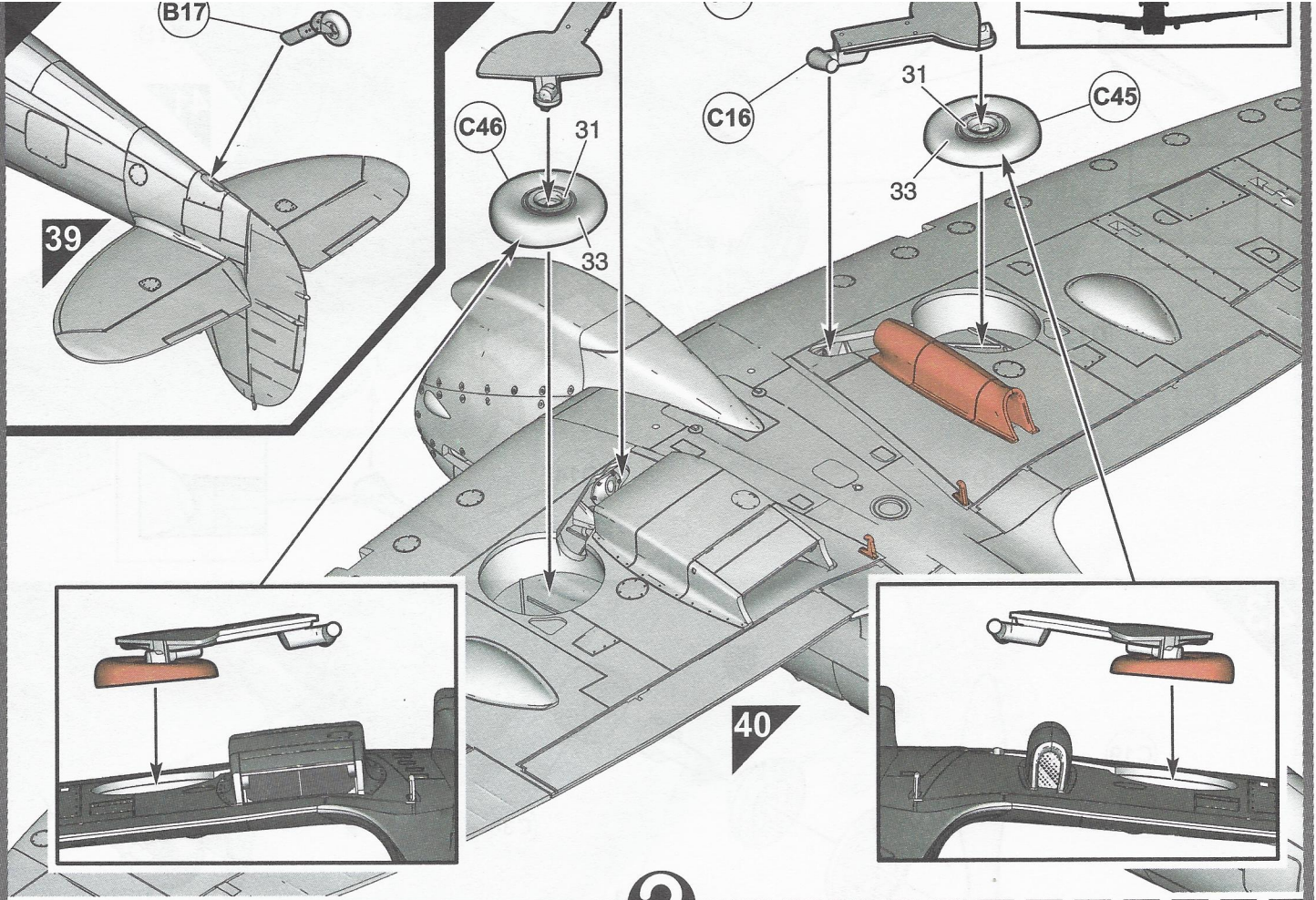

42

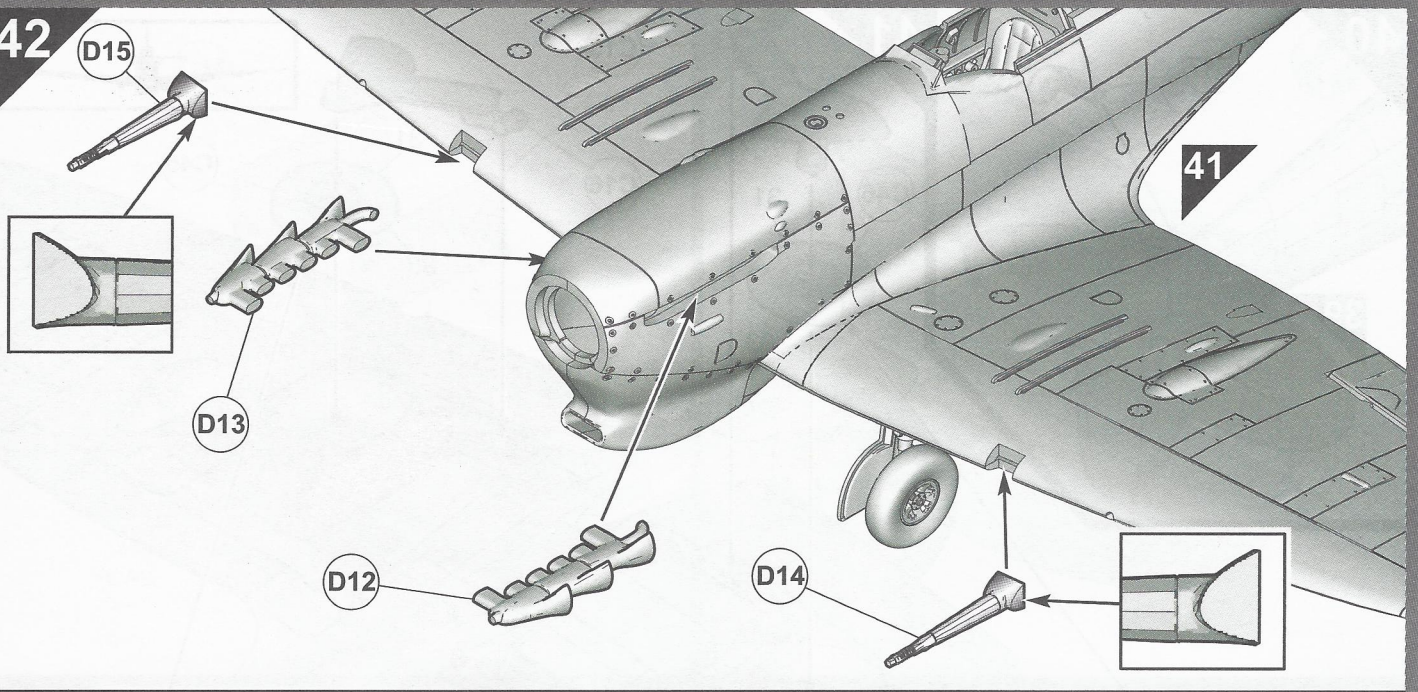

43

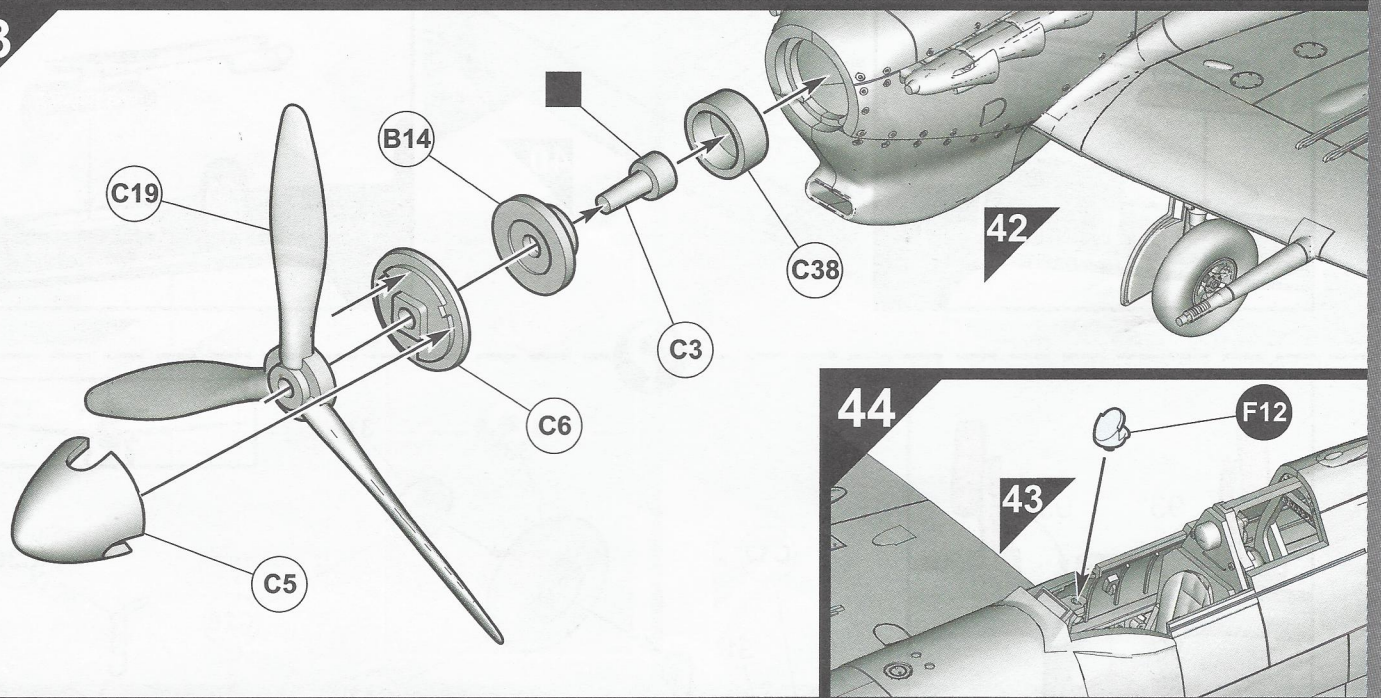

45

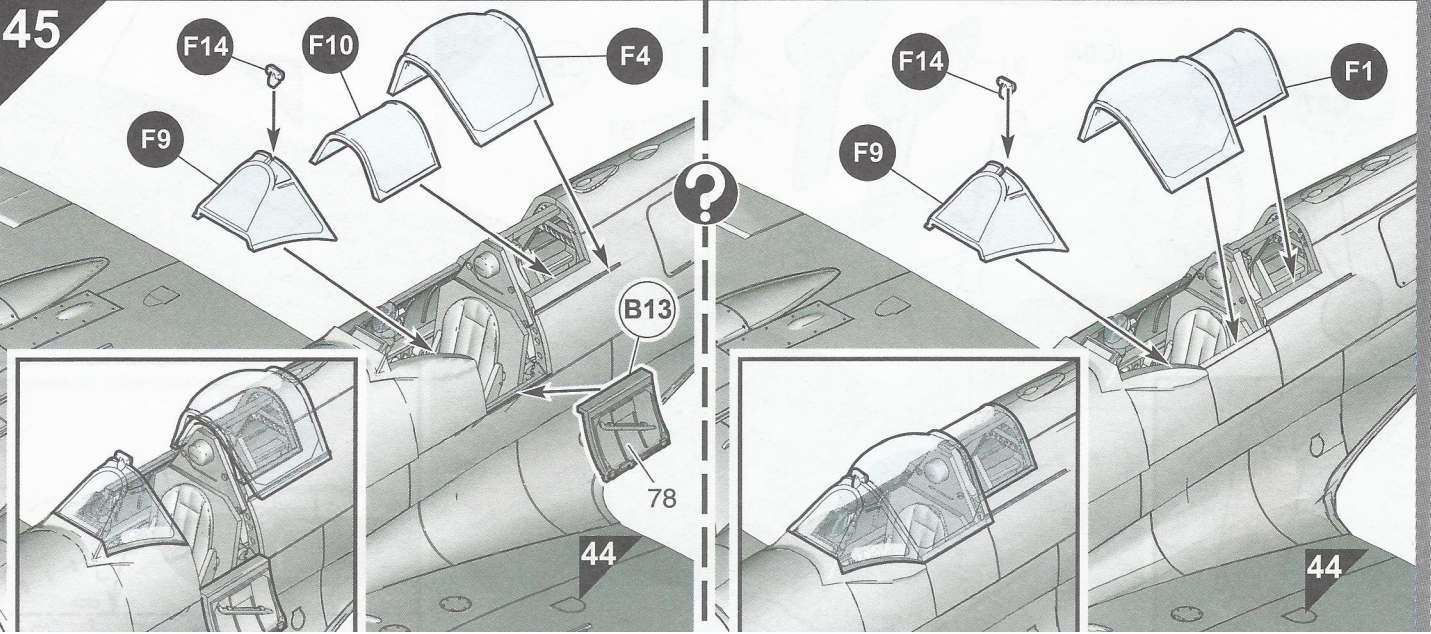

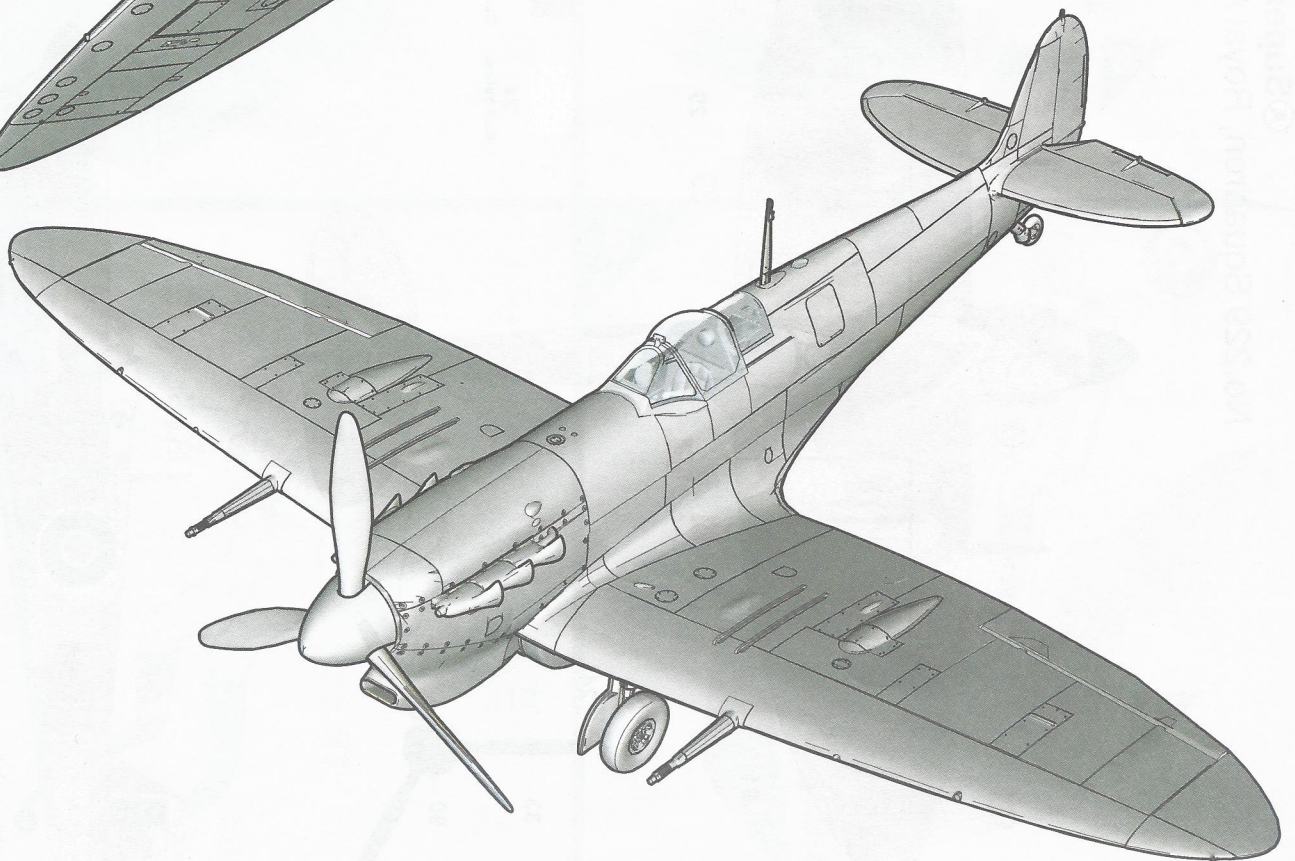
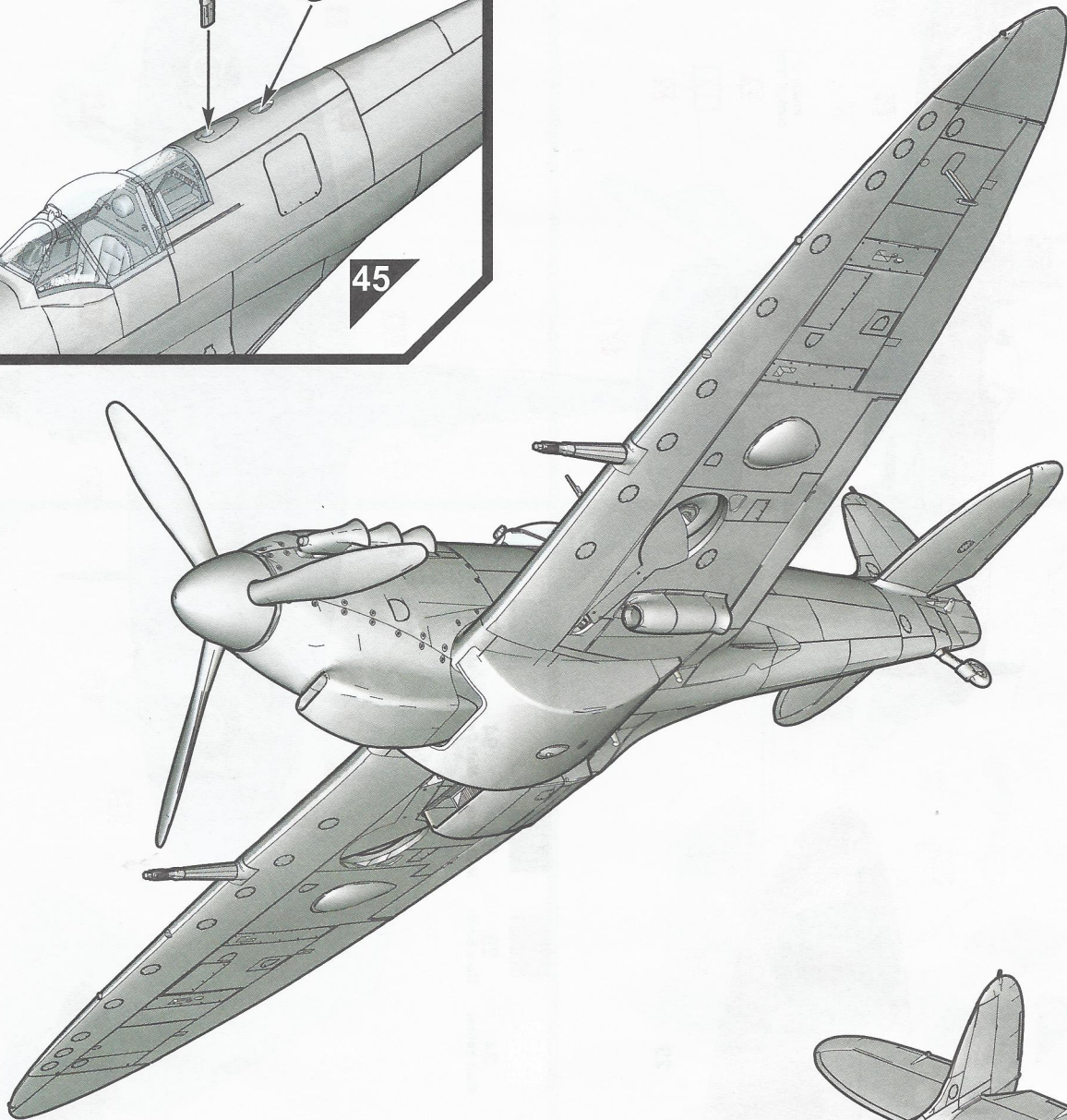
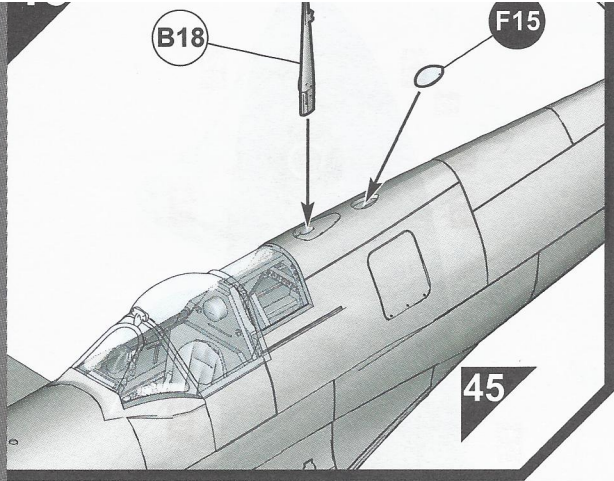

A Supermarine Spitfire Mk.Vb
 No.229 Squadron, Royal Air Force, Qrendi, Malta, December 1942.

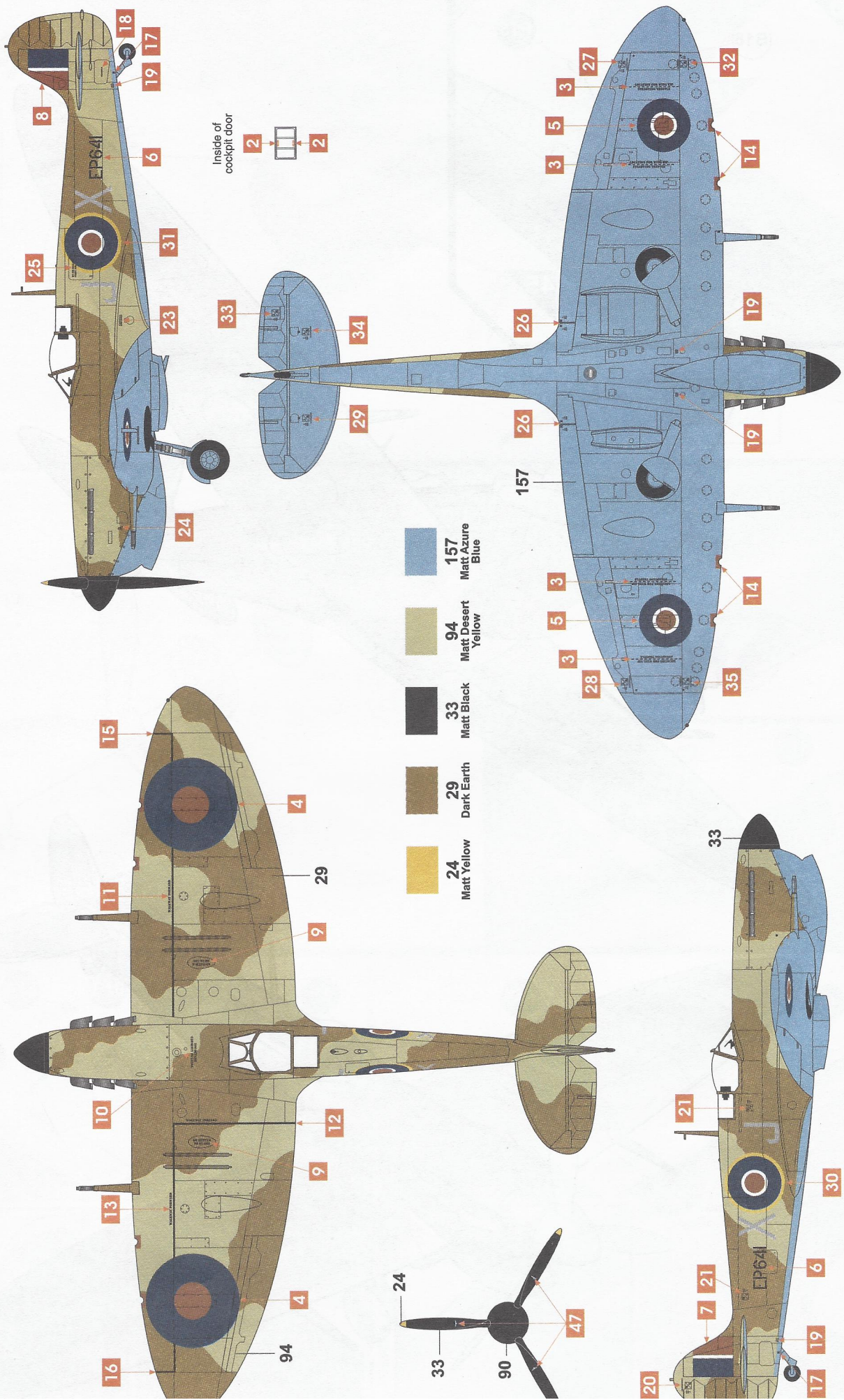

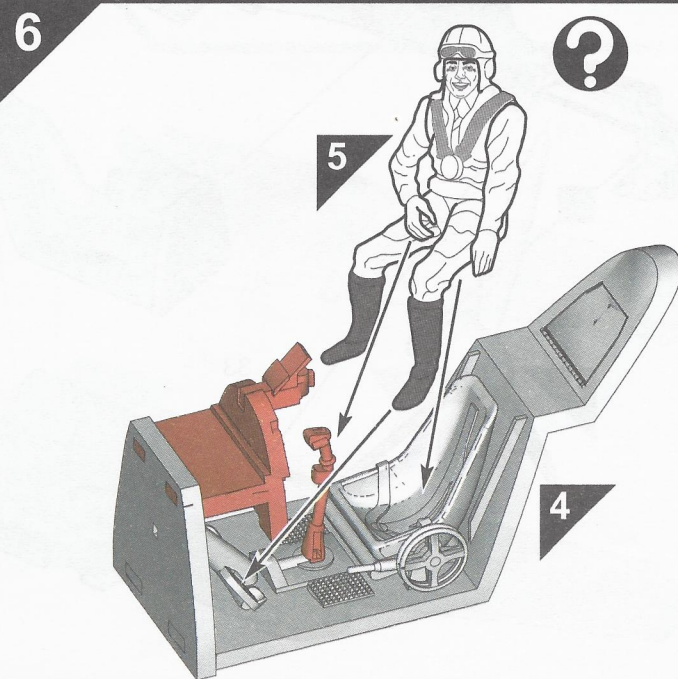
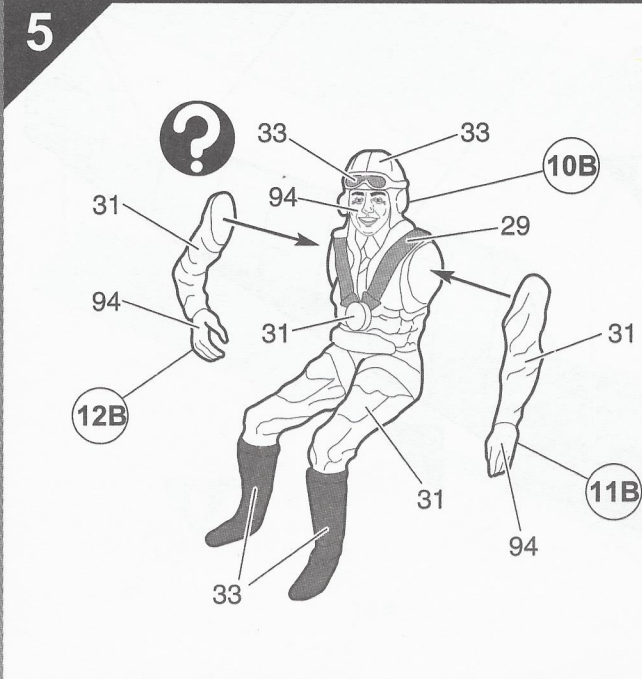
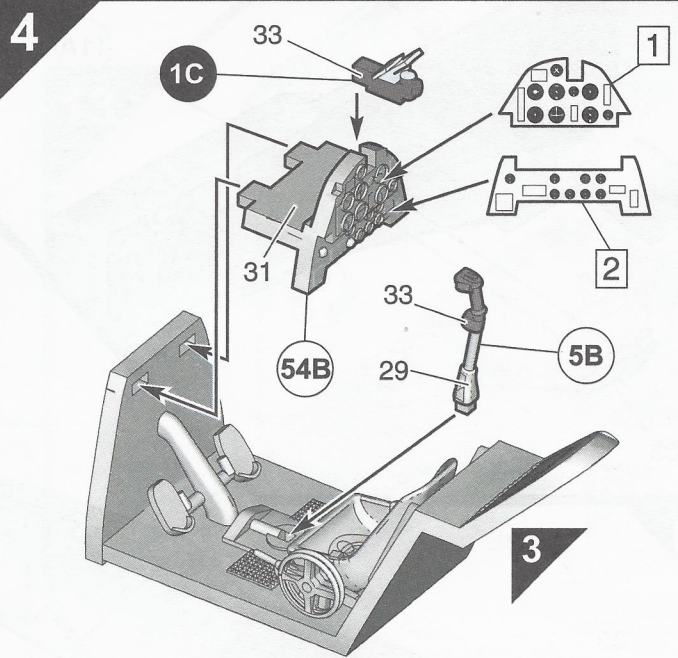
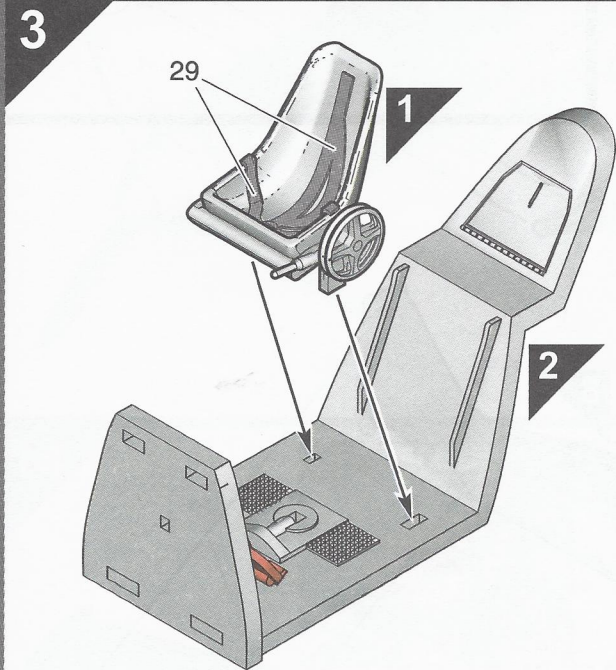
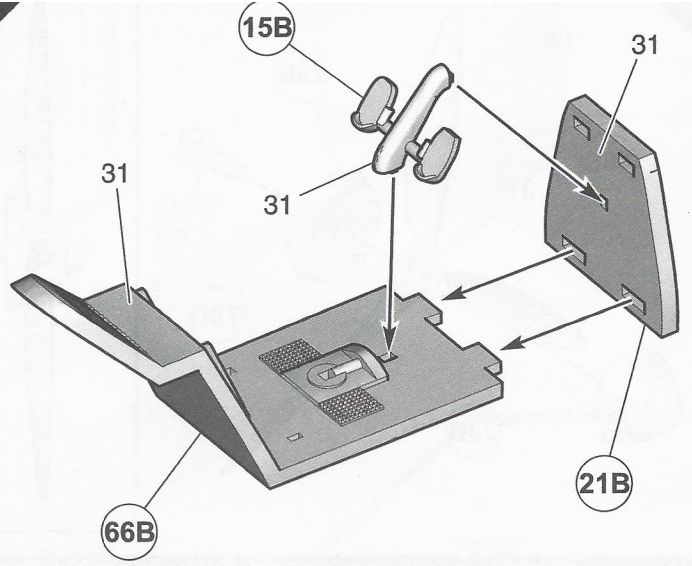
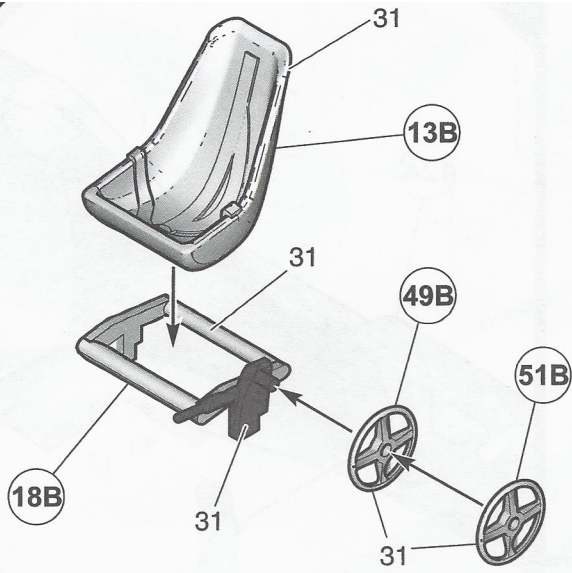

7

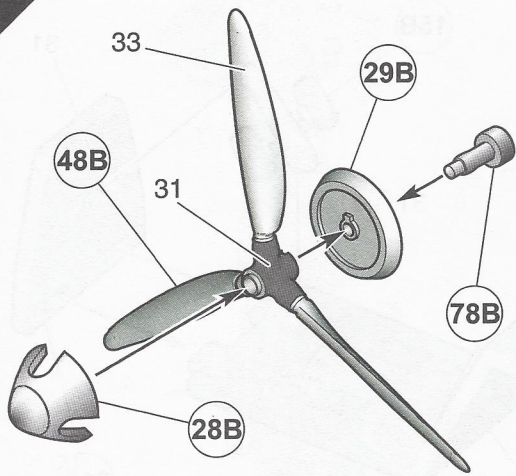

8

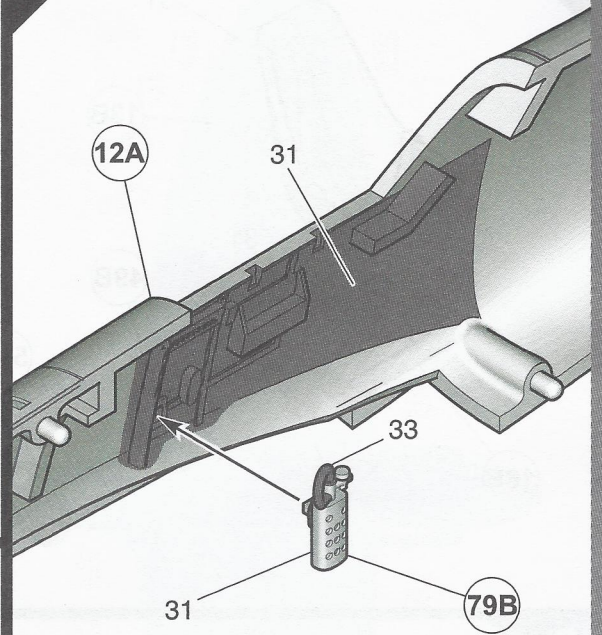

9

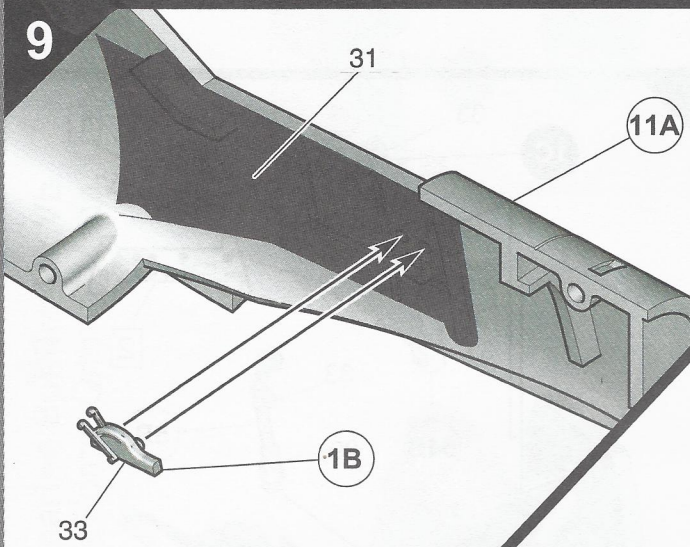

8

10

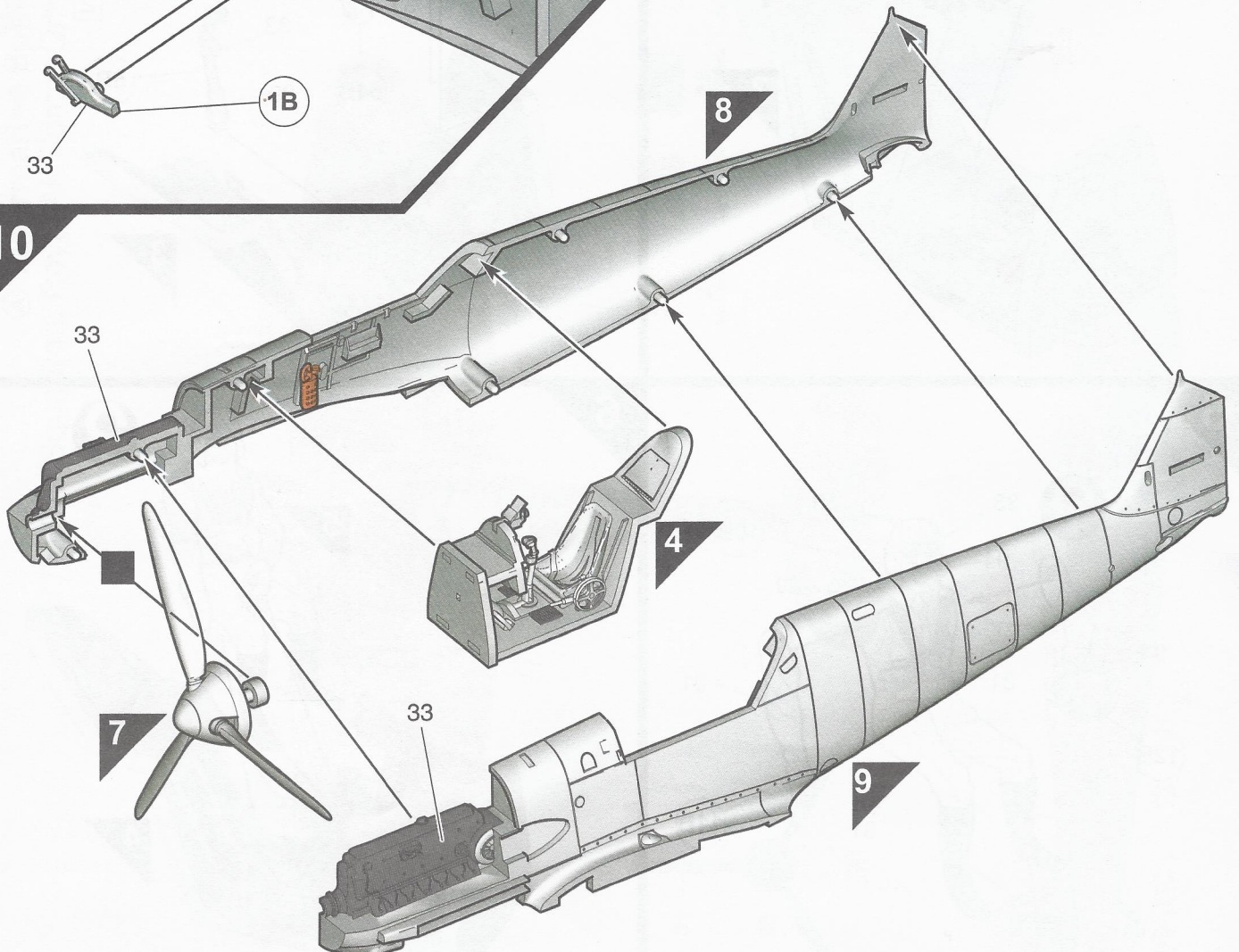

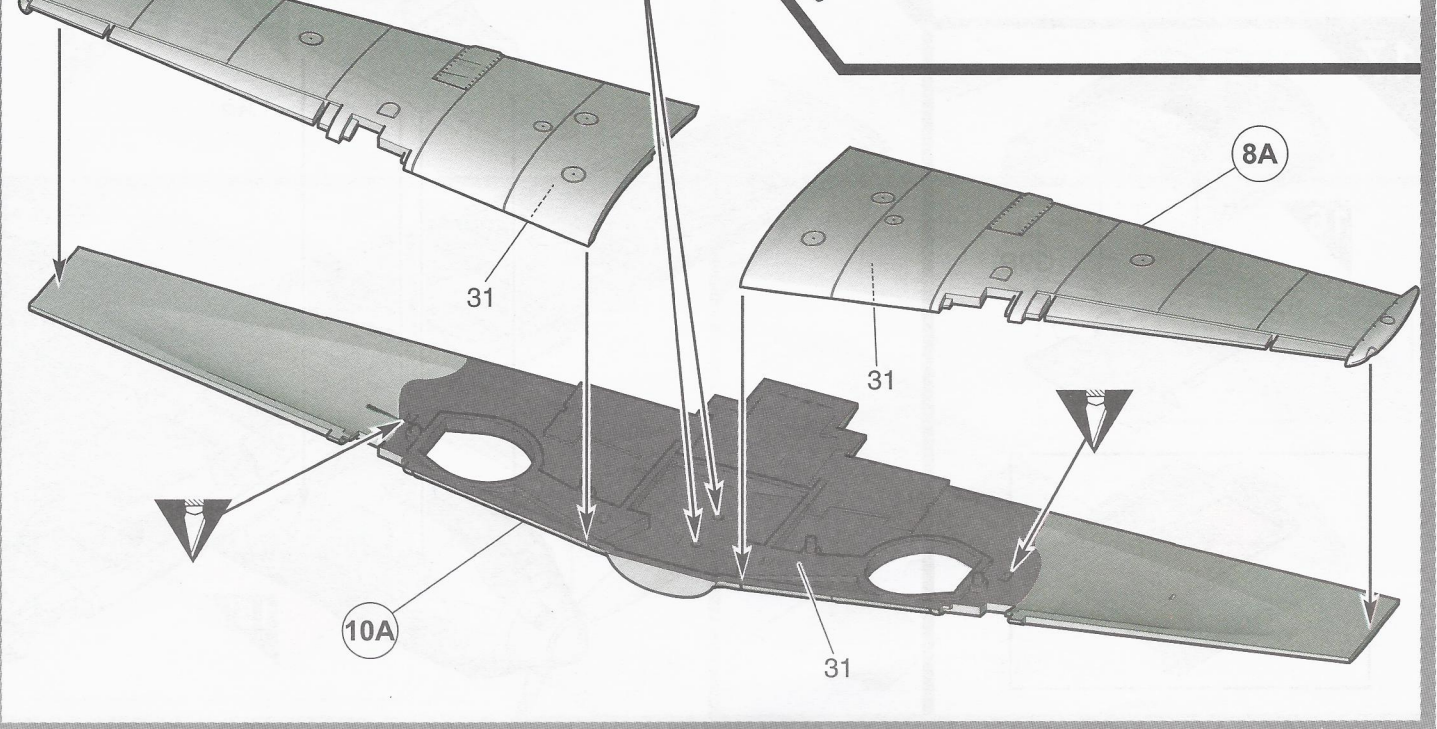
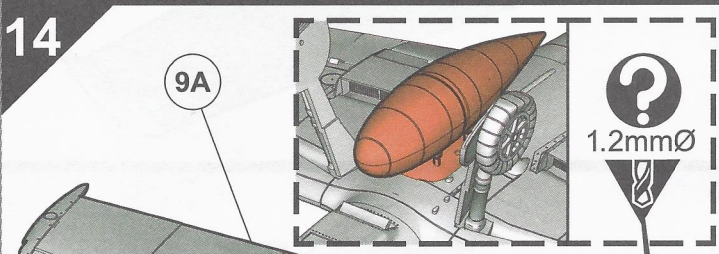
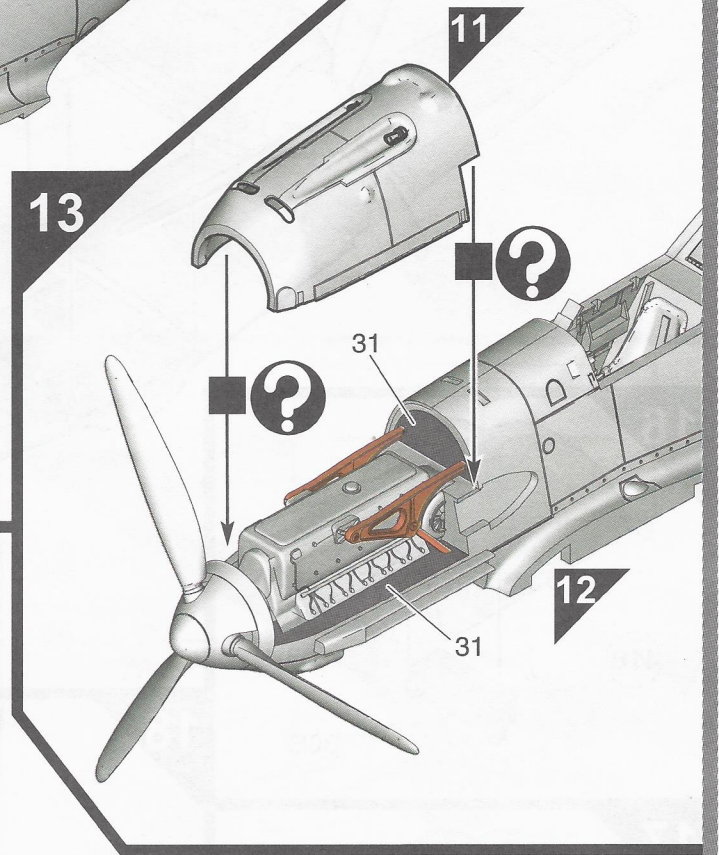
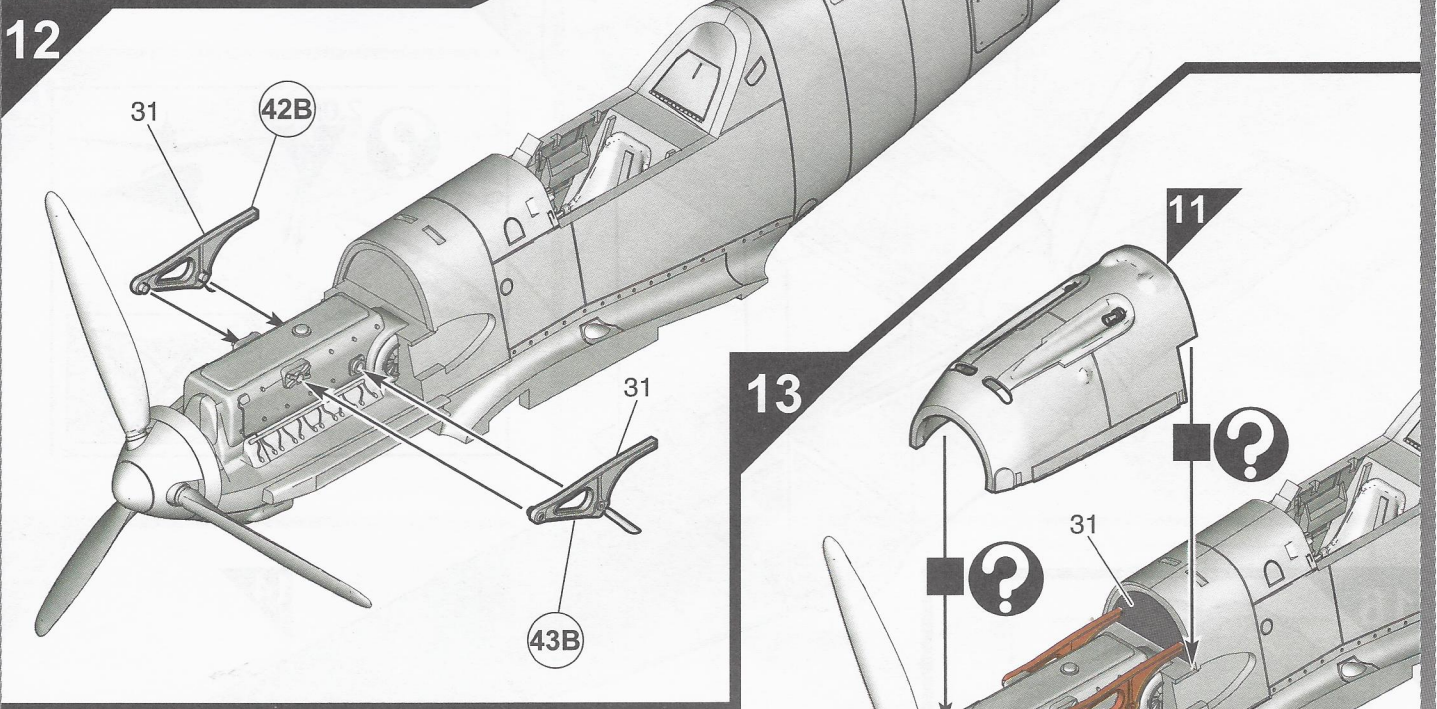
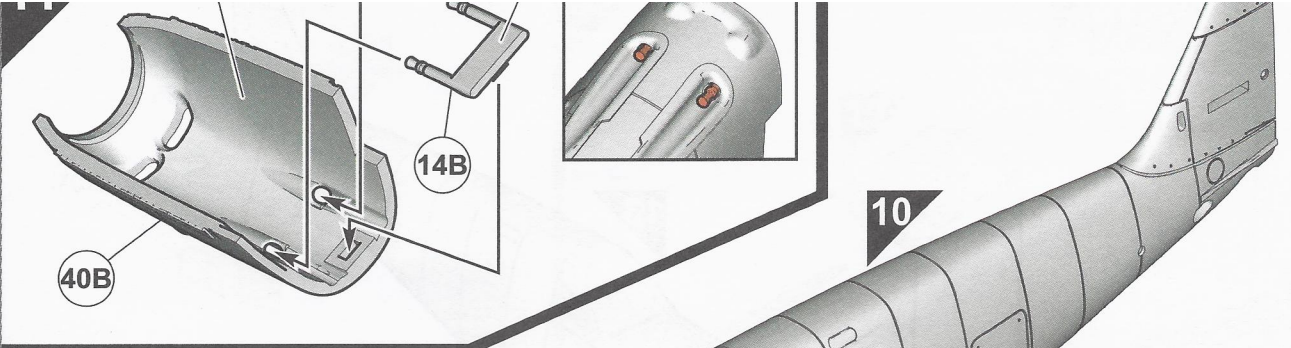

15

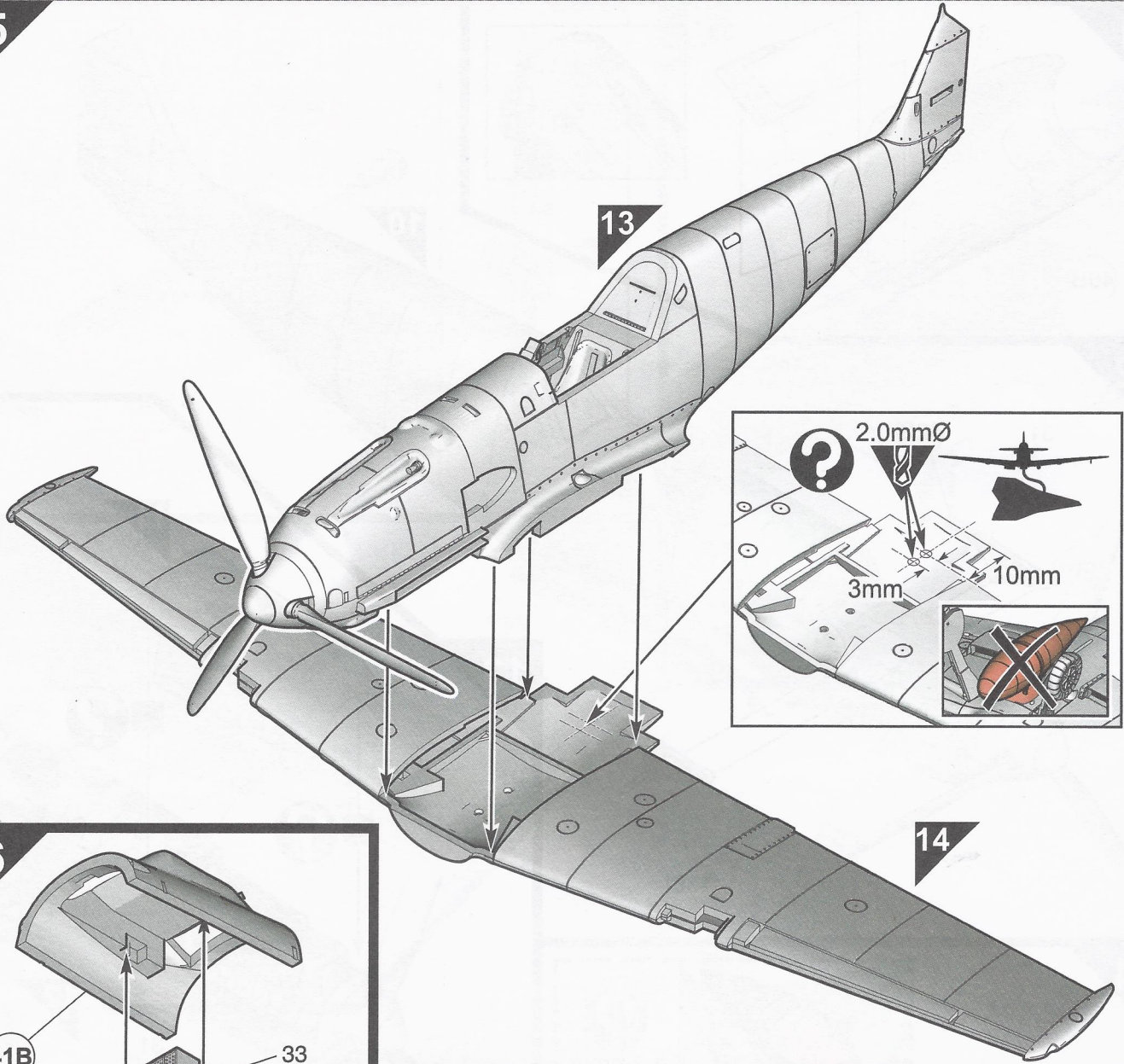

16

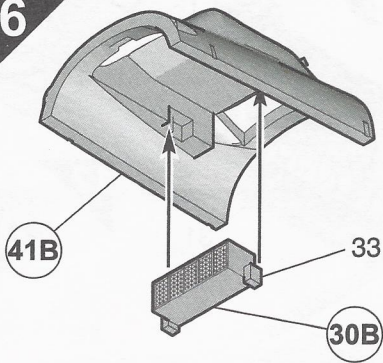

17

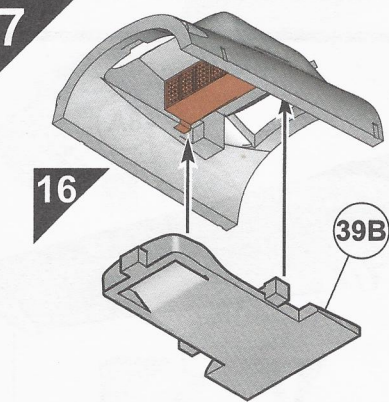

18

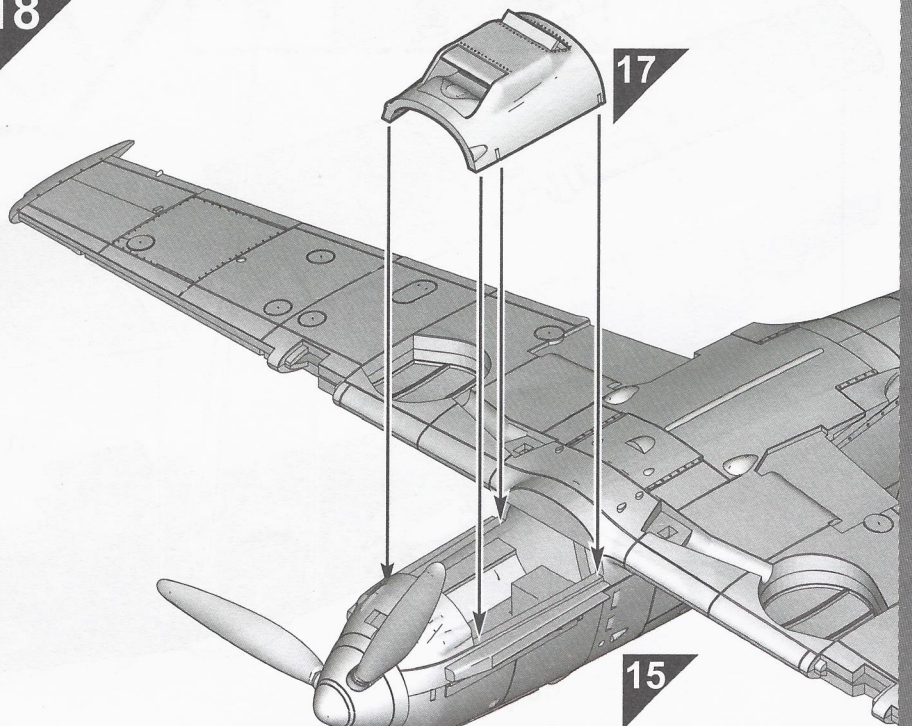

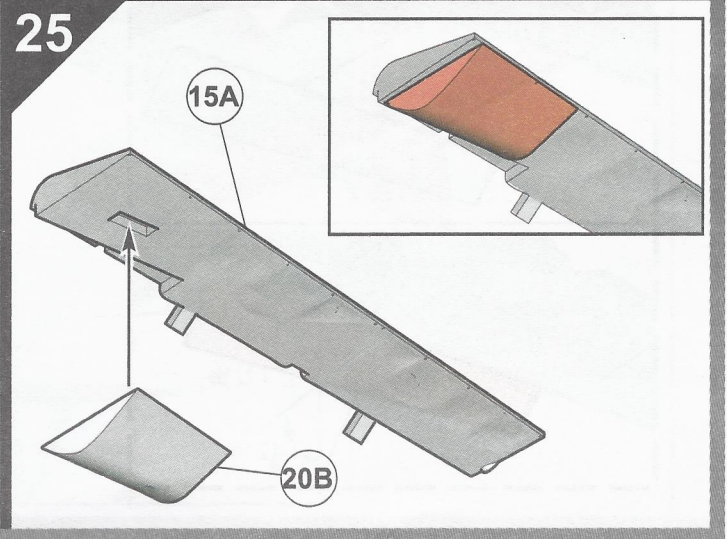
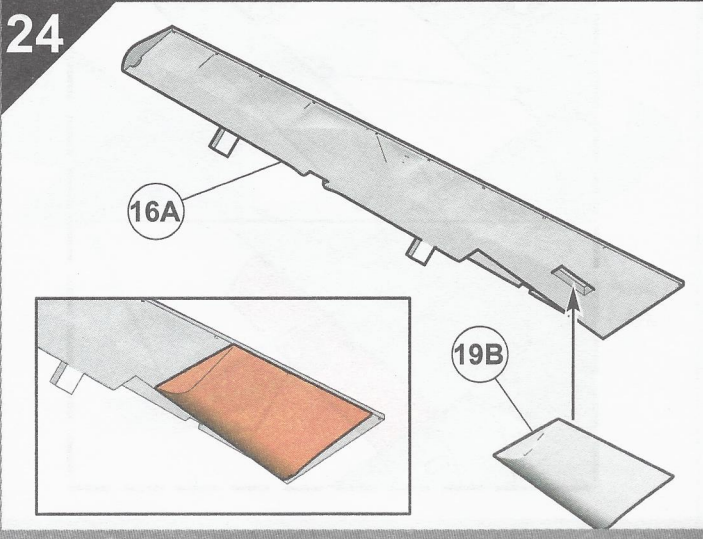
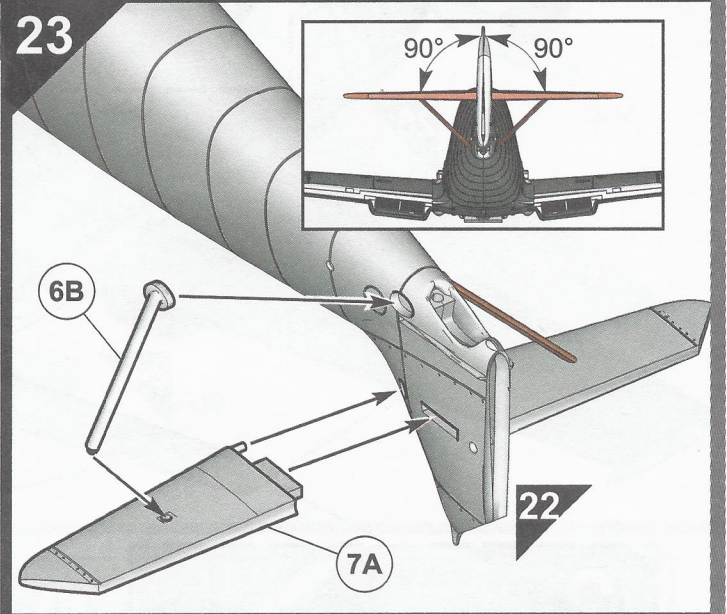
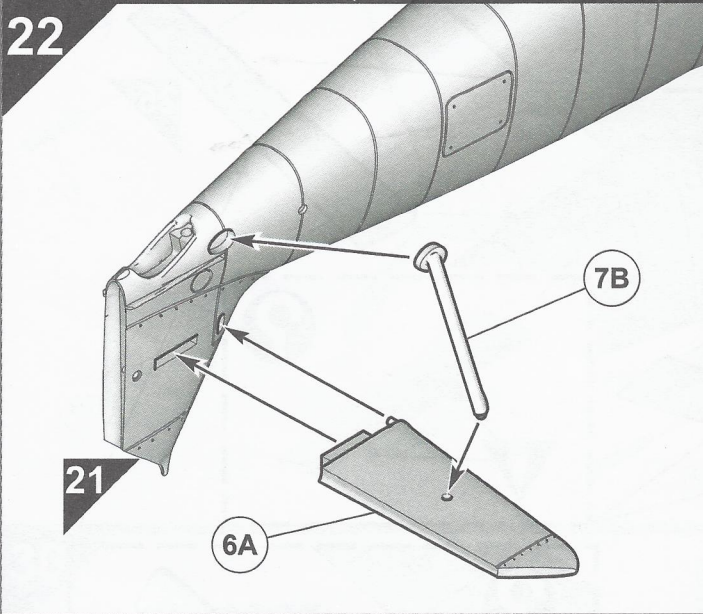
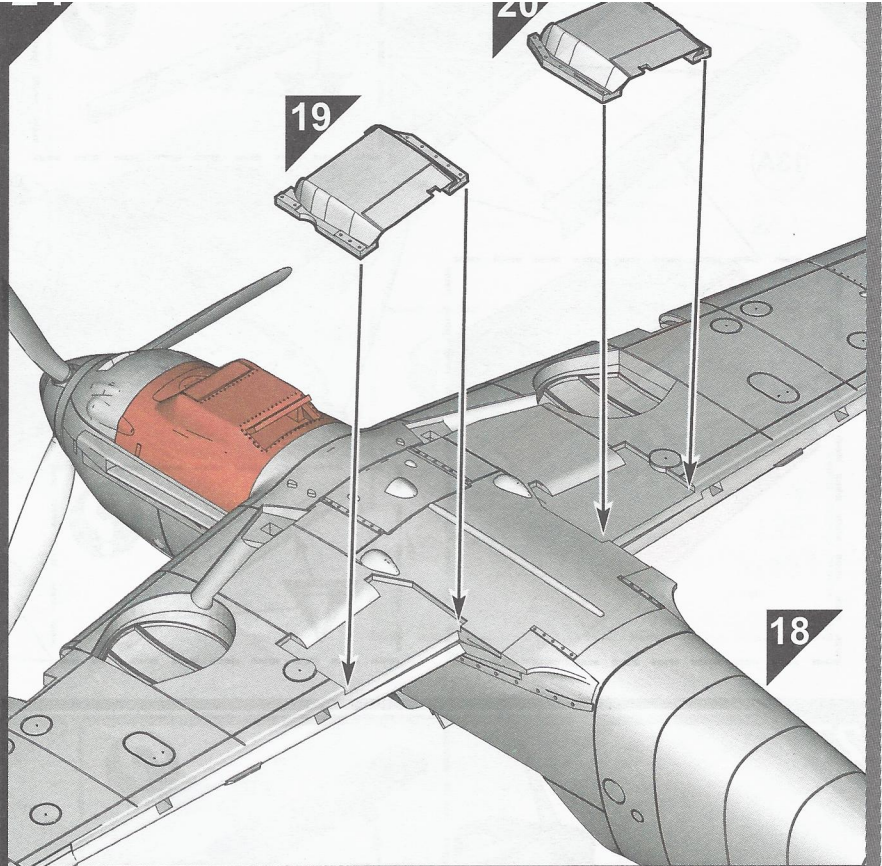
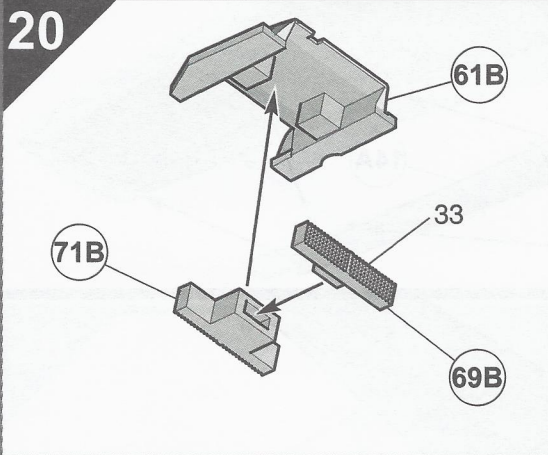
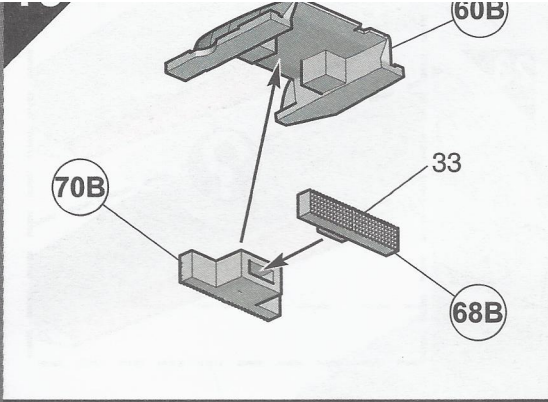

26

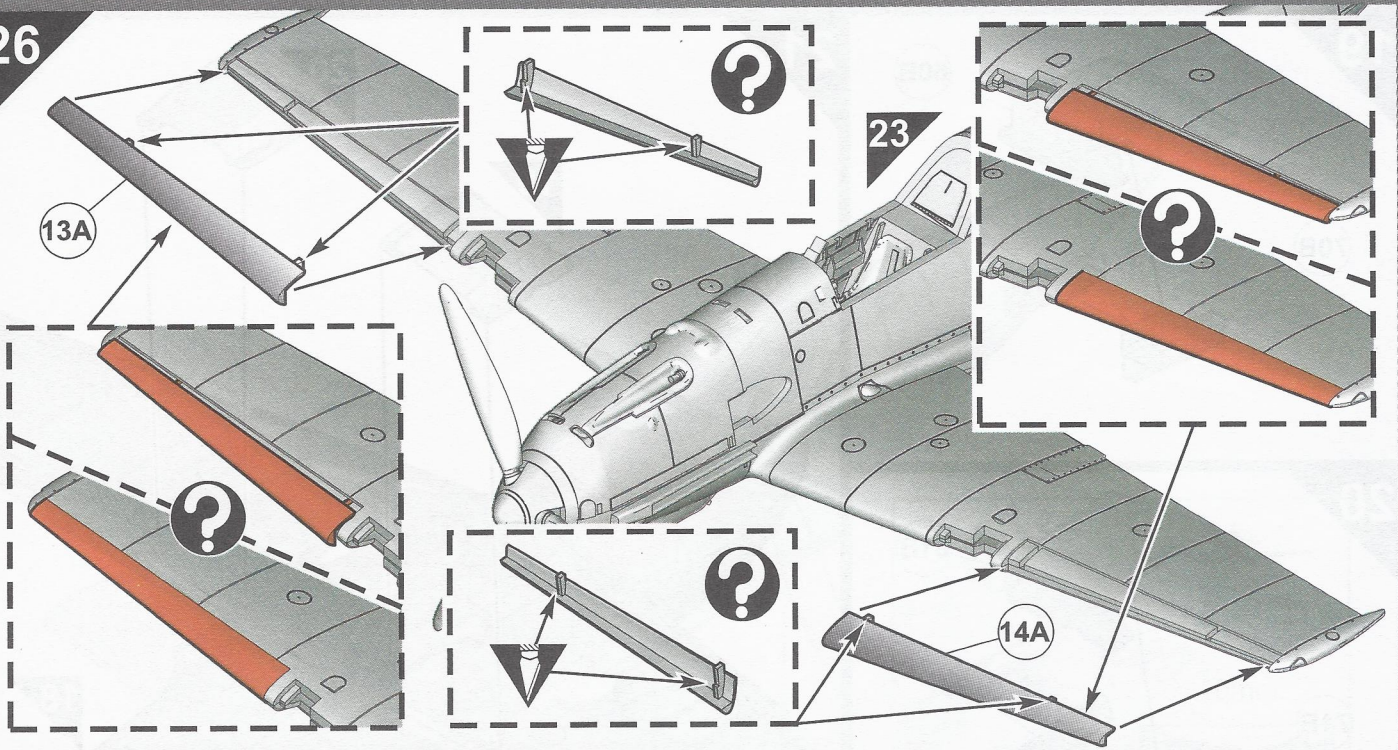

27

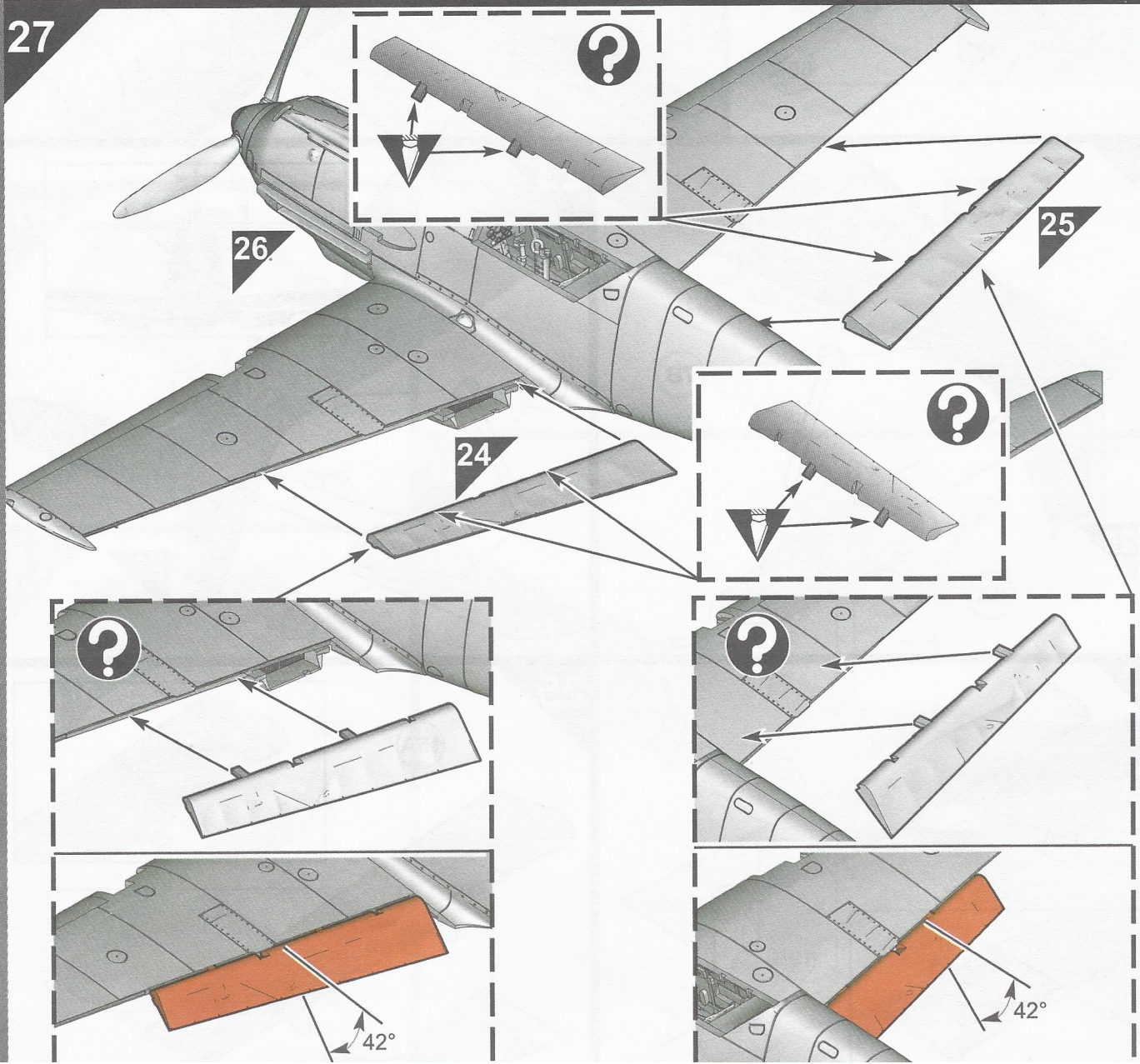

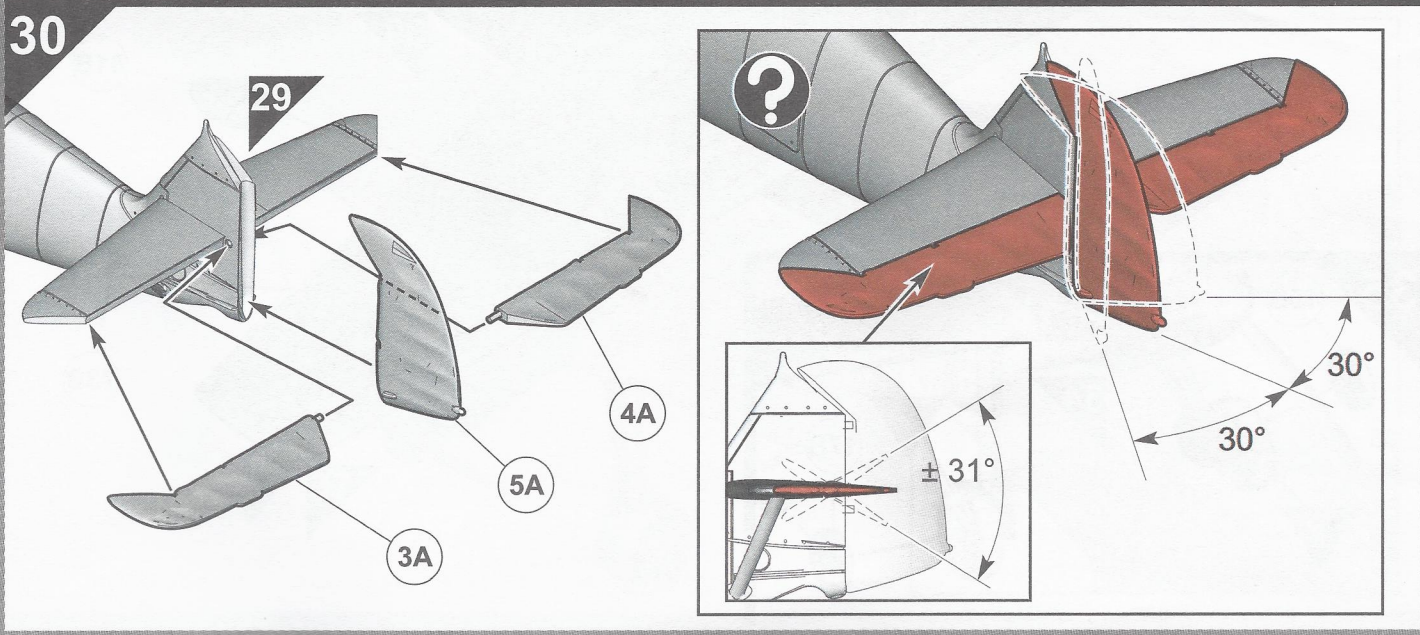
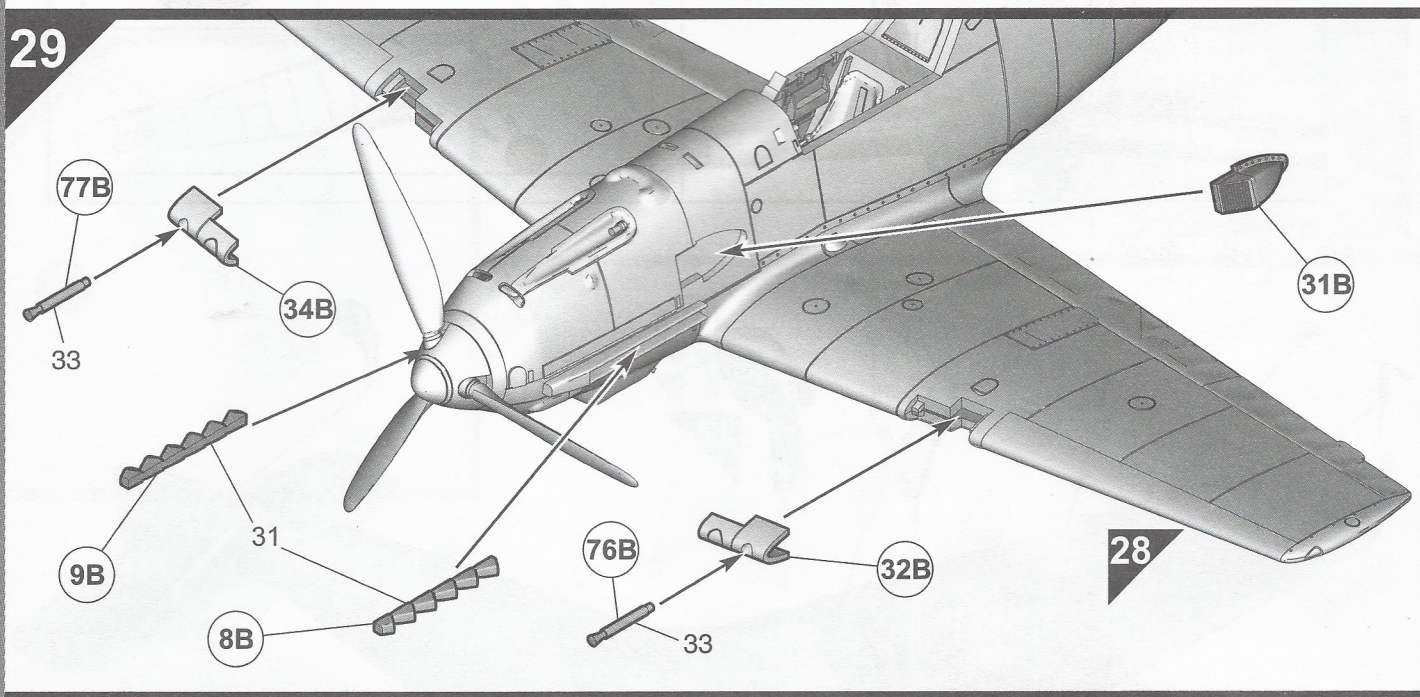
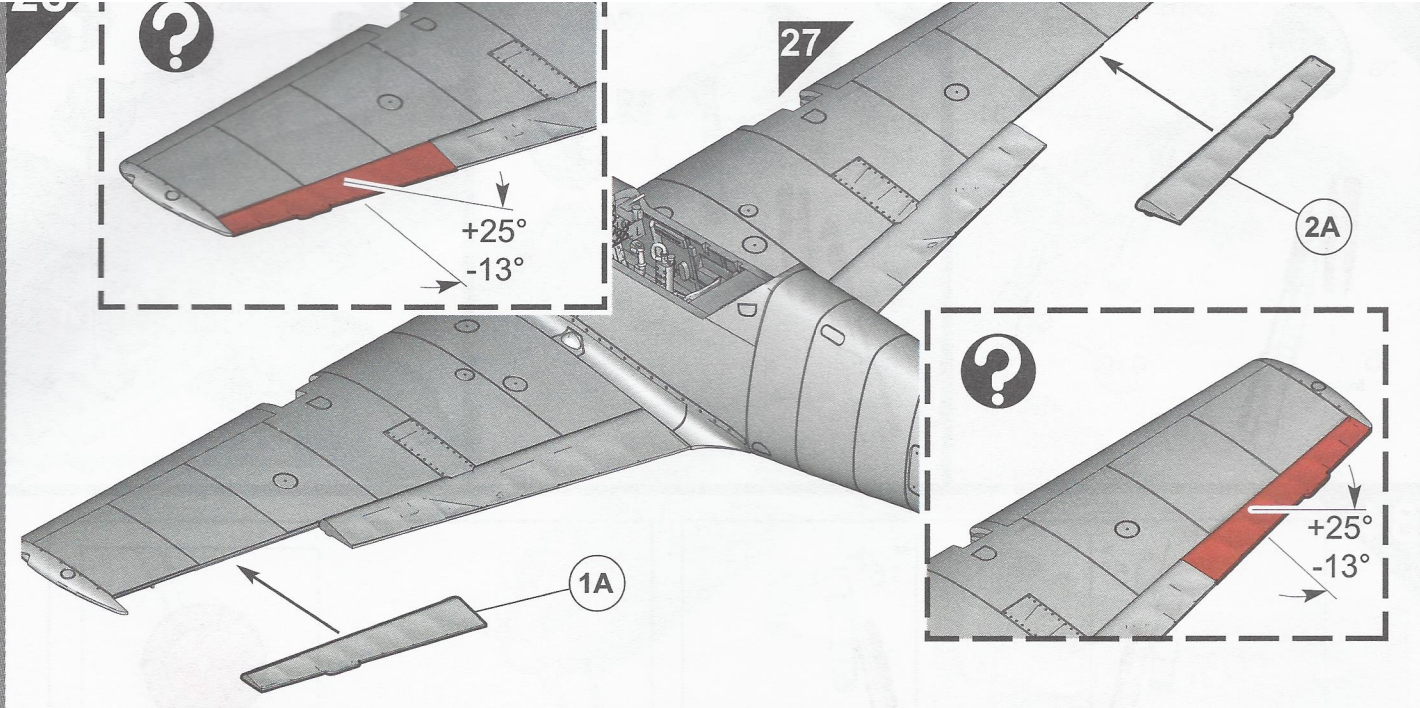

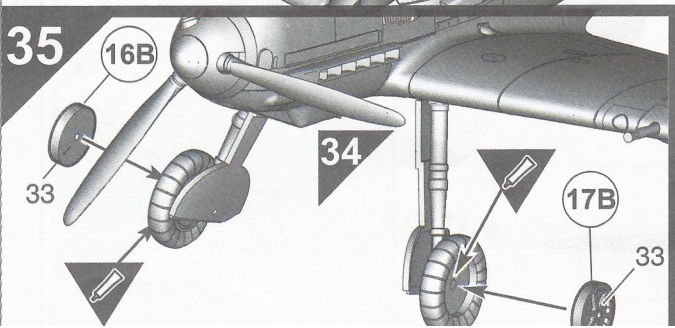
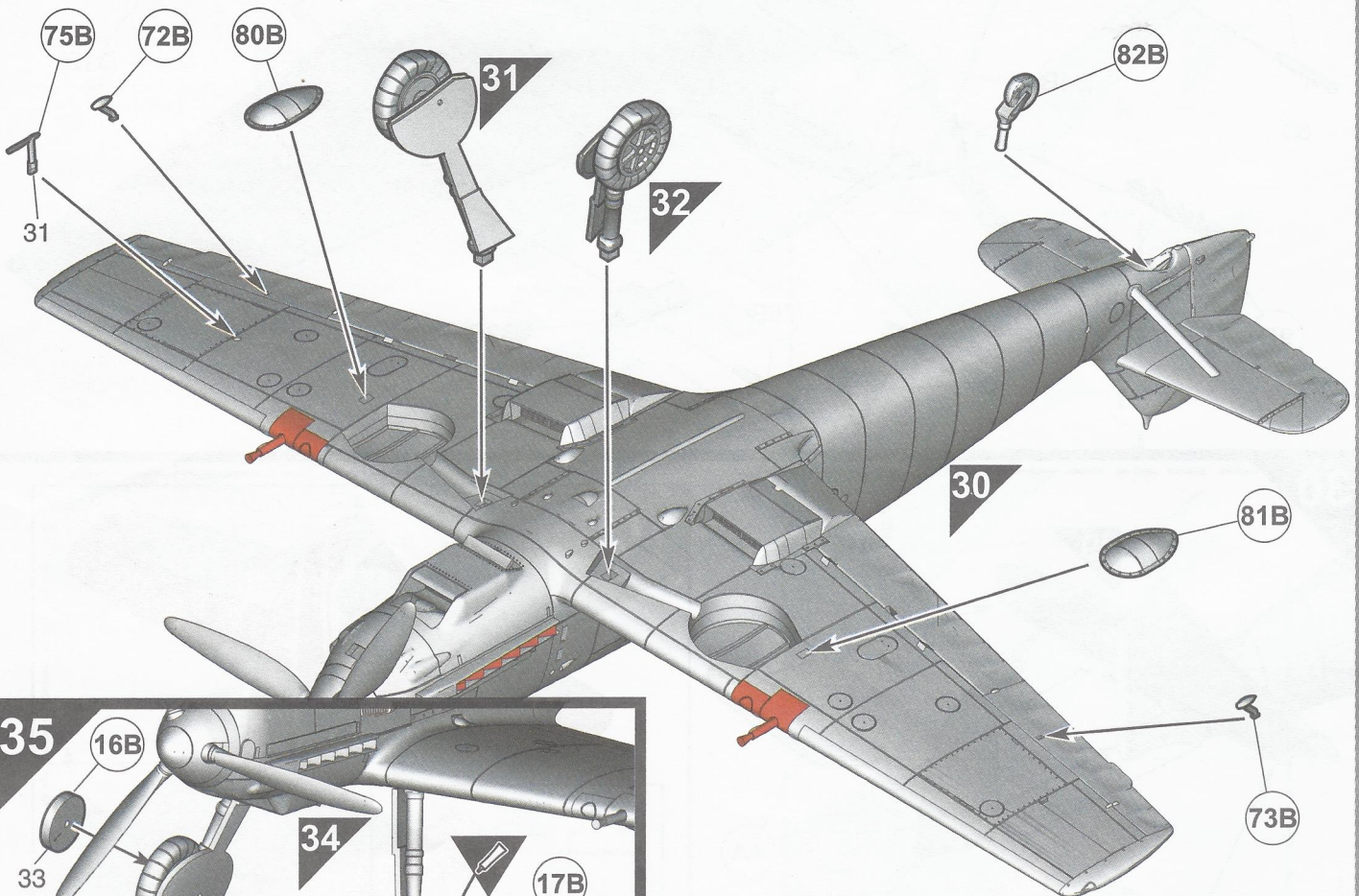
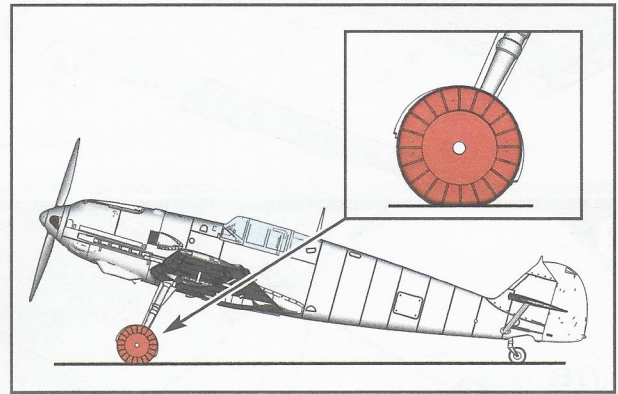
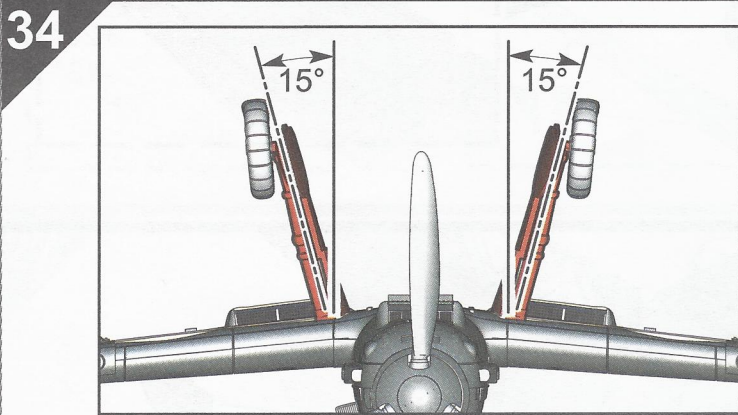
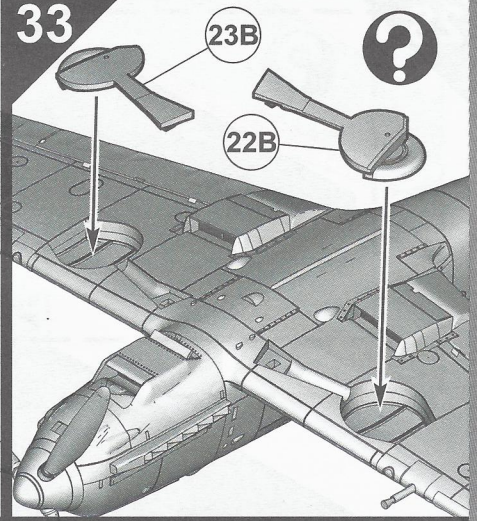
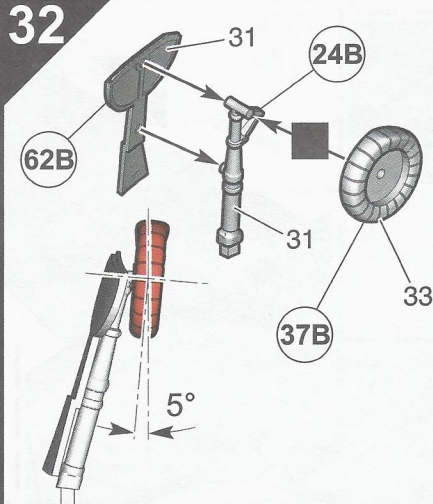
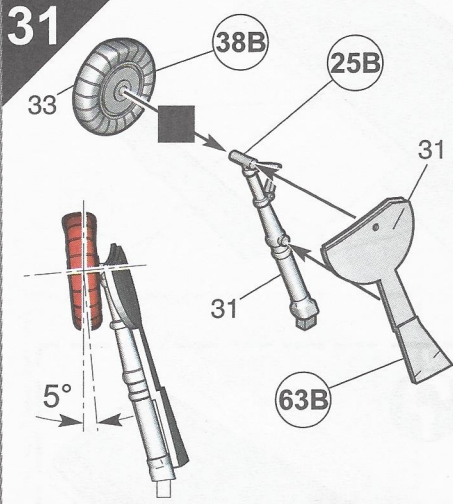

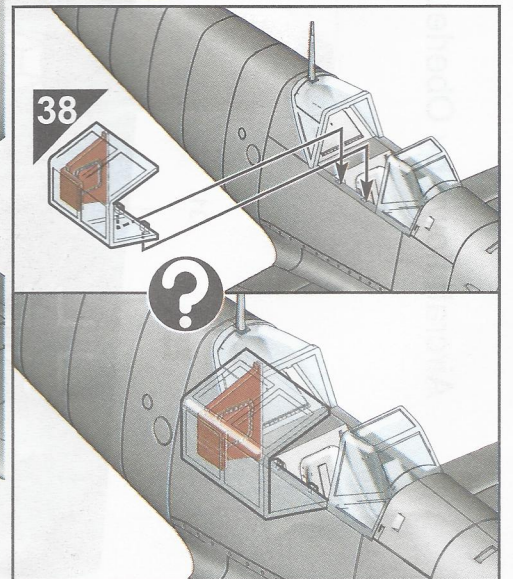
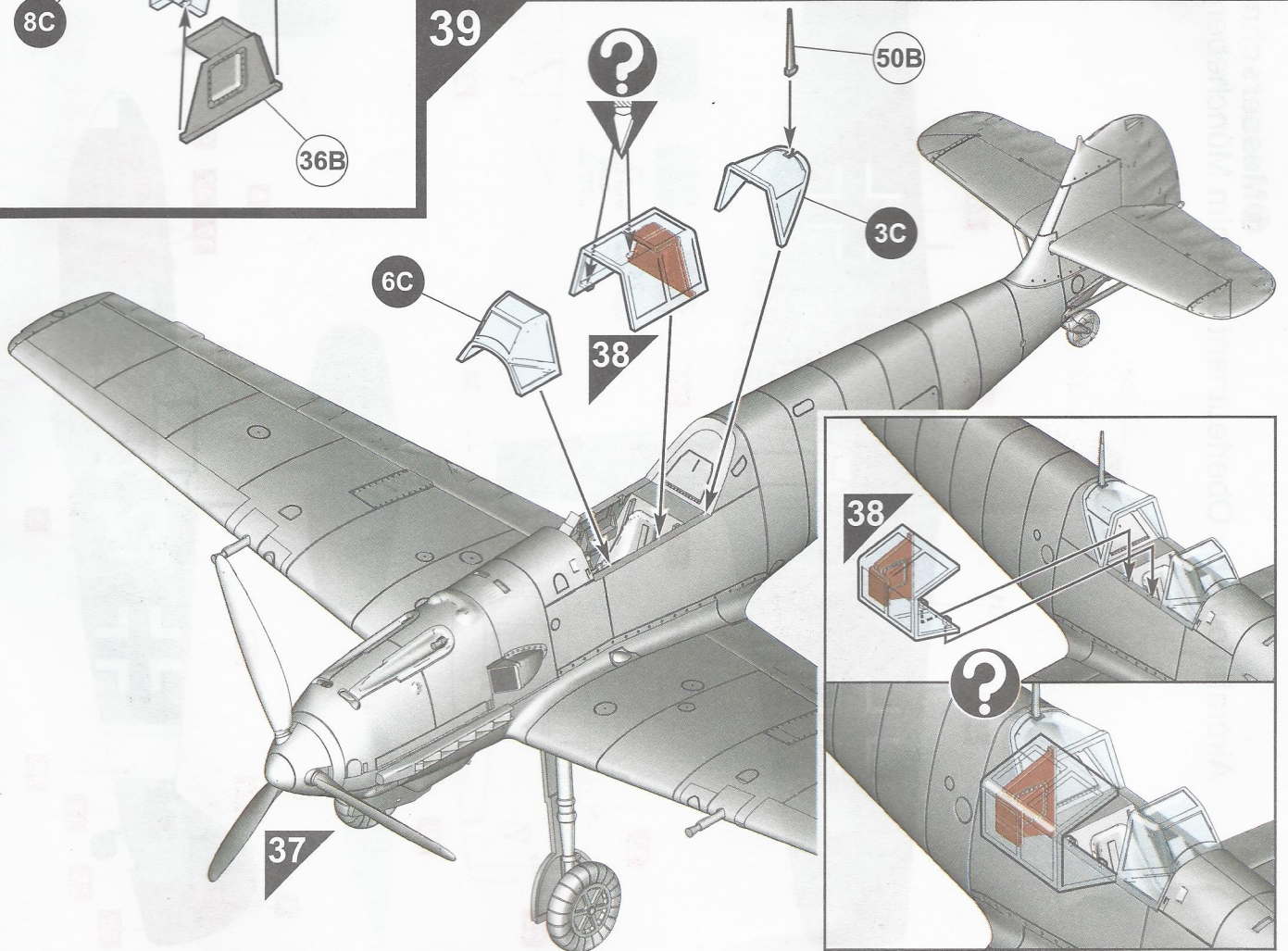
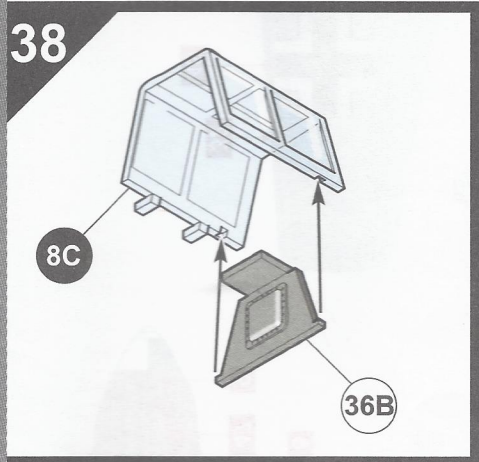
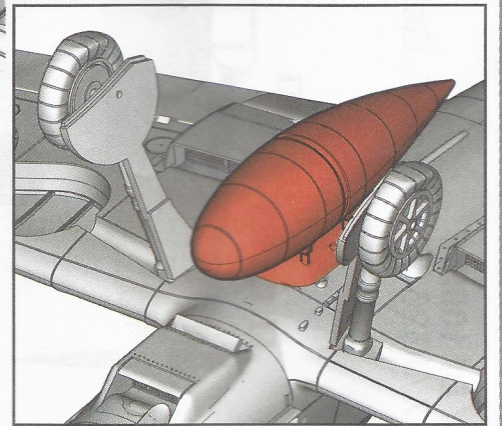
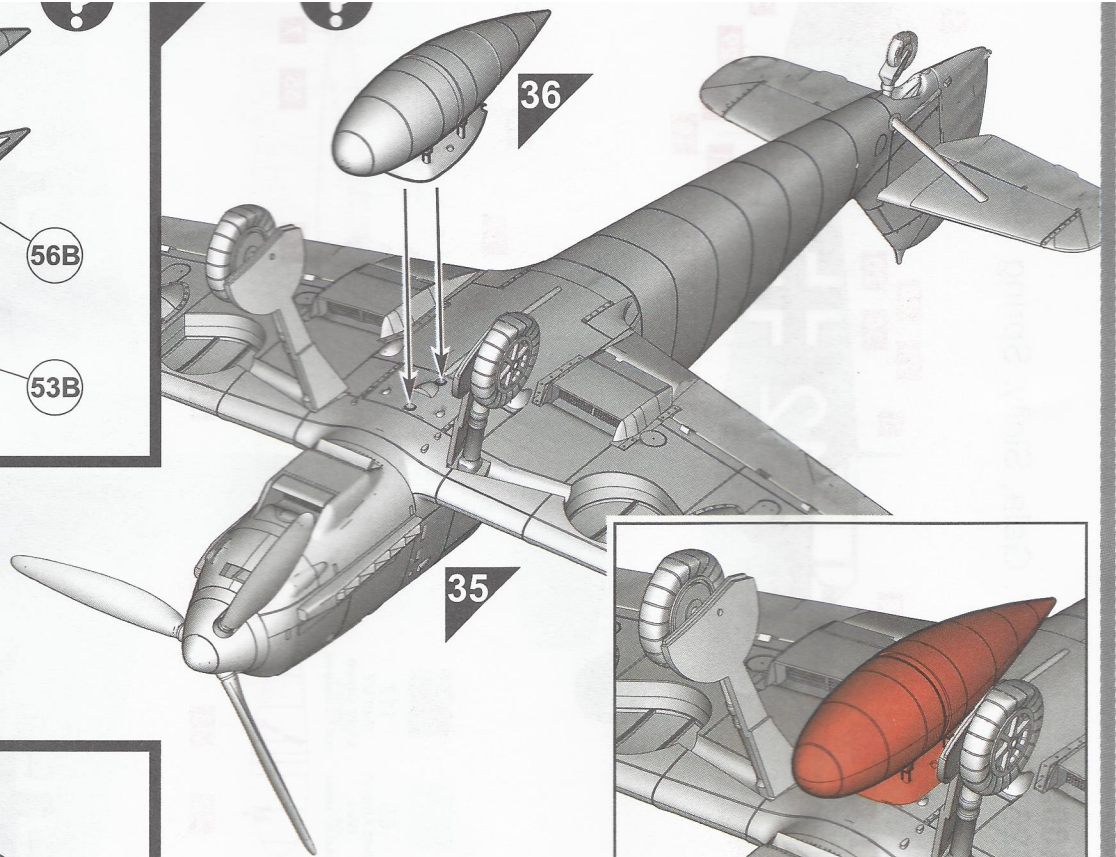
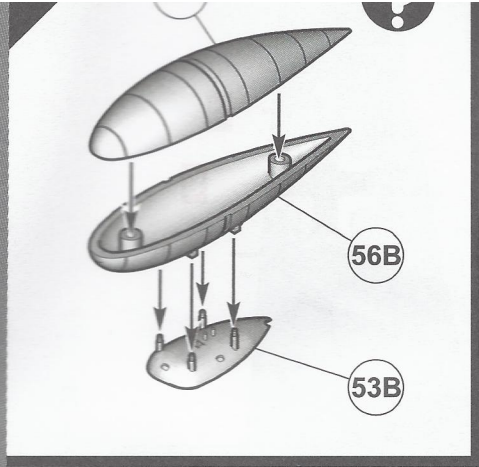

B Messerschmitt Bf 109E-7
 Aircraft flown by Oberleutnant Joachim Müncheberg. 7./JG26 "Schlageter", Gela, Sicily, Spring 1941.

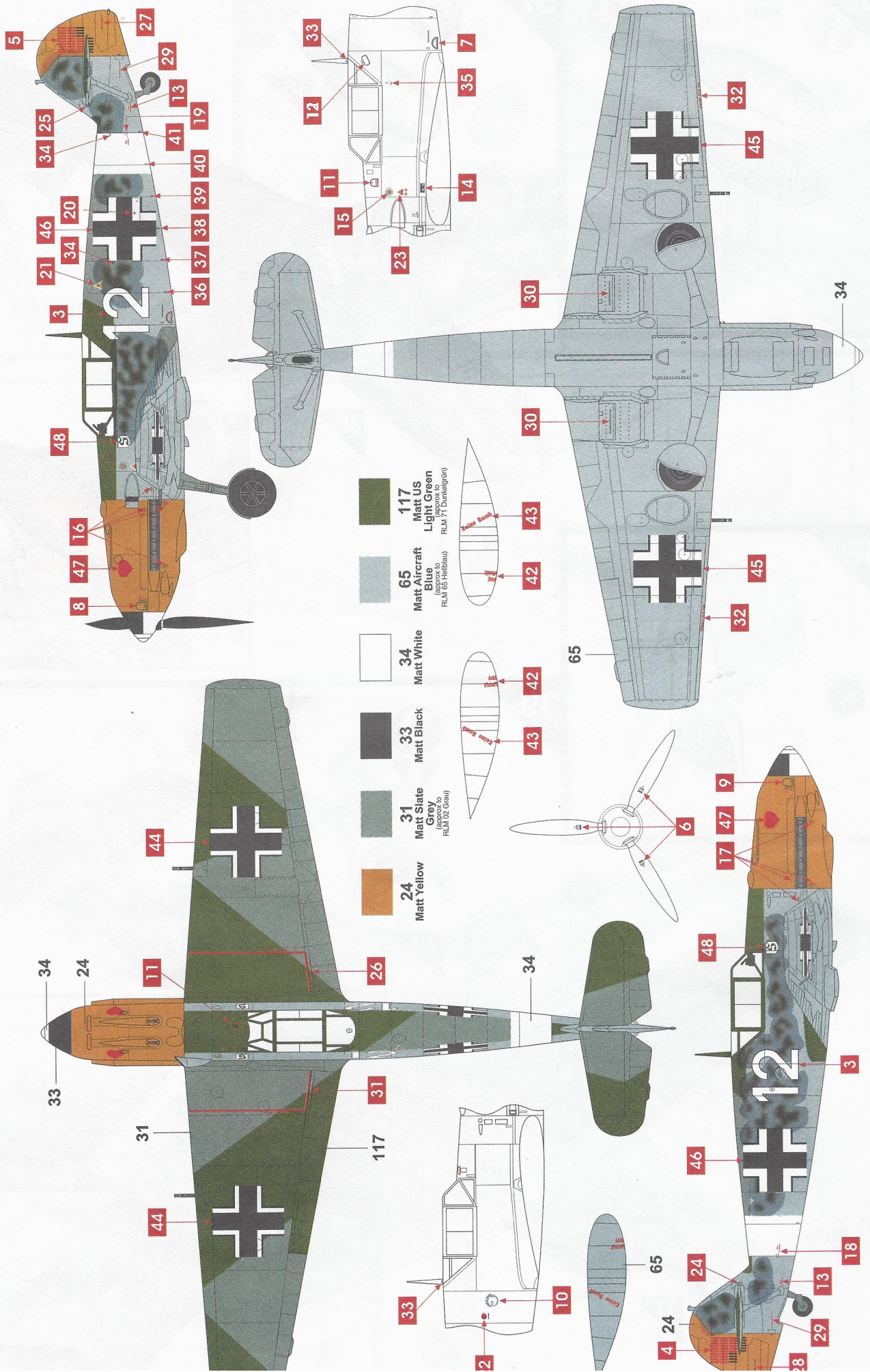

Spitfire Vb

LOCATION FOR WING TIP STEADYING TRUSTLE

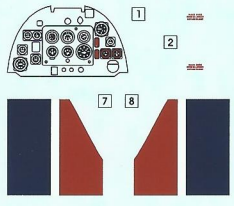

EP64I
EP64I

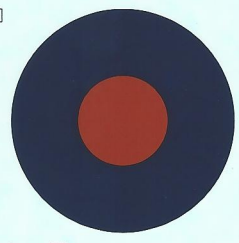
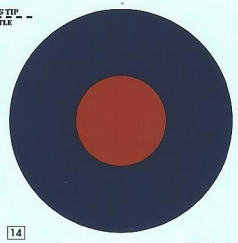

WALKWAY INBOARD

NOT TO BE WALKED ON

NOT TO BE WALKED ON

WALKWAY FORWARD

100 OCTANE CAPACITY 65 GALLS.



X  JJ  X

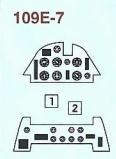

1212

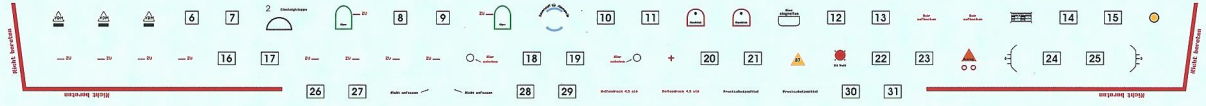

Achtung! Kraftstoffbehälter! Keine Bombe! Keine Bombe!

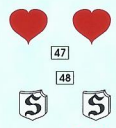
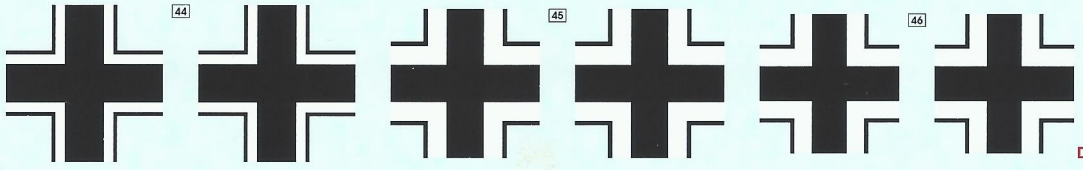

A50160
Dogfight Double