

# Revell

KIT 1180

85118010200

## F-14 TOMCAT

The Grumman F-14 is an air superiority fighter without equal. It has been proven to be one of the most maneuverable combat fighters ever developed. The "Tomcat" utilizes movable, variable geometry wings to provide maximum performance over a broad spectrum of flight characteristics. The F-14 is equipped with an array of sophisticated systems that transforms it into a lethal combat aircraft.

The F-14 is a two seat aircraft capable of speeds in excess of Mach two. The aircraft is powered by two Pratt and Whitney TF-30 Turbofan engines that develop nearly 21,000 pounds of thrust each. The "Tomcat" is 62 feet long and has a wingspan of 61 feet, 10 inches.

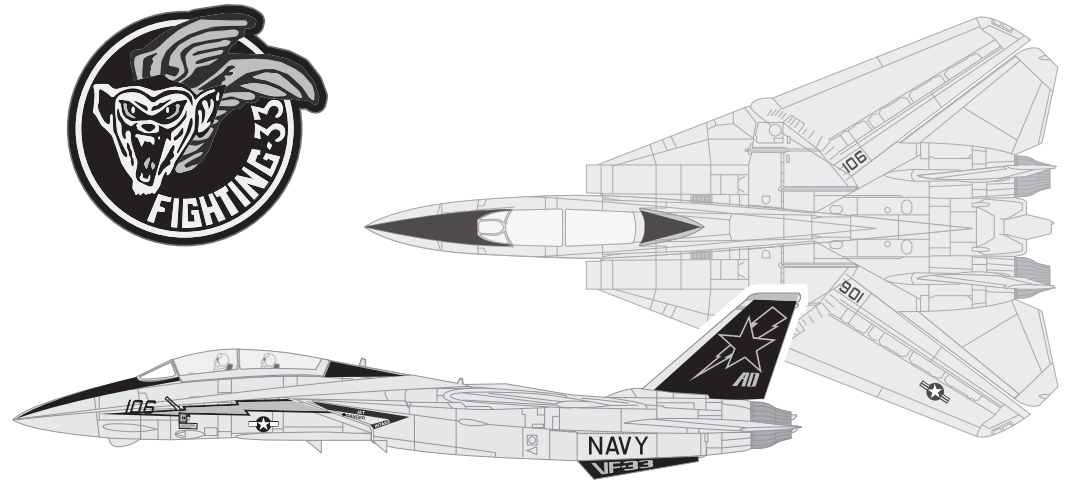

\* REPEAT SEVERAL TIMES  
\* A REPETER PLUSIEURS FOIS



\* REMOVE AND THROW AWAY  
\* A RETIRER ET JETER



\* APPLY STICKERS  
\* APPLIQUEZ LES AUTO-COLLANTS



\* TRIM  
\* D'ECOUPER



\* OPTIONAL PARTS  
\* PIECES EN OPTION

### READ BEFORE YOU BEGIN

- CLEAR A SPACE TO WORK ON.
- STUDY THE ASSEMBLY DRAWINGS BEFORE YOU BEGIN.
- EACH PLASTIC PART IS IDENTIFIED BY A PART NUMBER.
- THIS KIT MAY BE SNAPPED TOGETHER BUT PARTS MAY BE CEMENTED IF YOU PREFER.
- TRIM TO REMOVE EXTRA PLASTIC AND FILE SMOOTH BEFORE PART ASSEMBLY.

#### CAUTION:

POSITION ALL PARTS IN THIS KIT CAREFULLY.  
PARTS WILL ONLY SNAP TOGETHER ONCE.

- DÉGAGEZ UN ESPACE POUR TRAVAILLER.
- ÉTUDIEZ LES ÉTAPES DE MONTAGE AVANT DE COMMENCER.
- CHAQUE PIÈCE EN PLASTIQUE PORTE UN NUMÉRO DE PIÈCE.
- CETTE MAQUETTE L'ASSEMBLAGE PAR SIMPLE PRESSION, MAIS VOUS POUVEZ COLLER LES PIÈCES SI VOUS LE PREFEREZ.
- D'ECOUPER POUR ENLEVER LE PLASTIQUE SUPERFLU ET BIEN LIMER DES PIÈCES AVANT L'ASSEMBLAG

#### MISE EN GARDE:

POSITIONNEZ AVEC PRÉCAUTION TOUTES LES PIÈCES DE CE MODÈLE RÉDUIT, CAR VOUS NE POUVEZ LES EMBOÏTER QU'UNE SEULE FOIS.

If you have any questions or comments, call our hotline at: **(800) 833-3570**  
or, please write to:

**Revell Inc Consumer Service Department, 1850 Howard Street Unit A, Elk Grove Village, Illinois 60007**

*Be sure to include the plan number (85118010200), part number, description, your return address and phone number.*

Visit our website: [www.revell.com](http://www.revell.com)

# Step 1

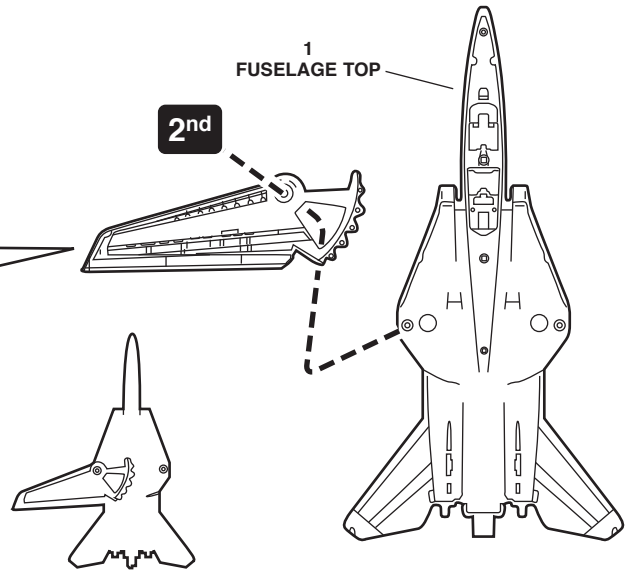
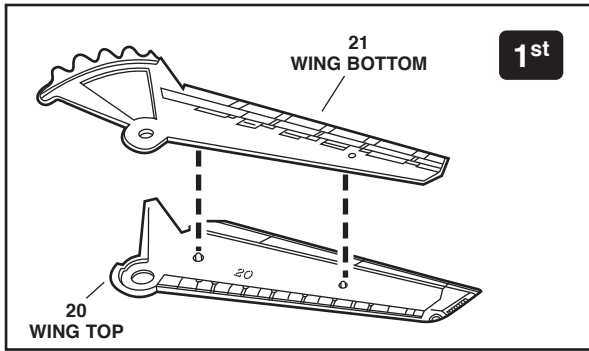

# Step 2

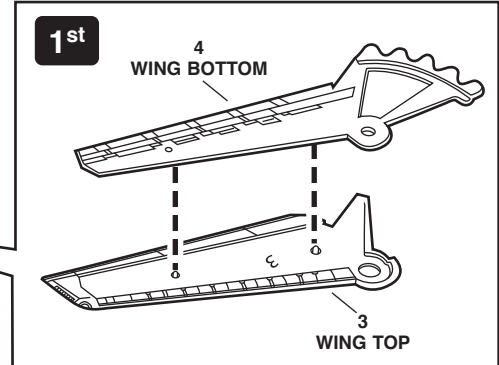
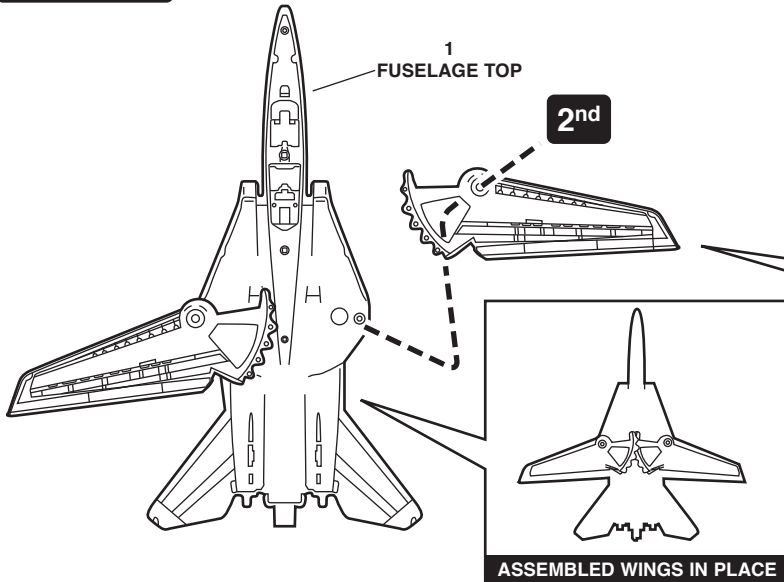

# Step 3

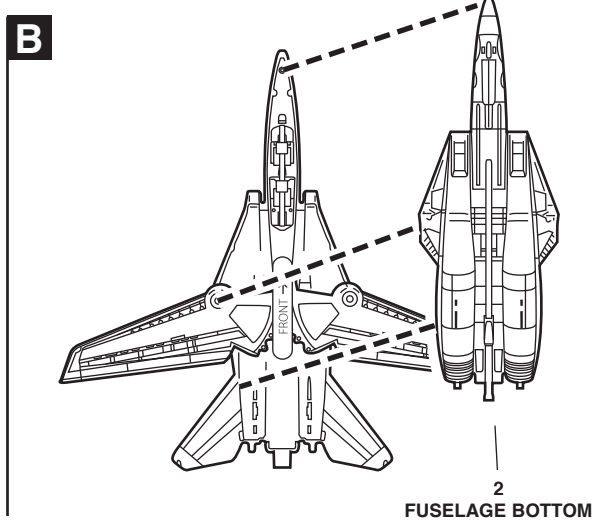
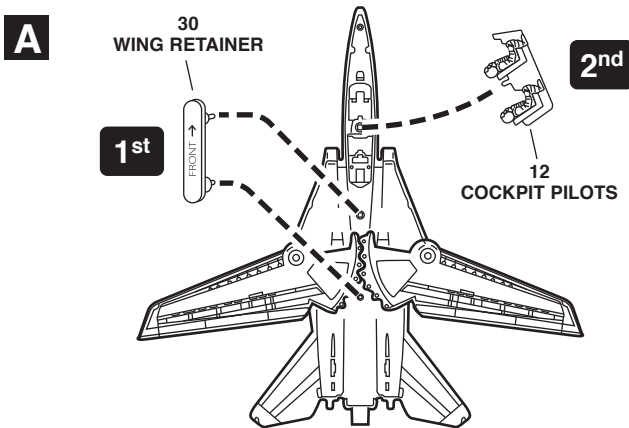

**NOTE: CAREFULLY SNAP WING RETAINER INTO PLACE, TRAPPING WINGS AGAINST THE FUSELAGE. MAKE SURE THE WINGS ARE ALIGNED PROPERLY.**

# Step 4

**A**

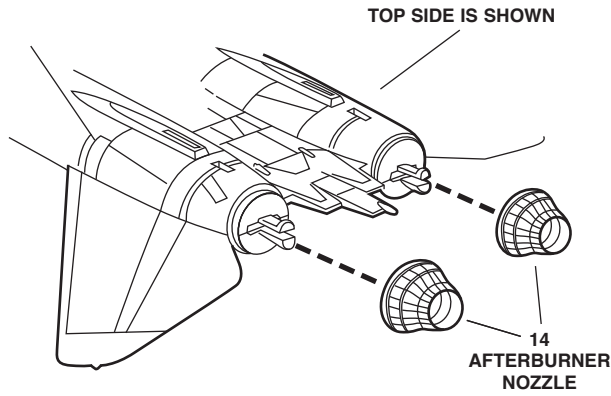

**B**

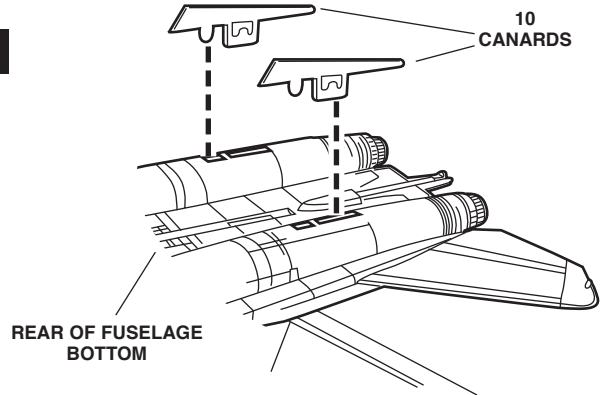

**C**

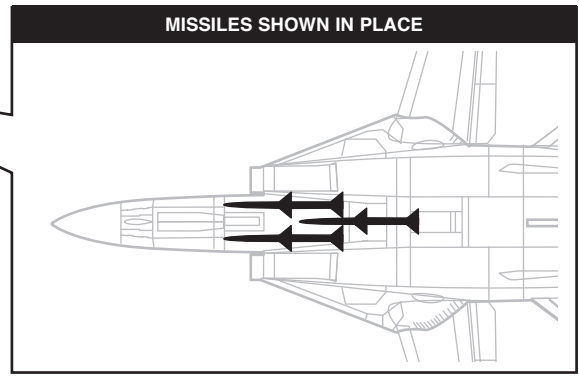
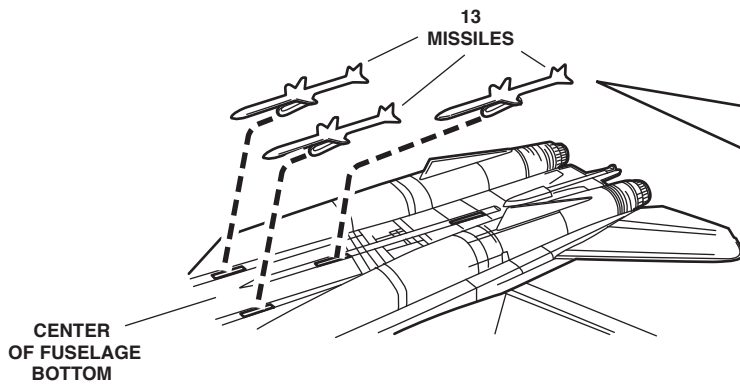

# Step 5

**A**

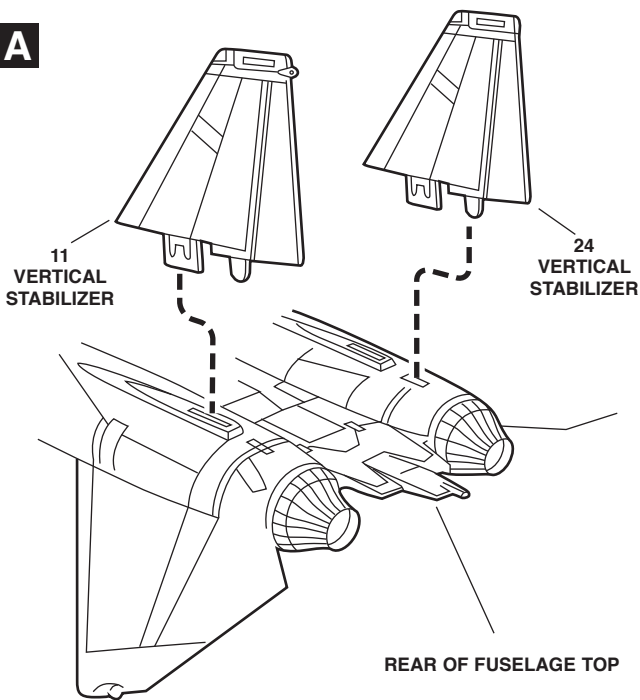

**B**

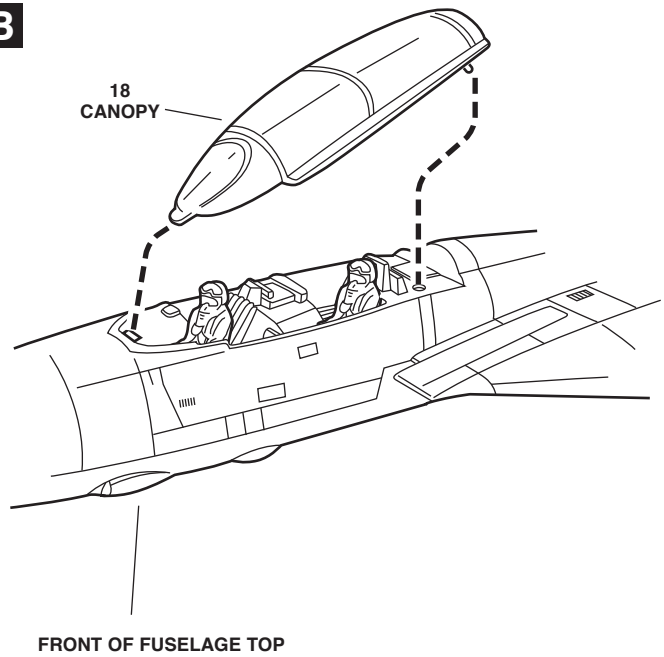

## Step 6

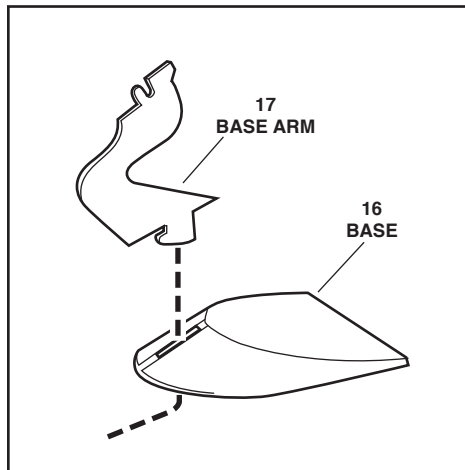

NOTE: AFTER SLIDING PART # 17 INTO PART #16, SLIDE BACK TO LOCK INTO PLACE.

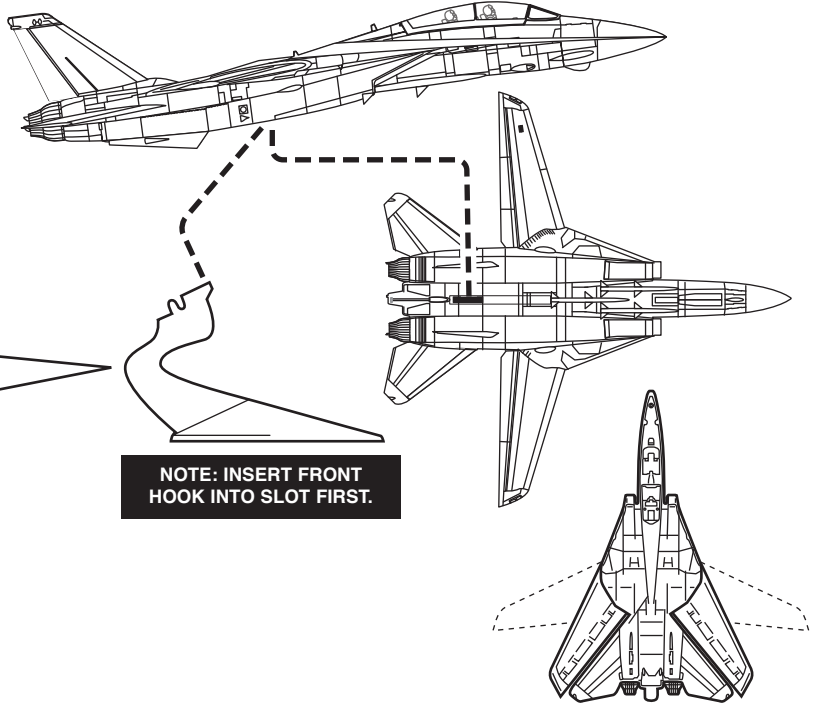

## Step 7

Bonus stickers are included on the sticker sheet. You may place them wherever you like on your model or wherever you want!

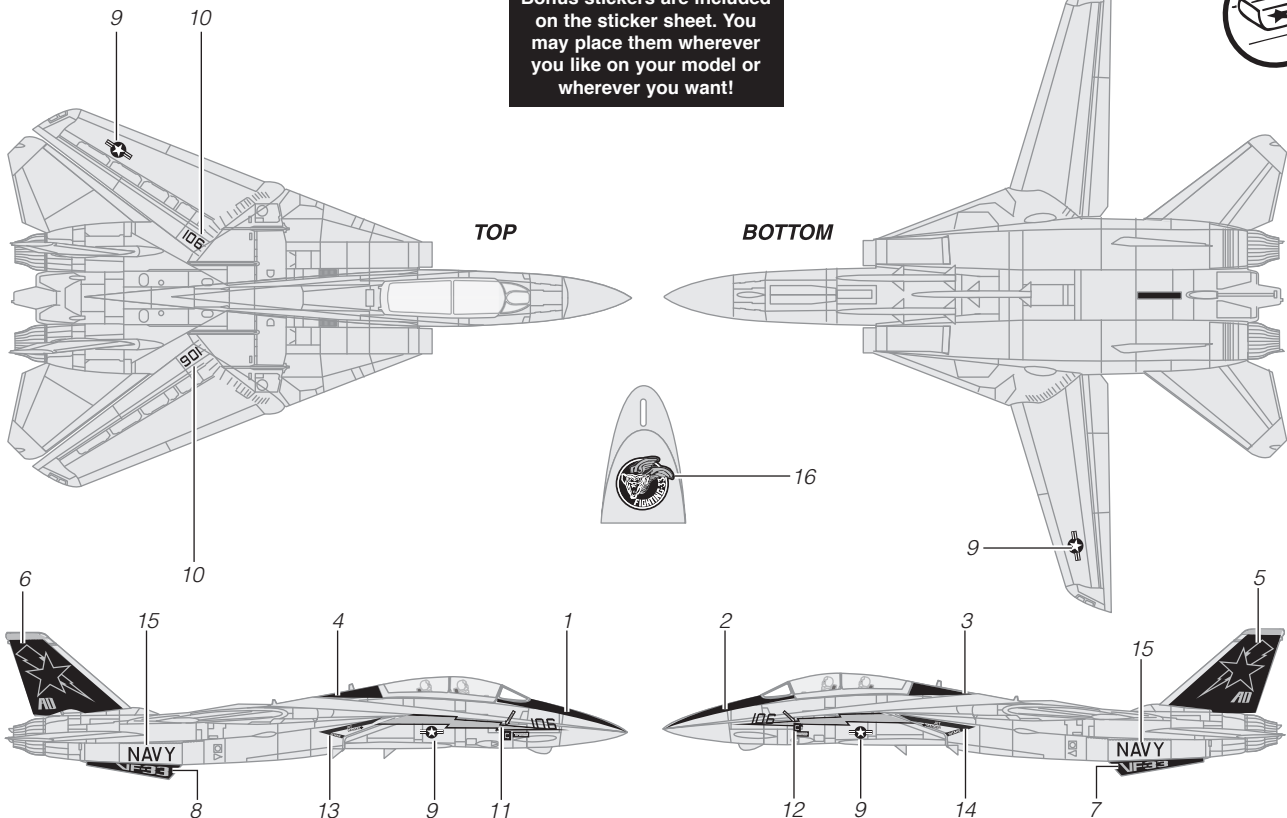

NOTE: When applying stickers, avoid touching the "sticky" side to prevent finger prints on stickers. Bend sticker sheet slightly to lift edge of sticker & use a finger nail to lift sticker from sheet. Line up sticker on body and press an edge into place, slowly working sticker with a finger nail until sticker is fully on model.

REMARQUE : Pendant l'application des autocollants, éviter de toucher à la face collante pour ne pas laisser d'empreintes. Plier légèrement la feuille d'autocollants pour relever le bord d'un autocollant, et le détacher de la feuille avec le bout d'un angle. Aligner l'autocollant sur la carrosserie, appuyer pour coller un de ses bords, et continuer de l'appliquer lentement du bout de l'angle jusqu'à ce qu'il soit complètement collé sur le modèle réduit.