

# HAWKER SIDDELEY GR.3 HARRIER

## OPERATION CORPORATE



MKM14499  
1/144 scale

MARK I Ltd.  
PO Box 10  
Prague 10 - Strašnice  
CZ-100 31  
Czech Republic  
mark1@cmail.cz  
www.4pluspublications.com

plastic parts

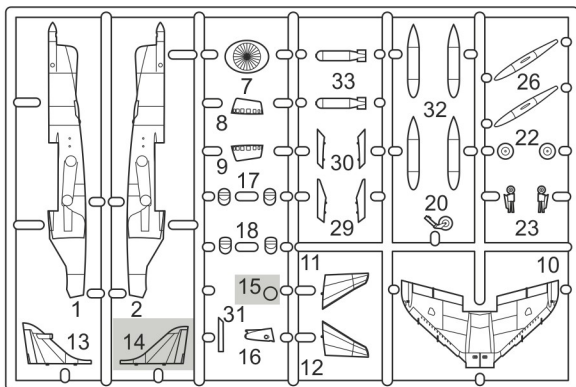

clear part

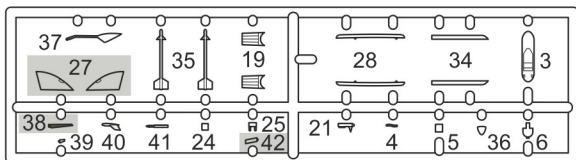
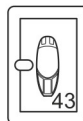

- 2x Repeat this operation
- Glue
- Don't glue
- Decal
- Detach/cut
- Optional

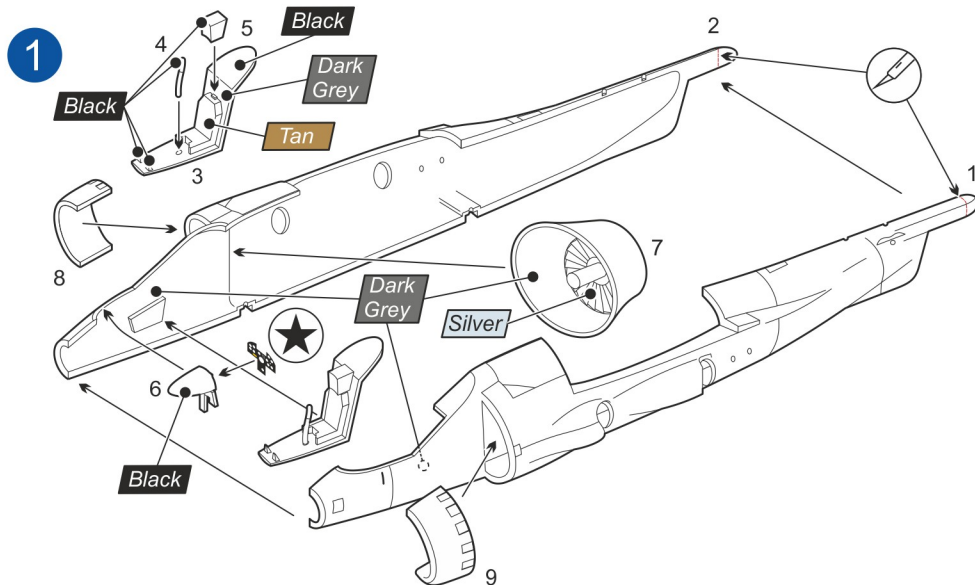

2

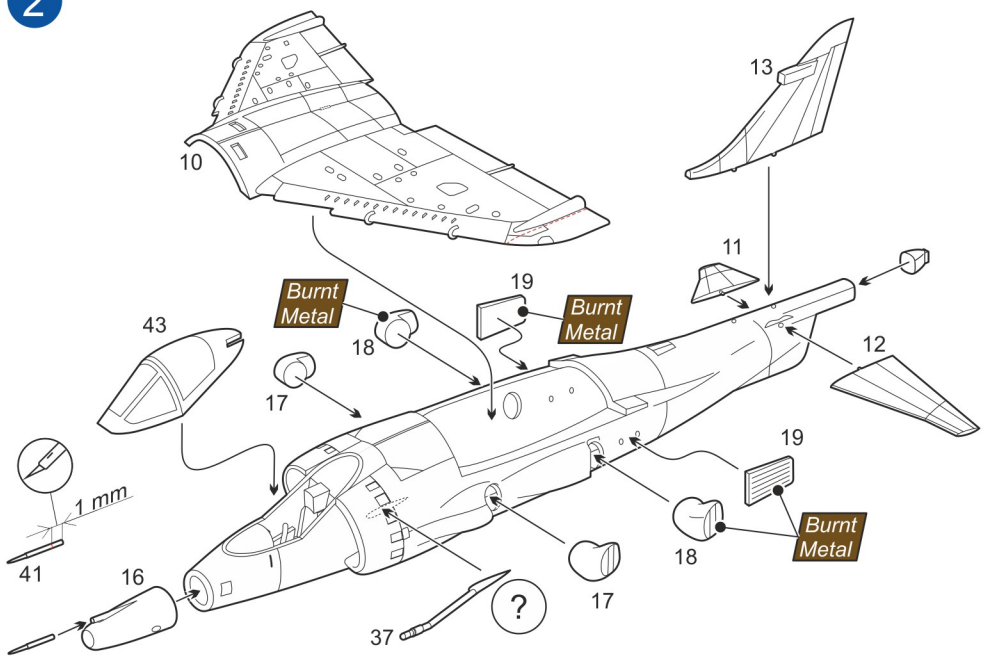

3

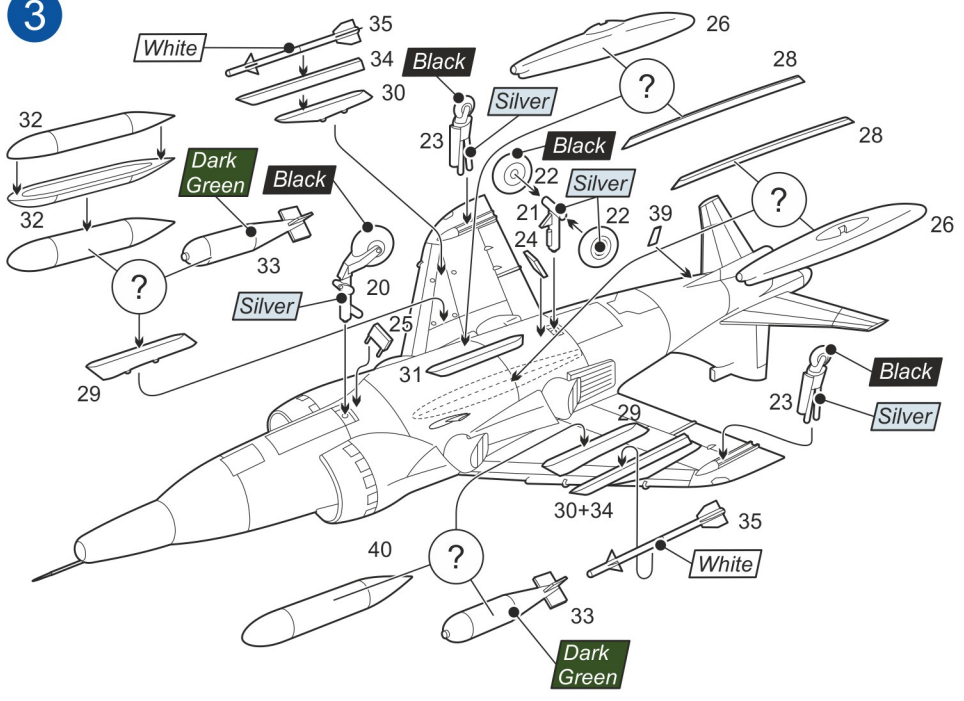

**A**

Hawker Siddeley Harrier GR Mk.3, XV789, Red 32, No.1(F) Sq., RAF, HMS Hermes, FOB (Forward Operating Base) Port San Carlos and Port Stanley Airport, during 'Operation Corporate', the Falkland Islands, May-June 1982

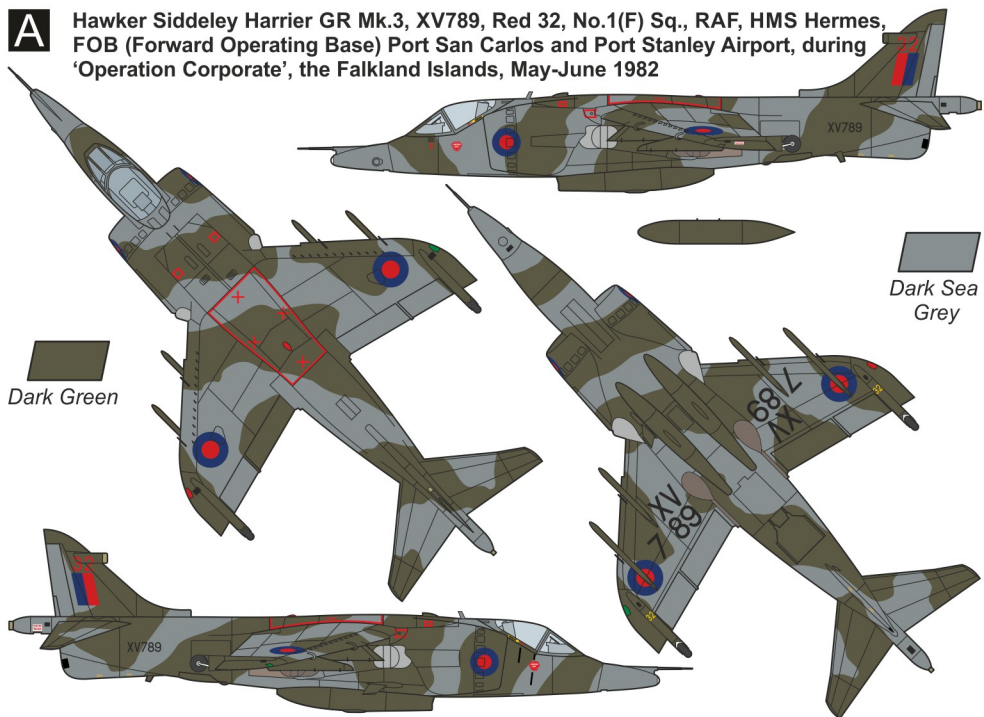
**B**

Hawker Siddeley Harrier GR Mk.3, XZ963, Red 14, No.1(F) Sq., RAF, HMS Hermes, FOB (Forward Operating Base) Port San Carlos and Port Stanley Airport, during 'Operation Corporate', the Falkland Islands, May-June 1982

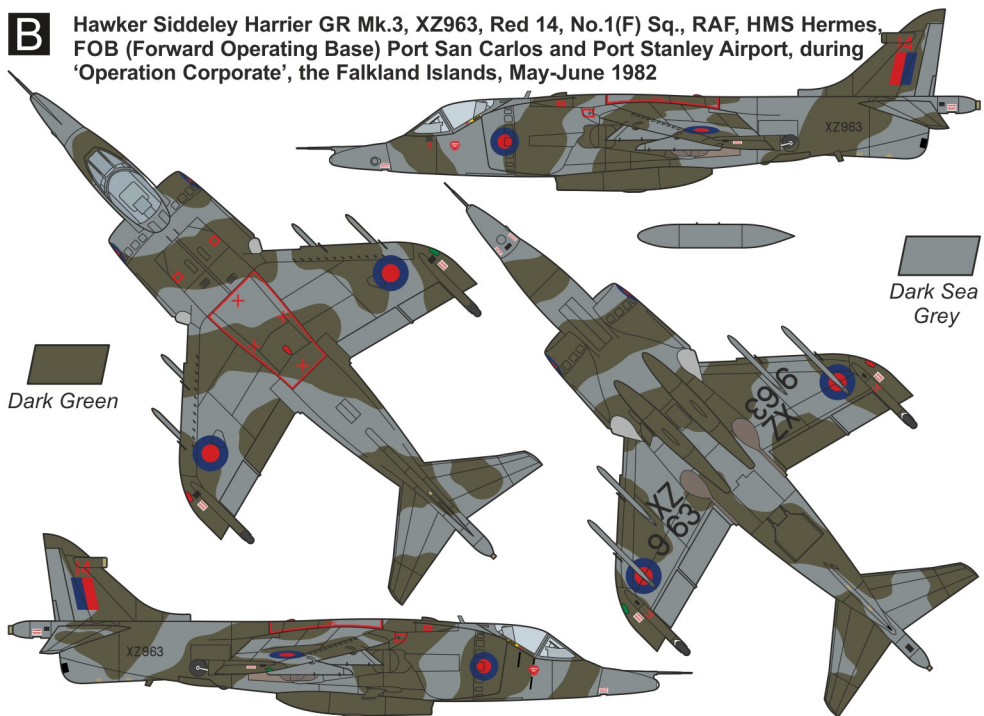

**C**

Hawker Siddeley Harrier GR Mk.3, XZ972, Red 33, No.1(F) Sq., RAF, HMS Hermes, FOB (Forward Operating Base) Port San Carlos and Port Stanley Airport, during 'Operation Corporate', the Falkland Islands, May-June 1982

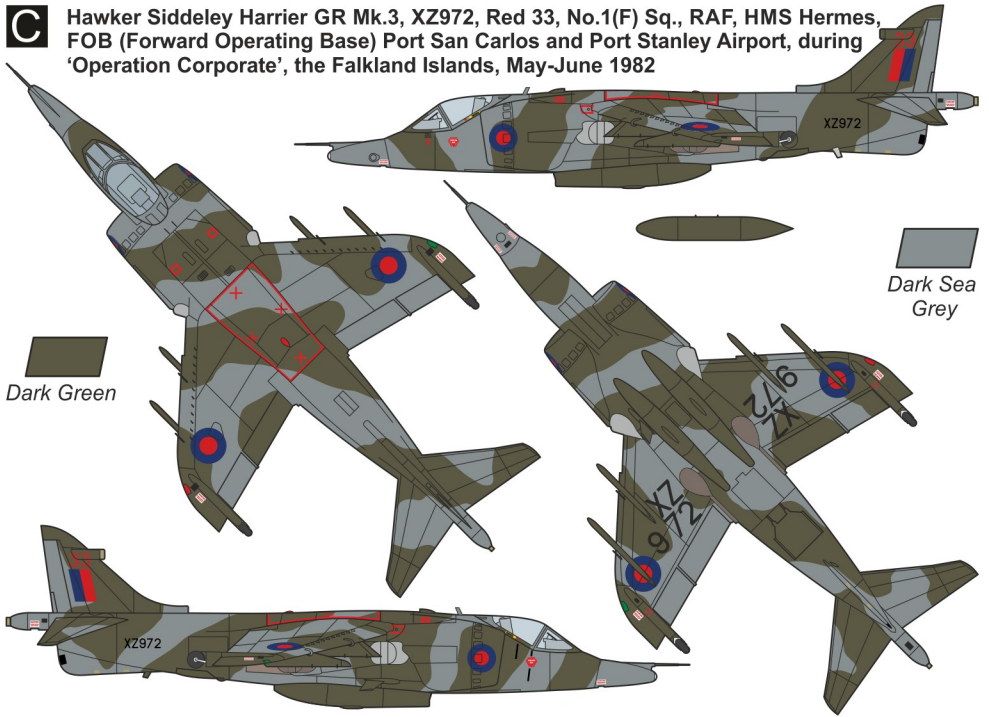
**D**

Hawker Siddeley Harrier GR Mk.3, XZ989, Red 07, No.1(F) Sq., RAF, HMS Hermes, FOB (Forward Operating Base) Port San Carlos and Port Stanley Airport, during 'Operation Corporate', the Falkland Islands, May-June 1982

