

Wolfpack

www.wolfpack-d.com

T-38C Talon "USAF"

T-38A 탈론 '미공군'



The T-38 Talon is a supersonic jet trainer by Northrop. It was the world's first supersonic trainer and is also the most produced jet trainers. The United States Air Force is the largest operator of the T-38 series, training missions for USAF pilots, Navy Test pilots and NASA Astronaut. Besides the USAF, the other operators included the RoCAF, Portuguese AF, Turkish AF, RoKAF and Luftwaffe(German AF)

As of 2012, the T-38 has been in service for over 50 years with USAF. In 2015, 504 T-38s were still operational with the USAF. Most of the USAF variant aircraft (T-38A and AT-38B) have been converted to the T-38C through an avionics upgrade program. Improvements include the addition of a HUD, GPS, INS (Inertial Navigation System), and TCAS. Most jets have also received PMP (a propulsion modification to improve low-altitude engine thrust). Approximately a third of the fleet (those that experience more severe usage) are currently undergoing structural replacements and upgrades, as well as receiving new wings, to extend their service life to 2029.

T-38 탈론은 미국 노스롭사에서 제작한 초음속 제트훈련기로 등장 당시 세계최초의 초음속 훈련기이다. 초음속 제트훈련기로 생산된 비행기 중 최다인 1,139대가 생산되었다. T-38C는 미 공군이 보유한 T-38A와 AT-38B를 대폭 개량하여 디지털 장비의 신형 조종석과 함께 HUD, GPS, INS 등의 항법장치와 TCAS 등 새로운 항전장비를 장착하여 보다 안전한 비행기 가능하게 됐다. 또 PMP 업그레이드를 통해 폭이 넓어진 인테이크와 함께 개량된 제너럴 일렉트릭사의 J85-5R 엔진을 장착하여 추력이 약 15%정도 향상되었다. T-38 탈론은 역대 가장 성공한 초음속 제트훈련기로, 1952년 미 공군에서 처음 사용된 이래 50년이 넘는 현재까지 개량을 거듭해 주력 훈련기로 사용중이다. 미 공군 이외에도 미 해군과 미 우주항공국(NASA)의 우주비행사 훈련용으로 운용중이다. 그 밖에 한국, 대만, 터키, 포르투갈 공군이 운용중이거나 운용했다.

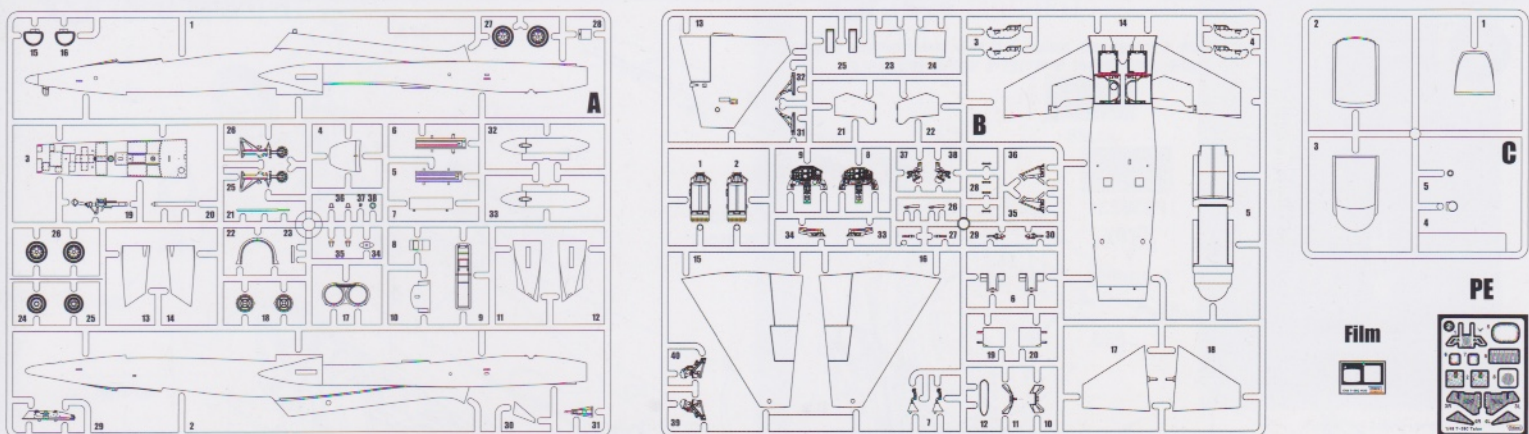

Contains one unassembled model kit only.
No Paint and Cement in box.
Kit suitable for Age to Adult.

조립되지 않은 키트가 들어있습니다.
접착제와 도료는 들어있지 않습니다.
15세 이상 판매용

Wolfpack-Design Co. Ltd.

F2, 352, Gwangdoek 4-ro, Sangroku, Ansan-si, Gyeongudo, 15489, Republic of Korea

울프팩디자인
경기도 안산시 상록구 광덕4로 352, 2중 (우 : 15489)

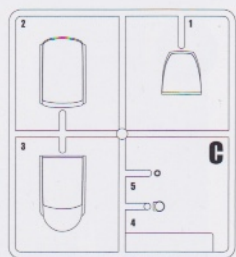
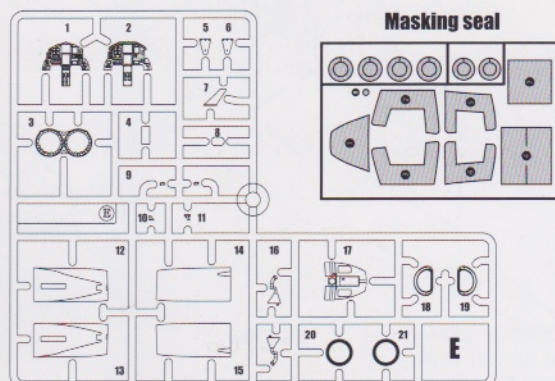

PE



Parts not for use.
(불필요부품)

A20, A21, A23, A24,
A27, A29, A30, A38

B1, B2, B3, B4, B33,
B34, B42

Printed in Korea

5 Bottom fuselage (하체조립)

Anti-collision Light
충돌방지등

Clear Red
C5

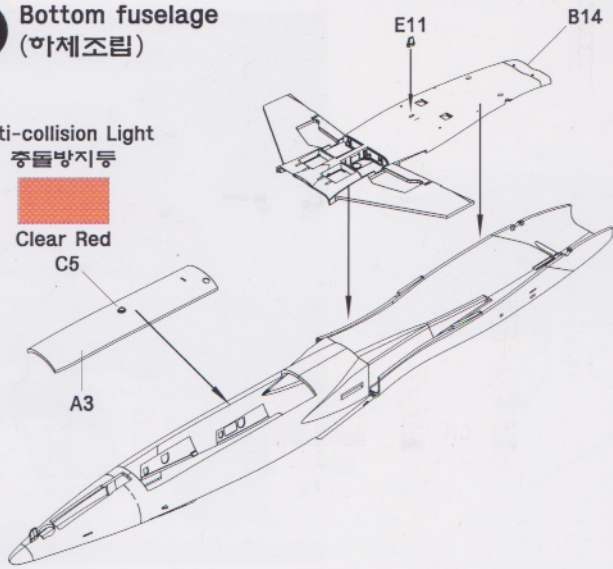

6 Wing assembly (날개조립)

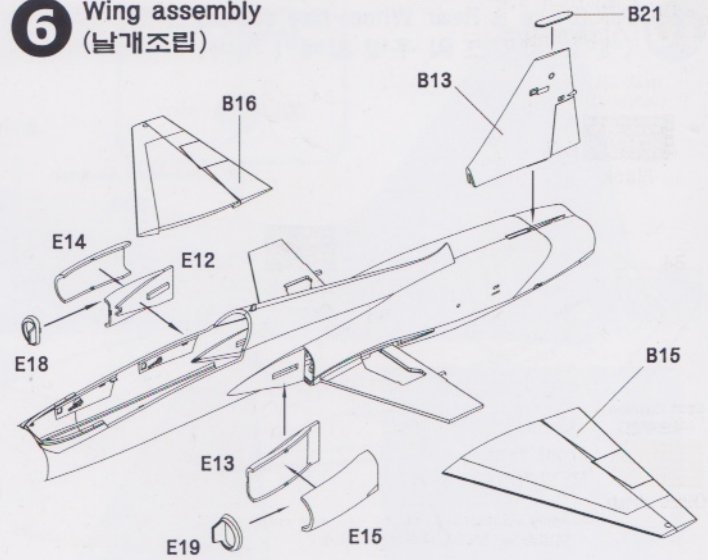

7 Engine Nozzle (엔진노즐 조립)

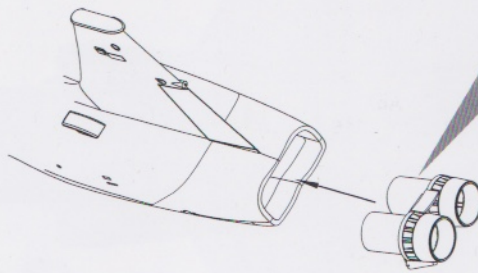
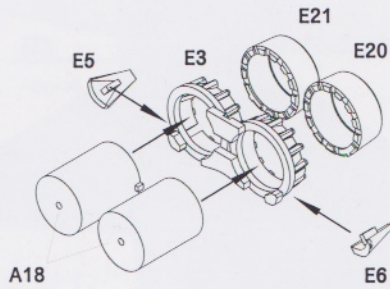
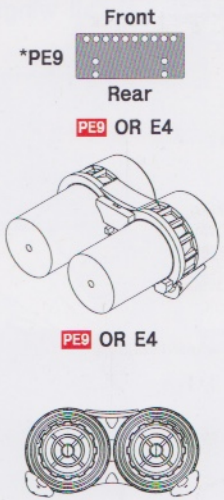
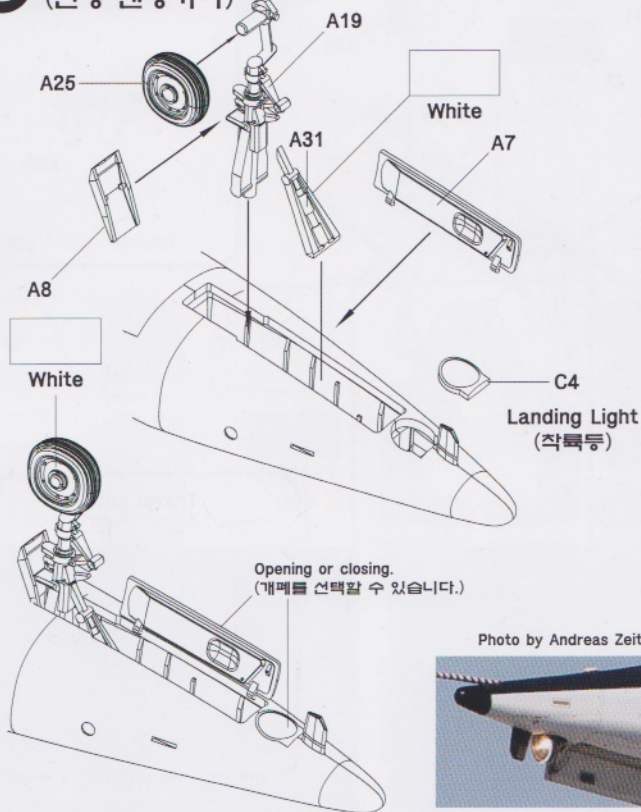

Photo by USAF (www.af.mil)



■ : PE Number (예칭번호)

8 Front Landing gear (전방 랜딩기어)



9 Main Landing gears (동체 랜딩기어)

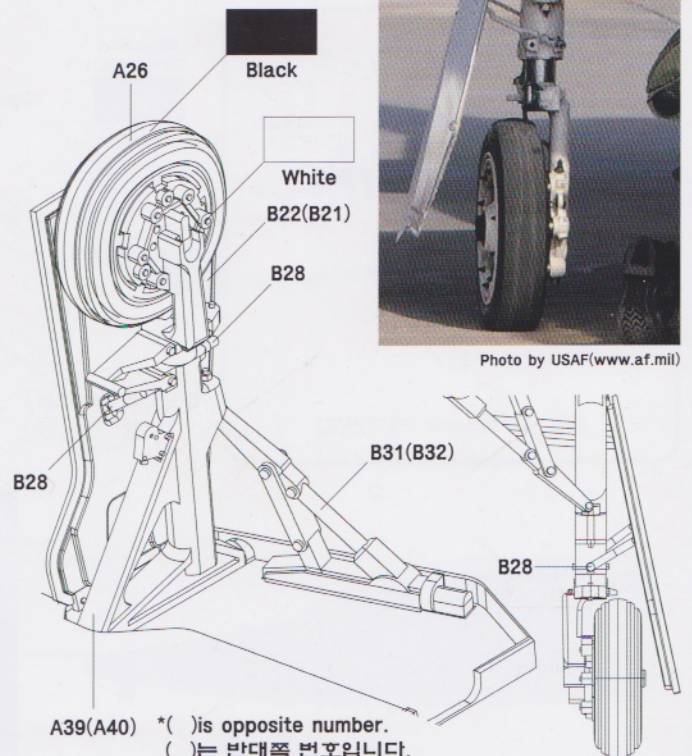

10 Air Brake & Rear Wheel bay covers
(에어브레이크 및 후방 휠베이 커버)

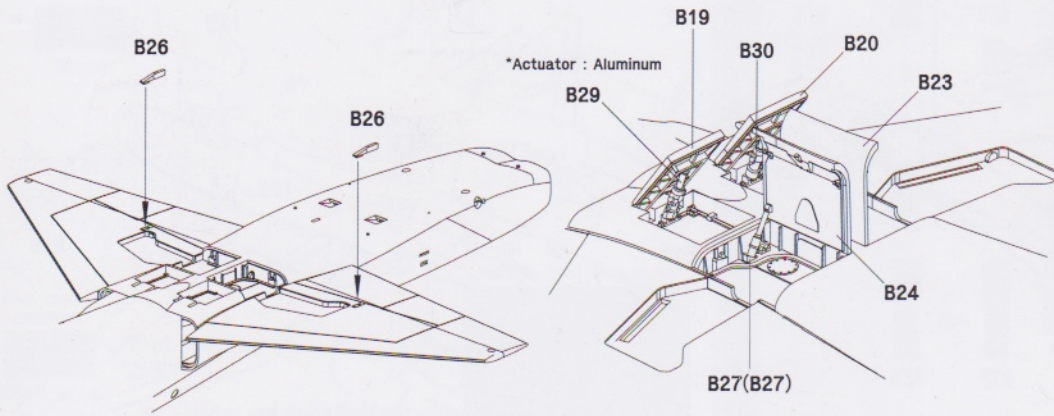
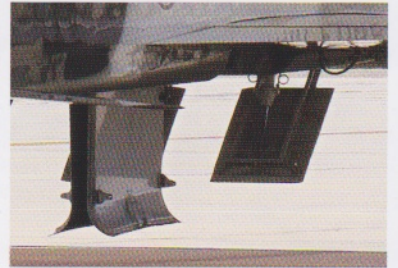
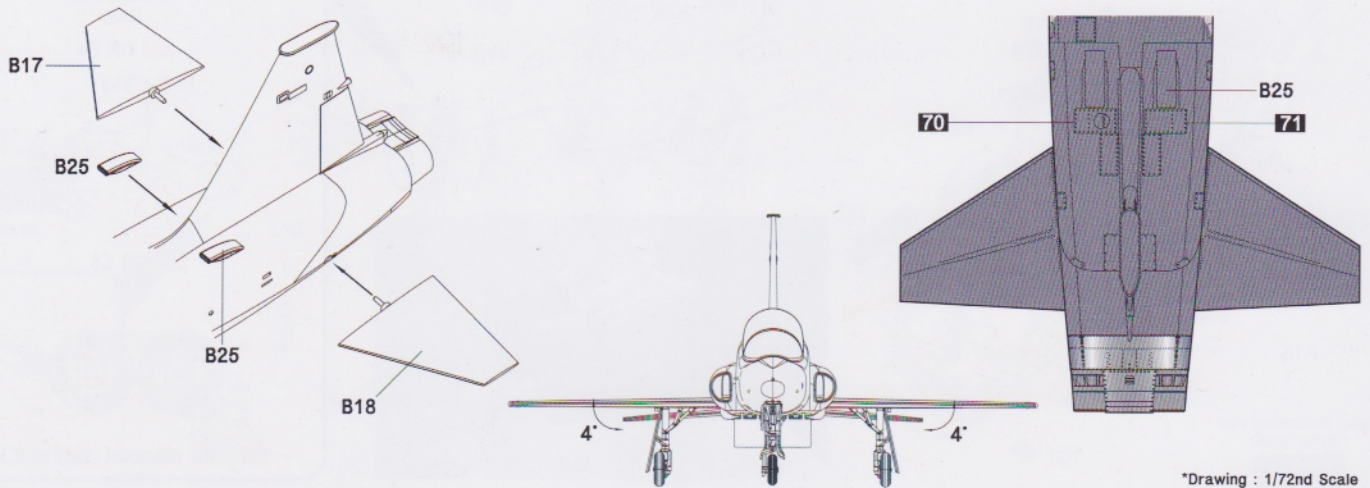

Photo by USAF (www.af.mil)



11 Horizontal tail wings
(수평미익)

■ : Decal number (데칼번호)



*Drawing : 1/72nd Scale

12 HUD & Glareshield
(HUD와 글레어실드)

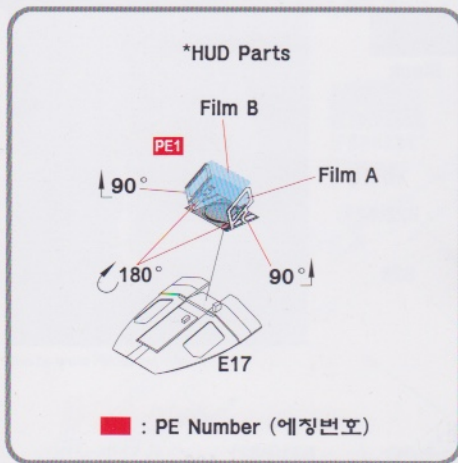

■ : PE Number (예칭번호)

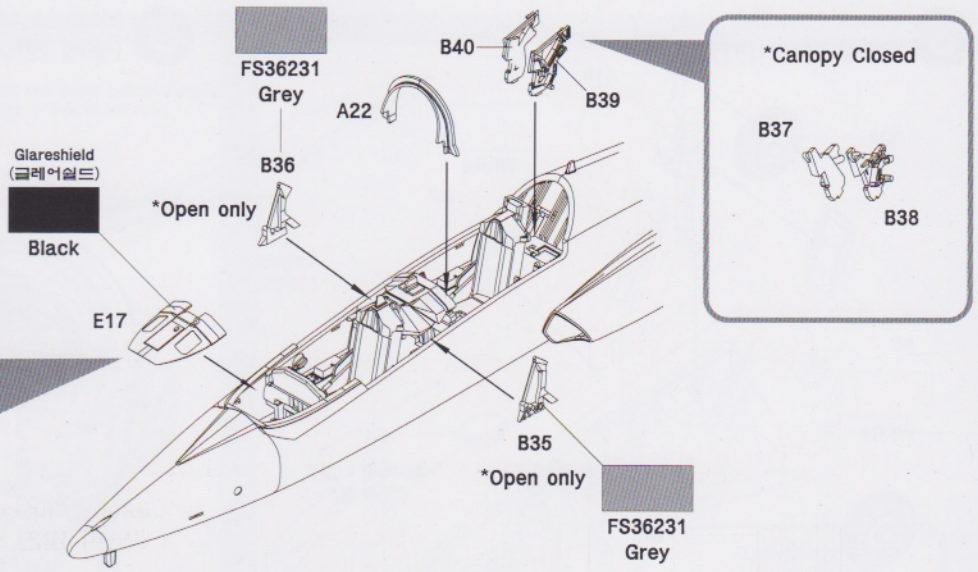

*Canopy Closed

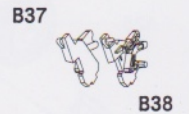
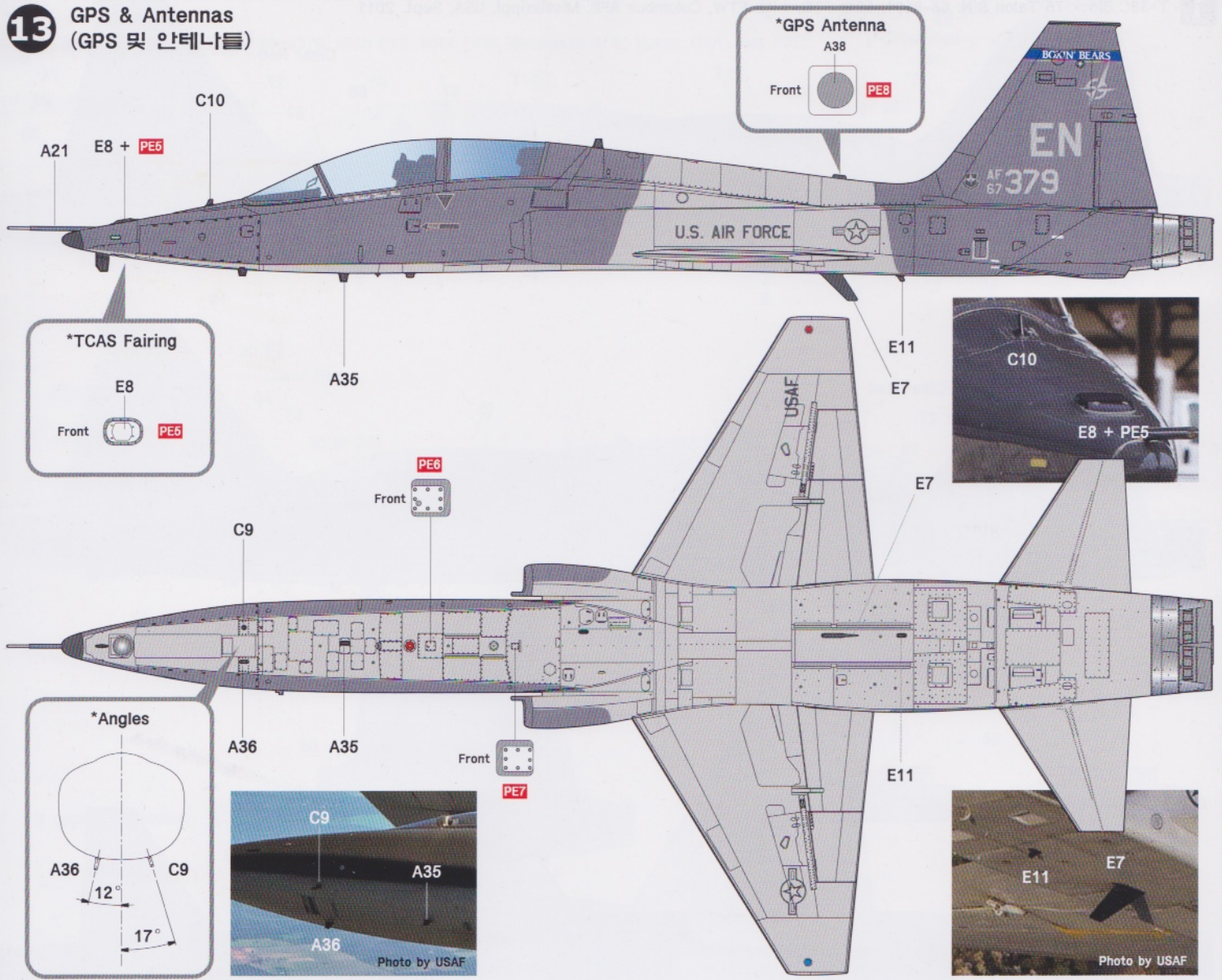
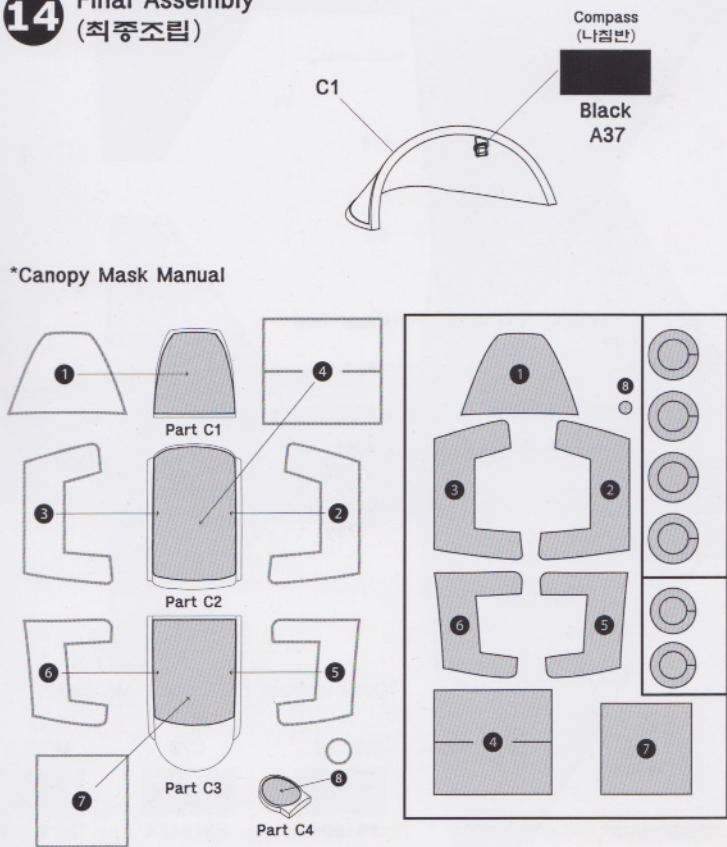

Photo by USAF (www.af.mil)

13 GPS & Antennas (GPS 및 안테나들)



14 Final Assembly (최종조립)



15 Canopy open (캐노피 열린 상태)

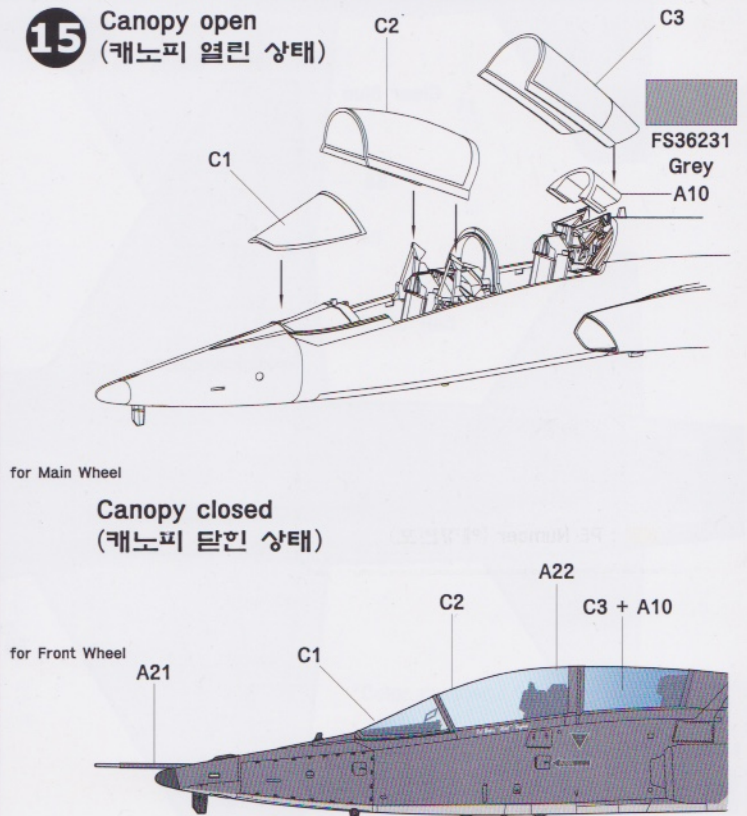

2 T-38C Block 65 Talon S/N: 66-4379, 90th FTS, 80th FTW, Sheppard AFB, Texas, USA, Mar. 2012

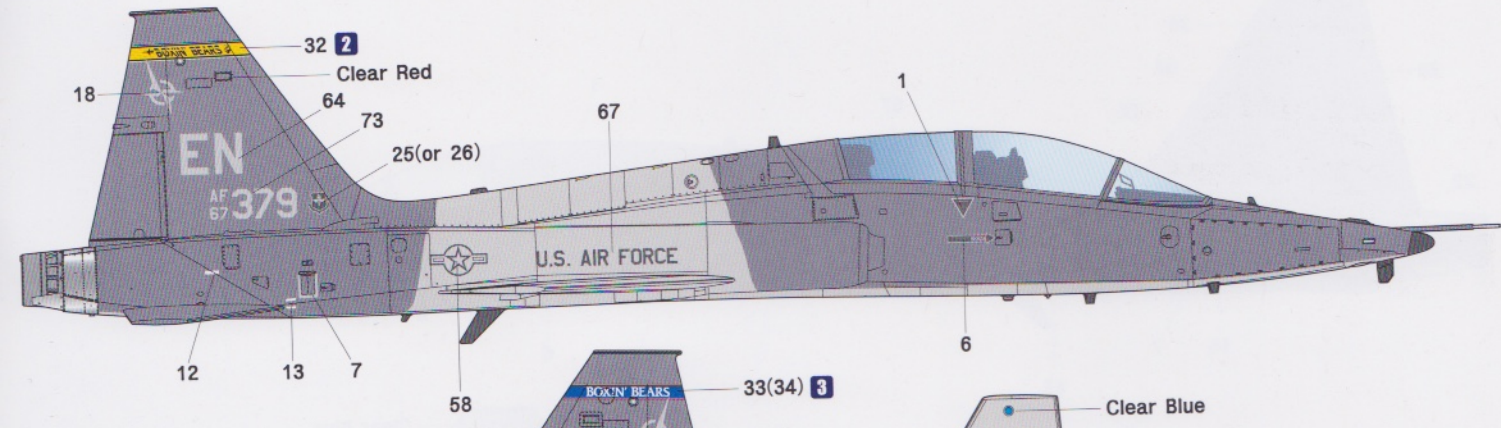
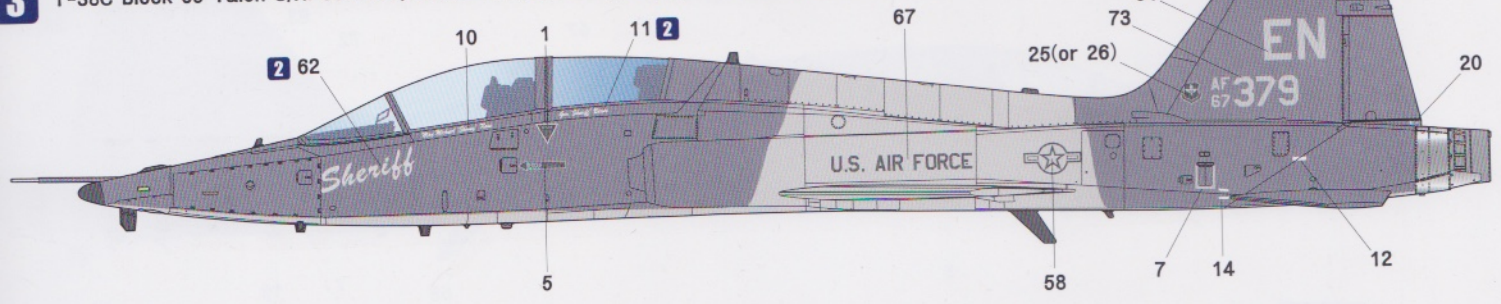

3 T-38C Block 65 Talon S/N: 66-4379, 90th FTS, 80th FTW, Sheppard AFB, Texas, USA, Jan. 2012

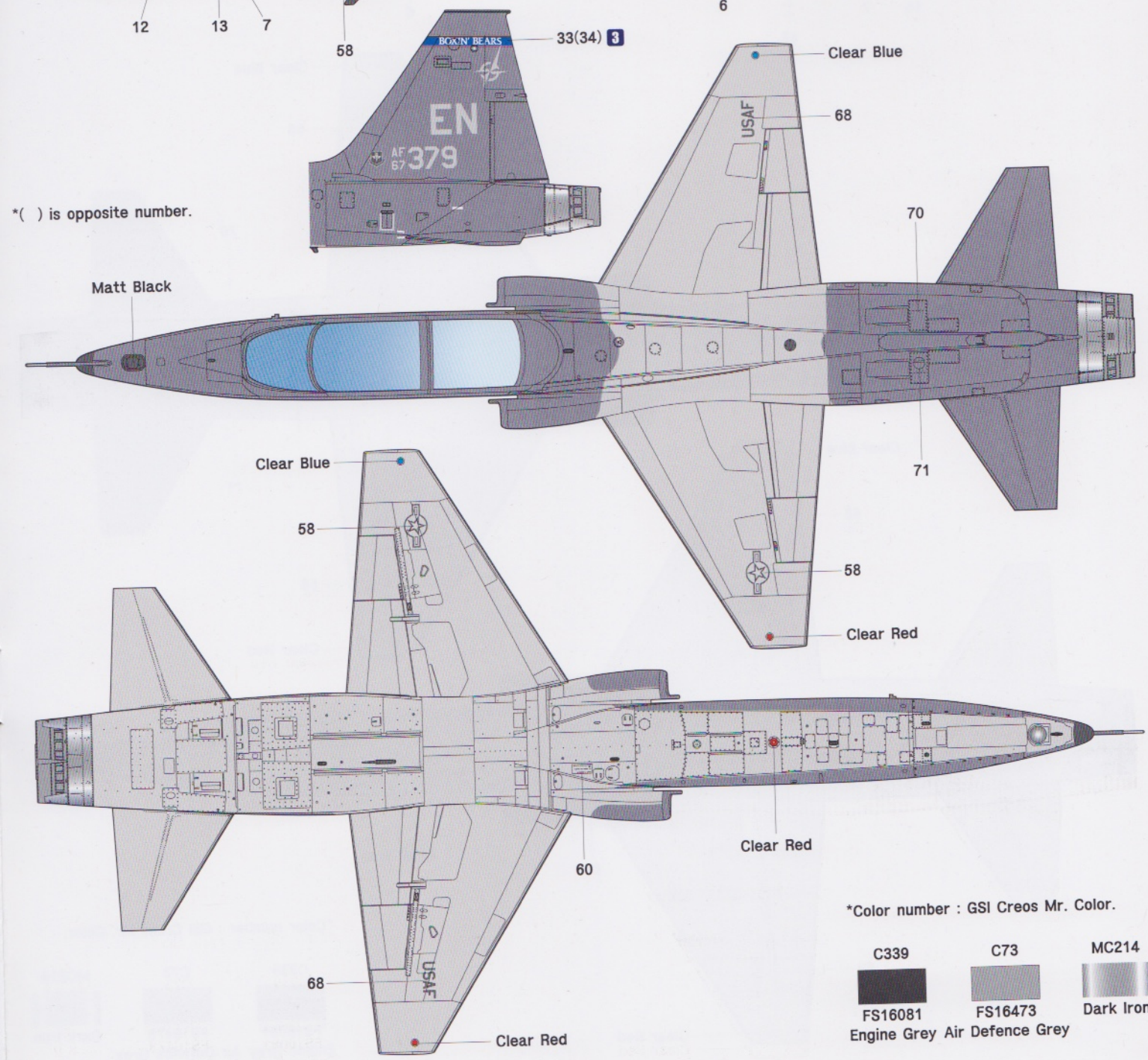

*() is opposite number.



*Color number : GSI Creos Mr. Color.

C339	C73	MC214
		
FS16081	FS16473	Dark Iron
Engine Grey	Air Defence Grey	

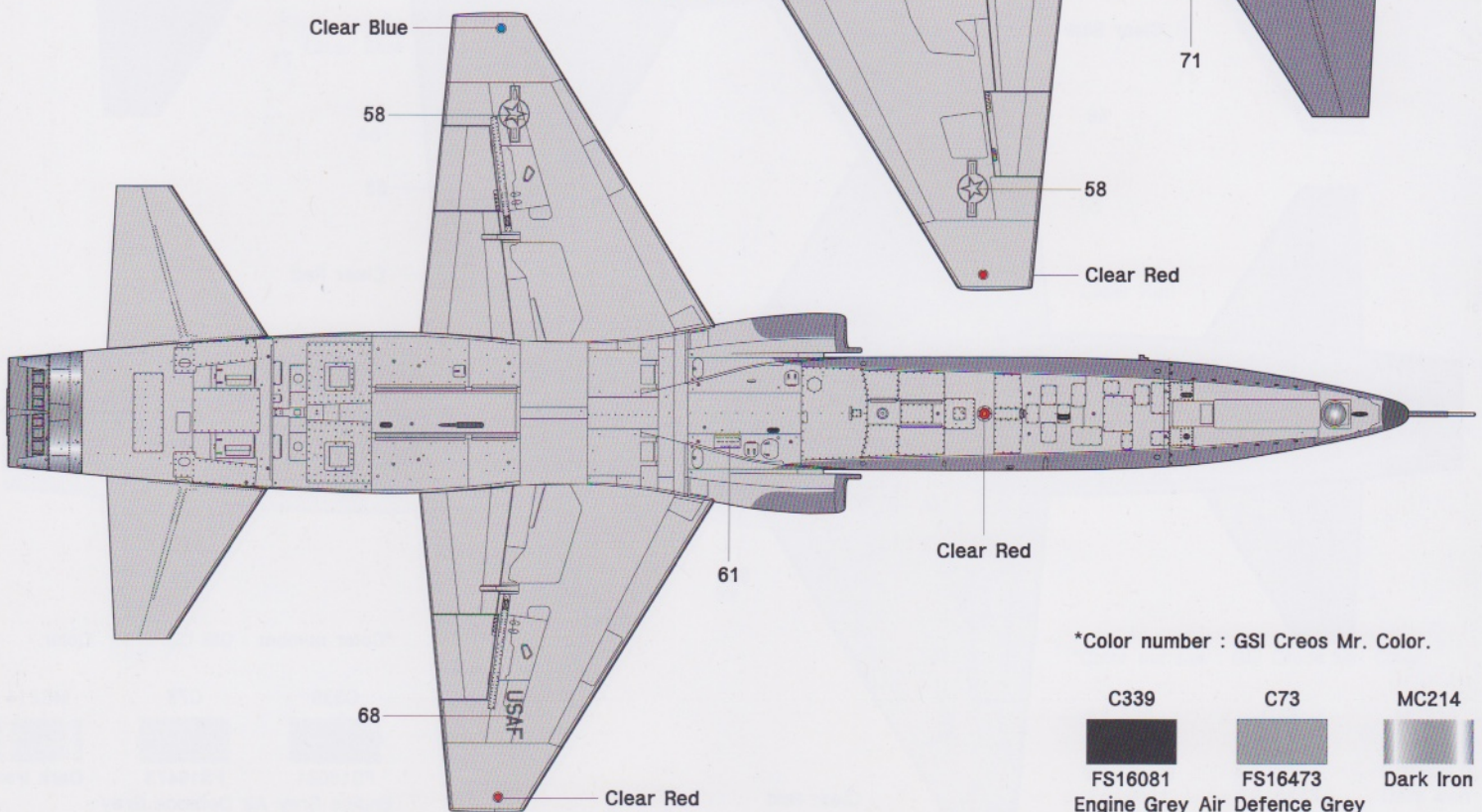
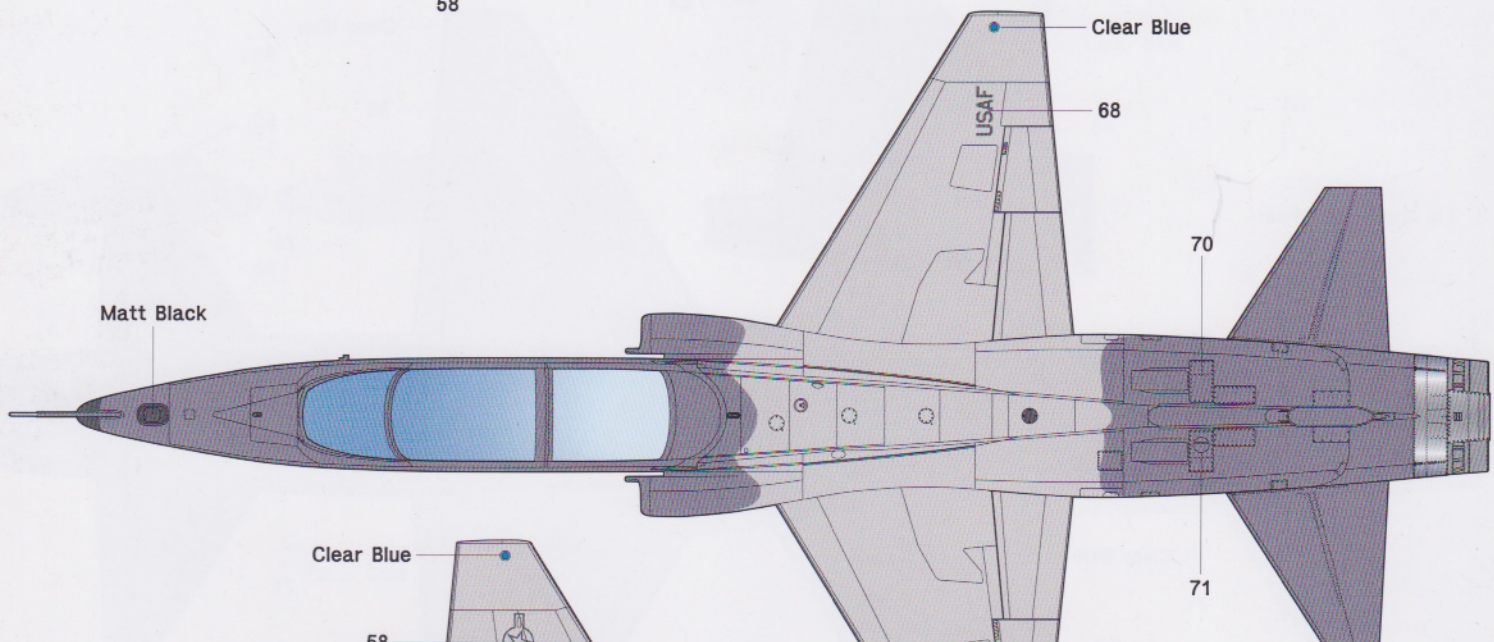
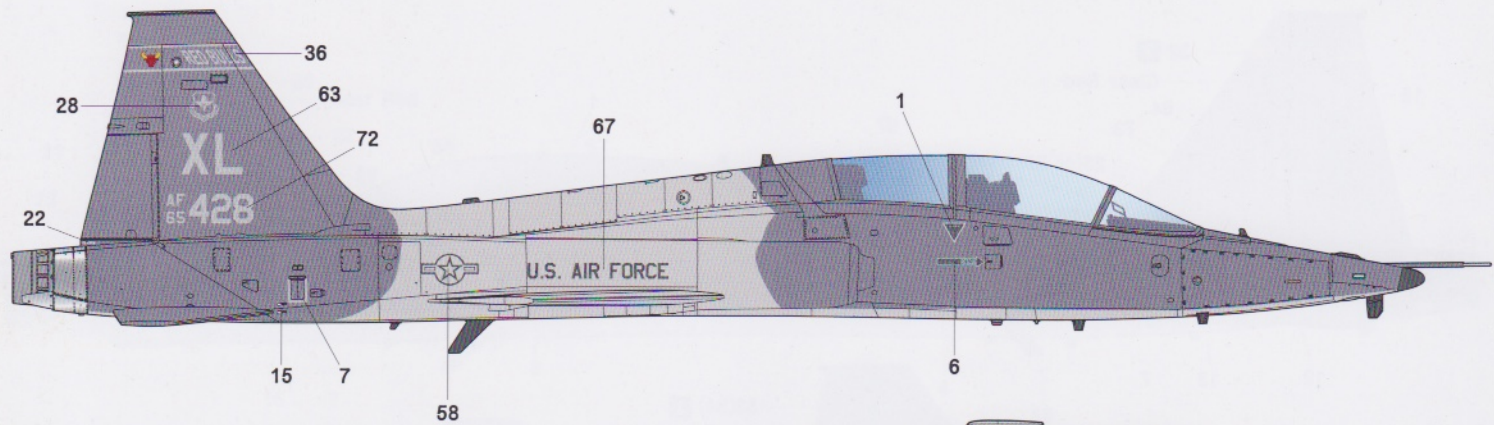
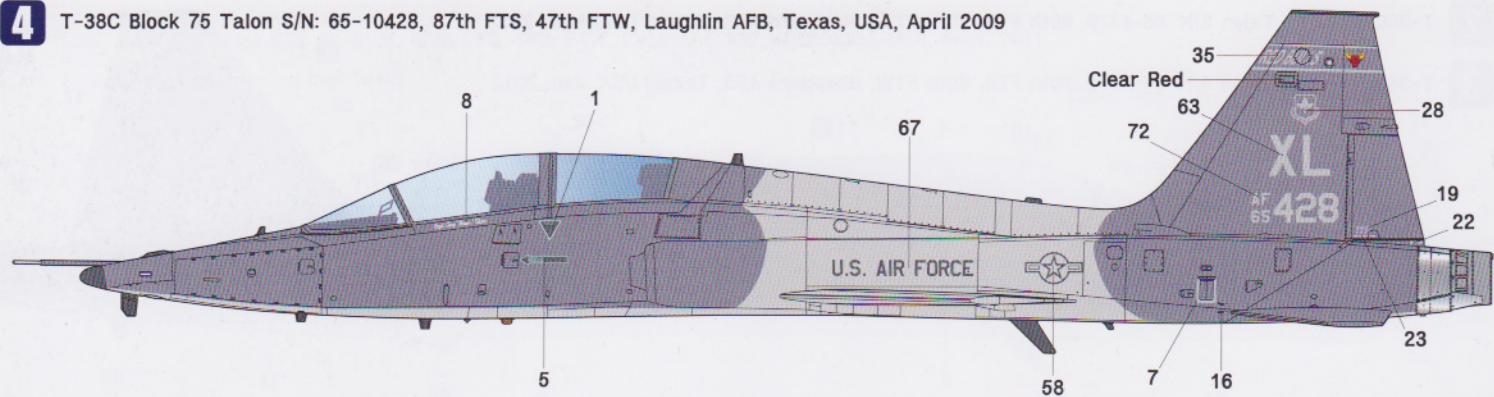

*Color number : GSI Creos Mr. Color.

C339	C73	MC214
FS16081	FS16473	Dark Iron
Engine Grey	Air Defence Grey	