

ACADEMY

HOBBY MODEL KITS

13213

MERKAVA Mk.IV

메르카바 Mk.IV

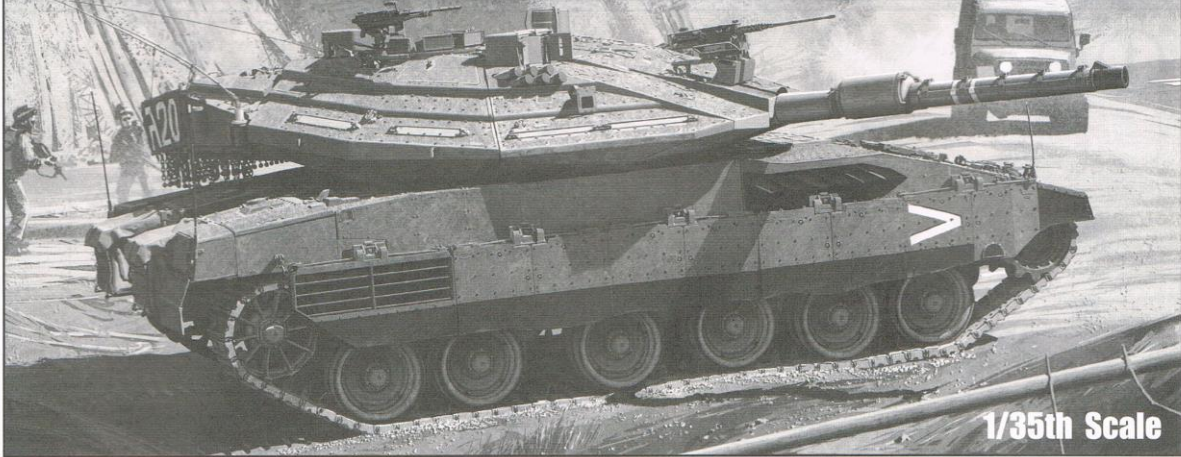

1/35th Scale

PHOTO-ETCHED PARTS ASSEMBLY

● Necessary tool for etching attachment

예정 부착에 필요한 도구

Instant glue(순간접착제)

Knife(커터칼)

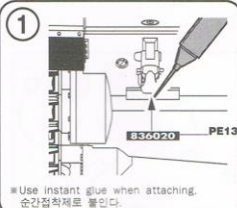

Use instant glue when attaching.
순간접착제로 붙인다.

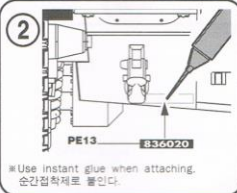

Use instant glue when attaching.
순간접착제로 붙인다.

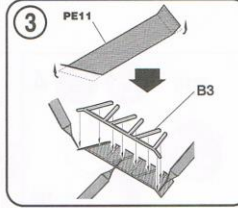

Use instant glue when attaching.
순간접착제로 붙인다.

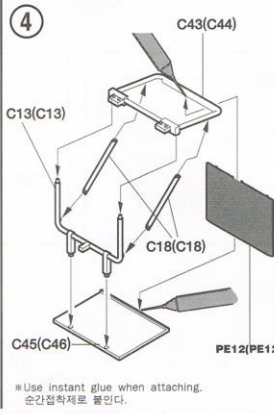
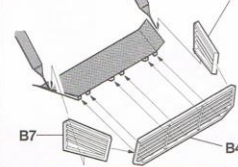

Use instant glue when attaching.
순간접착제로 붙인다.

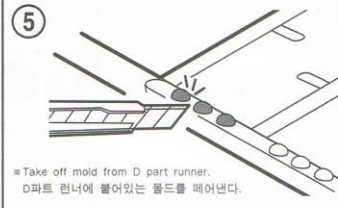

Take off mold from D part runner.
D파트 런너에 붙어있는 몰드를 떼어낸다.

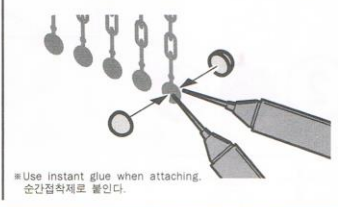

Use instant glue when attaching.
순간접착제로 붙인다.

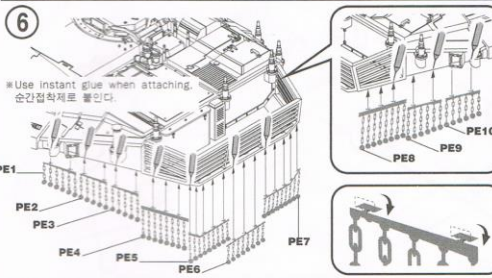

Use instant glue when attaching.
순간접착제로 붙인다.

No.	COLOR	GSI CREOS		LIFE COLOR	HUMBROL	MODEL MASTER		
		AGUEGUP	Mr. COLOR			ENAMEL	ACRYL	
1	FLAT BLACK	12	33	LC02	33	1749	4768	무광검정색
2	CLEAR BLUE	93	50				4658	블리어블루
3	STEEL	18	28	LC76	53	1780	4679	흑철색
4	OLIVE DRAB		304	UA003	155	1711	4728	올리브드람
5	GOLD	9	9	LC75	16	1744	4671	금색
6	TAN	27	44	UA015	148	1709	4722	탄
7	SINAI GRAY	70(70%) +340(30%)	80(70%) +340(30%)	UA119		2138	4814	시나이그레이
8	CLEAR RED	90	47		1321		4630	블리어레드
9	SILVER	8	8	LC74	11	1790	4678	은색

⚠️ 보호자 분들은 반드시 읽어 주십시오.

● 조립하기 전에 취급 설명서를 꼼꼼히 읽어 내용을 충분히 이해한 상태에서 조립하여 주십시오.
● 부품을 자를 때는 해당번호를 확인한 뒤 니퍼 등으로 깨끗이 잘라 주십시오. 칼을 이용하여 부품을 다룰 경우 손을 다치지 않도록 세심한 주의를 기울여 주십시오.
● 작은 부품 따위를 절대로 입에 넣지 마십시오. 잘못하여 삼킬 경우 질식 등의 위험이 있습니다. ● 자칫 먹을 우려가 있으므로 3세 미만의 어린이에게는 절대로 주지 마십시오.
● 잘라낸 부품은 깨끗이 다듬어 조립하고 남은 쓰레기는 분리하여 잘 버려 주십시오. ● 기능상 부득이하게 튀어나온 부분이 있을 수 있습니다. 취급 시 충분한 주의를 기울여 주십시오.
● 제품 및 부품이 포장된 비닐봉지는 개봉 후 즉시 어린이의 손에 닿지 않는 곳에 잘 버려 주십시오. 마리에 워칭이쓰거나 얼굴을 닿을 경우 질식의 위험이 있습니다.
● 색칠 및 접착을 위하여 모형용 도료 및 접착제 등을 사용할 때에는 창문을 열어 환기를 시키고 화기를 멀리하여 주십시오. 사용하고 남은 도료 및 접착제는 어린이의 손이 닿지 않는 곳에 잘 보관하여 주십시오.

● Before starting to assemble, read the instruction manual very carefully to understand well everything of the instructions.
● Before cutting a part off sprue, check the part number again and use proper tool such as nipper to cut it clearly. Take care not to be hurt in use of modelling knife to cut or trim parts.
● Never put small parts in the mouth to avoid any danger of suffocation by accidentally swallowed ones. ● Never let children less than 3 years old have it to avoid any danger of taking it.
● The product may have some protruding parts for functional reasons and take care of handling it always.
● After cutting a part off sprue, trim it clearly to assemble and the wastes should be properly sorted to dispose.
● Plastic bags packed with the product and parts should be disposed in a proper place immediately to keep out of children to avoid any danger of suffocation by pulling it over head or putting it over face.
● Before using modelling colors or cement, open windows to keep the room well ventilated and do not use near fire or flame. After using them, keep in a proper place out of children.

주의
WARNING!

점착한다 Cement parts Coller Kleben Pegar Incollare Colar Kleven	점착하지 않는다 Do not cement Ne pas coller Nicht kleben No pegar Non incollare Nao colar Niet kleven	3 중반을 중립한다 Repeat operation Répéter l'opération Vorgang wiederholen Repetir la operación Repitire Repitir a operação Herhalen	☆ 전사지를 붙인다. Decals Décalcomanies Abziehbild	9 무게추를 넣는다. Add weight Lester Gewicht	☐ 구멍이나 홈을 메워준다. Use filler Mastiquer Schließen
잘라낸다 Cut away Couper Schneiden Cortar Tagliare Cortar Snijden	? 선택한다. Optional parts Choix Auswahlmöglichkeit Election Scelta Opção Wahl	◀▶ 반대측도 포함한다. Repeat for opposite side Répétition de la page Wiederholung für gegenüberliegende Seite	☐ 구멍을 뚫어준다. Make hole Faire un trou Öffnen	! 주의한다. Be careful Faire attention Hier Vorsicht	☐ 색칠 및 전사지 붙이기 번호 Painting scheme number Numeros de la liste de peintures Lackierschemanummer

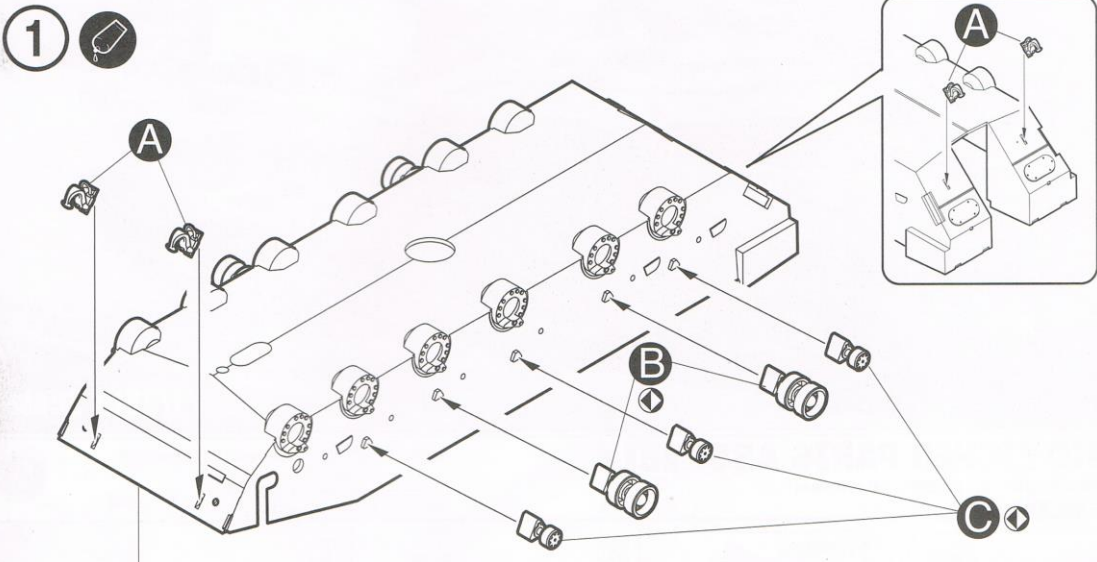

Lower Hull/하체

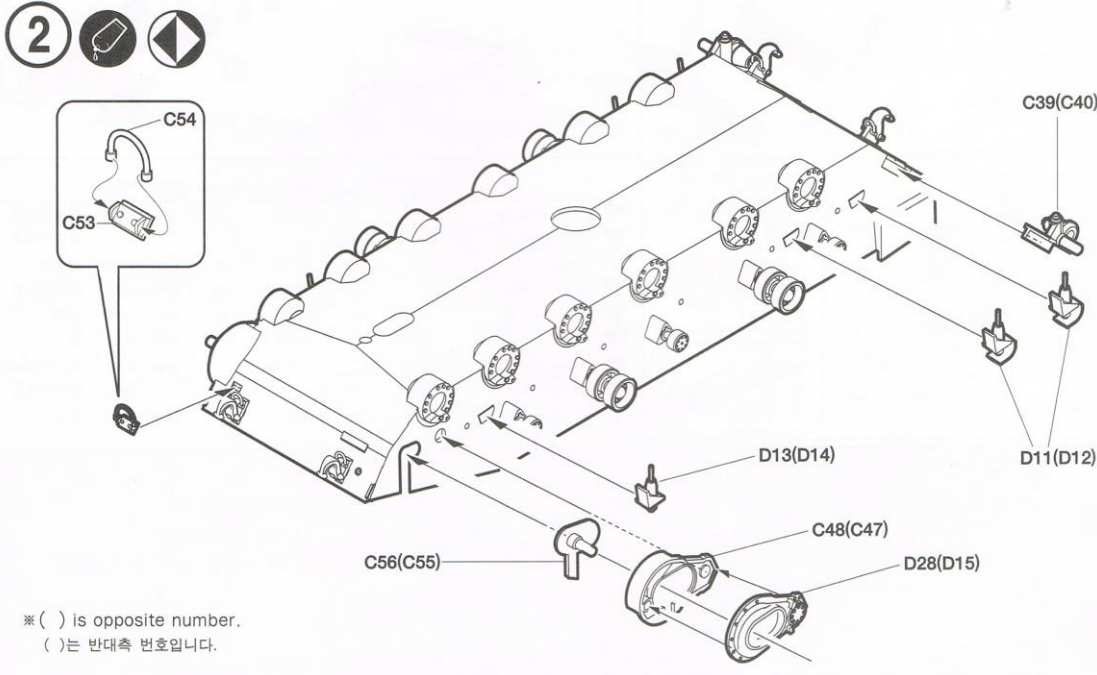
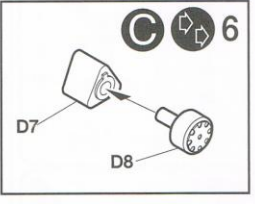
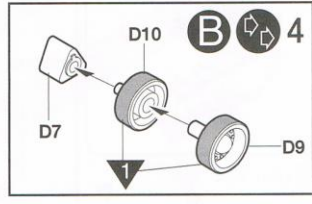
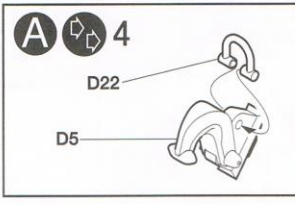

※ () is opposite number.
()는 반대측 번호입니다.

3

※ () is opposite number.
()는 반대측 번호입니다.

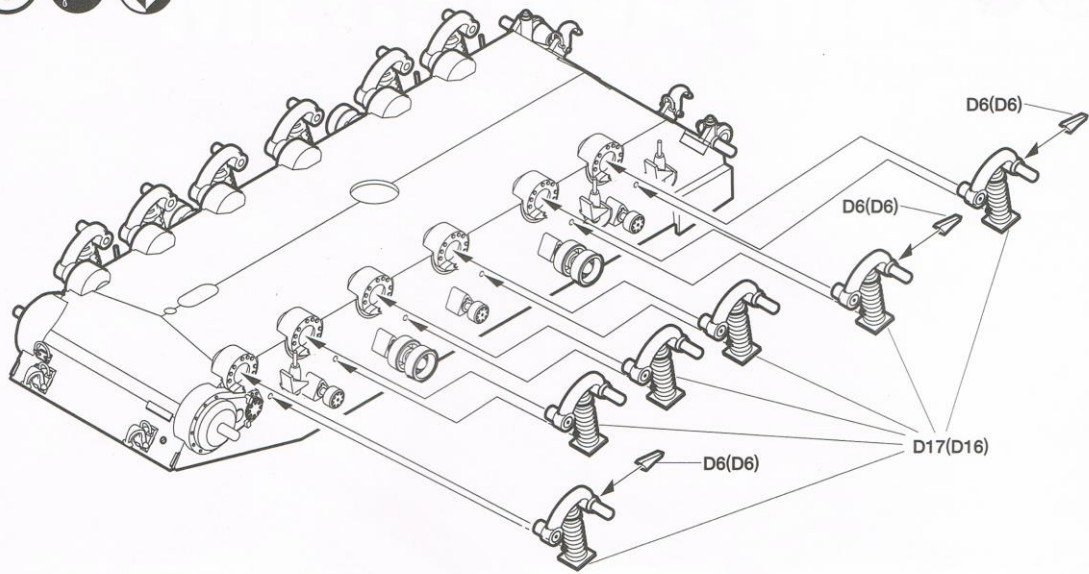

4

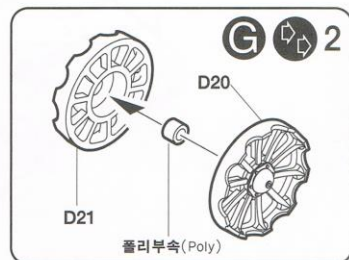
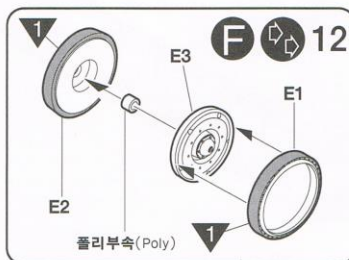
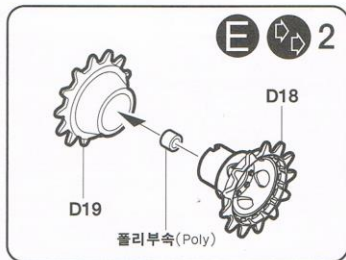
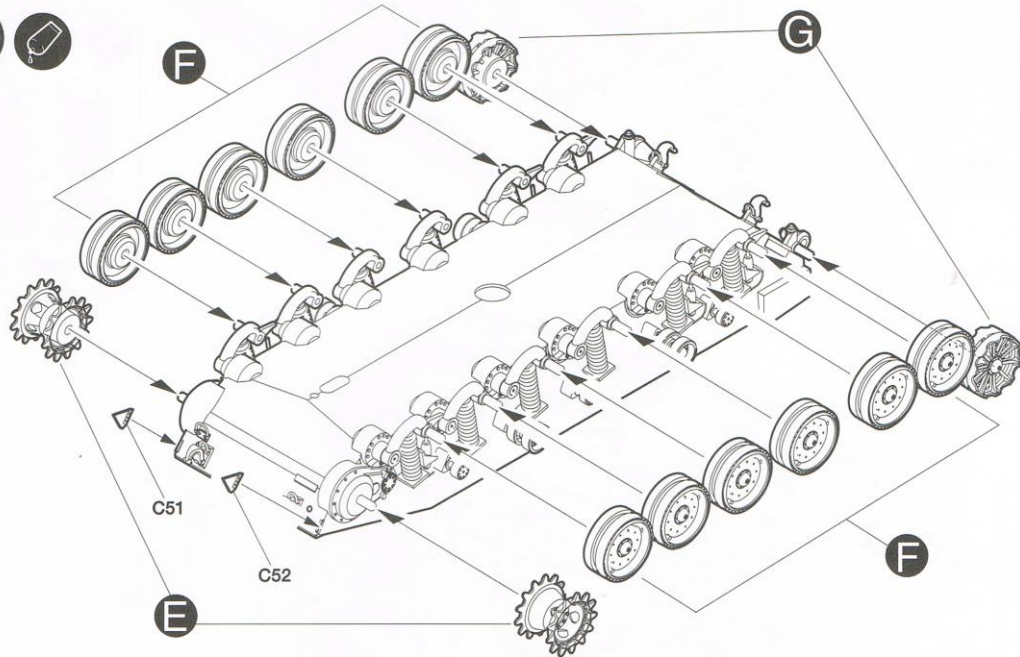

5  

※ () is opposite number.
()는 반대측 번호입니다.

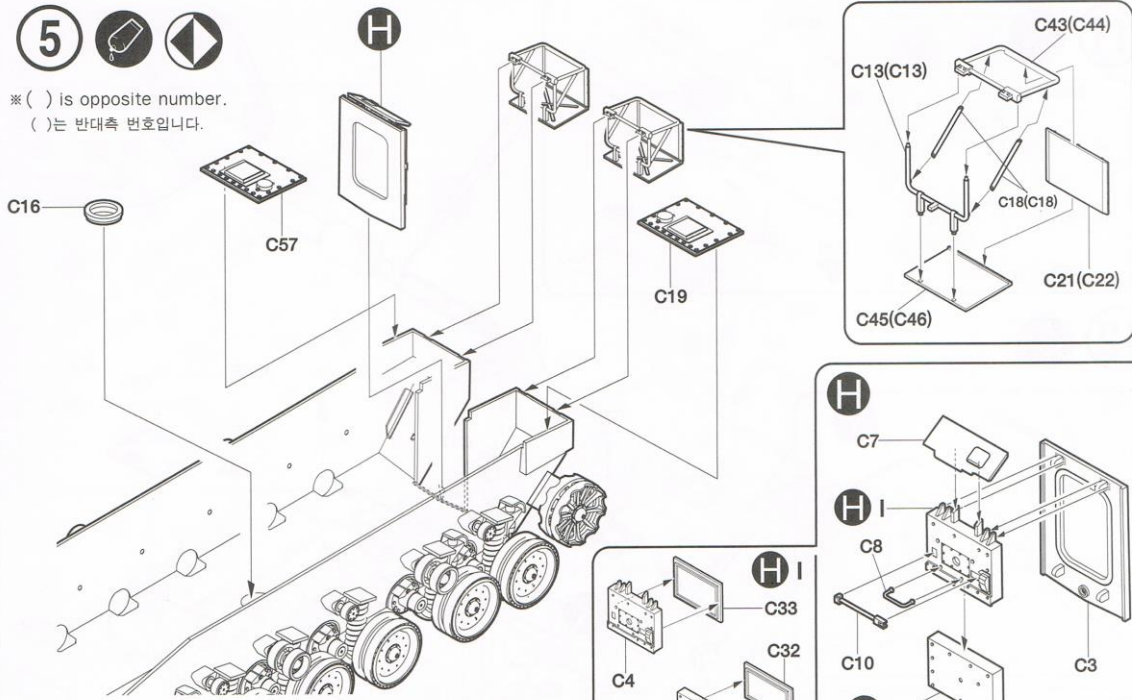

6 

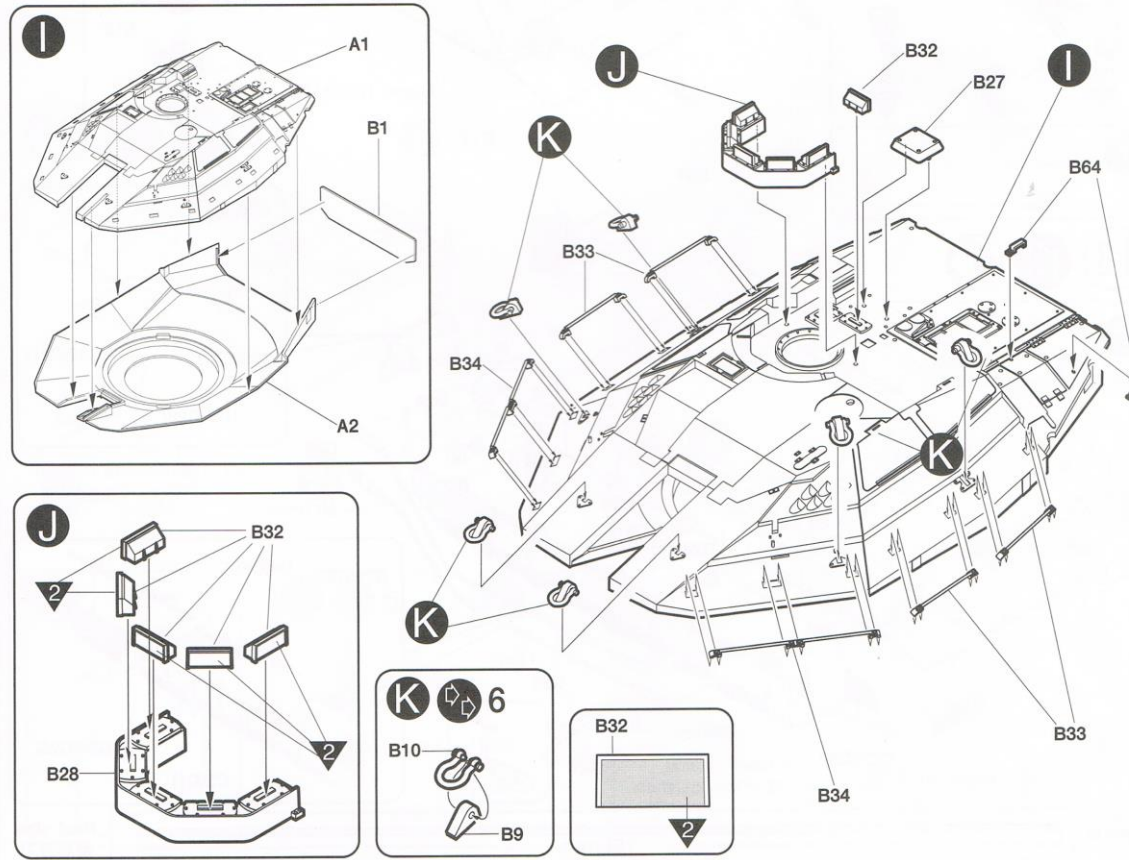

7

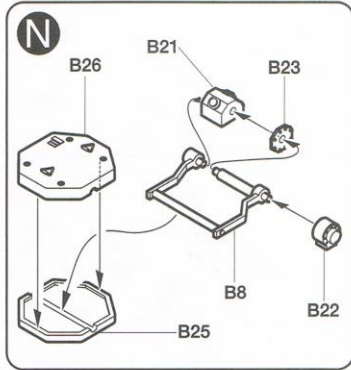
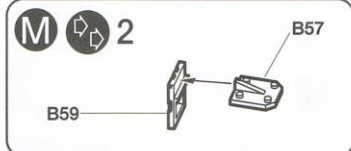
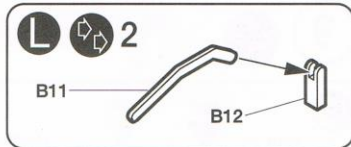
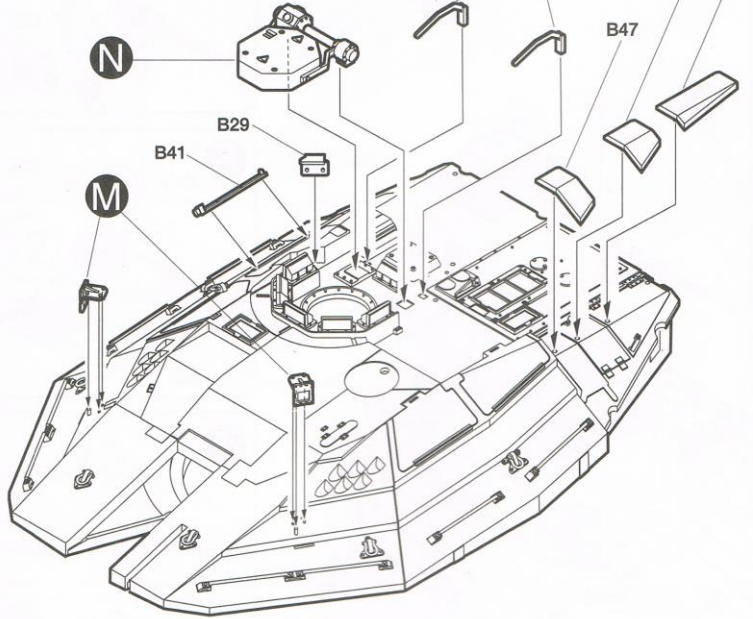

8

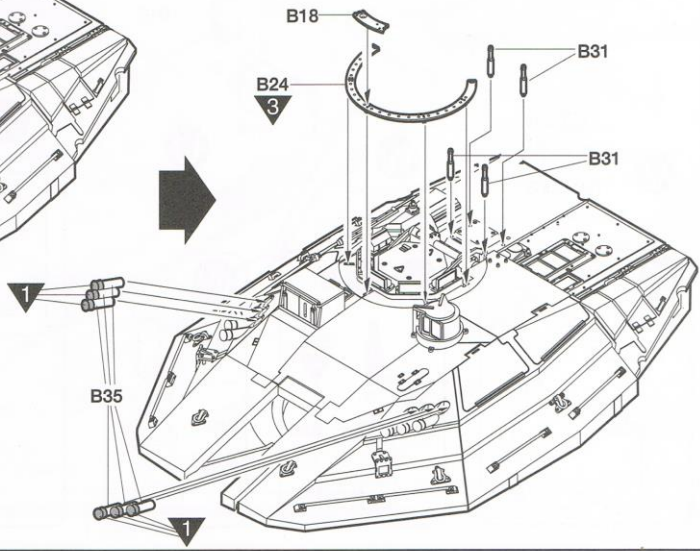
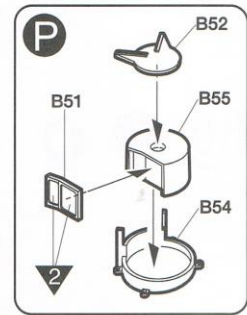
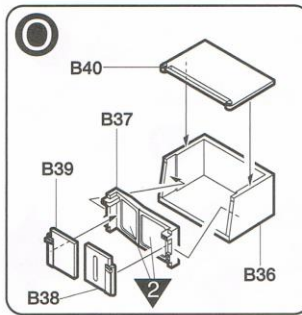
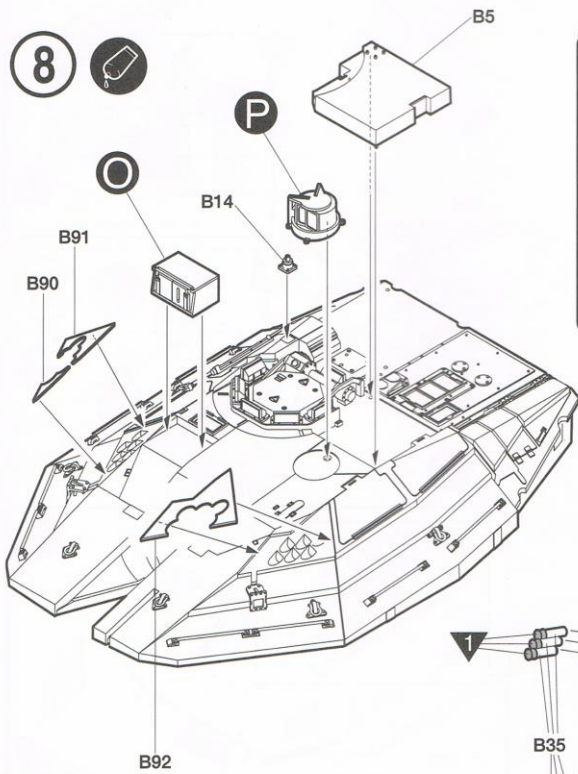

9

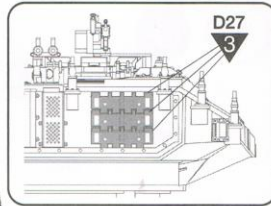
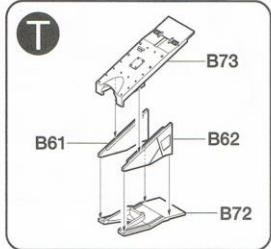
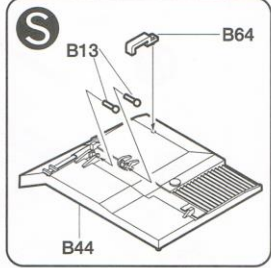
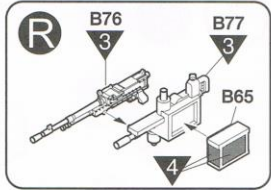
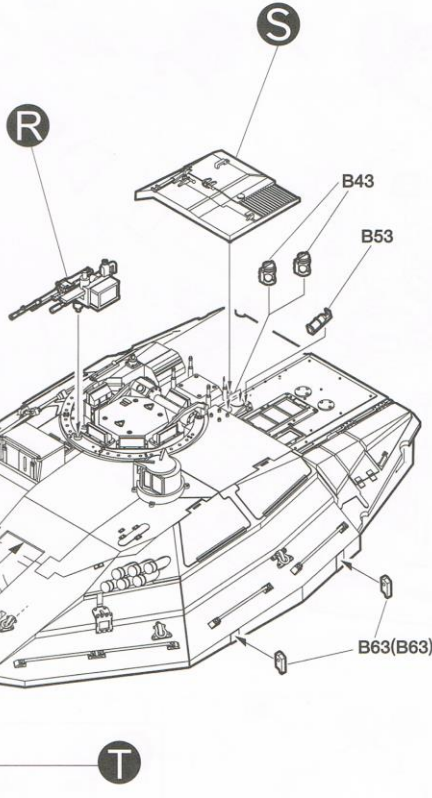
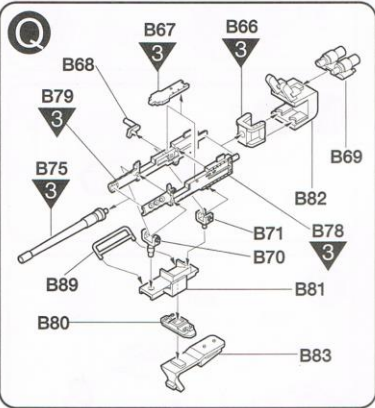

10

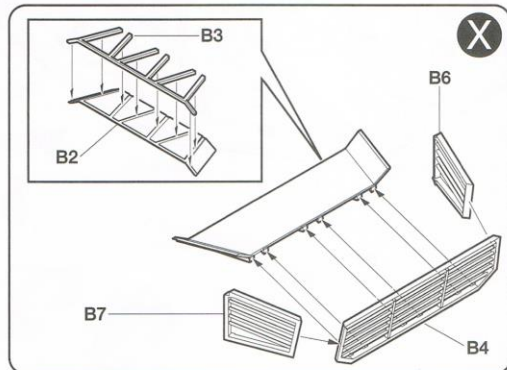
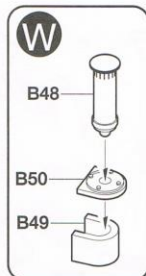
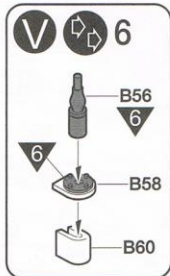
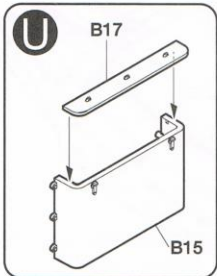
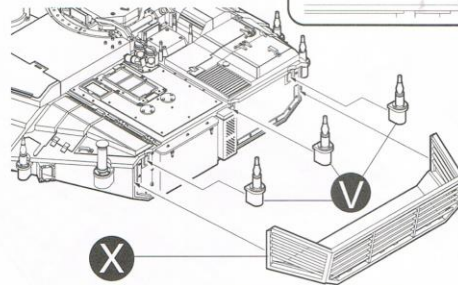
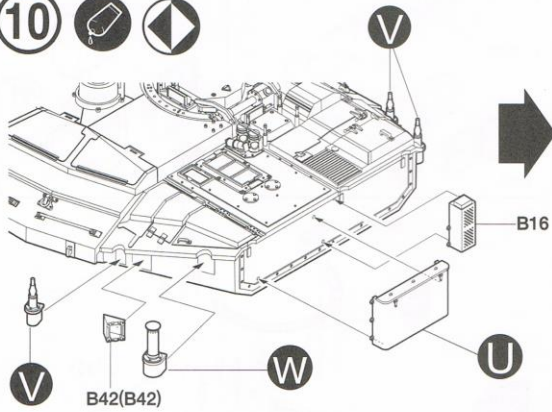

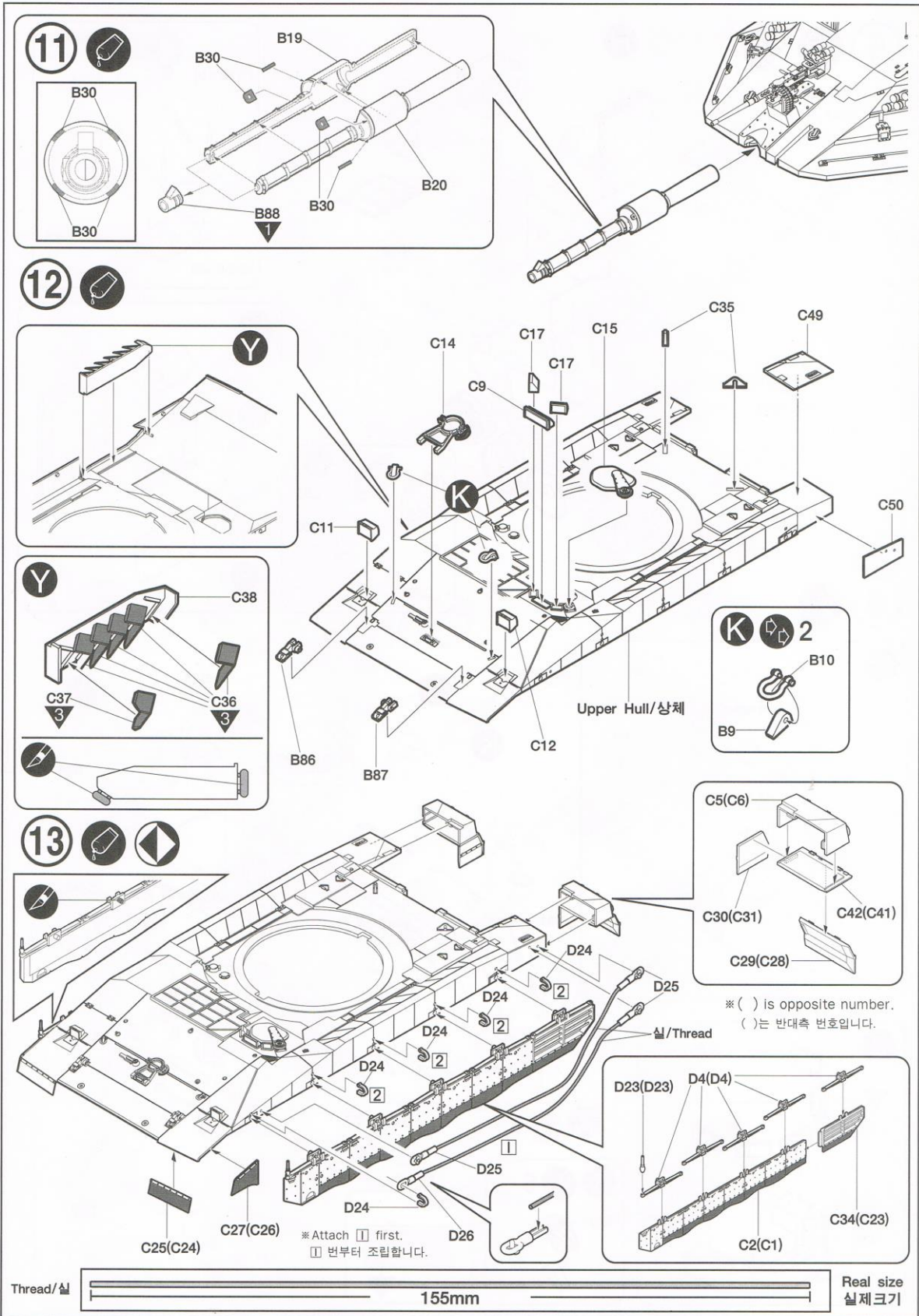

14 

※ Attach **I** first.
I 번부터 조립합니다.

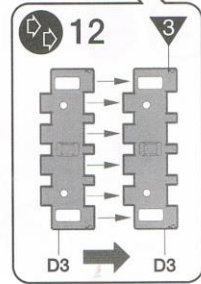
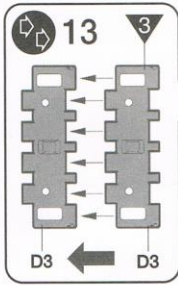
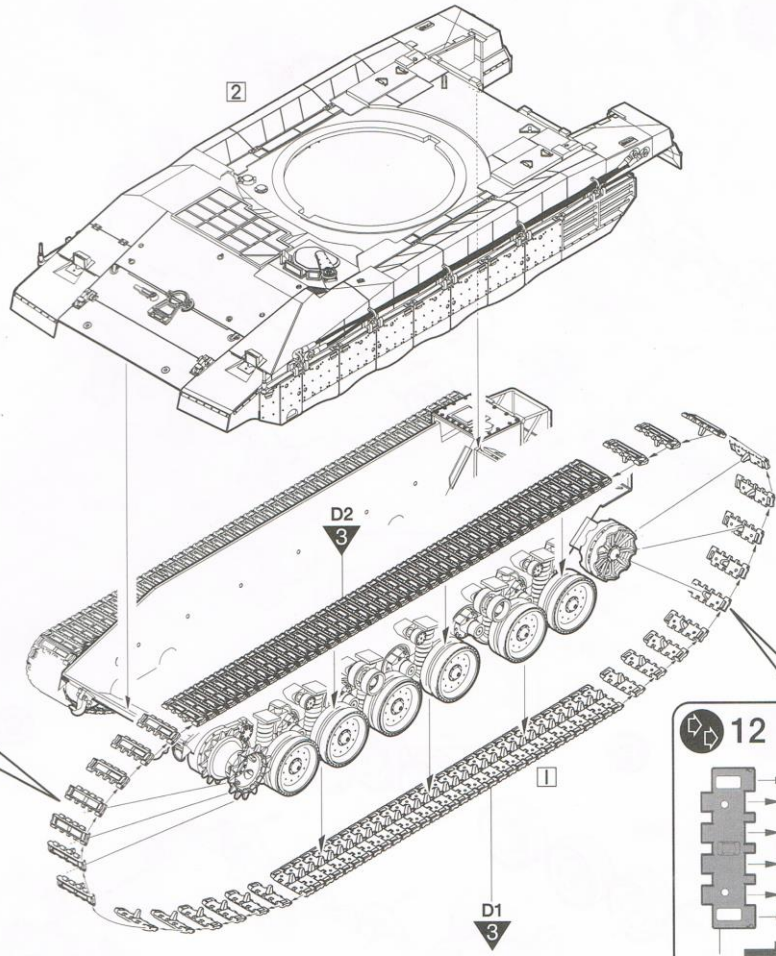

15 

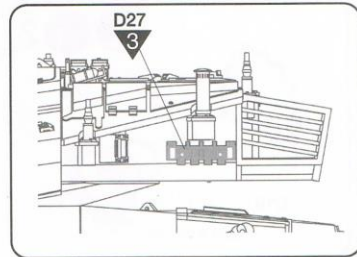
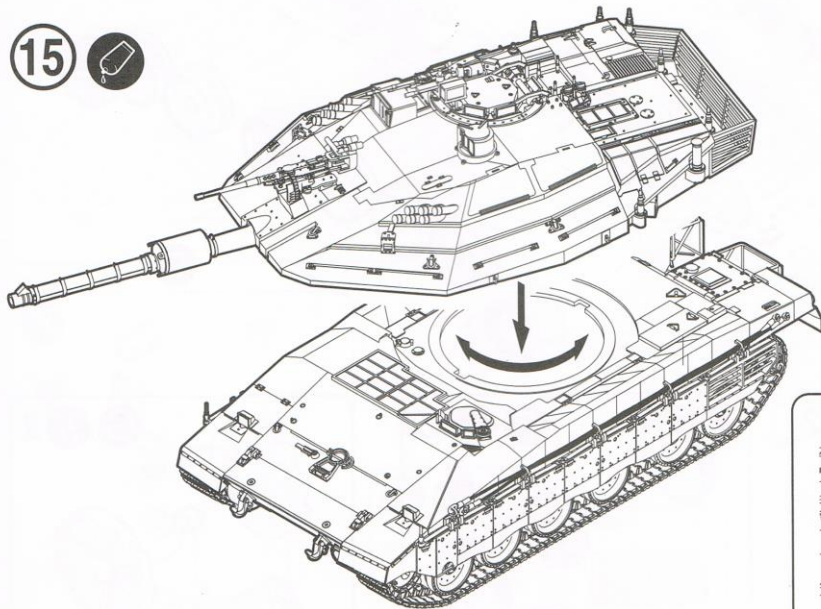

ACADEMY

HOBBY MODEL KITS

MERKAVA Mk-IV

13213

1/35th Scale

Painting & Decal placement 색칠 및 전사지 붙이기

Body Color 차체색

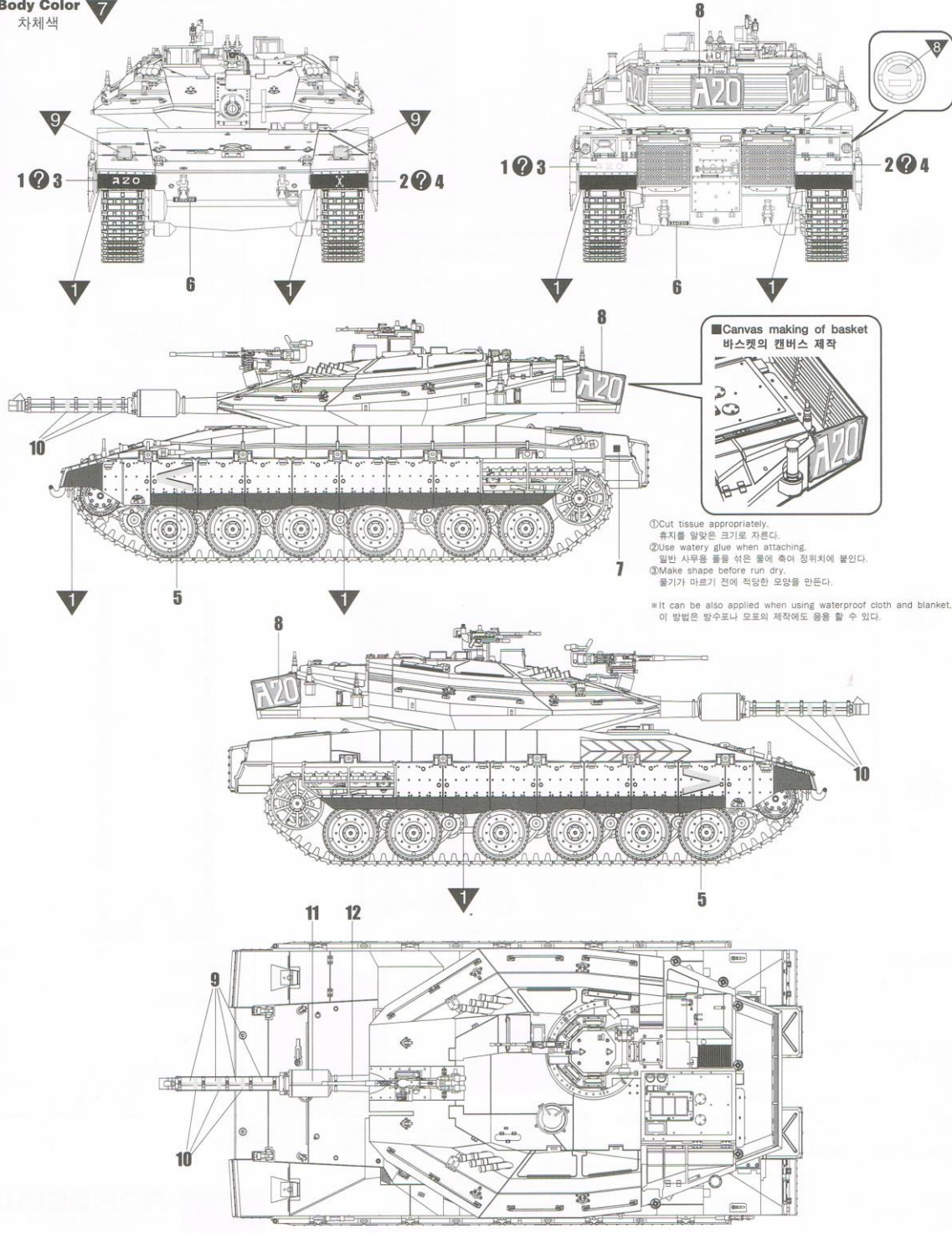

Parts Locating Diagram 부품도

A

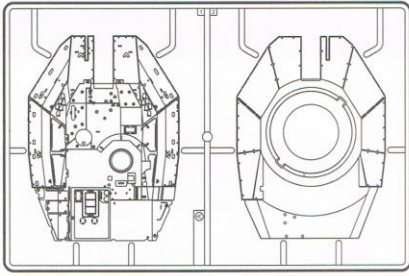

C

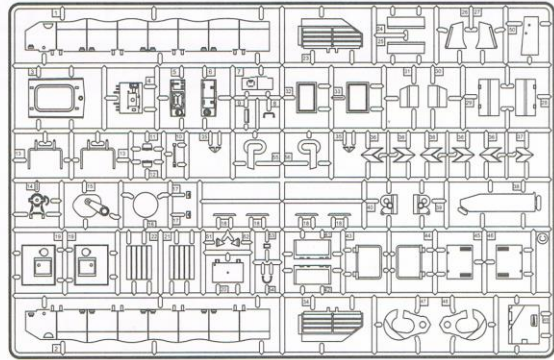

B

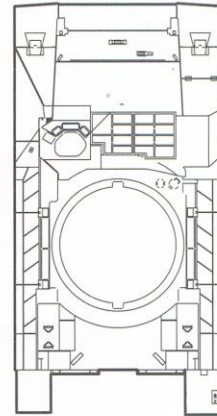
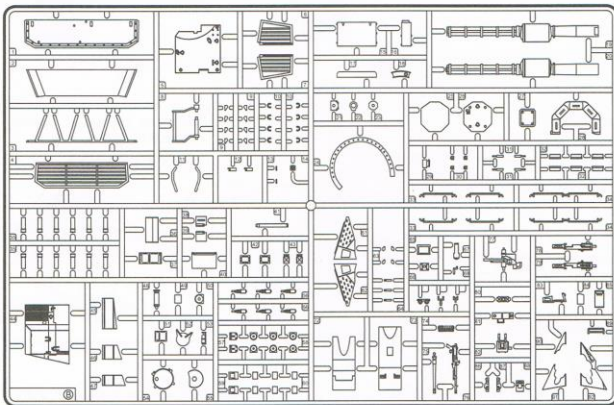

D

x2

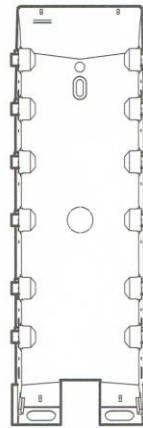
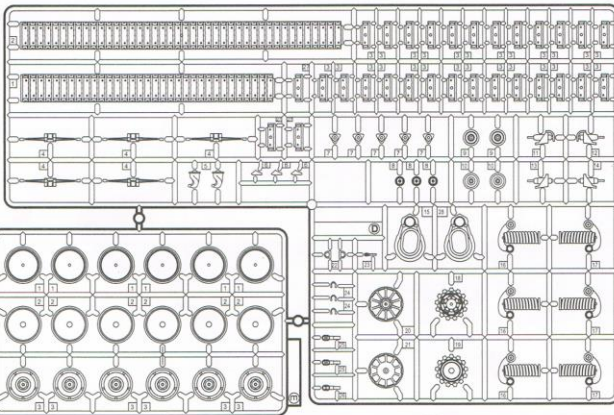

E

x2

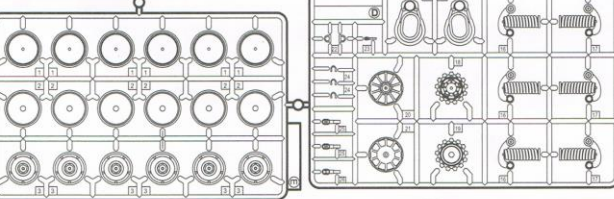

<READ THIS BEFORE YOU BEGIN>

- Study the instructions before assembling.
- Do not use too much cement to join parts.
- Open a window or make area well ventilated when cement or paint is in use.
- Check the fit of each piece before cementing into place.
- Never use cement or paint near open flame.
- Tear up and throw away the empty plastic bags to avoid danger of suffocation for little children.

<ALLGEMEINE HINWEISE>

- Die Anordnung der Bauteile ist aus den Zeichnungen der Anleitung ersichtlich.
- Die Teile vor dem Verkleben ungleichmässig zusammenhalten, um ihren paßstz zu prüfen.
- Klebstoff nicht zu dick auftragen.
- Klebstoff und Farben niemals in der Nähe einer Flamme verwenden.
- Während der Bemalung mit Spritzpistole oder Pinsel für frische Luftzufuhr, z.B. öffnen des Fensters, sorgen.
- Bausatz von kleinen Kindern fernhalten. Verhüten Sie, daß Kinder irgendwelche Bauteile in den Mund nehmen oder Plastiktüten über den Kopf ziehen.

<LISEZ CE QUI SUIT AVANT DE COMMENCER LE MONTAGE>

- Etudier les schémas d'assemblage.
- Contrôler que chaque pièce soit bien conforme avant de la coller à sa place.
- N'utilisez pas trop de colle pour réunir les pièces.
- Ne faites jamais manipuler la colle ou peinture à proximité d'une flamme.
- Aérer soigneusement la pièce où vous peignez/ouvrez la fenêtre).
- Après avoir sorti les pièces du sac en plastique, déchirer le sac afin d'éviter que les enfants ne le mettent sur la tête et ne s'étouffent.



<組み立てる前に>

- 組み立てる前に説明書をお読み下さい。 - 部品をランナーから切りはなす際は模型用ニッパーとカッターを使用します。
- 接着剤をふしなめくることが正しい仕上げです。 - 組み立て後の部屋やテーブル周辺小さな子供の手の届かない安全な所に保管して下さい。
- 接着剤や塗料を使用する時はときどき窓を開けて換気につけてまじょう。 - 接着する前に部品を合わせて確かめます。

■조립하기 전에

- 부품을 조립하기 전에 설명서를 잘 읽어본 후 조립한다.
- 접착제나 기타 부품을 앞에서 확인 후 조립한다.
- 부품을 자를 때는 칼이나 니퍼로 자르거나 잘라낸다.
- 이러니를 확인해나 접착제를 사용할 때는 창문을 열어 환기를 시키고 화기를 멀리한다.
- 접착제를 사용할 곳과 사용하지 않는 곳을 주의하고 너무 많이 바르지 않도록 한다.
- 사용 후 남은 부품은 어린 아이들의 손이 닿지 않도록 잘 처리한다.

●Photo Etched(에칭)

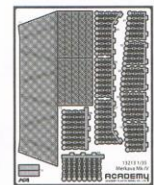

●Decal(전사지)

●Poly(폴리부속)

●Thread(실)

- Unused Parts(불필요 부품)
D3 x2, D13 x1, D14 x1, D15 x1, D24 x1
D25 x1, D26 x1, D27 x2, D28 x1

ACADEMY
HOBBY MODEL KITS

ACADEMY
ACADEMY PLASTIC MODEL CO., LTD.
273-64, Suyu-dong, Kangbuk-gu, Seoul, Korea
TEL:82-2-908-7000 FAX:82-2-997-3003