

35 K27

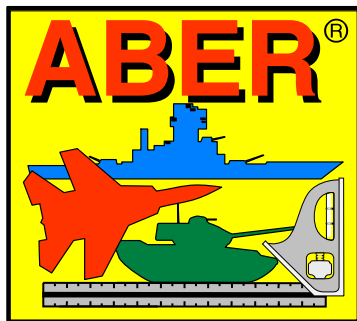

**EXCLUSIVE
EDITION**

**UPGRADE SET
FOR TAMIYA
1/35 MODEL**

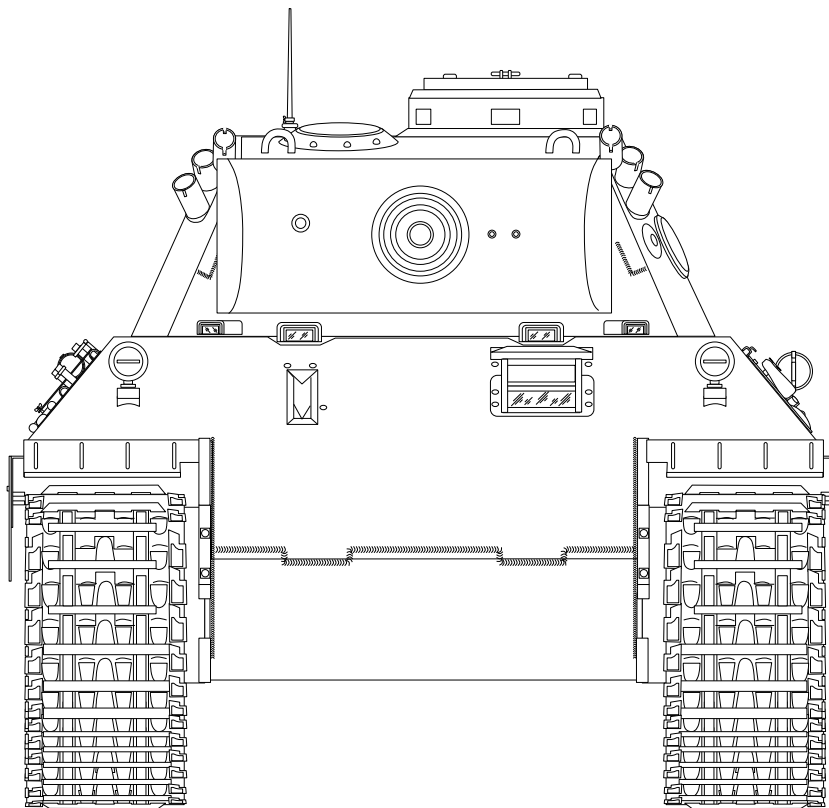

***Pz.Kpfw. V, Panther,
(Sd.Kfz. 171) - Ausf.D***

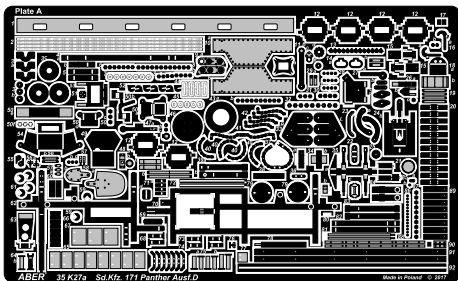
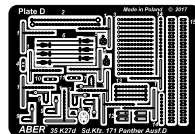
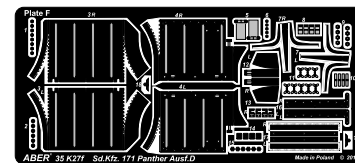
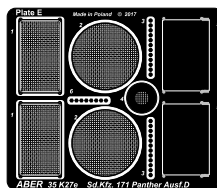
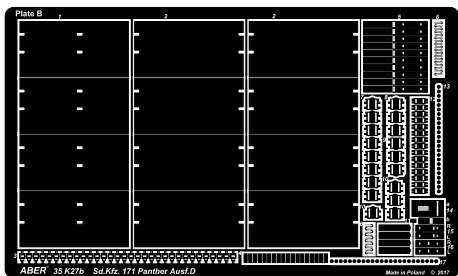
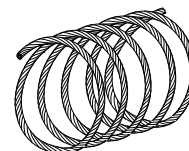
A**D****F****E****B****Bag with cable, wires & wood chock**

Ø 1,0 mm



Ø 0,2 mm



Ø 0,3 mm



Ø 0,4 mm

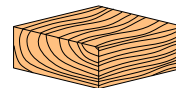
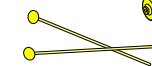
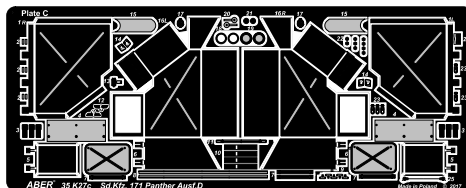

Ø 0,6 mm

**Turned parts****A x 6****Bag with muzzle brake parts****C****Bag with barrels, antennas, tubes and rods**

Tank MG34

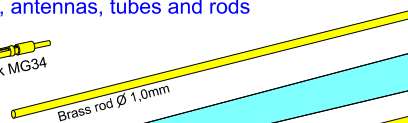

Brass rod Ø 1,0mm

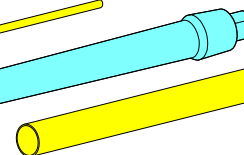
brass tube
Ø 1,0 mmbrass tube
Ø 5,00x57,00

Antenna 2 m

MOST IMPORTANT BIBLIGRAPHY:

- 1) PANTHER vol.3,4,5 - Waldemar Trojca - "Tank Power" AJ-Press ©1999
- 2) Achtung Panzer No.4 - PANTHER, Jagdpanther & Brummbär by Mitsuru Bitoh - Dai Nippon Kaiga Co.,Ltd. ©1994
- 3) GROUND POWER No.024, 079 - Delta Publishing Co.,Ltd. ©1996, ©2000
- 4) Militärfahrzeuge Band 9; Der Panzer-Kampfwagen Panther und Seine Abarten - Walter J. Spielberger - Motorbuch ©1994
- 5) Panther in Detail - B. Culver & U. Feist - Ryton Publications ©1998
- 6) Panzers in Saumur No.2 - Dai Nippon Kaiga Co.,Ltd. ©1990
- 7) New Vanguard 22: PANTHER VARIANTS 1942-1945 - Osprey Military ©1997
- 8) Panzer Tracts No.5-1 Panzerkampfwagen "Panther" Ausfuehrung D - Thomas L. Jentz and Hilary Louis Doyle

Thank you for purchase our set 35 **K27**
Read carefully this instruction. Scour metal parts before using
We advise that better method to join metal to metal parts is soldering.
Cement metal parts to plastic with good cyanoacryl or epoxy glue.

WARNING

Any unauthorized copying, producing and reproducing of ABER company products, or any part thereof, is strictly prohibited and any such action establishes liability for a civil action and may give rise to criminal prosecution.

Please note that, for purpose of improvement ABER sets designs are subjects to change without notice.

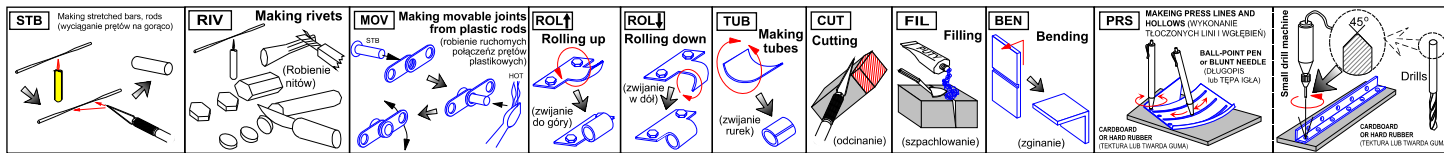

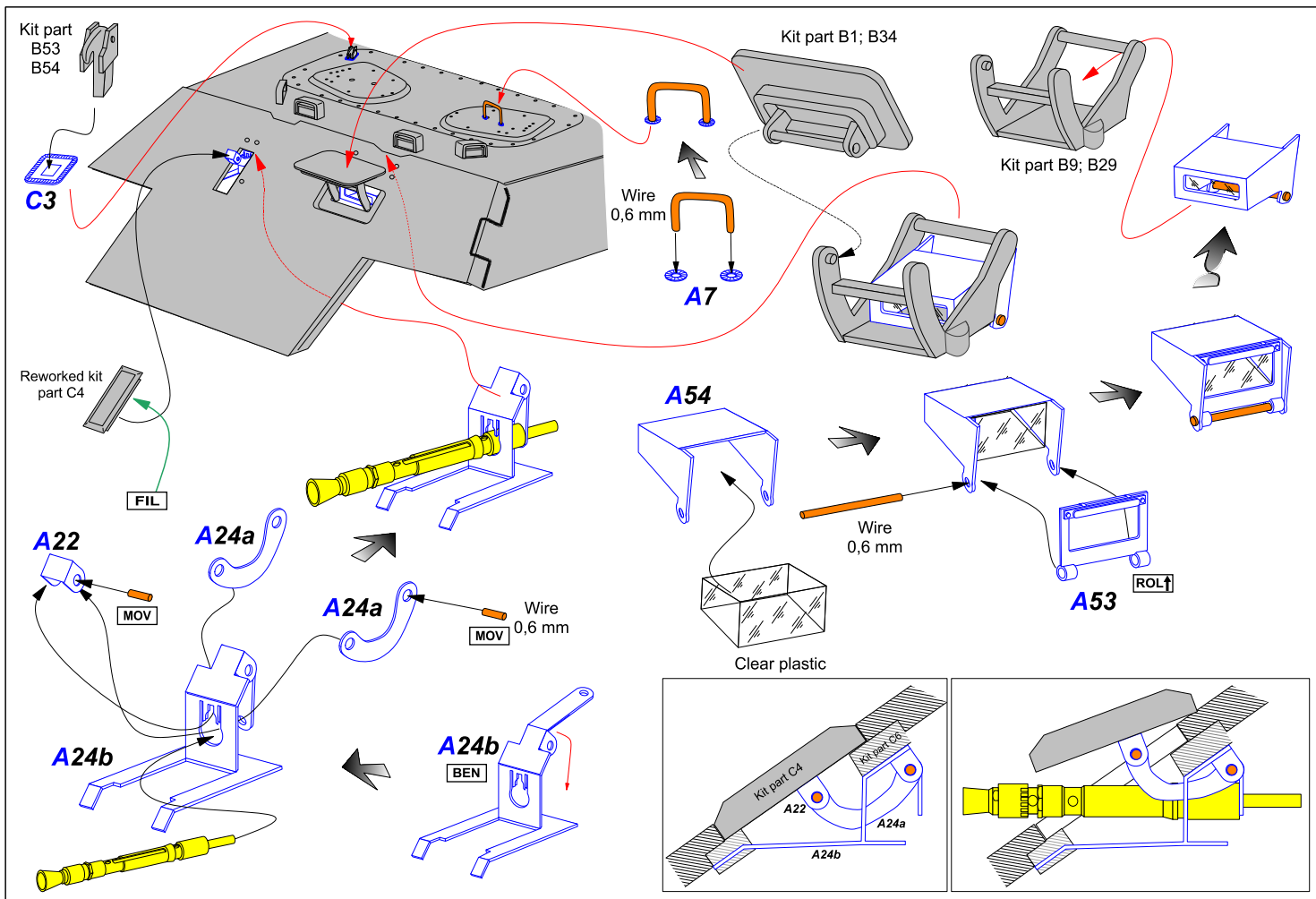

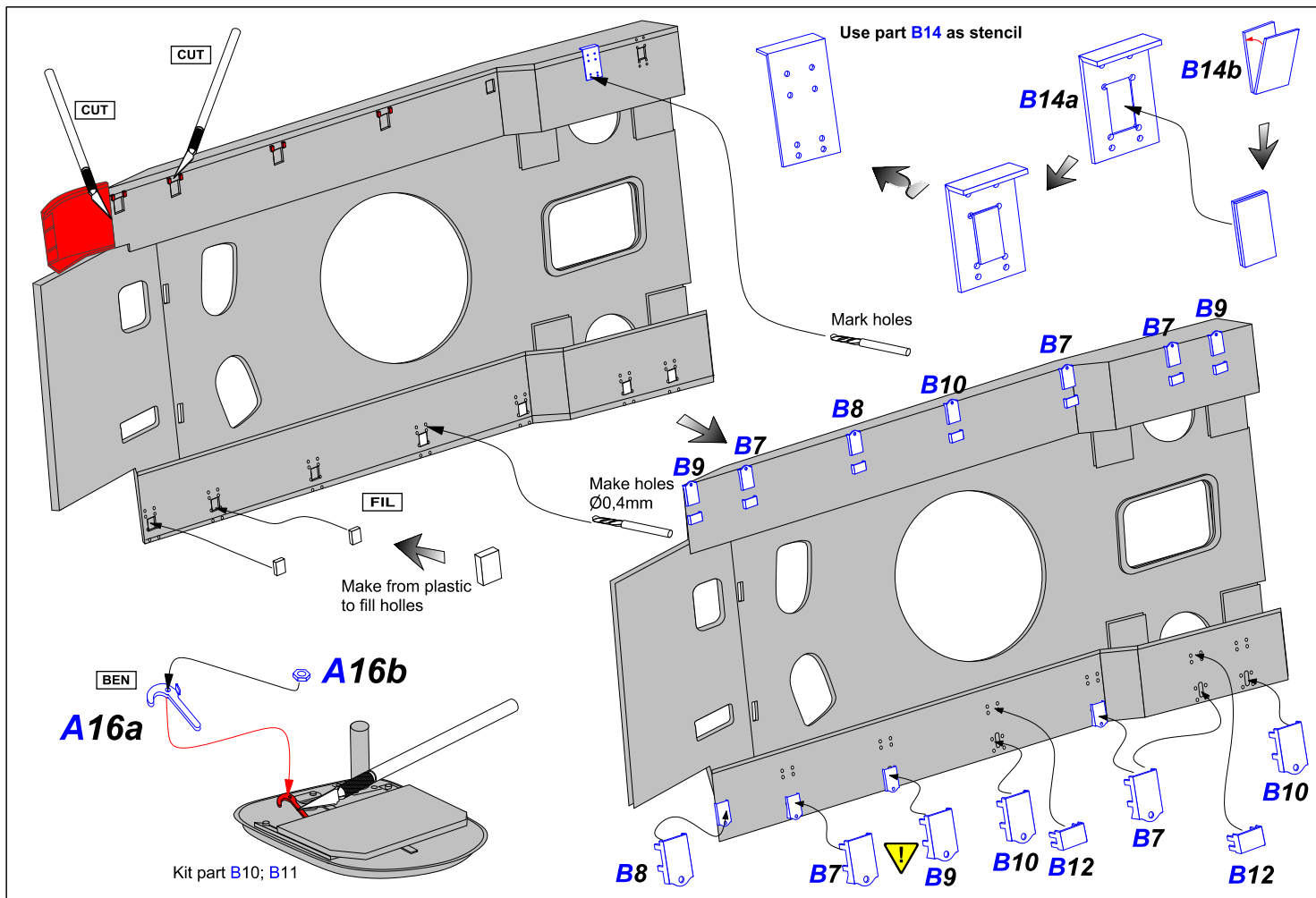

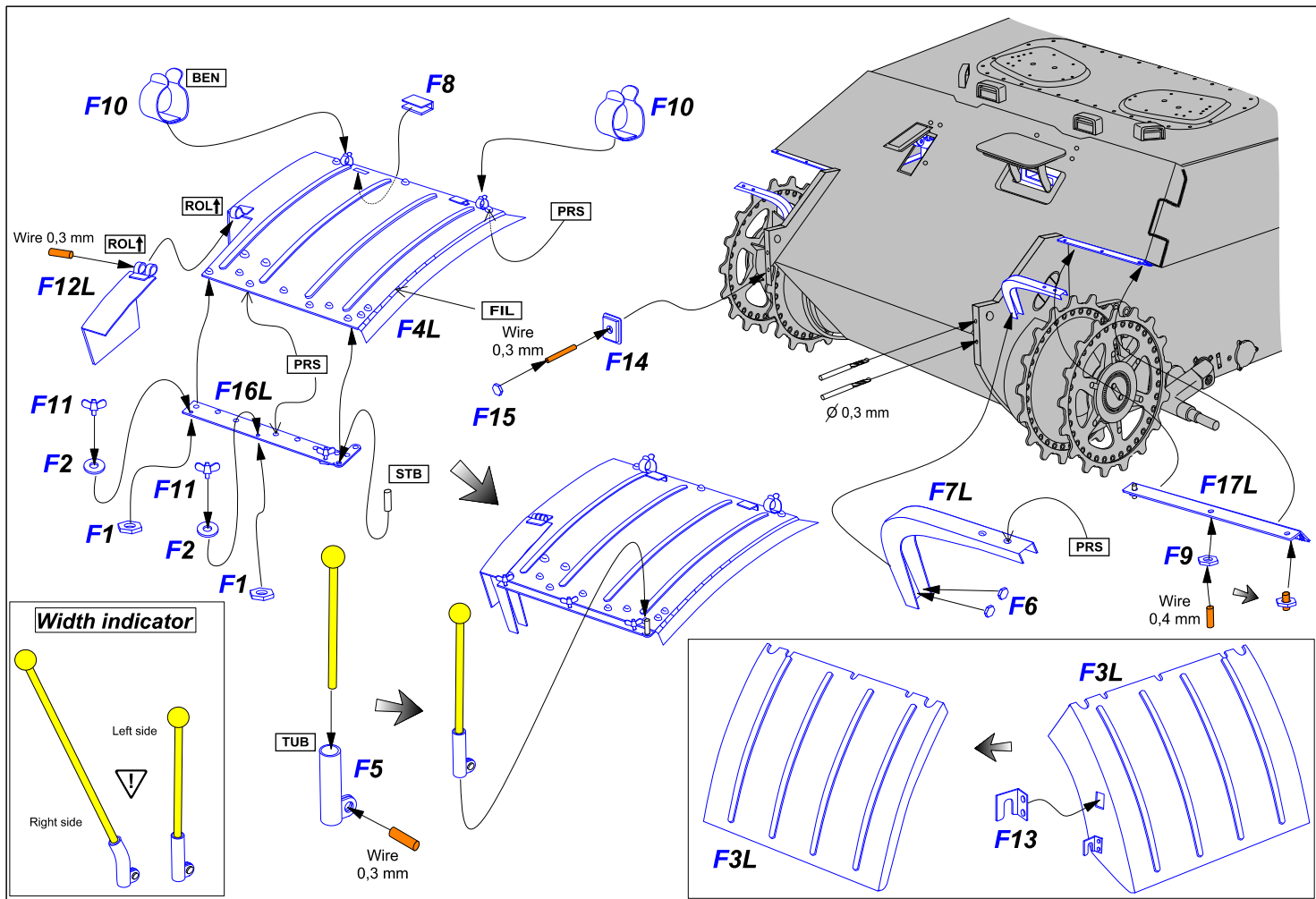

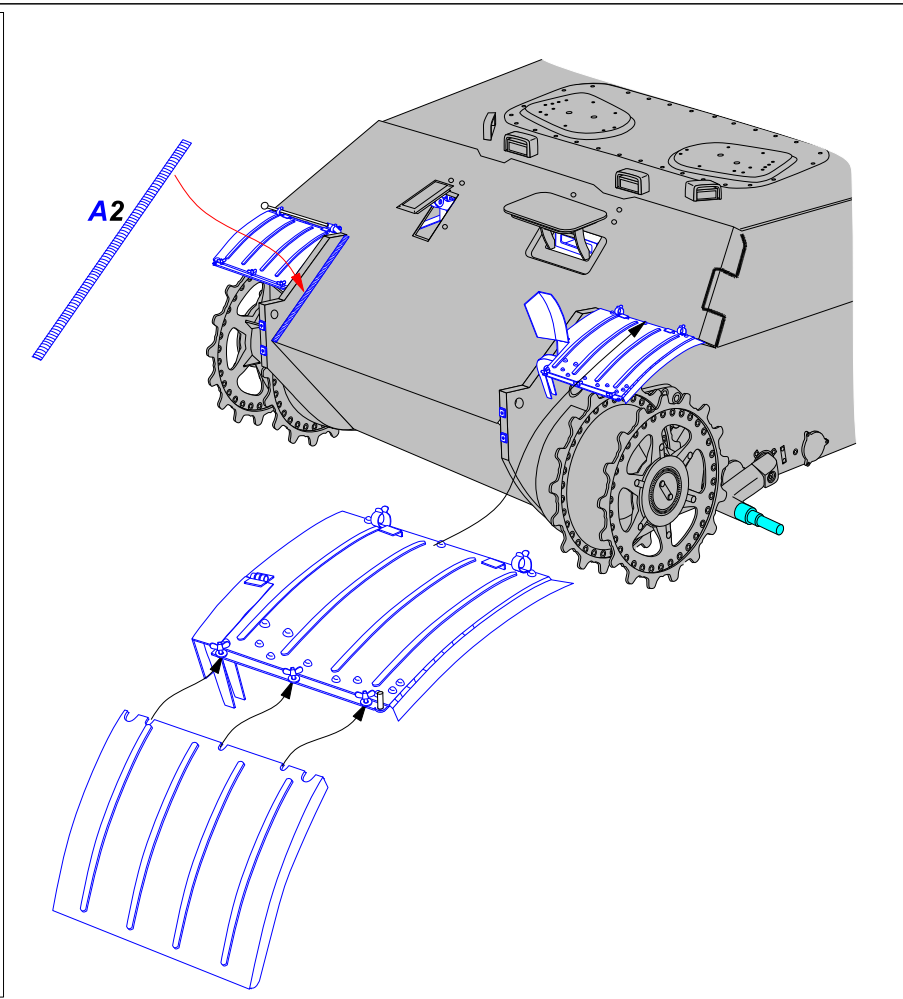
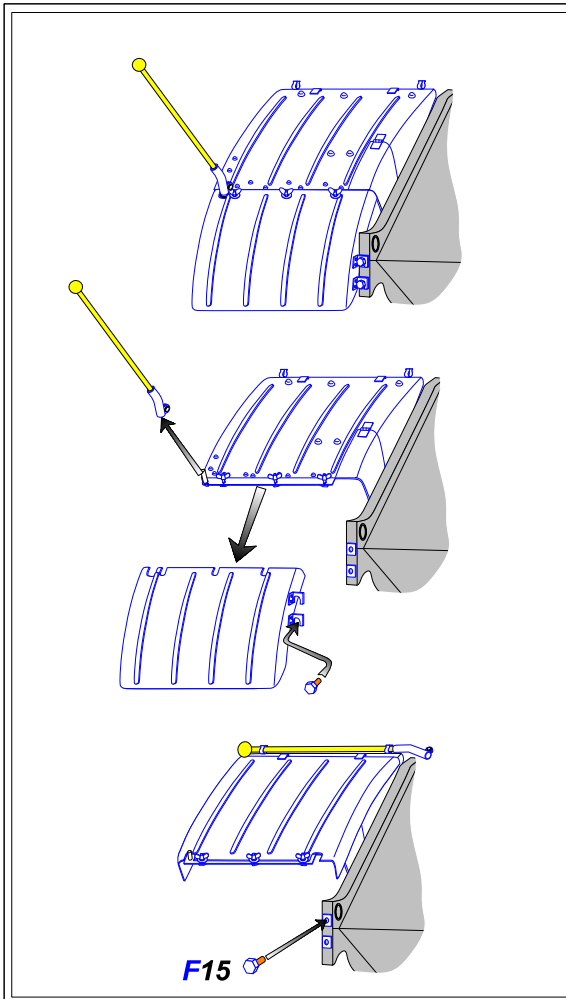

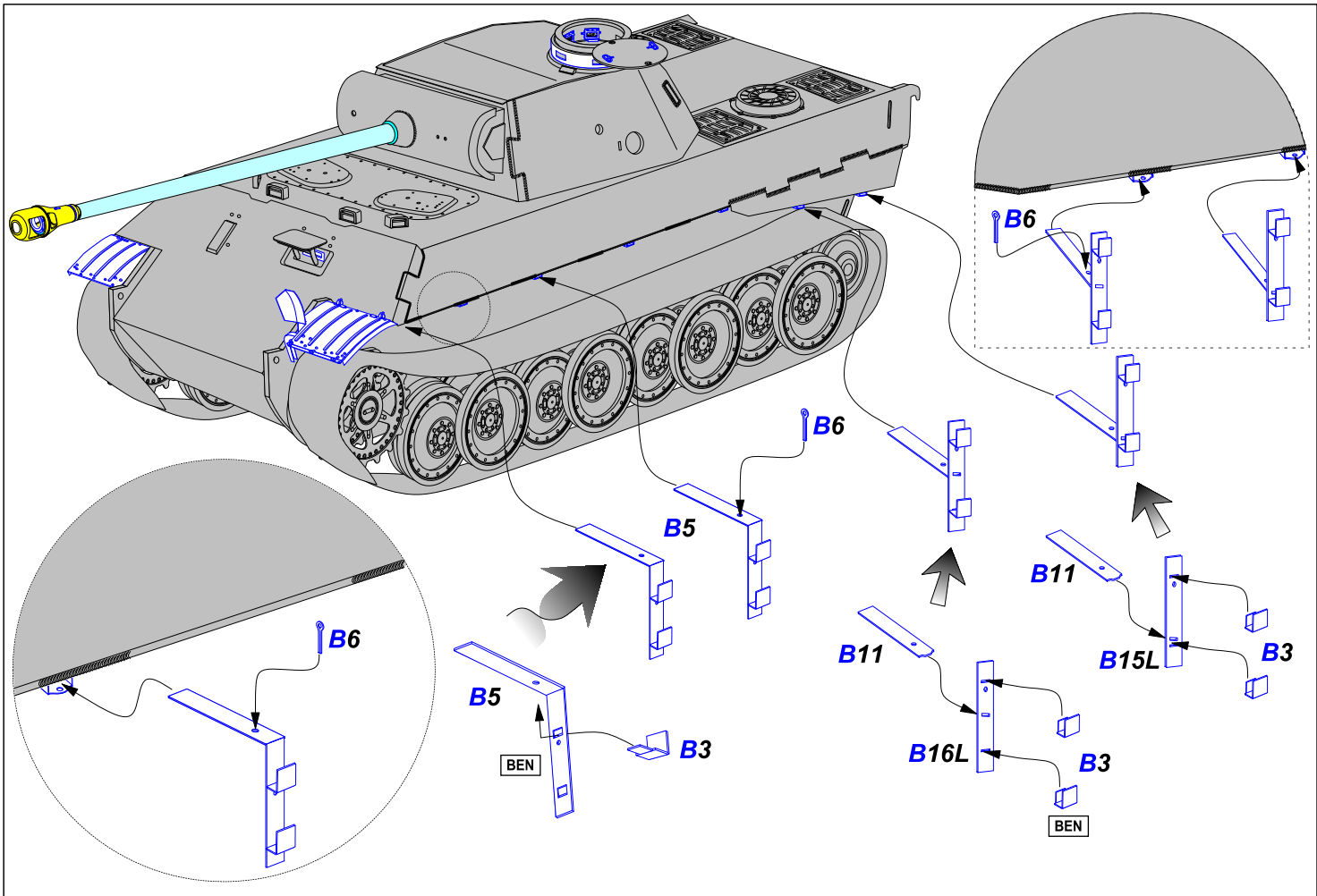

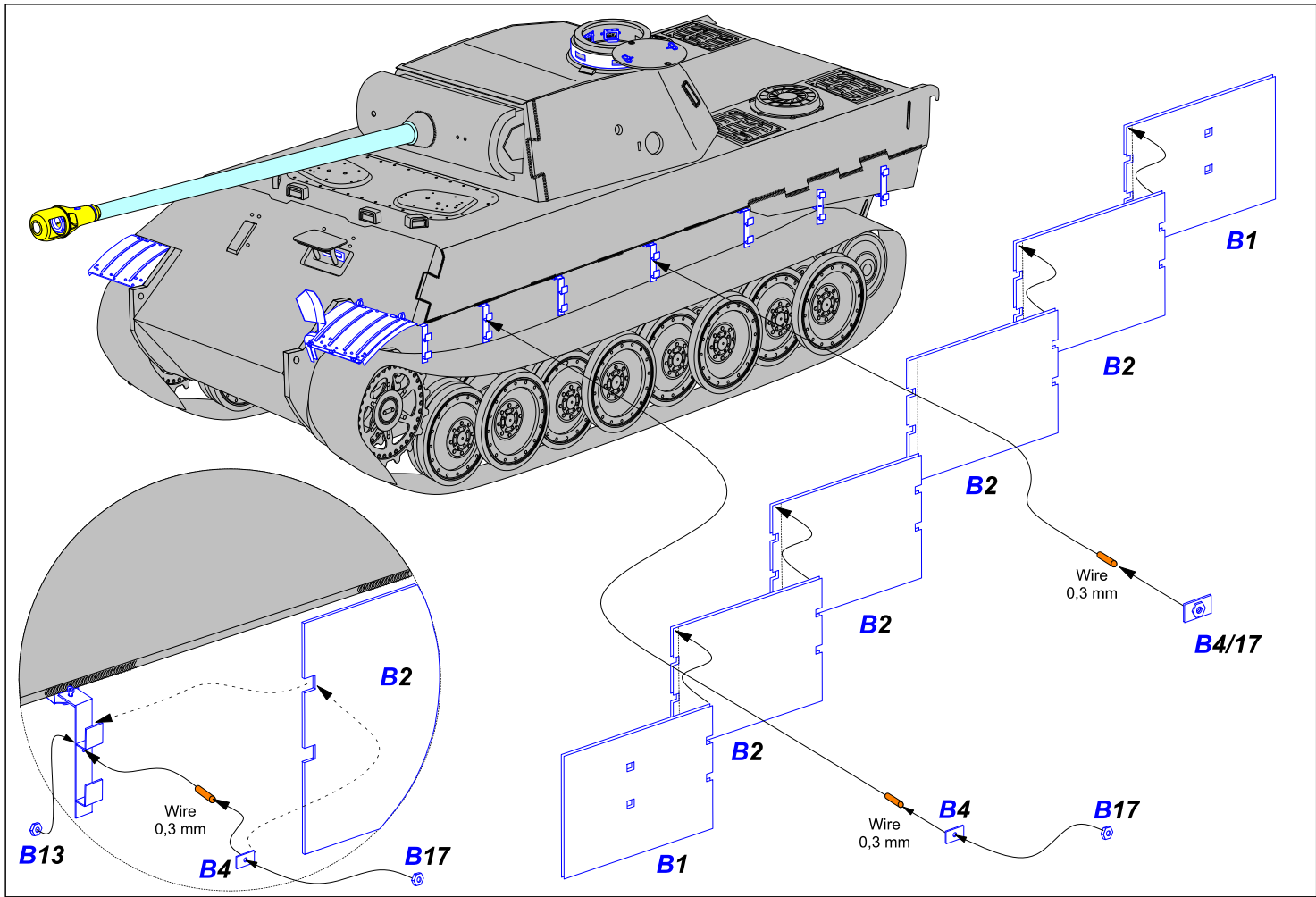

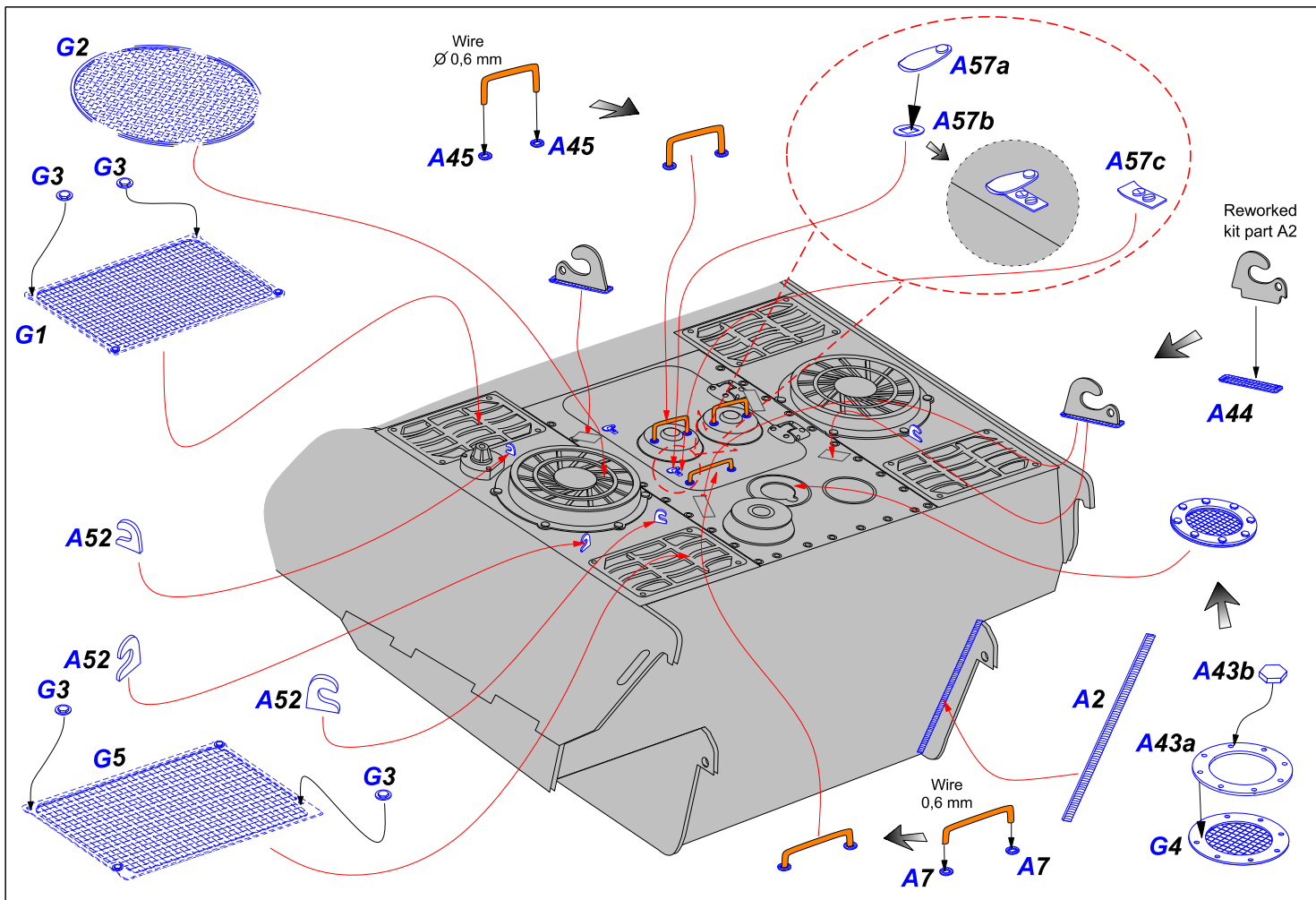

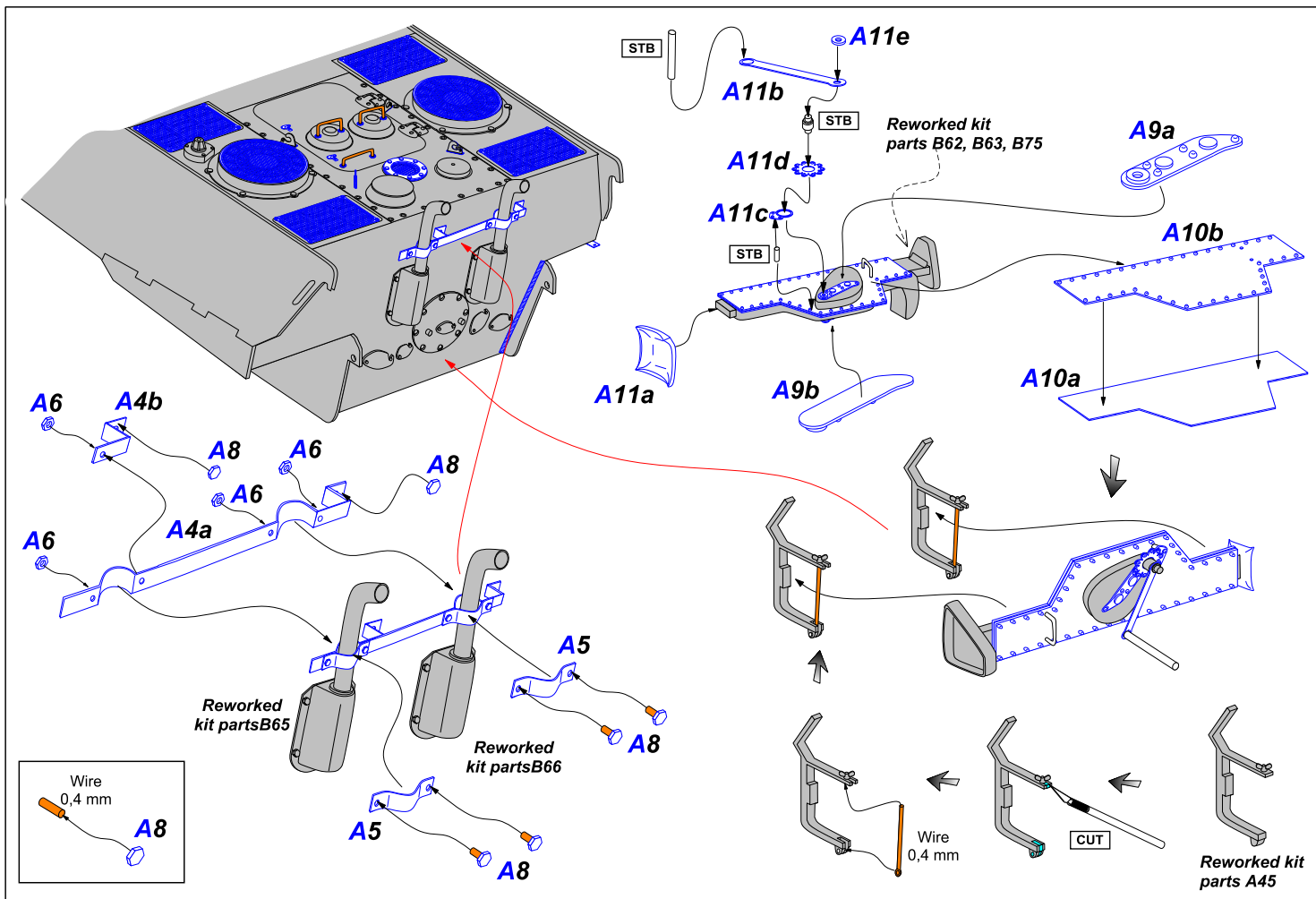

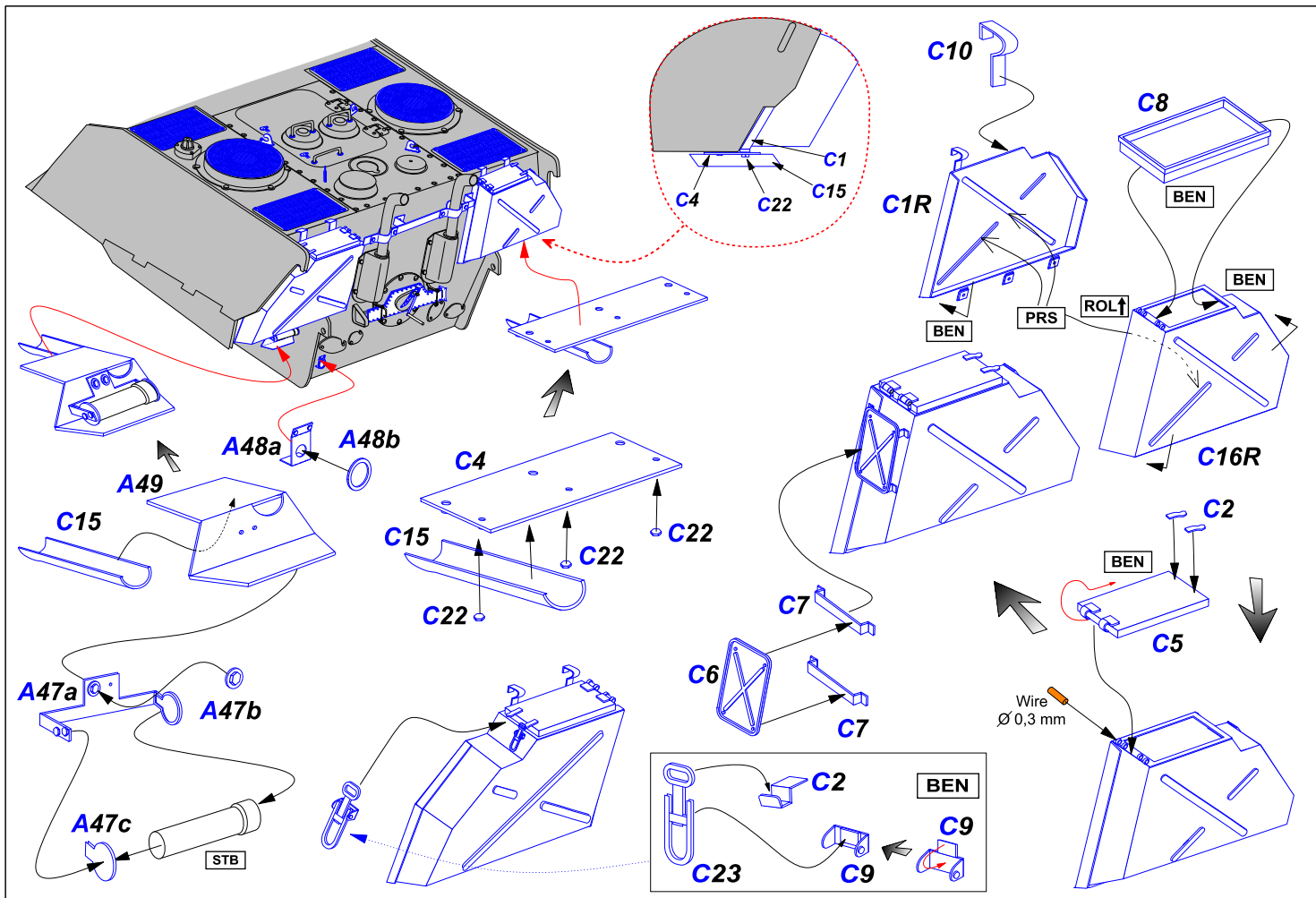

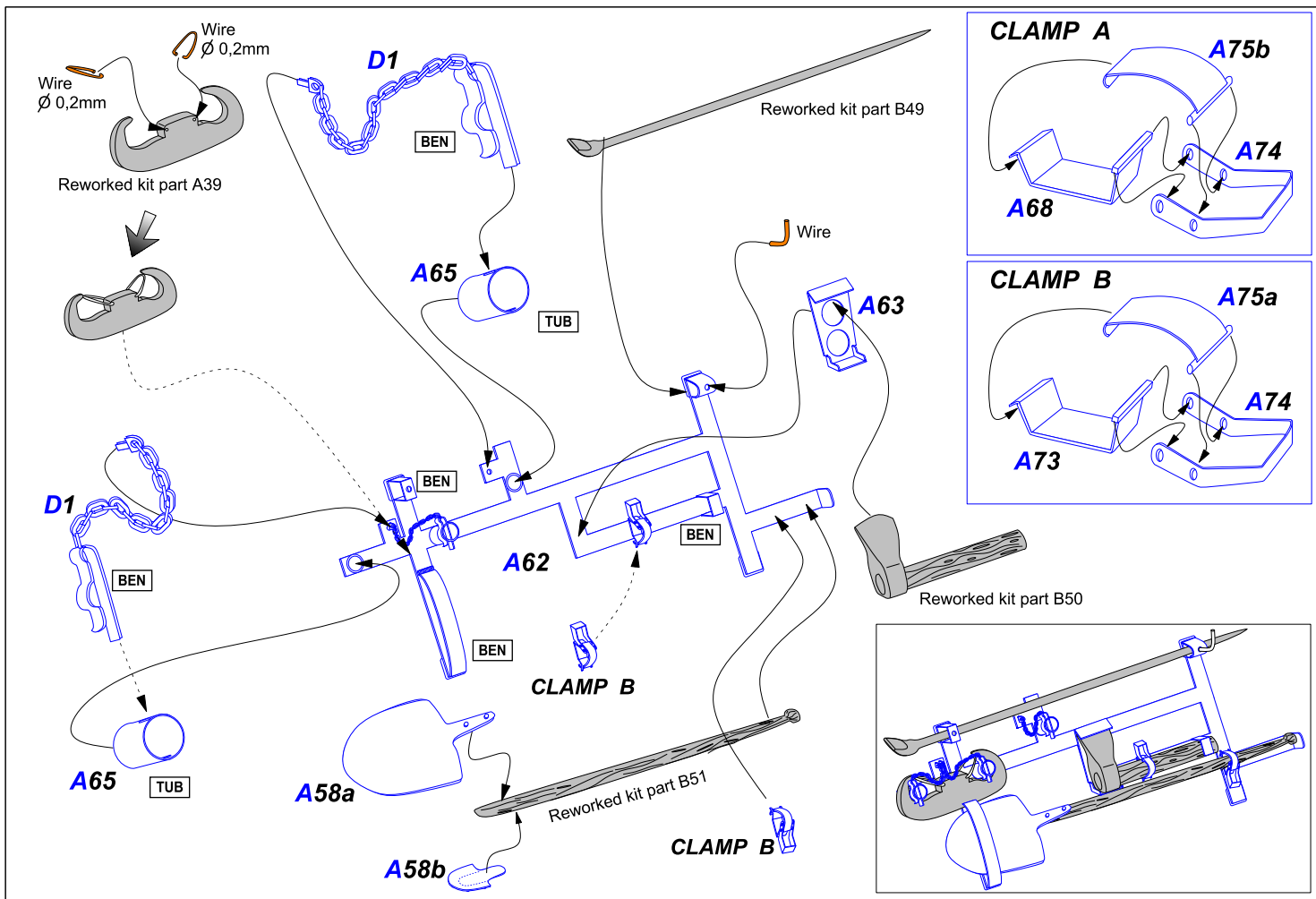

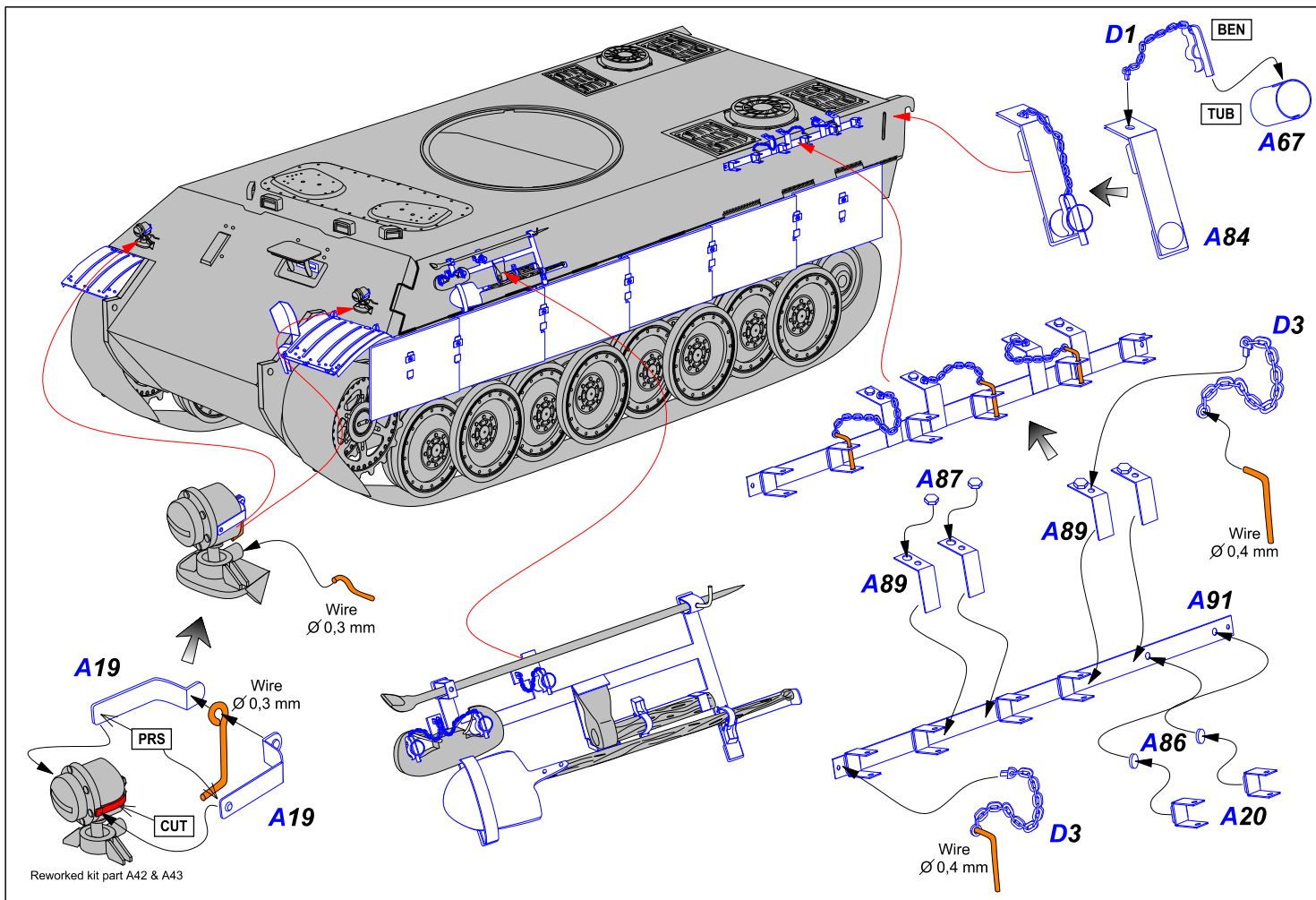

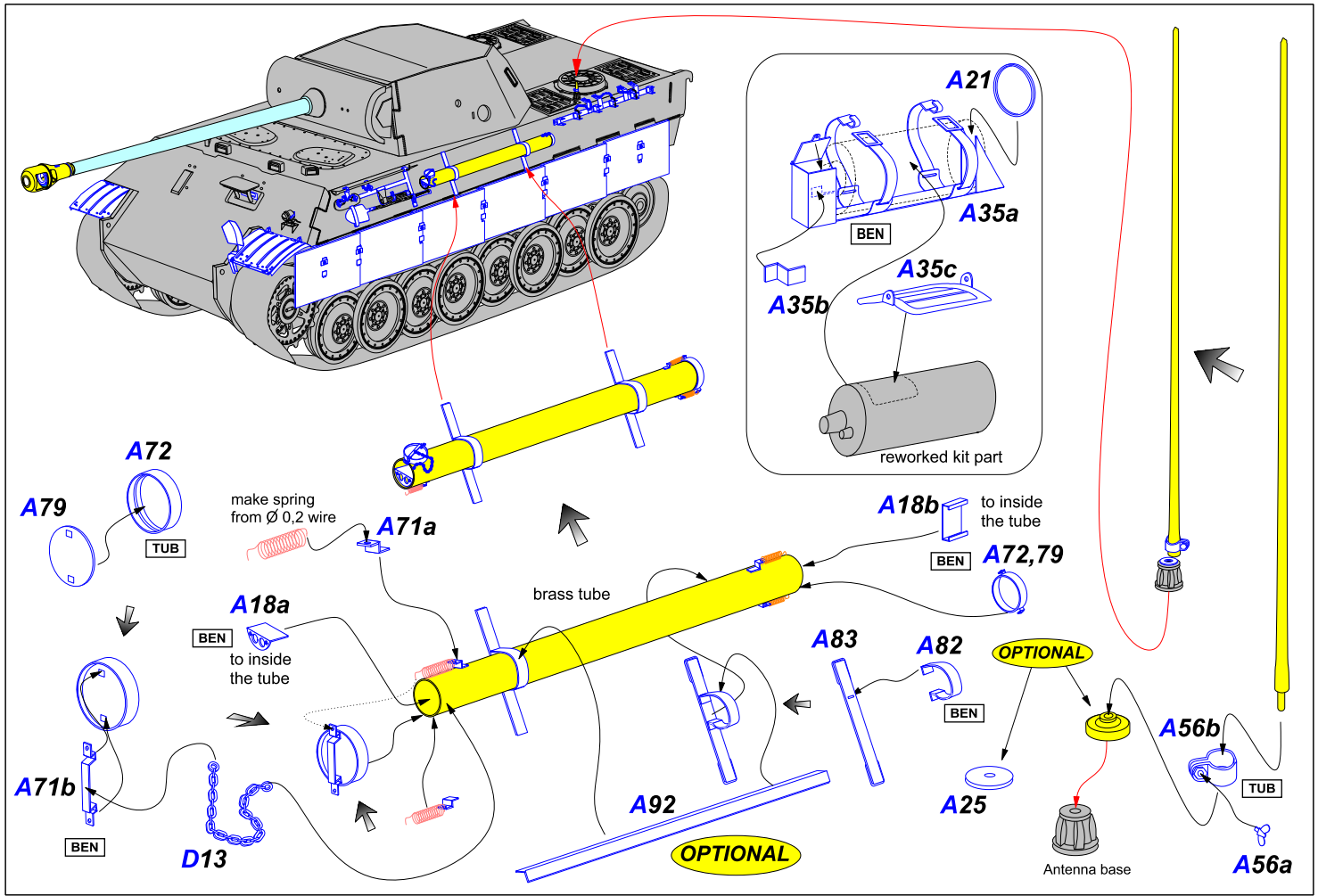

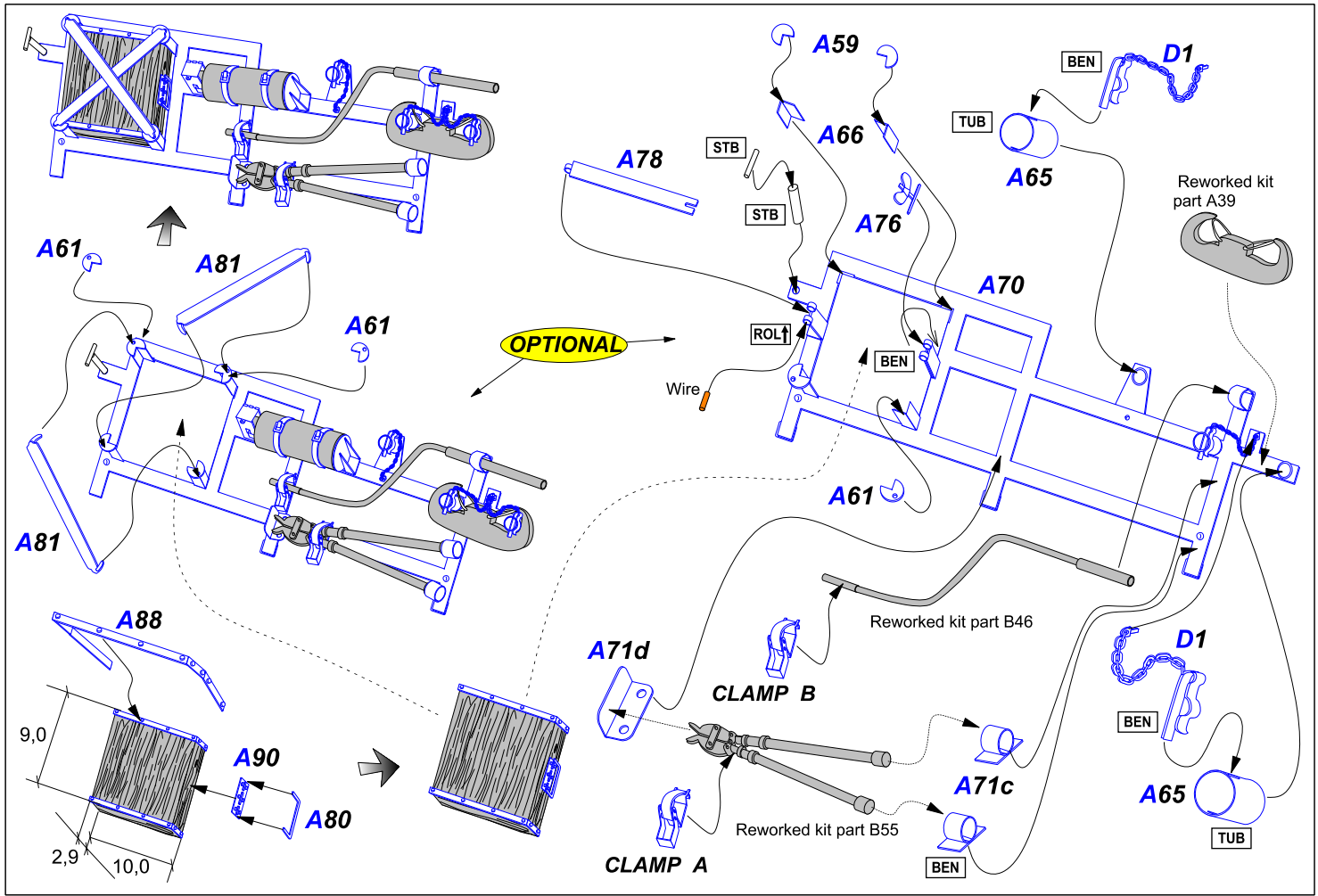

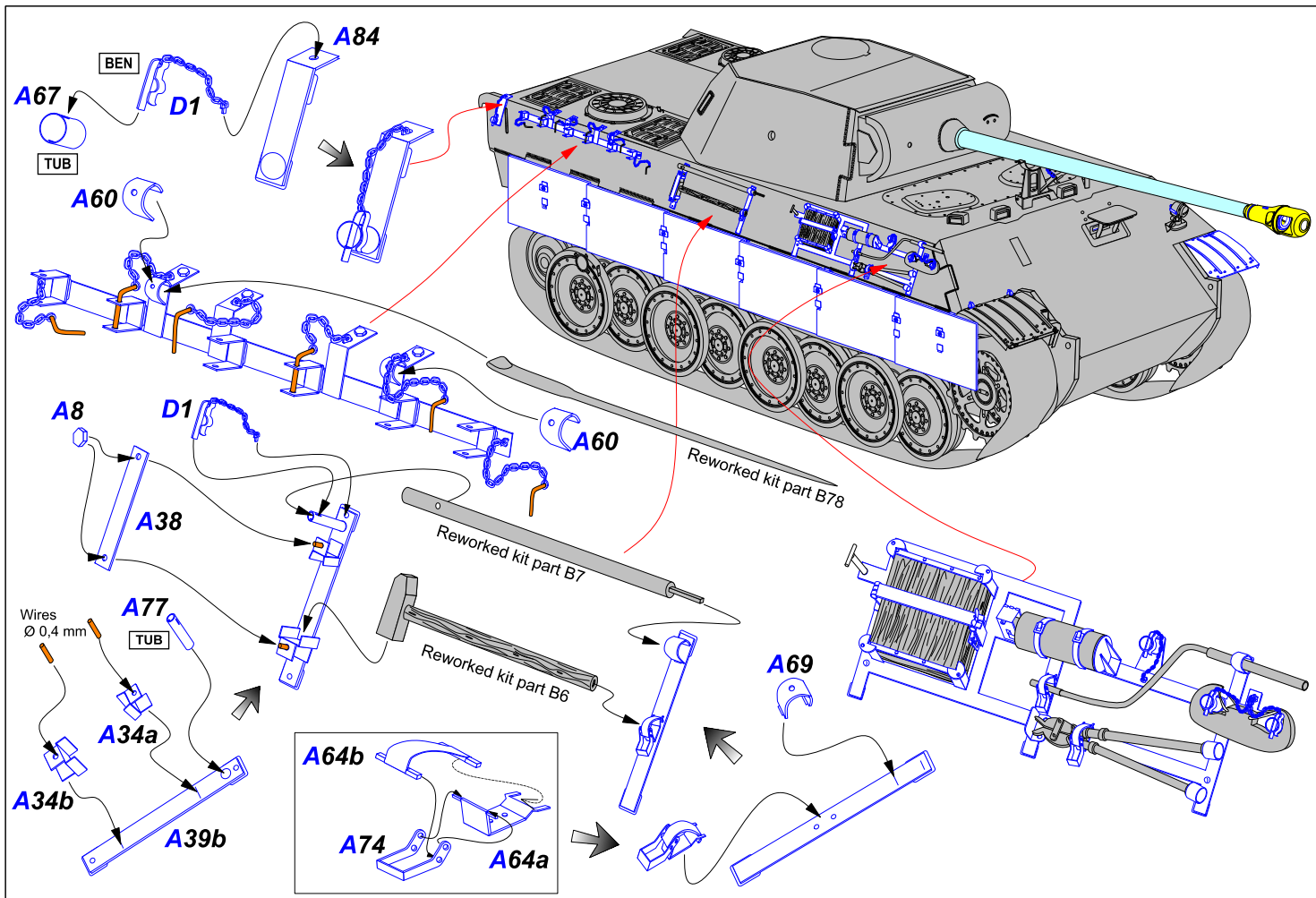

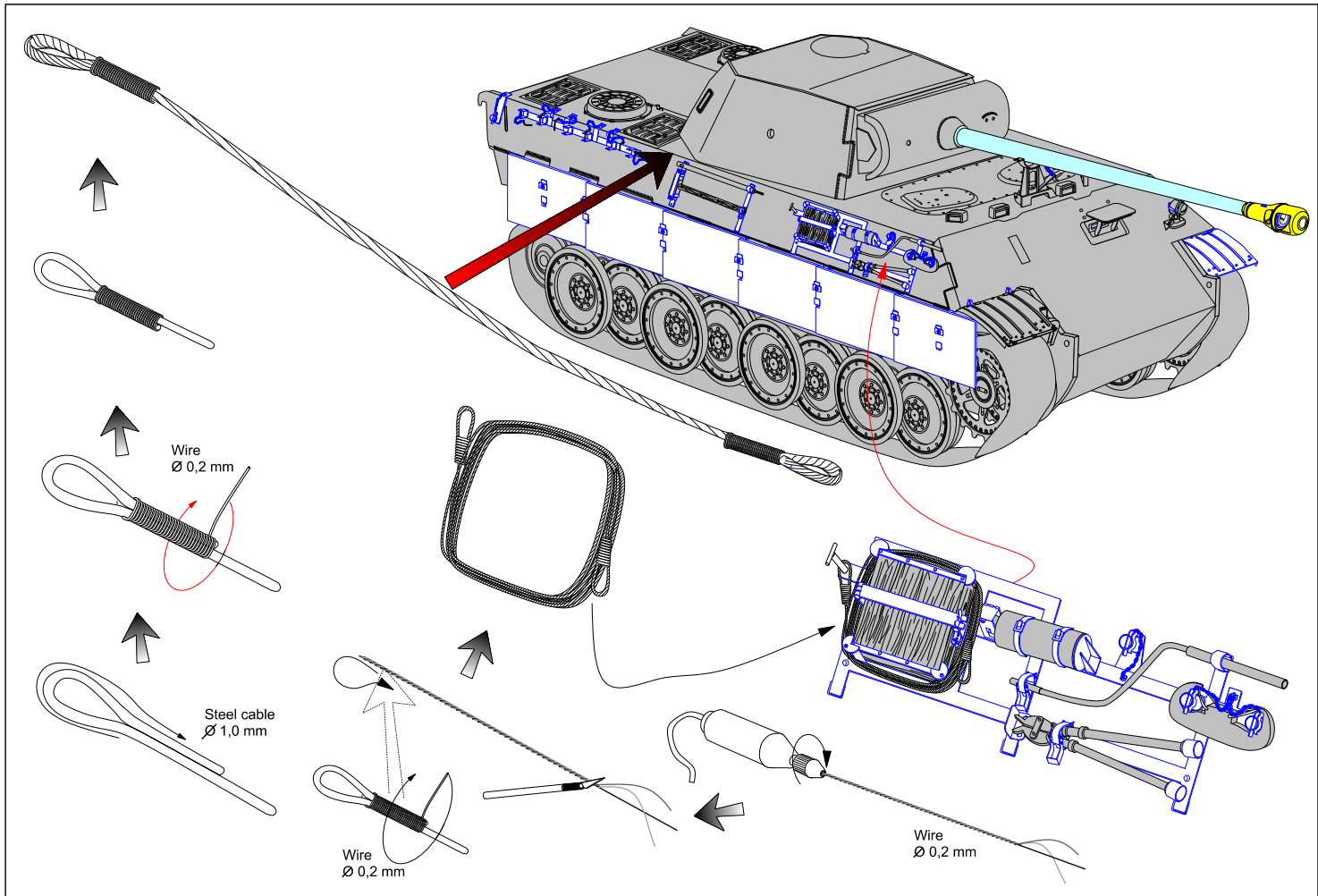

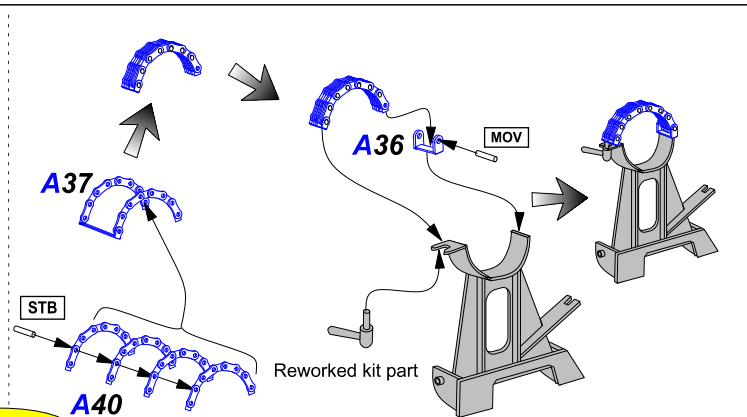
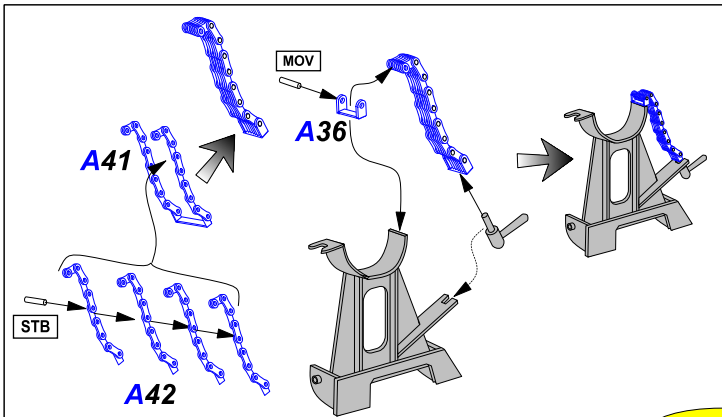

OPTIONAL

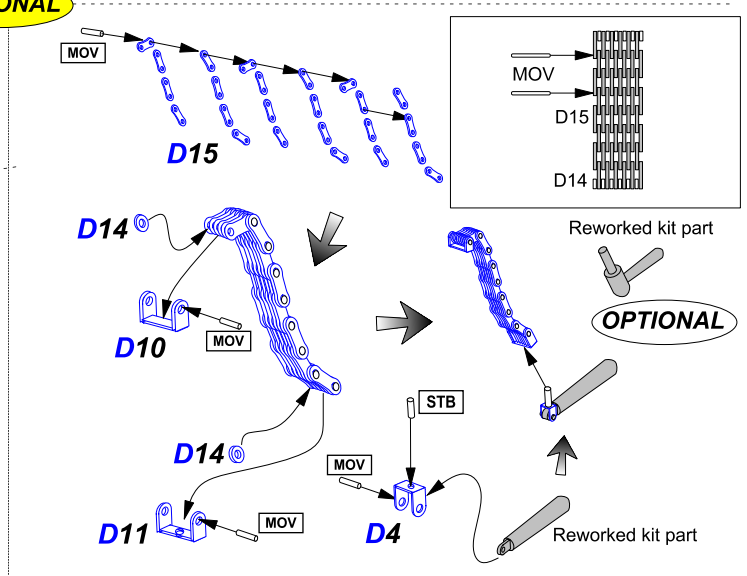
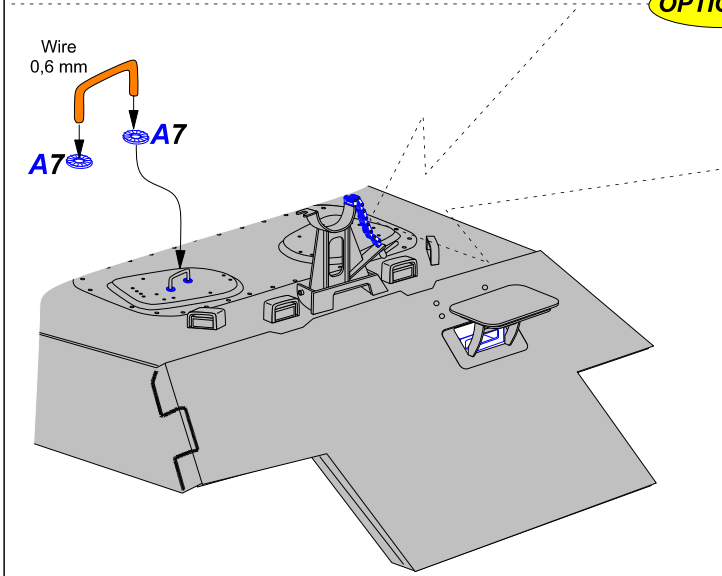

OPTIONAL

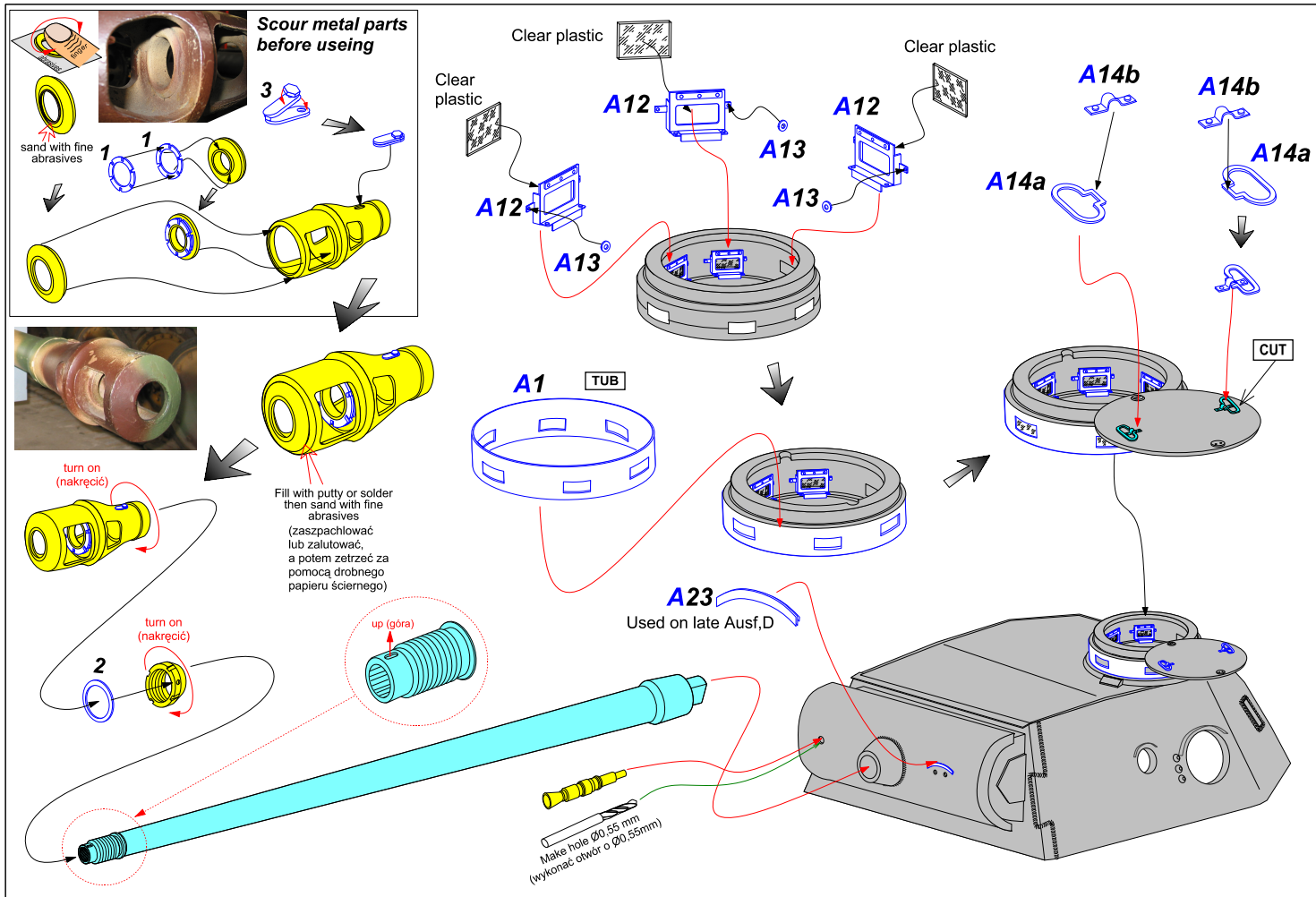

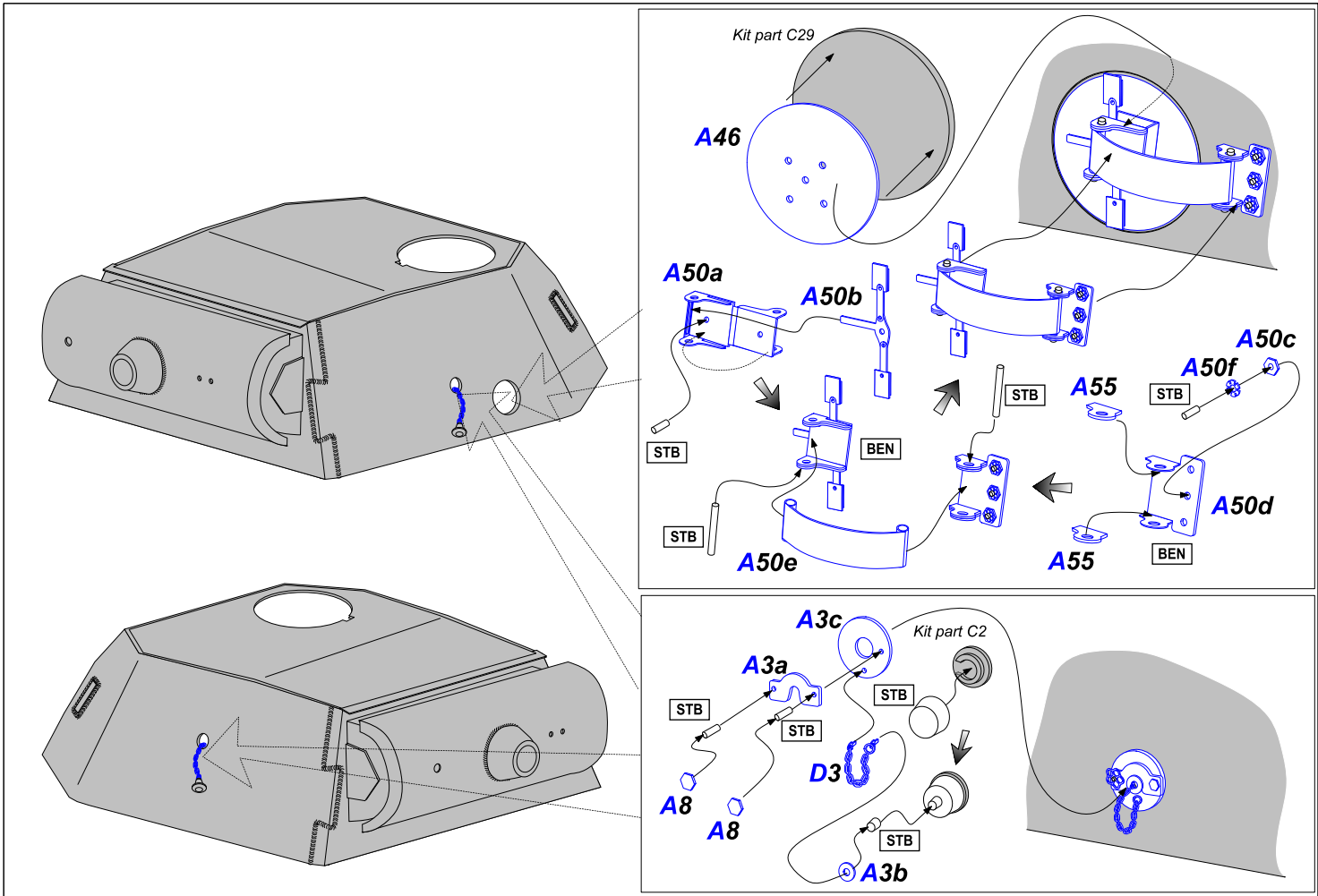

Reworked kit part B67 & C27

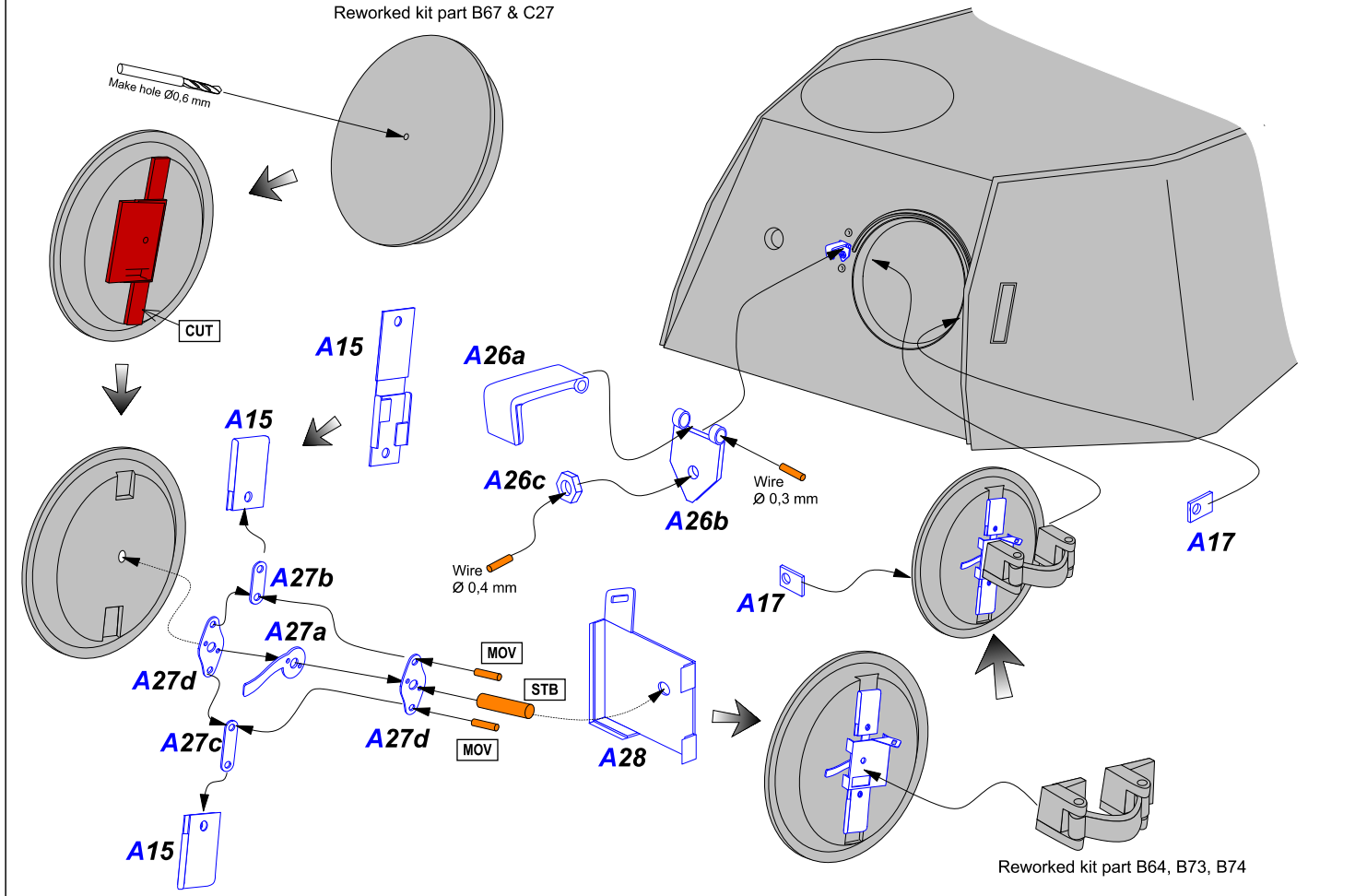

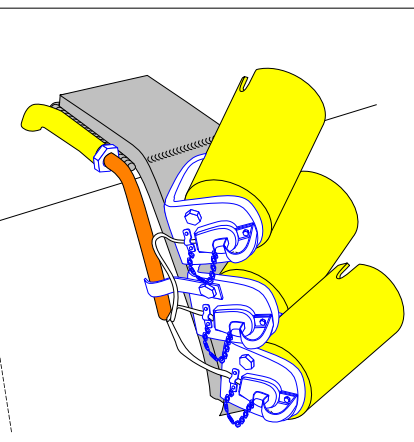
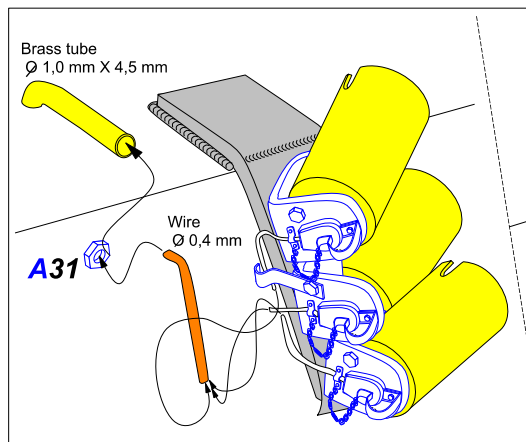
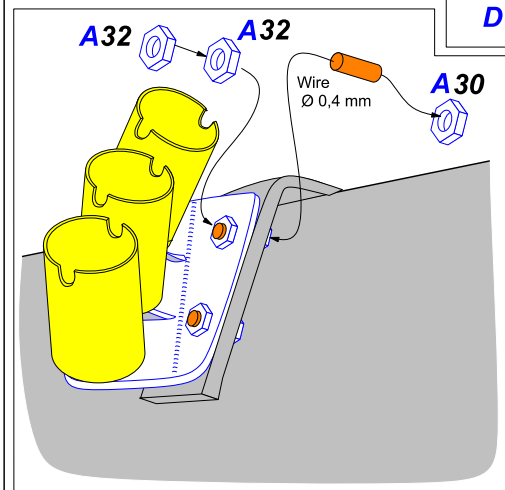
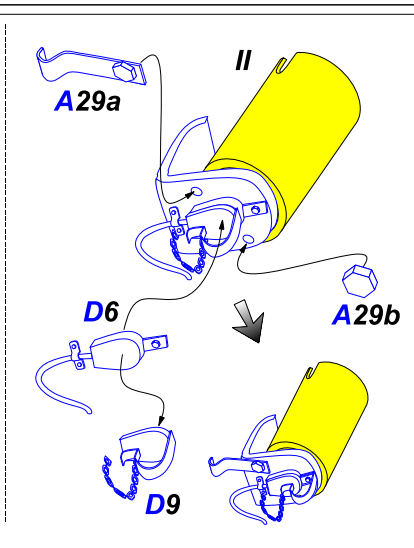
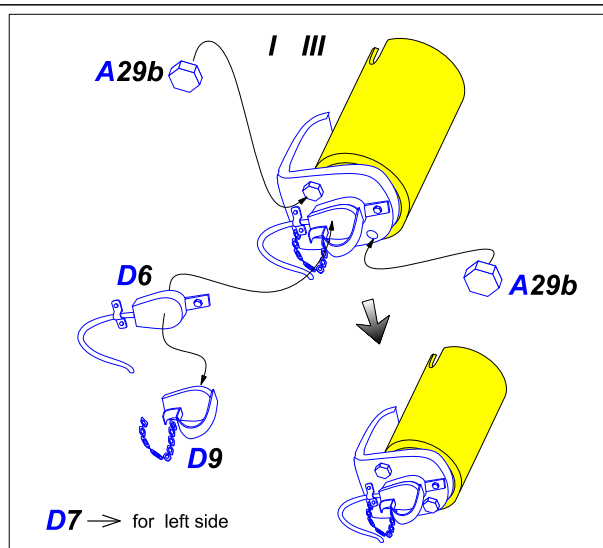
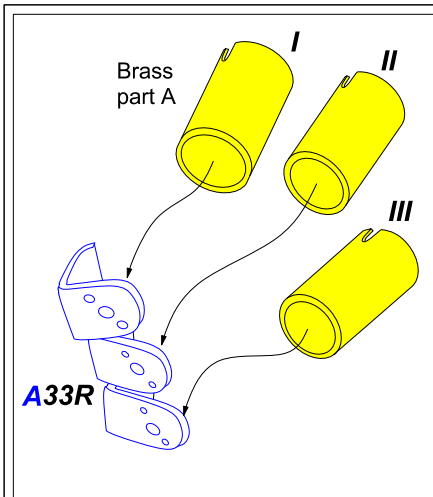

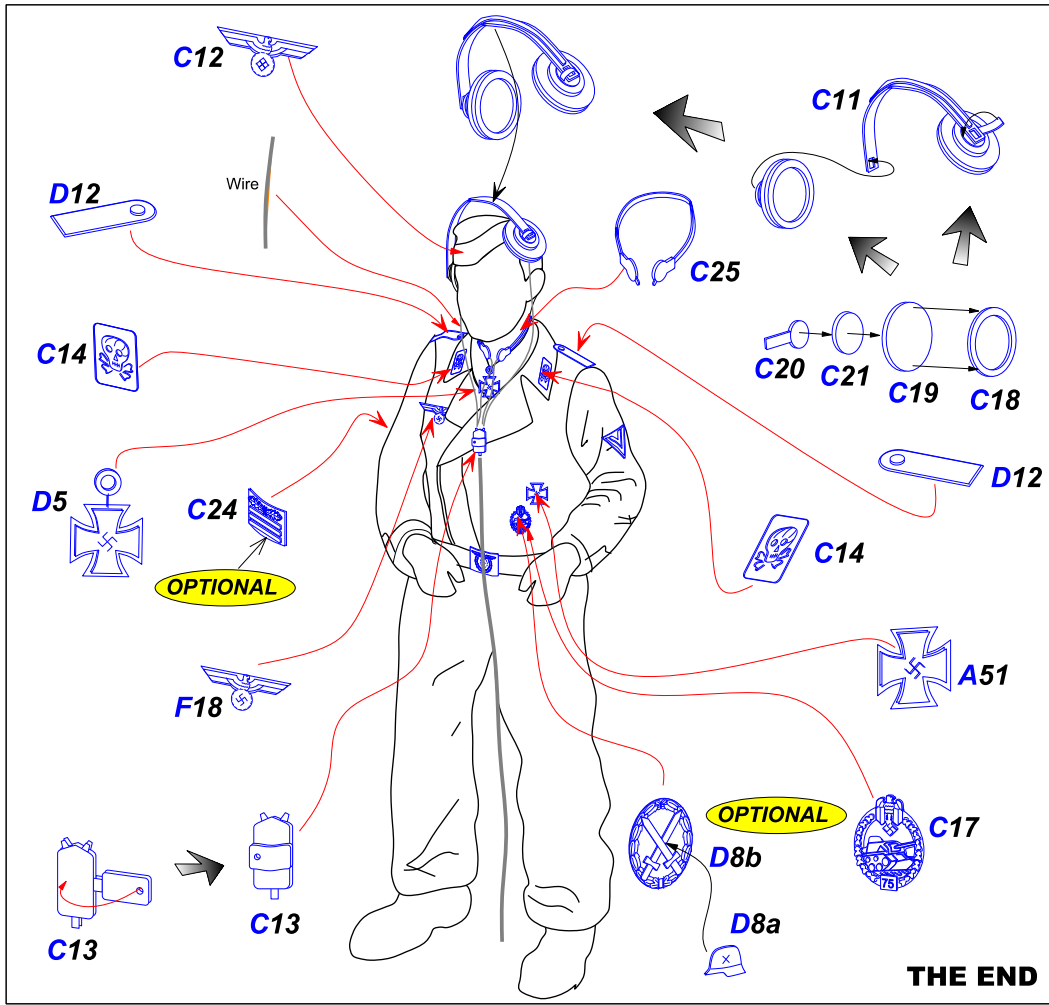

TOOLS RECOMMENDED

