

# CHEVROLET C15TA

## Armoured Truck



Cat. no. 35020

Scale 1/35



3D Design: Przemysław Głogowski  
Supervision & Artwork: Jarosław Leoniec  
Research: IBG crew

IBG Models pragnie podziękować Panu Michałowi Wąsowiczowi za pomoc w wykonaniu zdjęć do materiałów źródłowych.  
IBG Models want to thank to Mr. Michał Wąsowicz for his help in making photos for research.

1 Element złożony we wcześniejszym etapie  
Element assembled in previous step

▲ Element po złożeniu w aktualnym etapie  
Element after assembly in actual step

? Wersja do wyboru  
Version to choose

1 Kalkomania  
Decal

A Kolor farby  
Paint colour

■ Część nie do użycia  
Part not for use

45° Zegnij część fototrawioną  
Bend photoetched part

▲ Po gięciu  
After bending

		Vallejo Model Air	Vallejo Model Color
black	▲ A	71057	70950
rust	▲ B	71080	70846
gunmetal	▲ C	71072	70863
olive drab	▲ D	71043	70889

Przed montażem przeczytać instrukcję. Przestrzegać kolejności montażu podanego w instrukcji! Klej i farby nie wchodzi w skład zestawu.  
Please read instruction before assembly. Obey sequence of assembly like in instruction. Glue and paints not included.

Ramka przezroczysta / Frame clear

Części fototrawione B01 / Photoetched parts B01

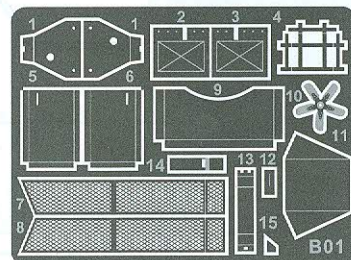
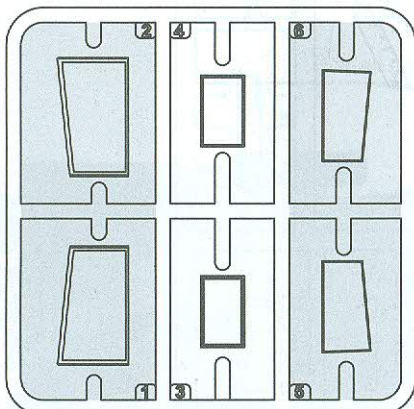

International Business Group  
ul. Benedykta Hertza 2  
04-603 Warszawa  
Poland

tel +48 22 8159150  
fax +48 22 8159151  
ibgsc@ibg.com.pl  
www.ibg.com.pl  
www.ibgmodels.com

## Ramka A / Frame A

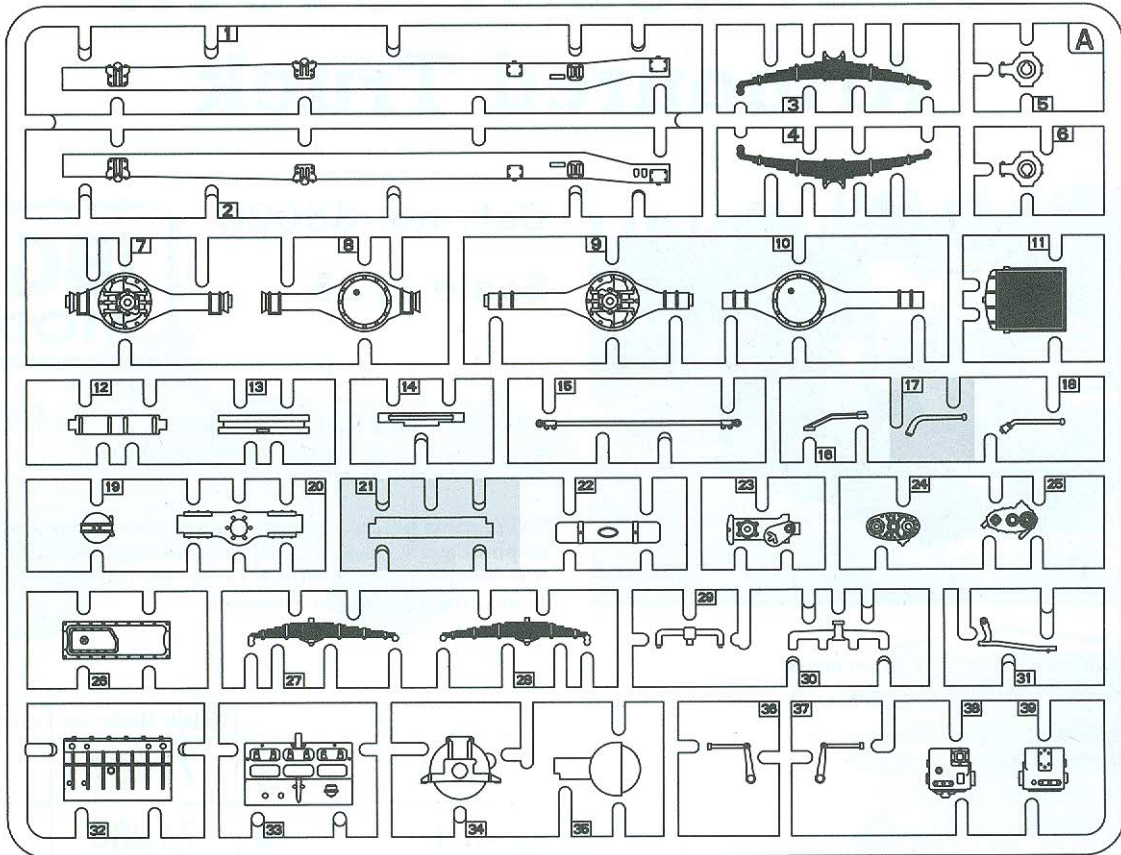

## Ramka H / Frame H

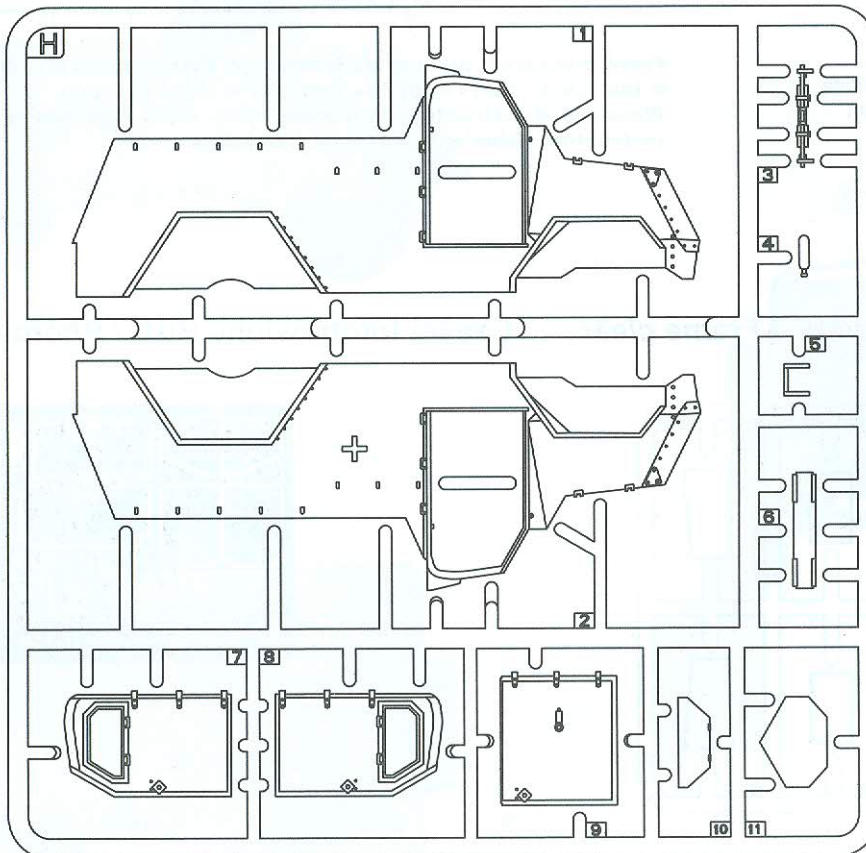

Ramka I / Frame I

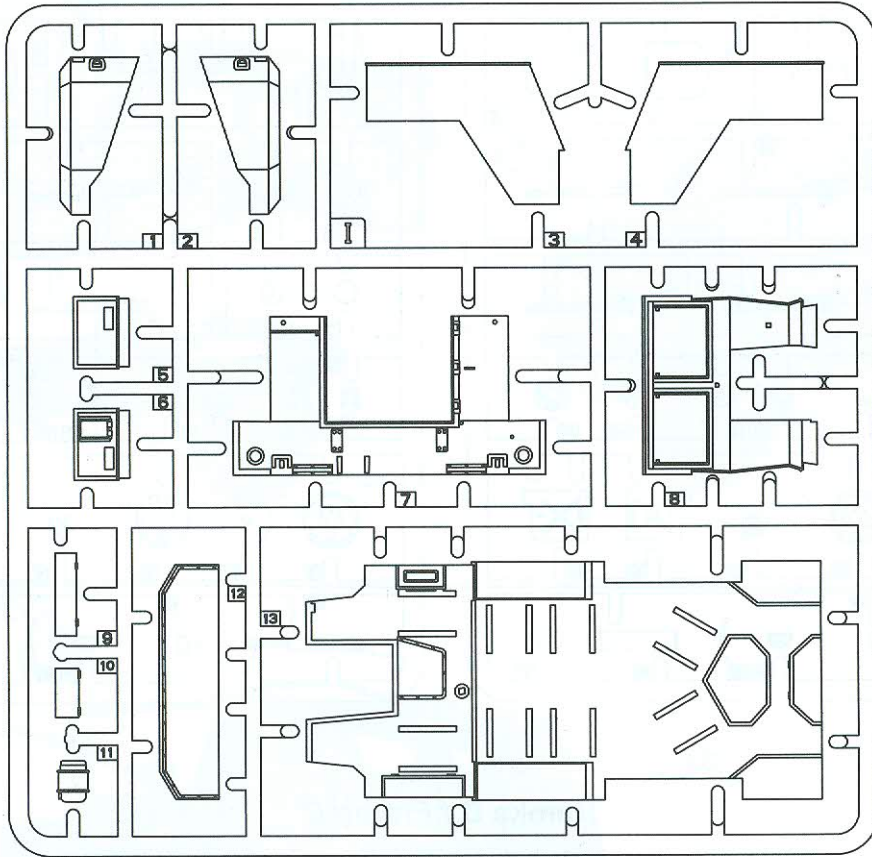

Ramki L - 2 szt / Frames L - 2 pcs

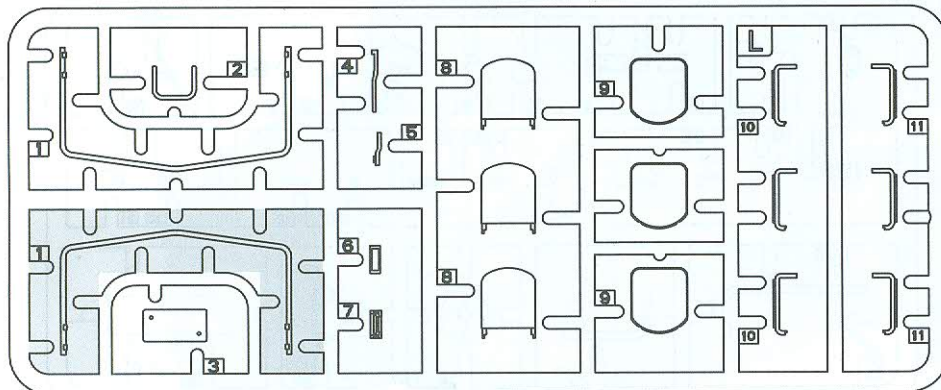
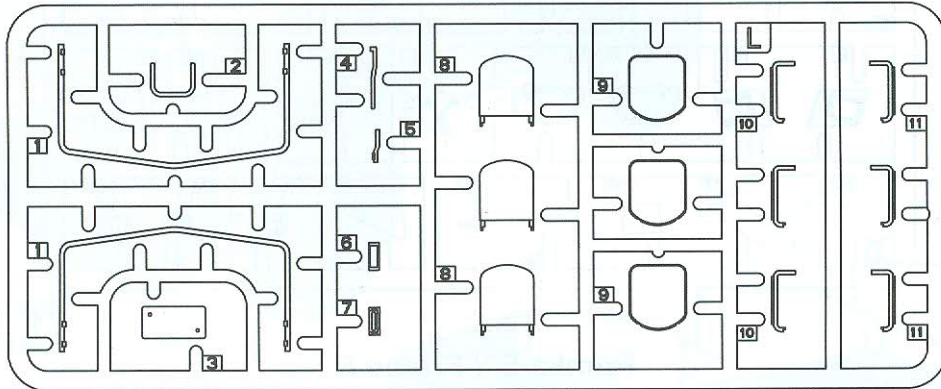

Ramki J - 2 szt / Frames J - 2 pcs

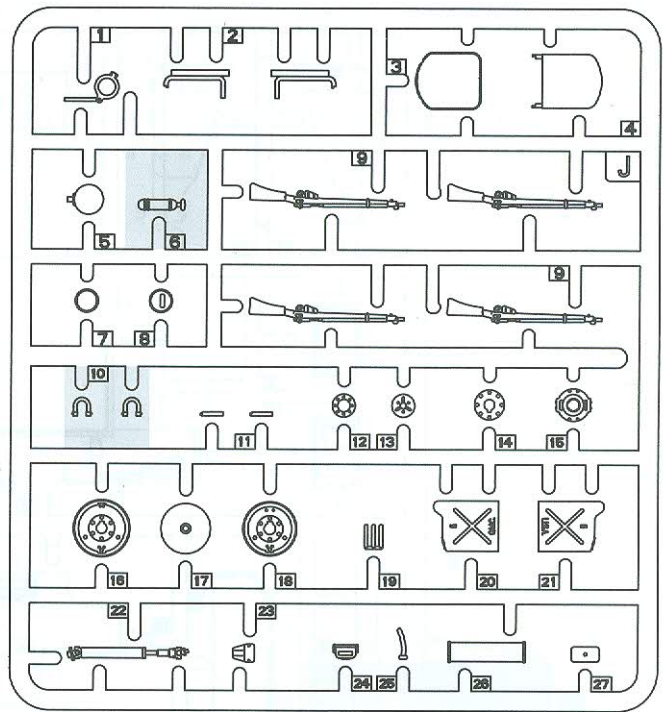
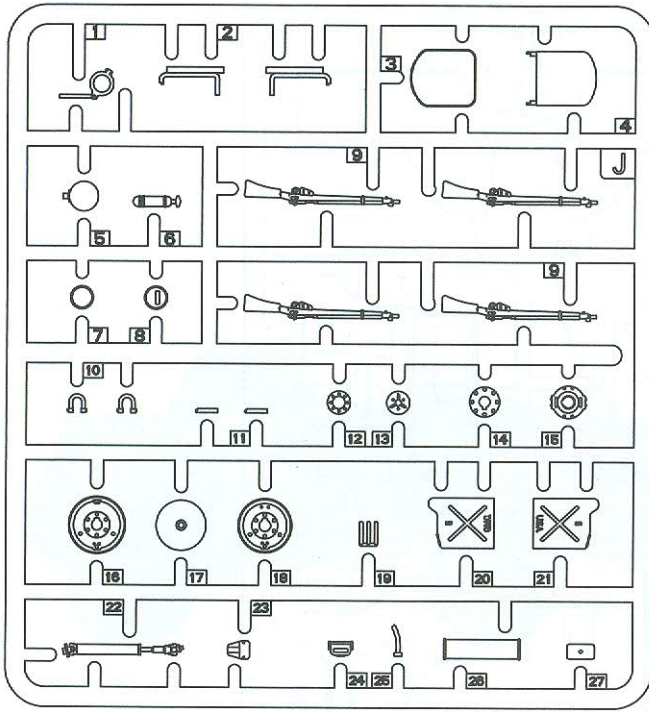

Ramka D / Frame D

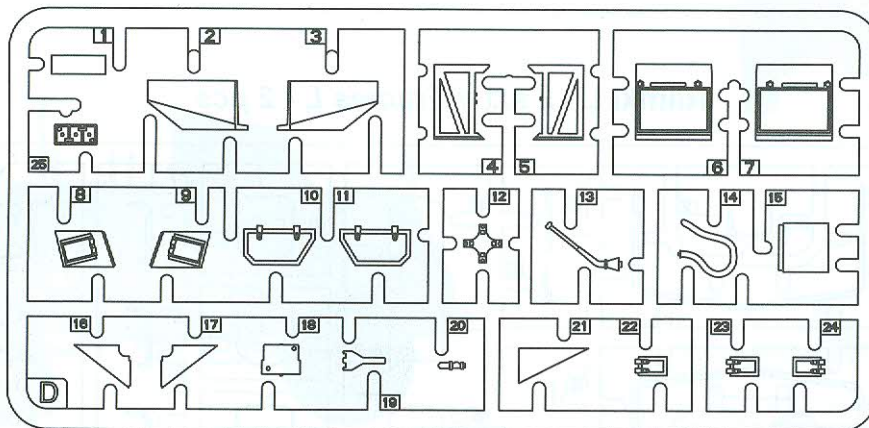

Ramka E / Frame E

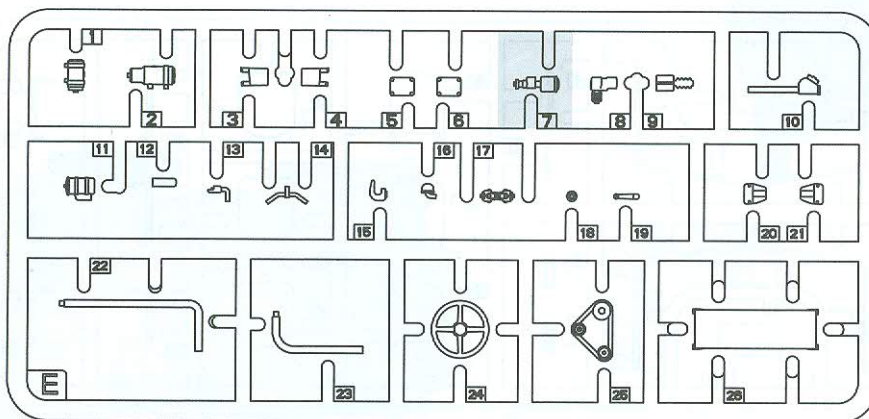

Ramka B / Frame B

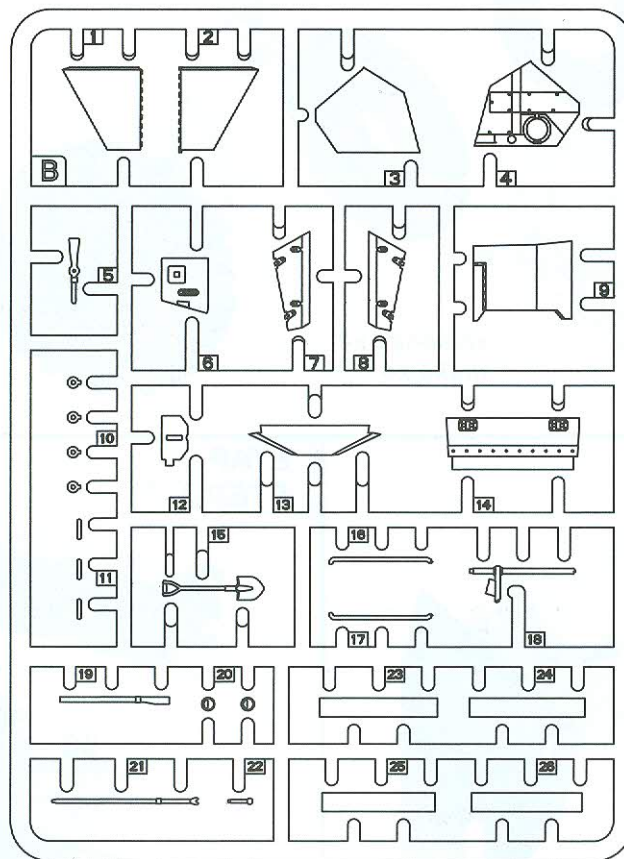

Ramki N - 2 szt / Frames N - 2 pcs

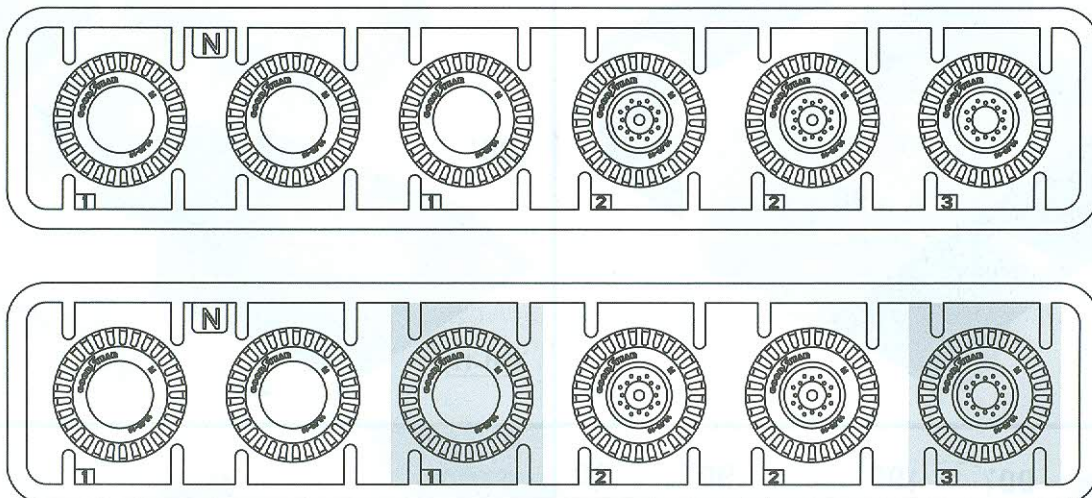

**Uwaga!**

Ramki M - 2 szt i O - 2 szt nie są używane w budowie tego modelu.

**Attention!**

Frames M - 2 pcs and O - 2 pcs are not used in building this model.

International Business Group  
ul. Benedykta Hertza 2  
04-603 Warszawa  
Poland

tel +48 22 8159150  
fax +48 22 8159151  
ibgsc@ibg.com.pl  
www.ibg.com.pl  
www.ibgmodels.com

**ETAP 1  
STEP 1**

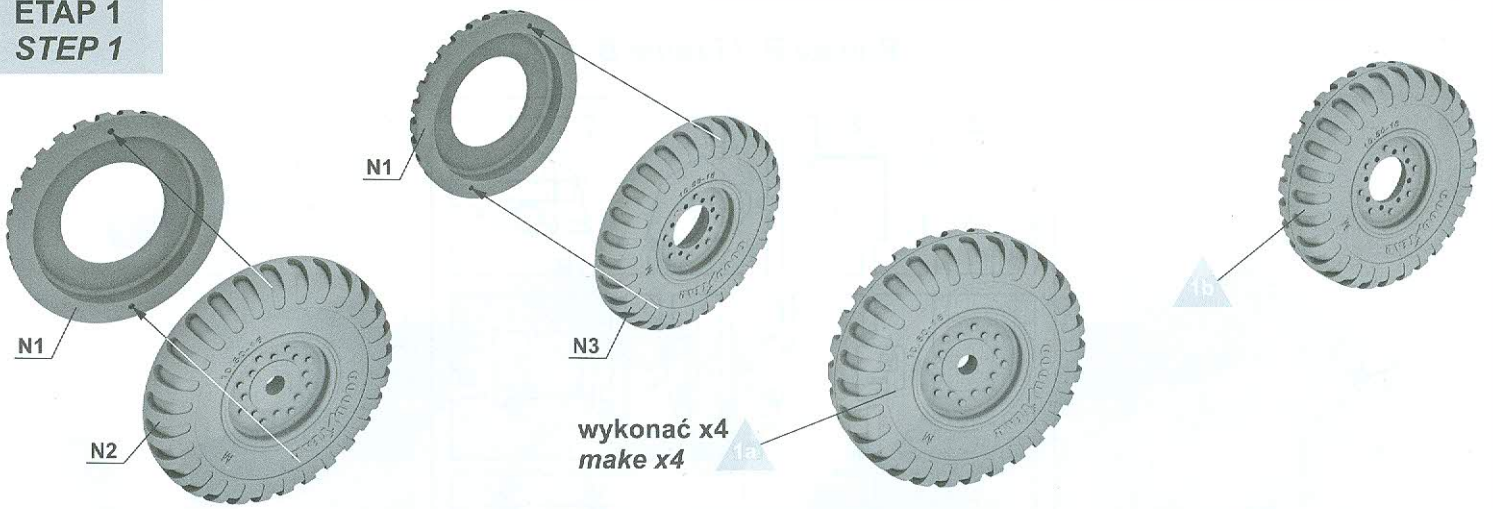

**ETAP 2  
STEP 2**

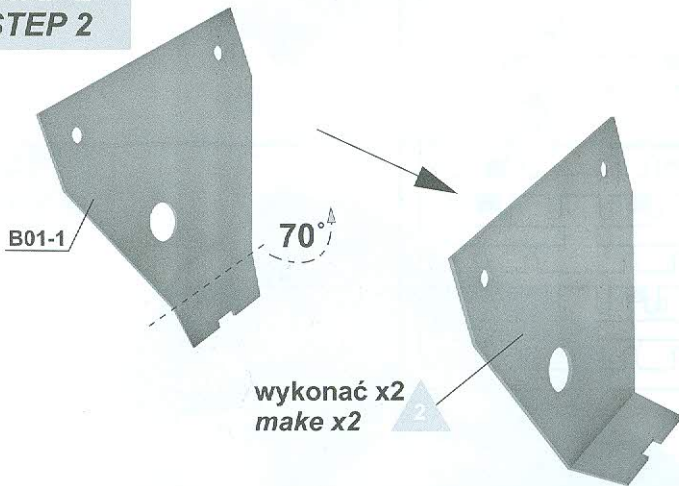

**ETAP 3  
STEP 3**

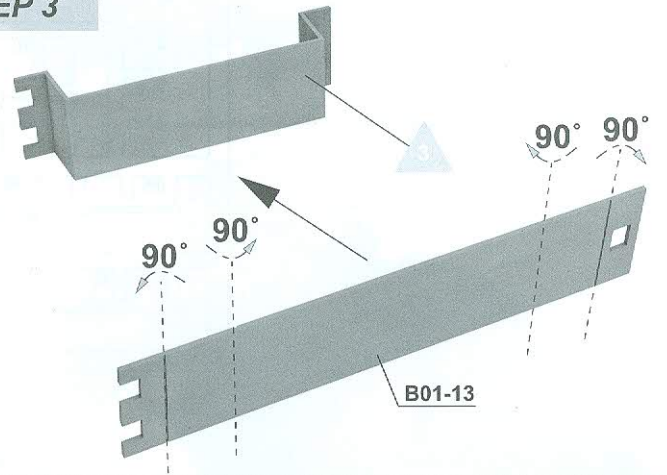

**ETAP 4  
STEP 4**

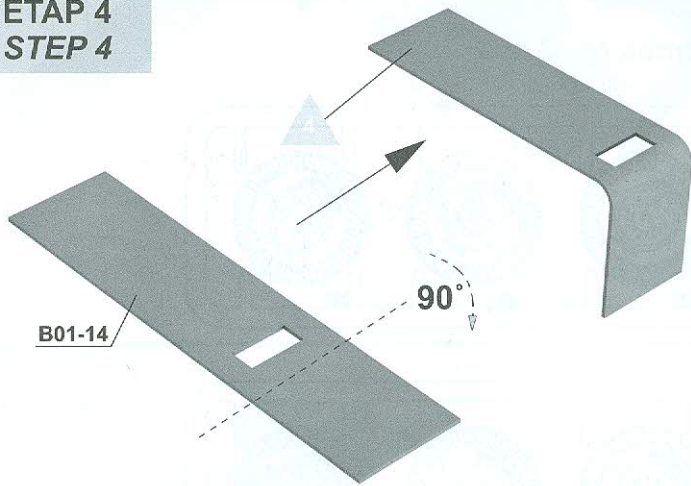

**ETAP 5  
STEP 5**

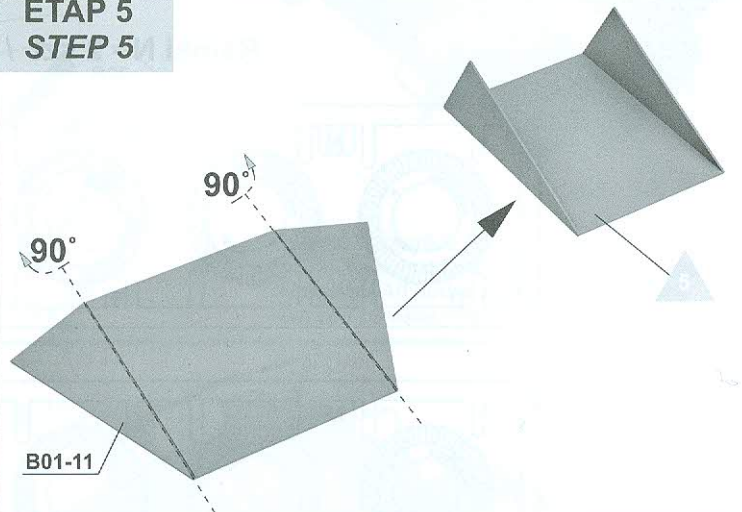

**ETAP 6  
STEP 6**

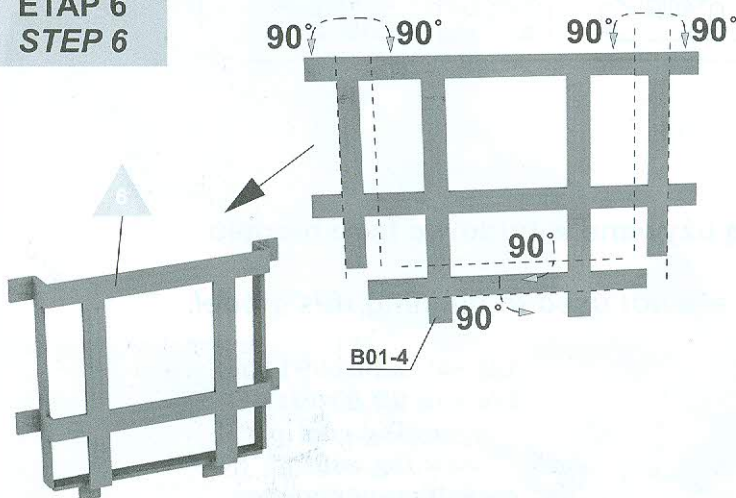

**ETAP 7  
STEP 7**

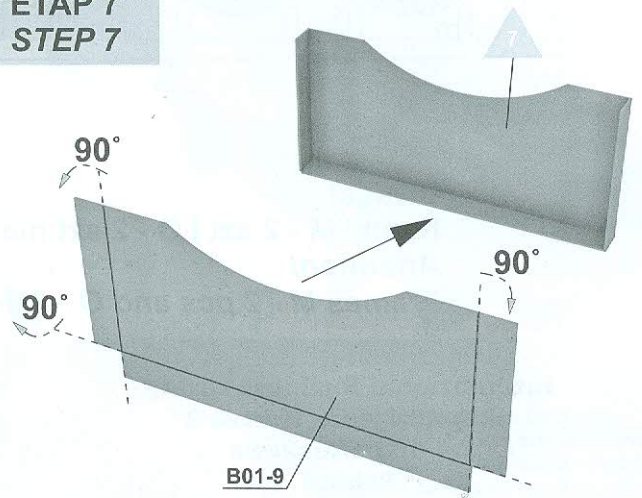

**ETAP 8  
STEP 8**

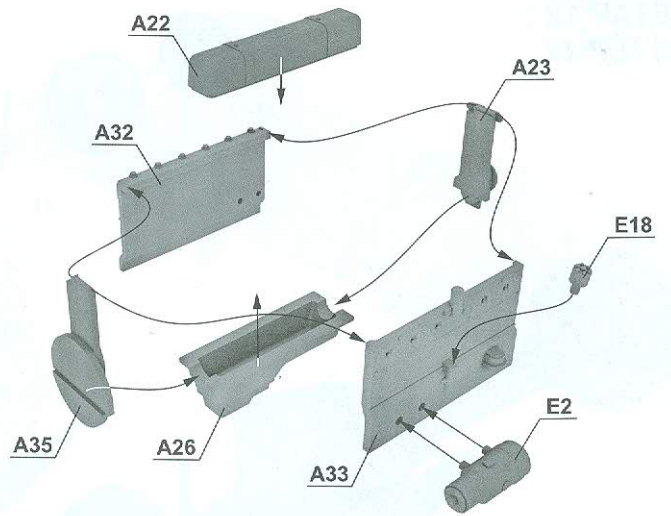
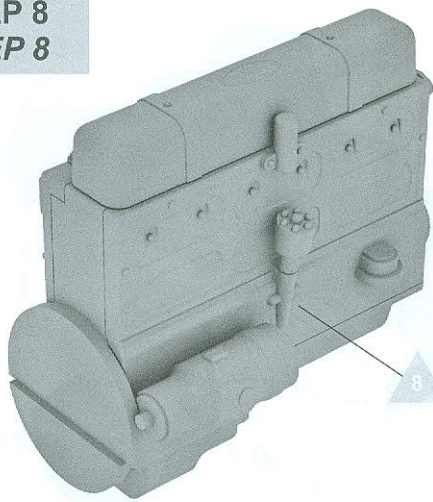

**ETAP 9  
STEP 9**

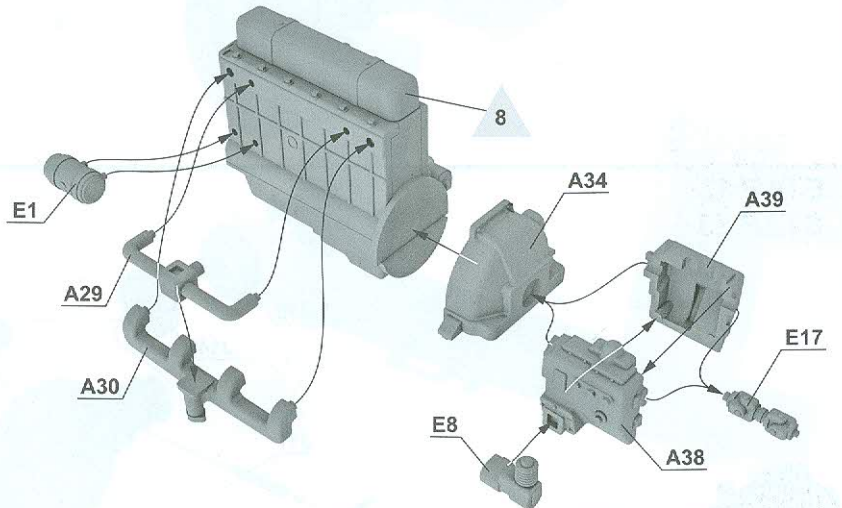
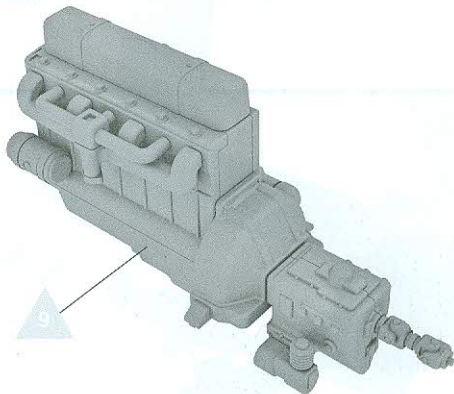

**ETAP 10  
STEP 10**

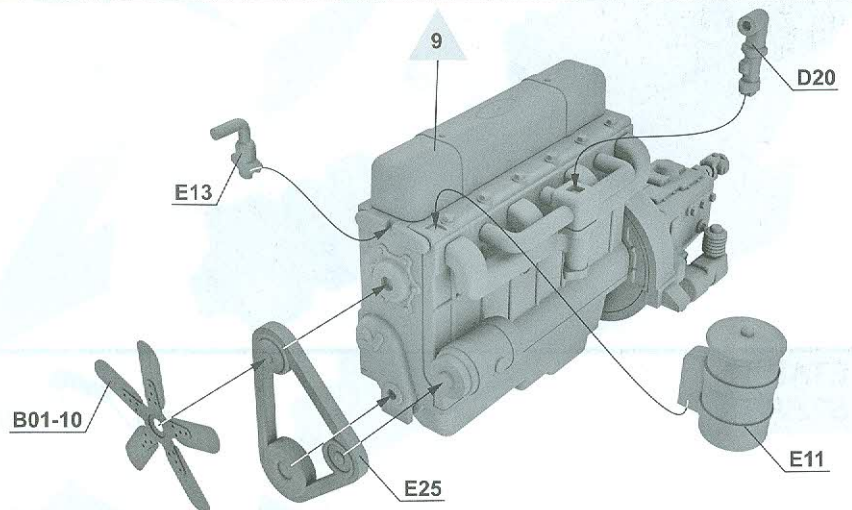
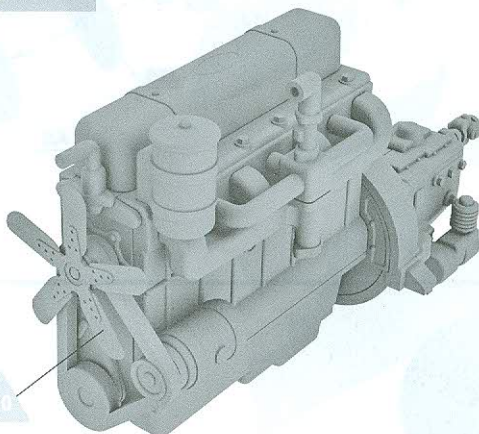

**ETAP 11  
STEP 11**

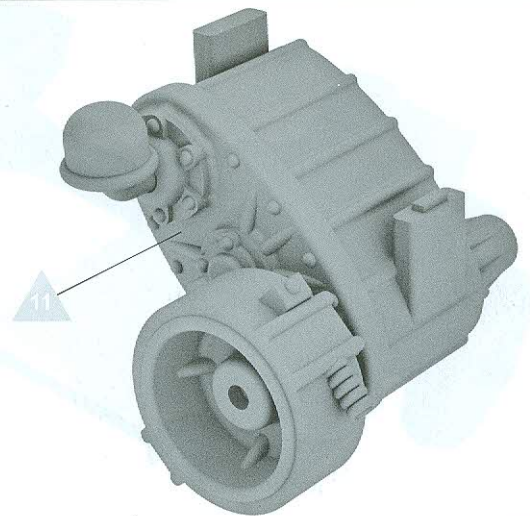
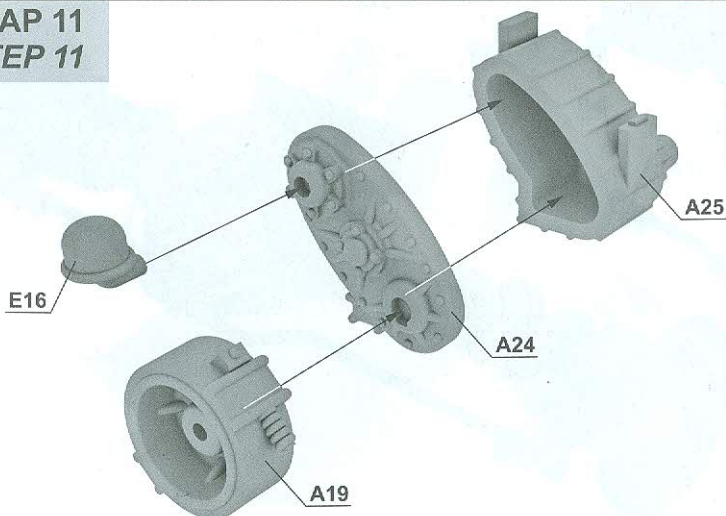

**ETAP 12**  
**STEP 12**

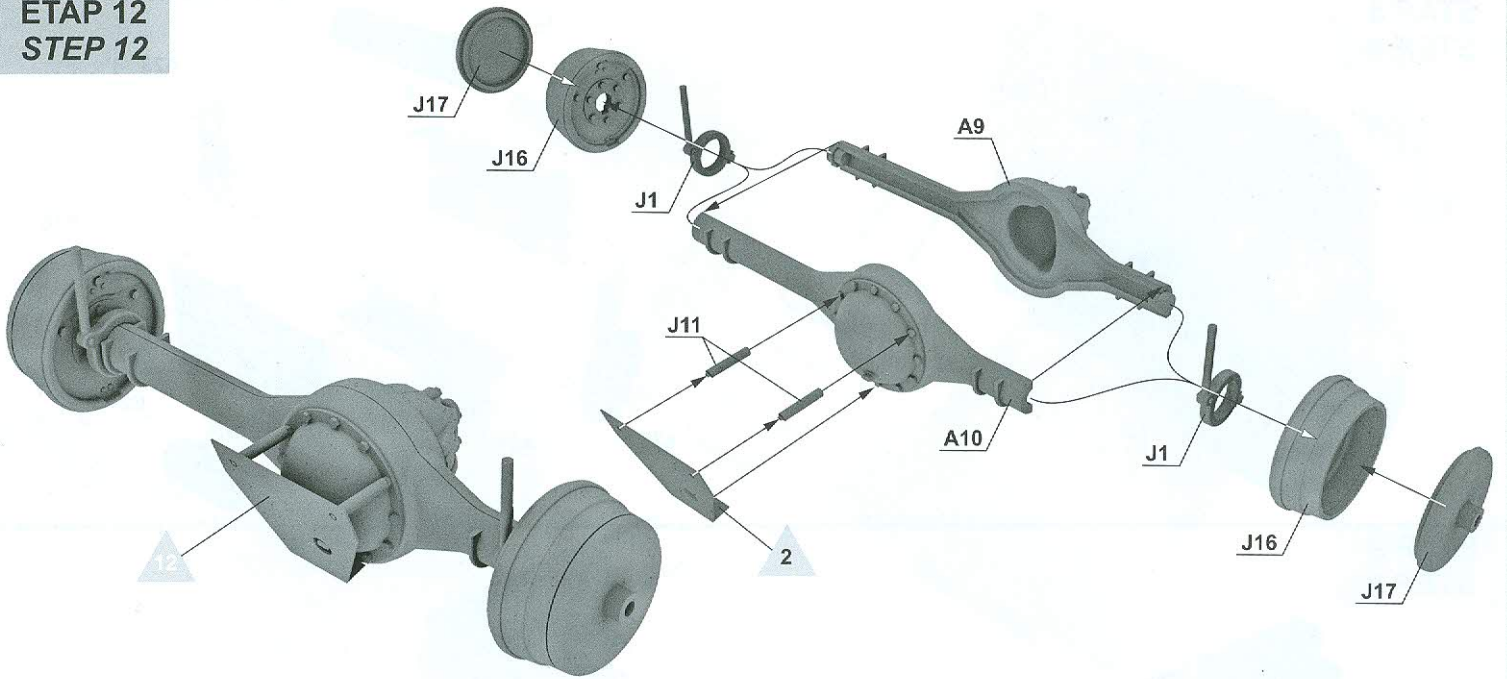

**ETAP 13**  
**STEP 13**

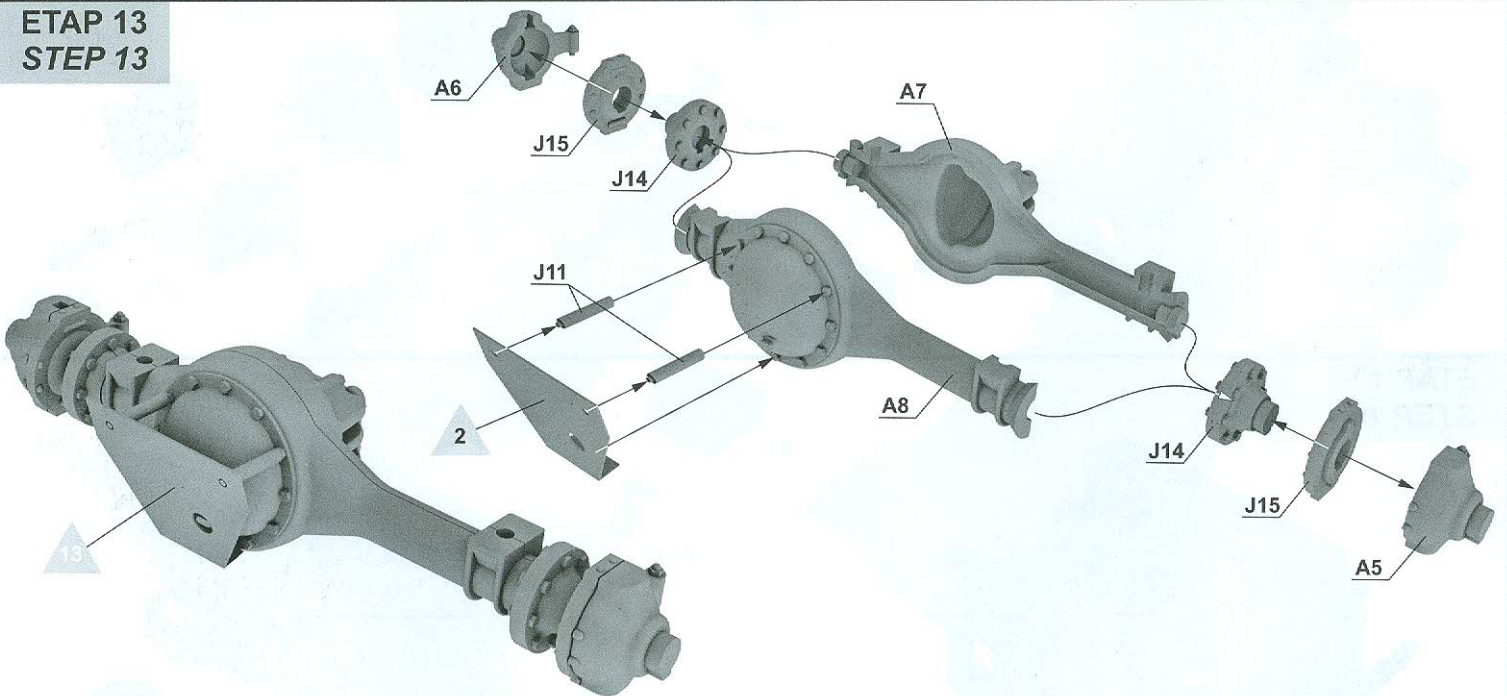

**ETAP 14**  
**STEP 14**

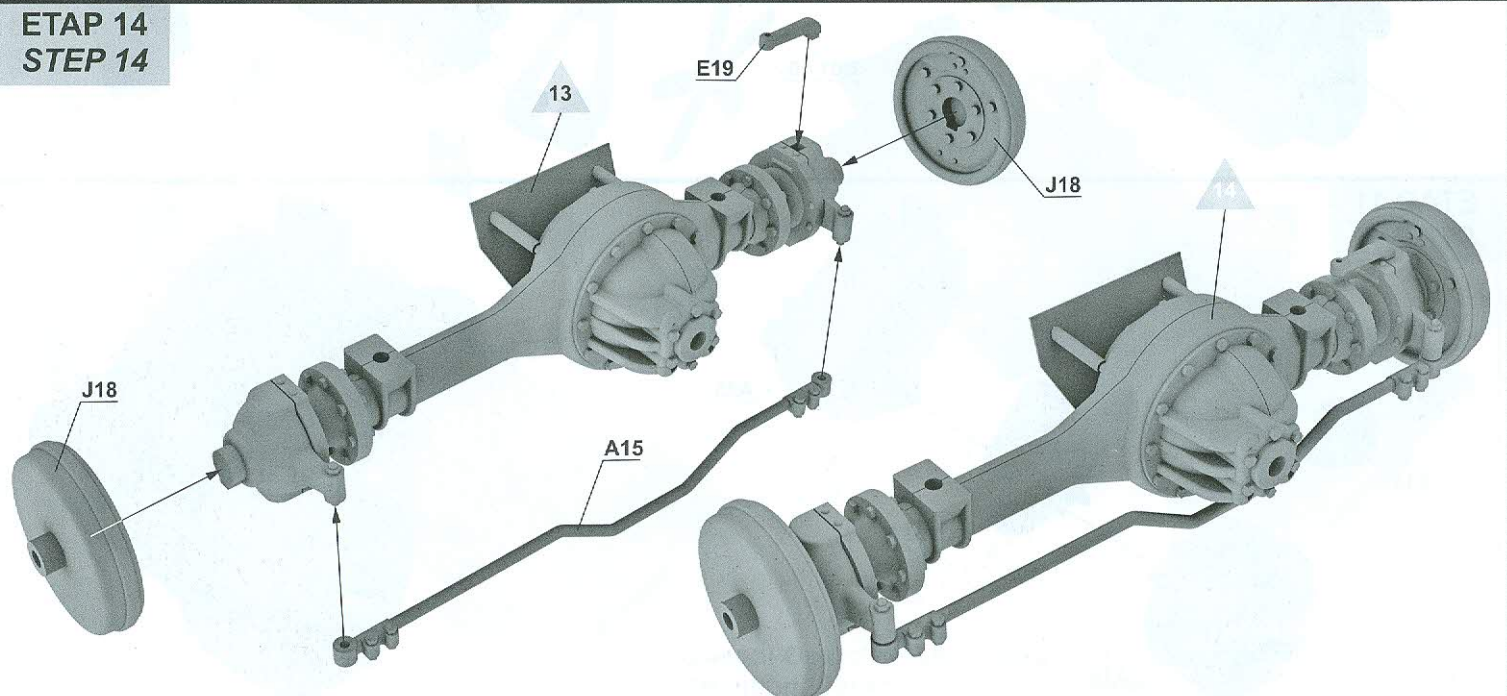



**ETAP 15**  
**STEP 15**

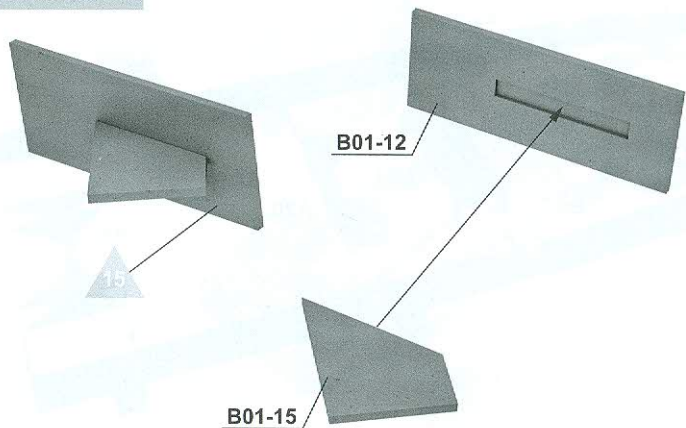

**ETAP 16**  
**STEP 16**

wykonać x2  
make x2

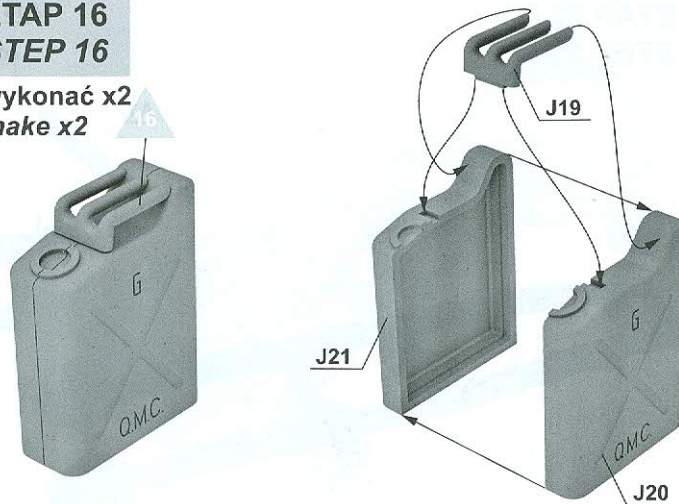

**ETAP 17**  
**STEP 17**

drugi wykonać jako lustrzane odbicie  
make second as mirror

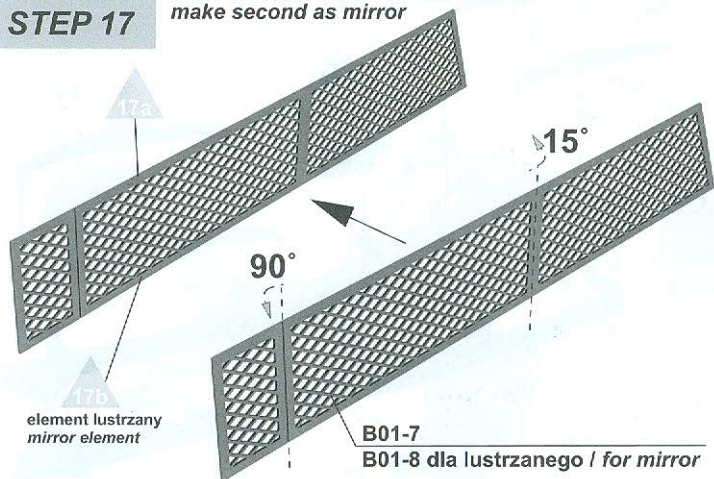

**ETAP 18**  
**STEP 18**

drugi wykonać jako lustrzane odbicie  
make second as mirror

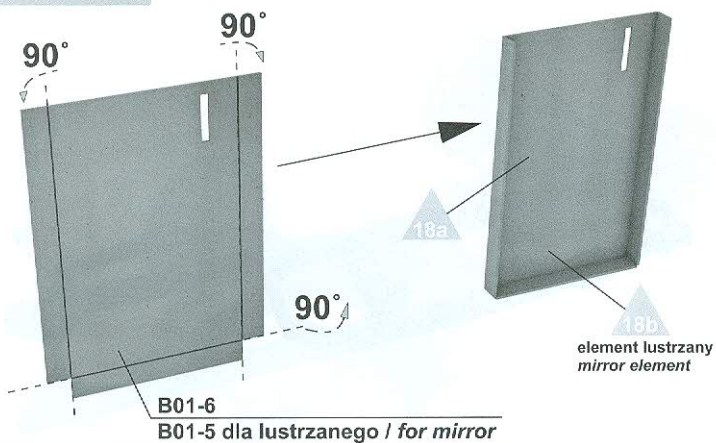

**ETAP 19**  
**STEP 19**

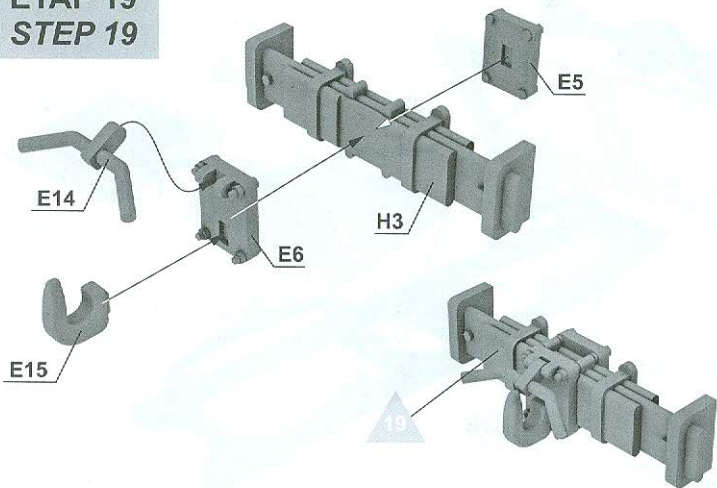

**ETAP 20**  
**STEP 20**

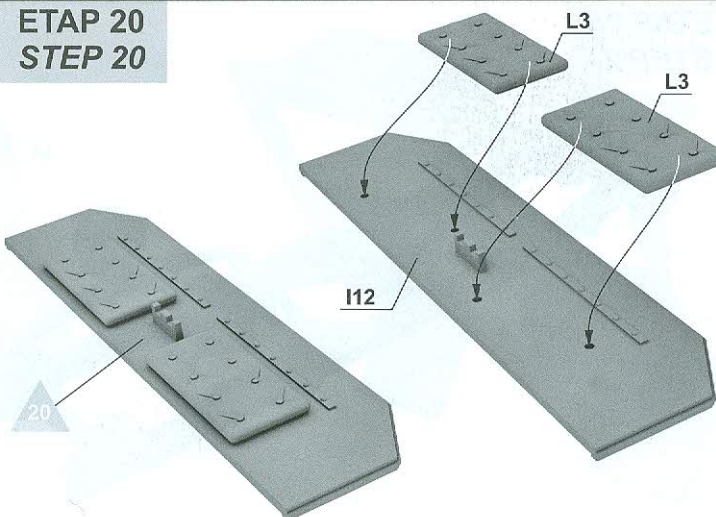

**ETAP 21**  
**STEP 21**

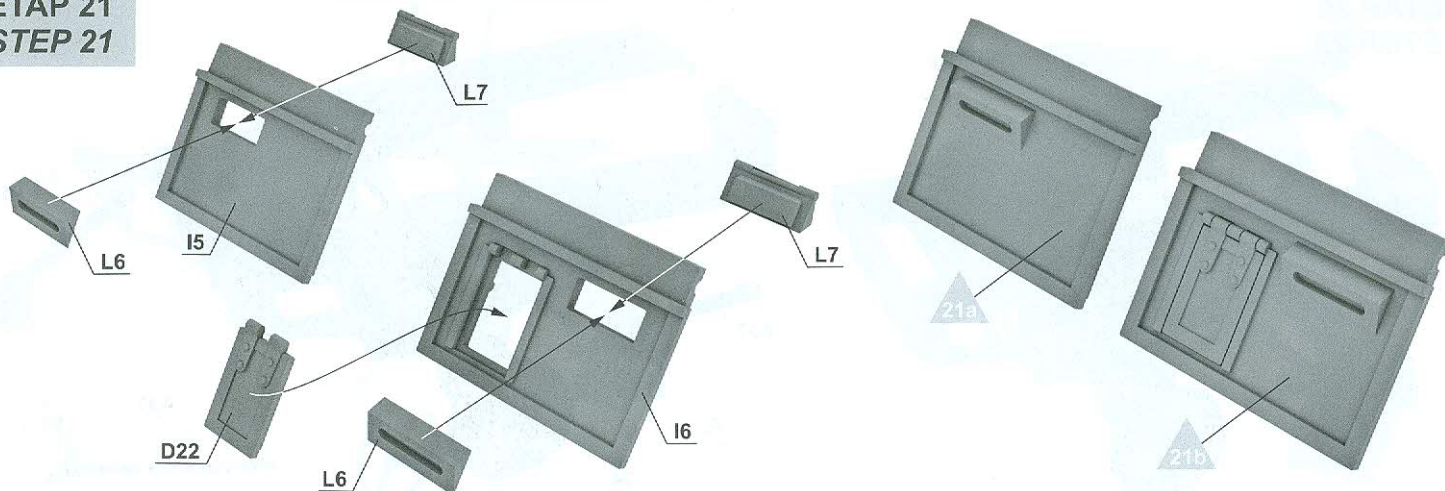

ETAP 22  
STEP 22

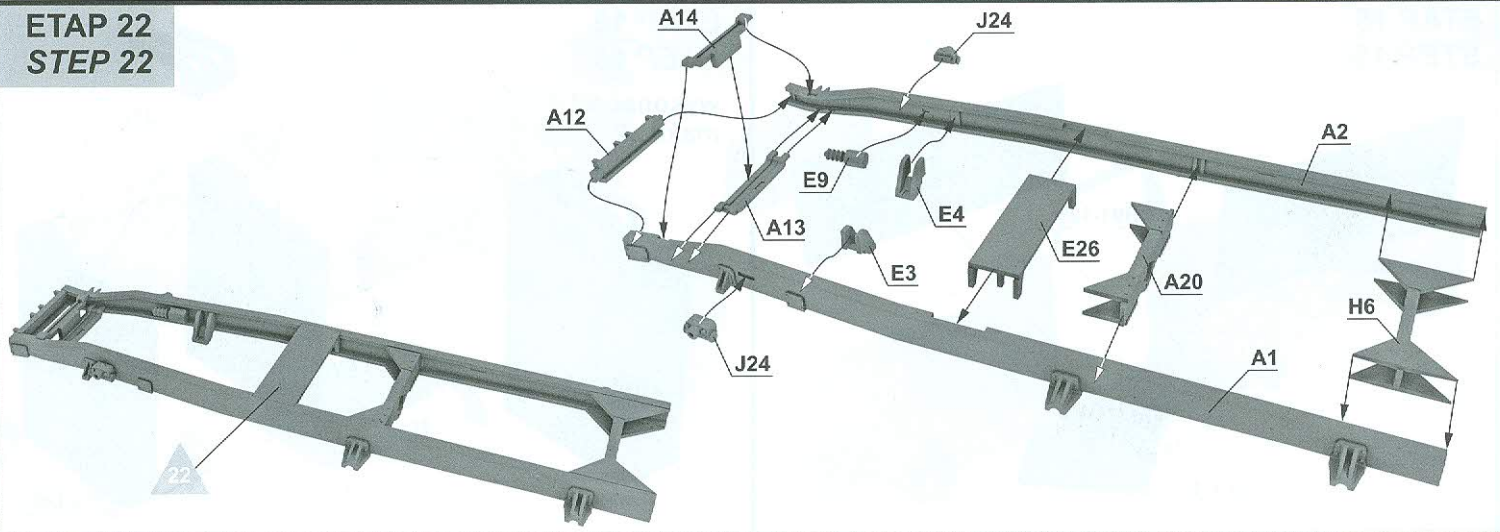

ETAP 23  
STEP 23

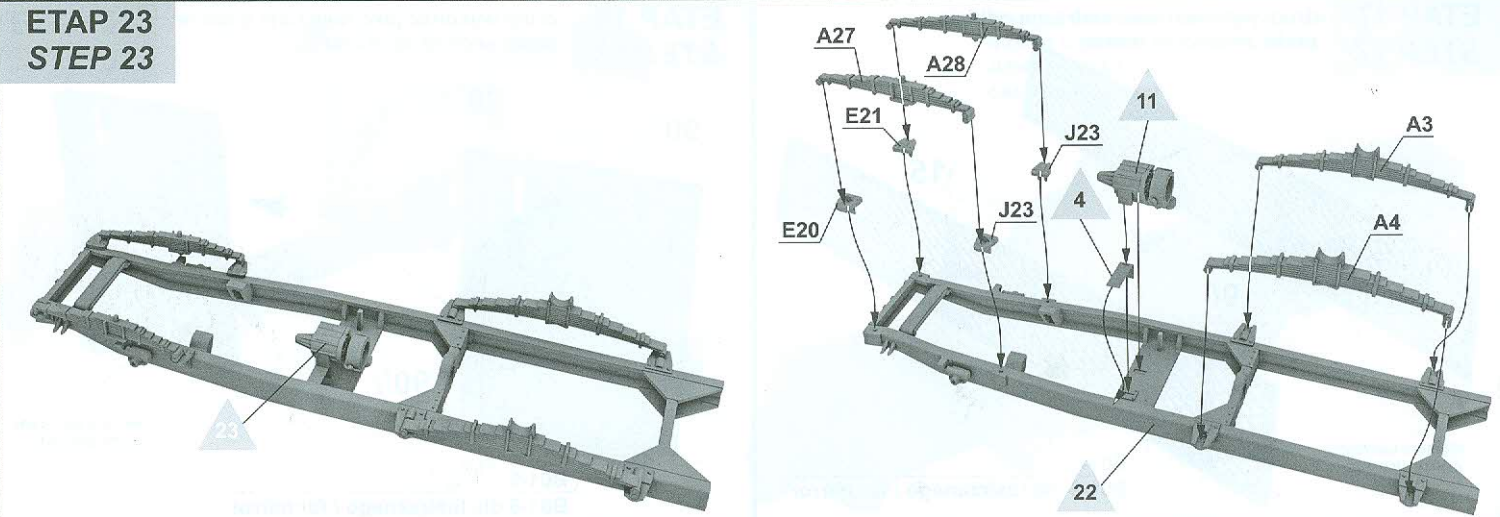

ETAP 24  
STEP 24

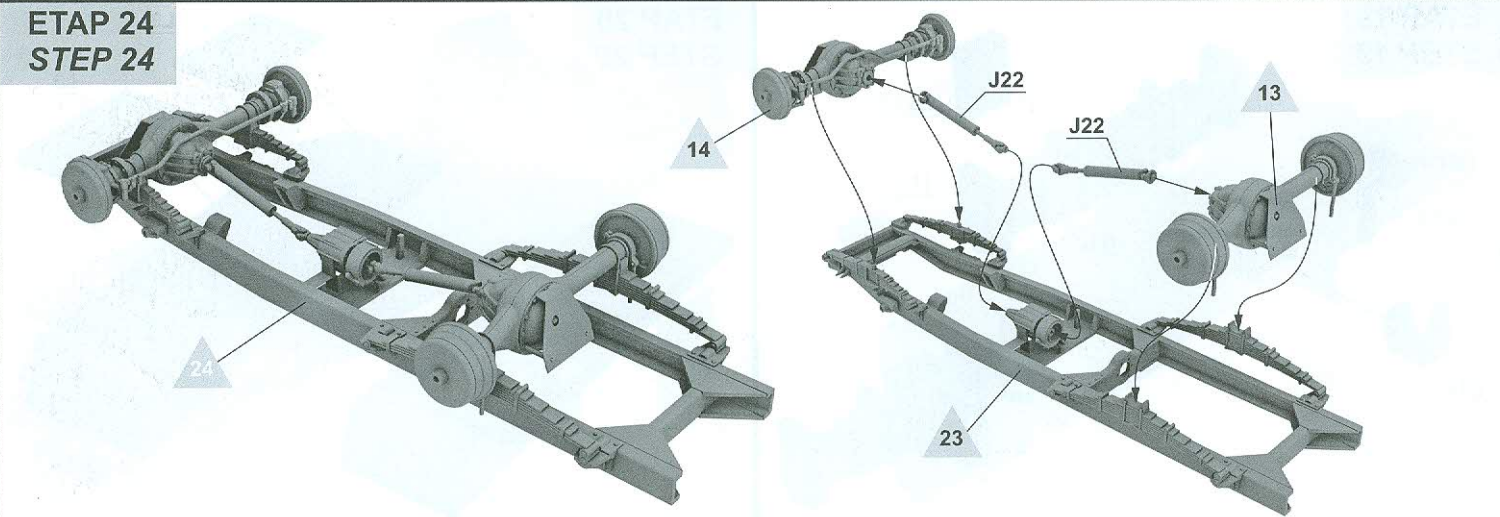

ETAP 25  
STEP 25

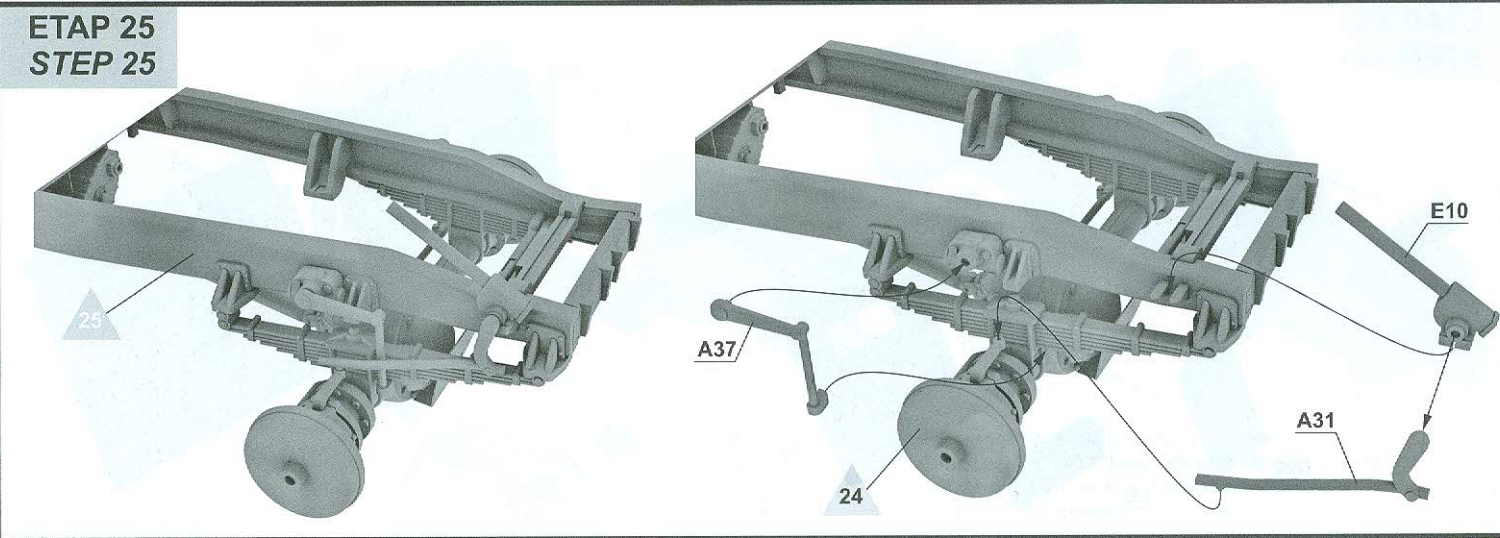

**ETAP 26**  
**STEP 26**

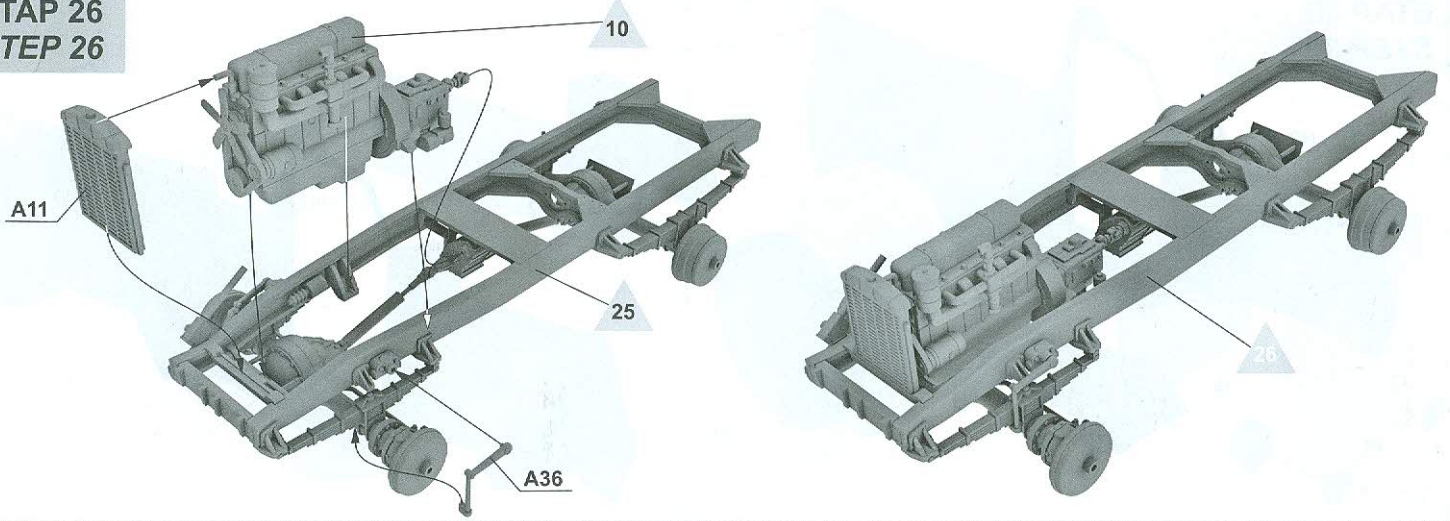

**ETAP 27**  
**STEP 27**

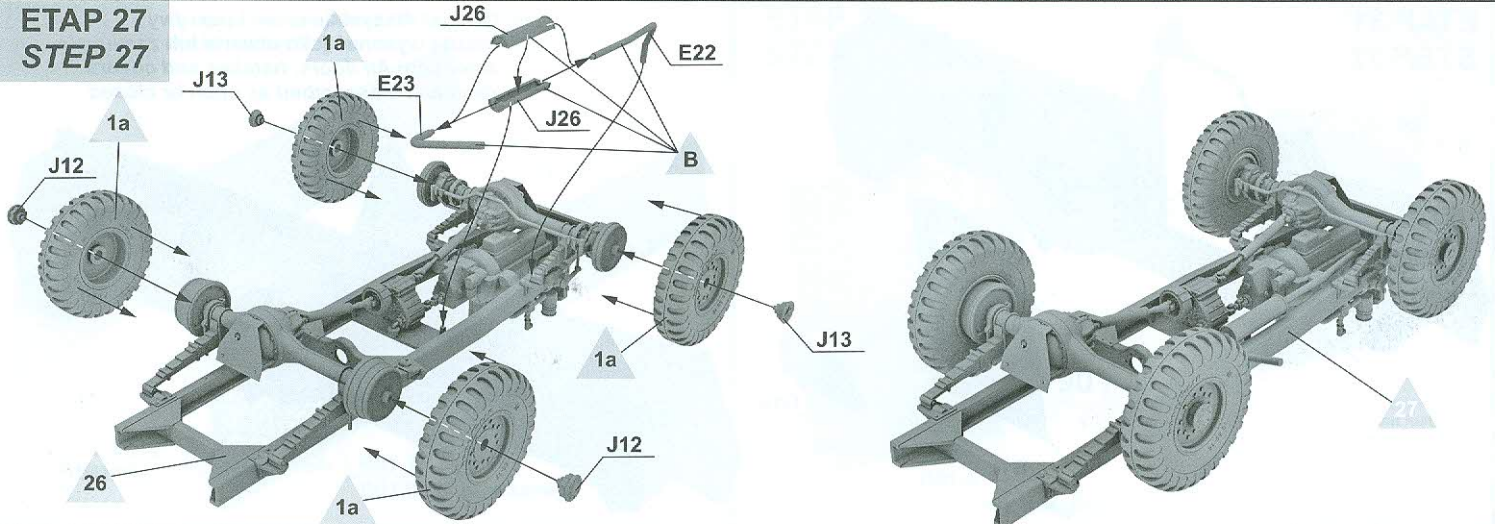

**ETAP 28**  
**STEP 28**

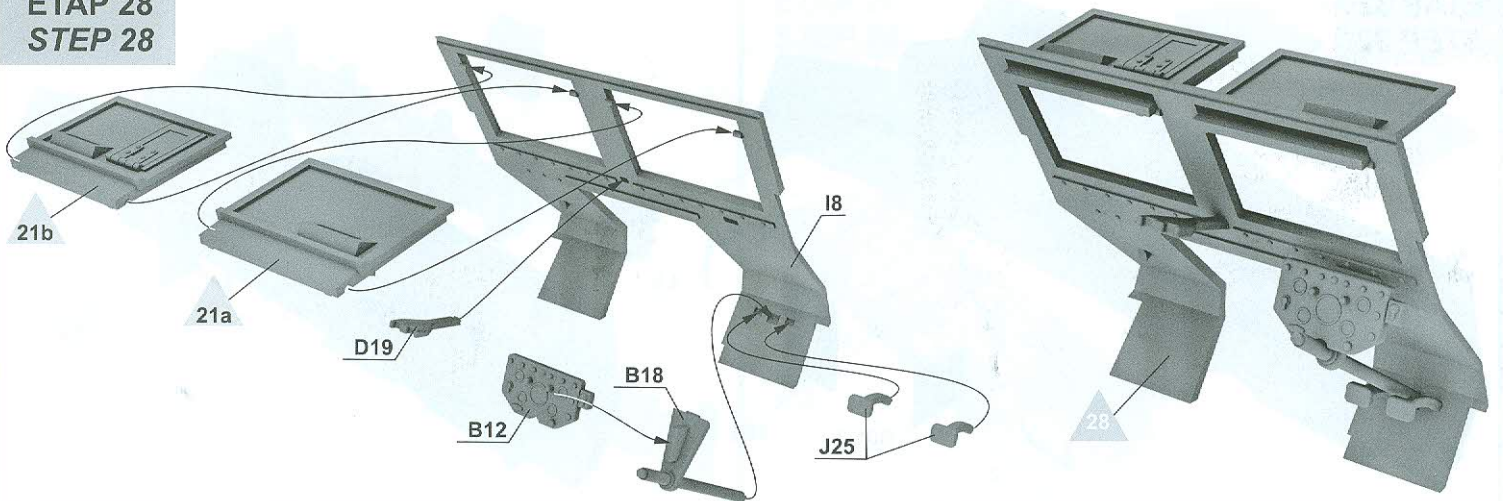

**ETAP 29**  
**STEP 29**

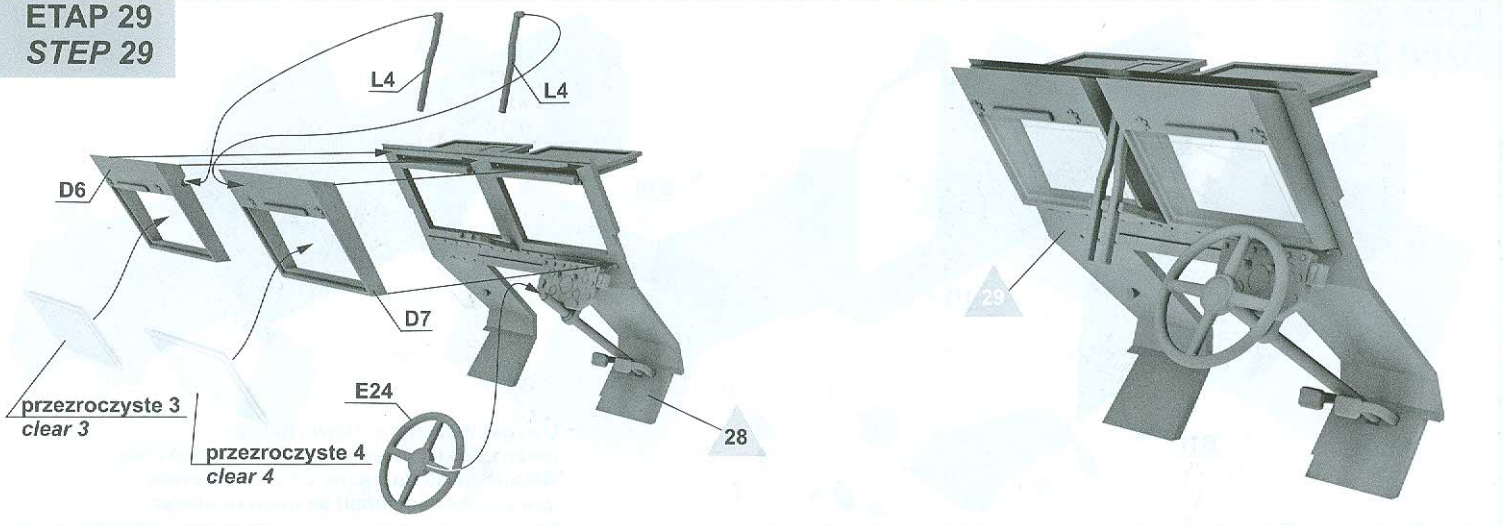

**ETAP 30  
STEP 30**

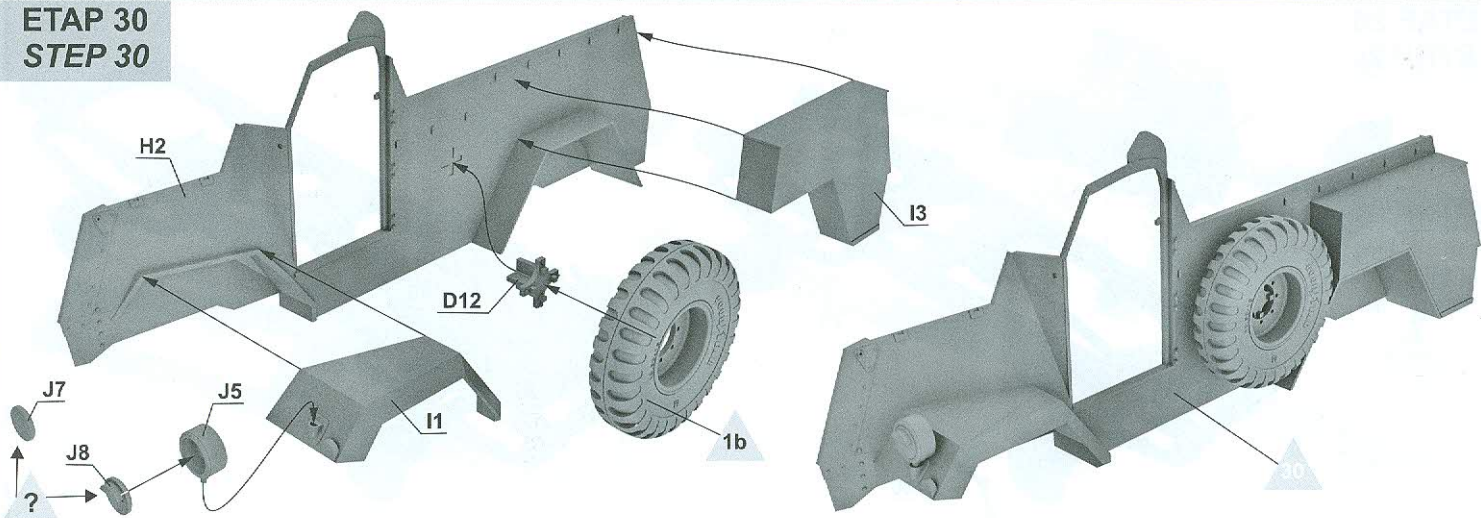

**ETAP 31  
STEP 31**

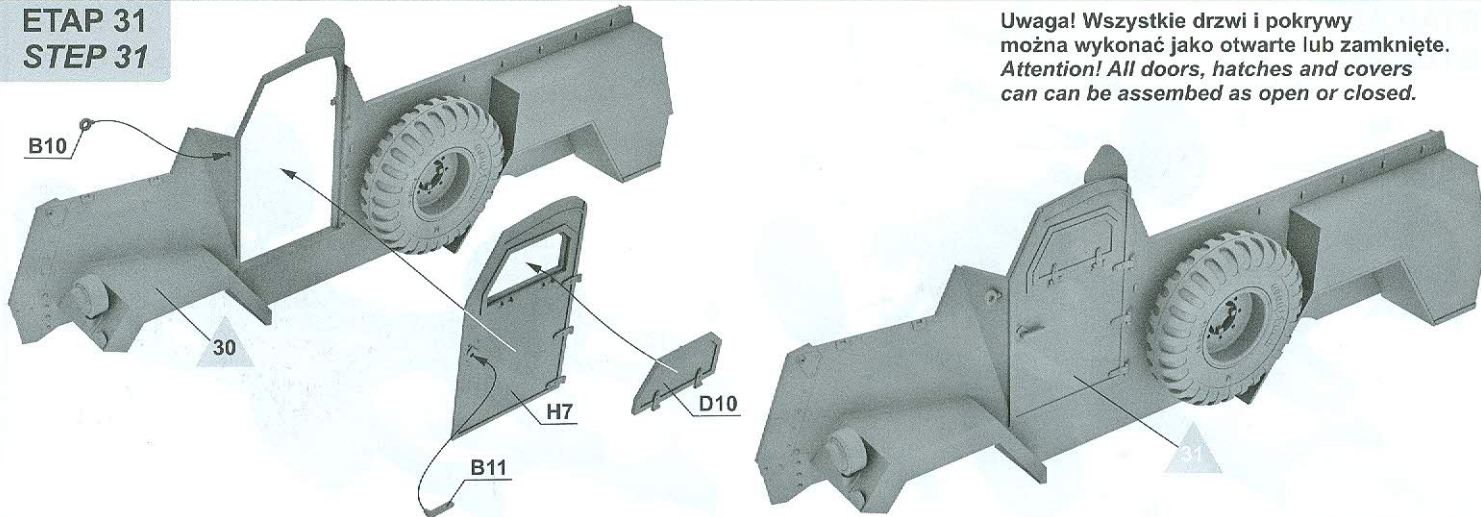

**Uwaga! Wszystkie drzwi i pokrywy można wykonać jako otwarte lub zamknięte.  
Attention! All doors, hatches and covers can be assembled as open or closed.**

**ETAP 32  
STEP 32**

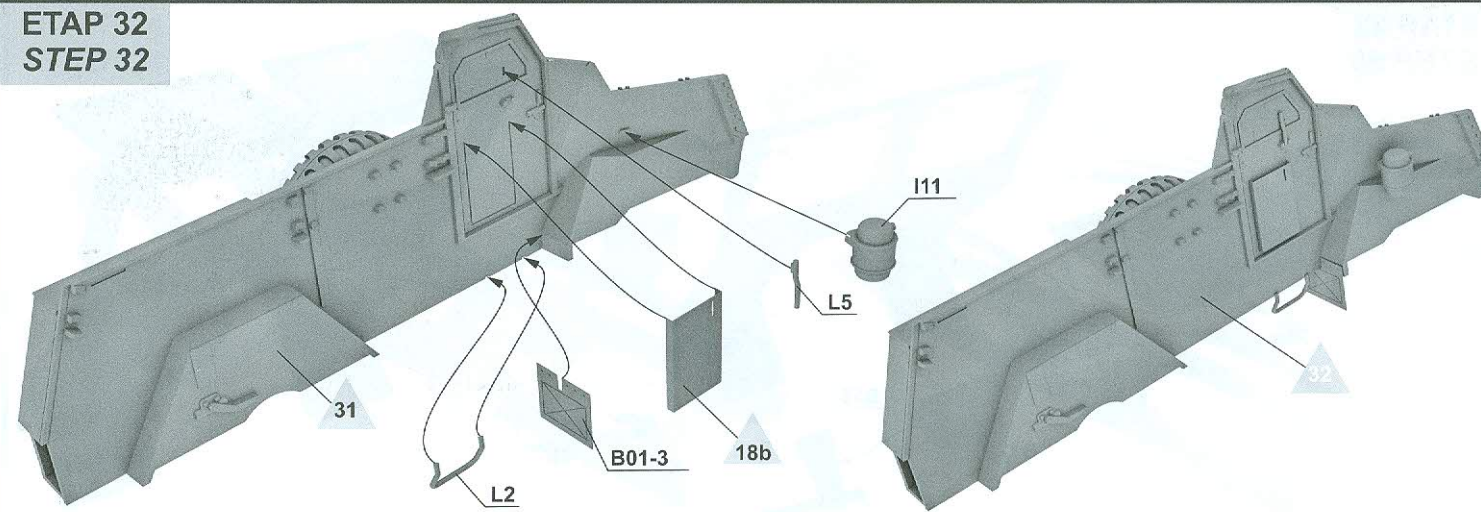

**ETAP 33  
STEP 33**

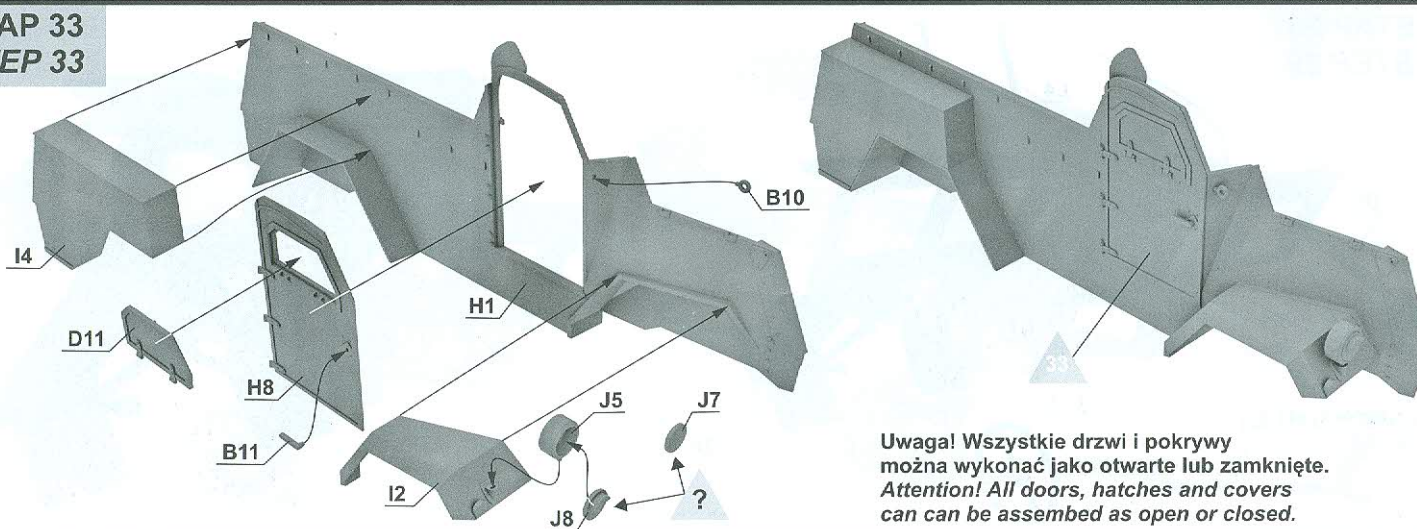

**Uwaga! Wszystkie drzwi i pokrywy można wykonać jako otwarte lub zamknięte.  
Attention! All doors, hatches and covers can be assembled as open or closed.**

**ETAP 34**  
**STEP 34**

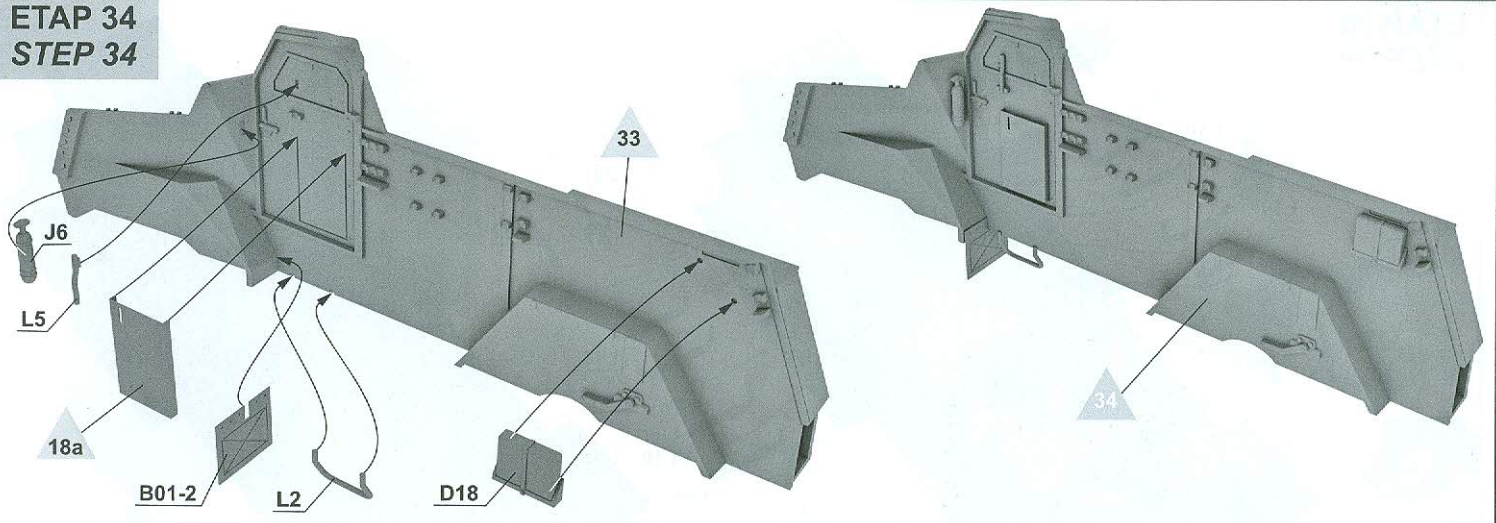

**ETAP 35**  
**STEP 35**

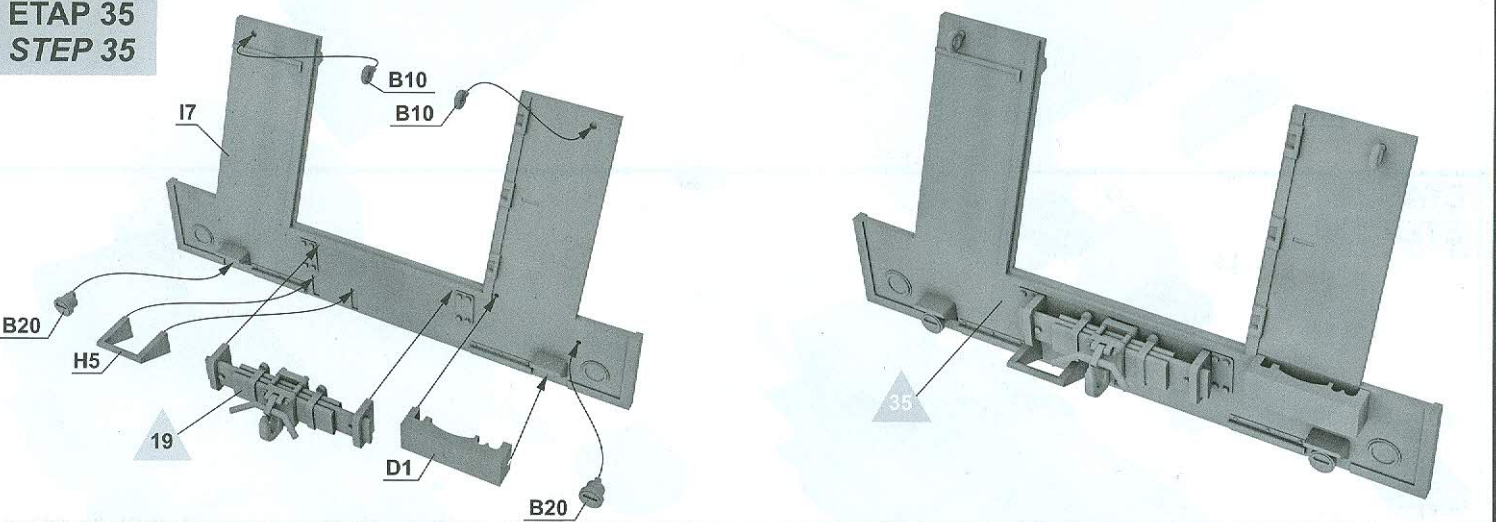

**ETAP 36**  
**STEP 36**

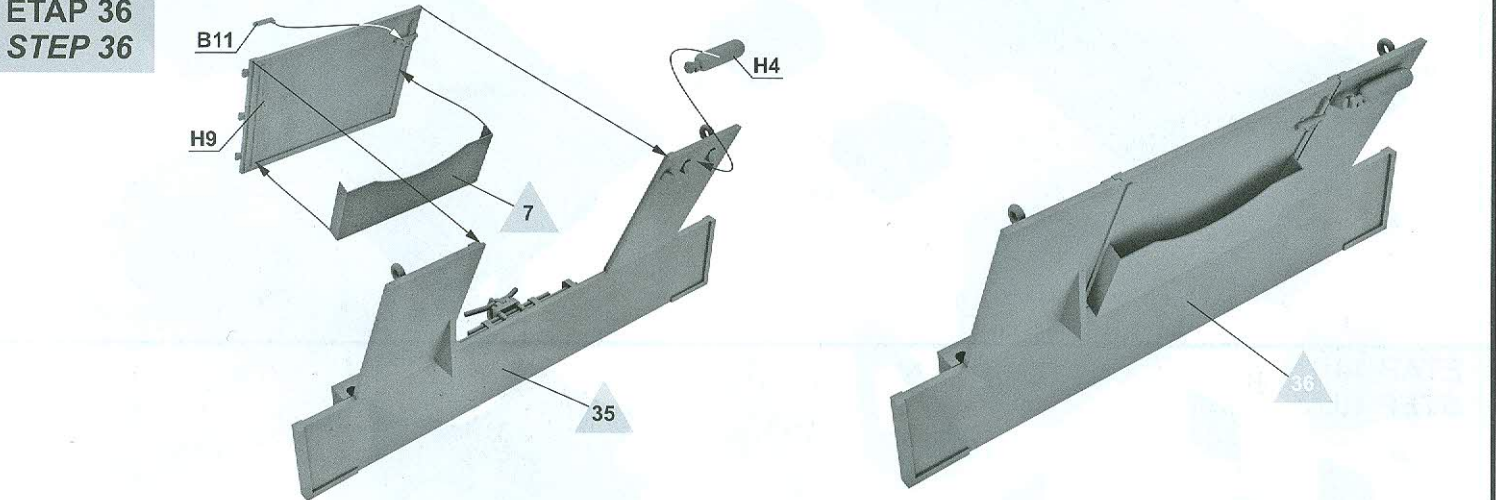

**ETAP 37**  
**STEP 37**

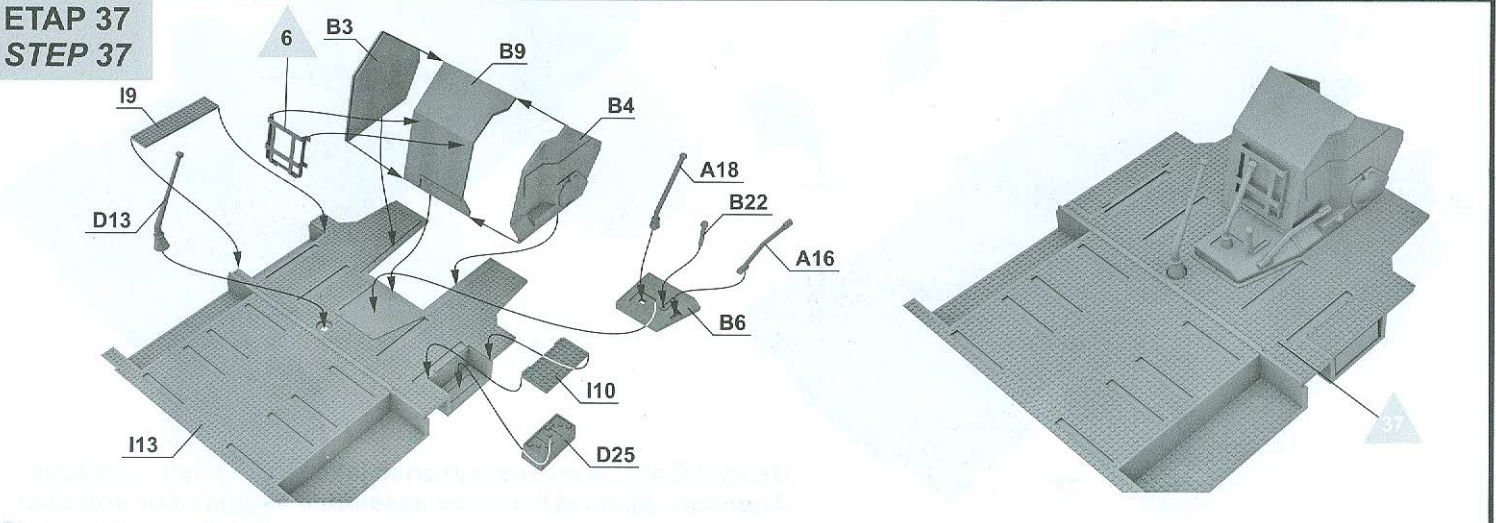

**ETAP 38**  
**STEP 38**

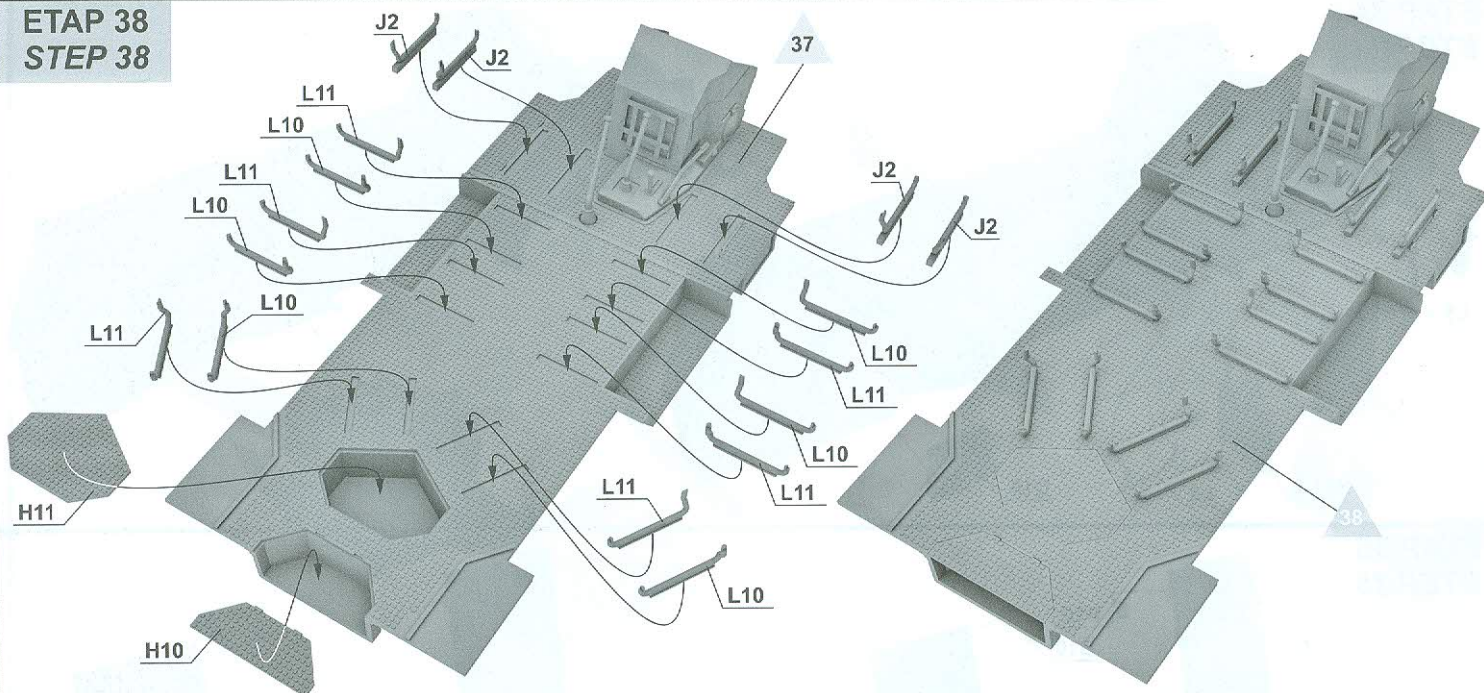

**ETAP 39**  
**STEP 39**

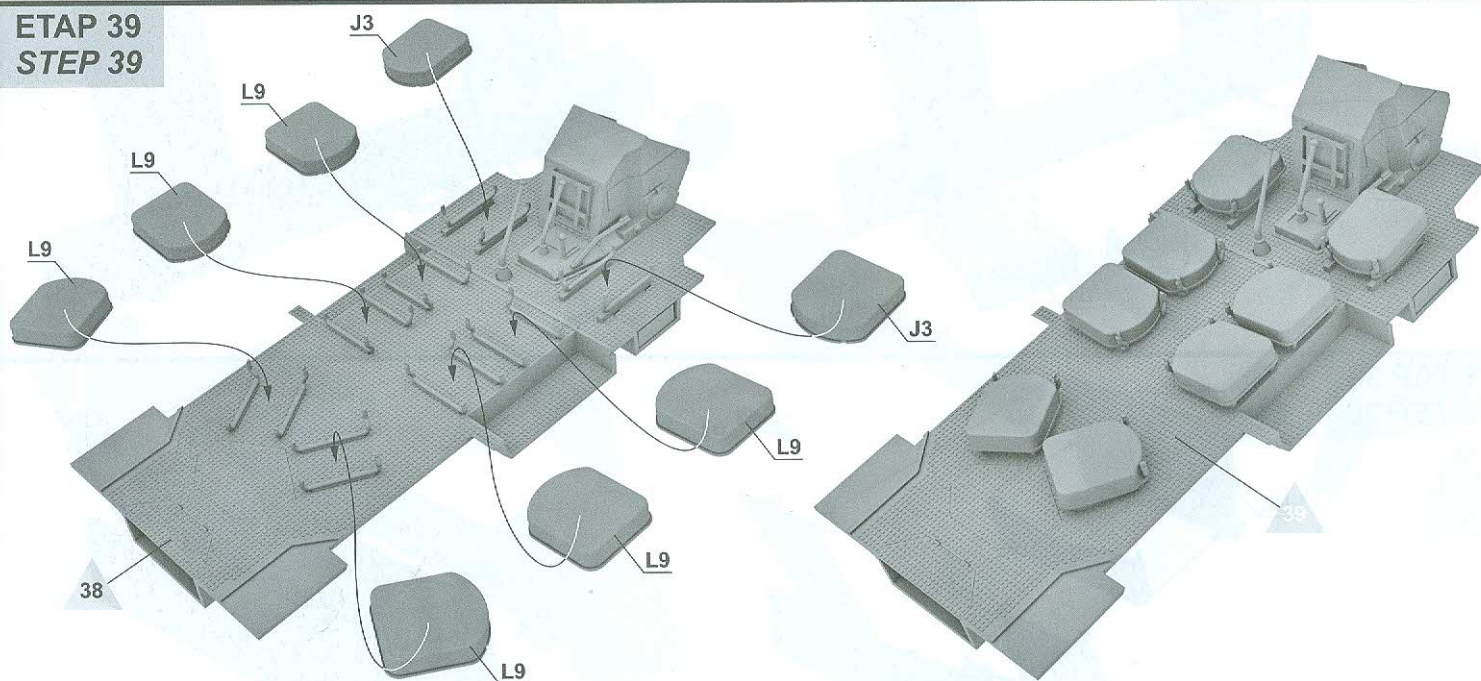

**ETAP 40**  
**STEP 40**

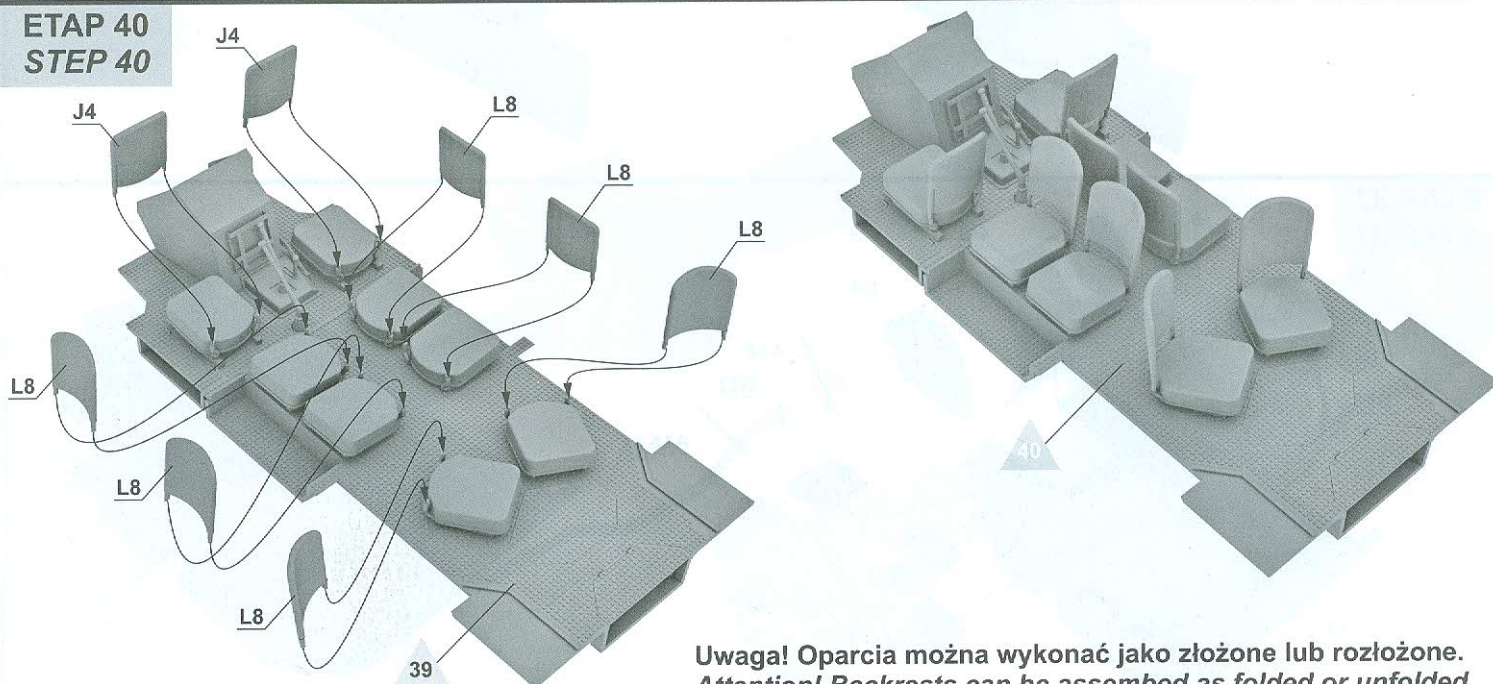

**Uwaga! Oparcia można wykonać jako złożone lub rozłożone.**  
**Attention! Backrests can be assembled as folded or unfolded.**

**ETAP 41  
STEP 41**

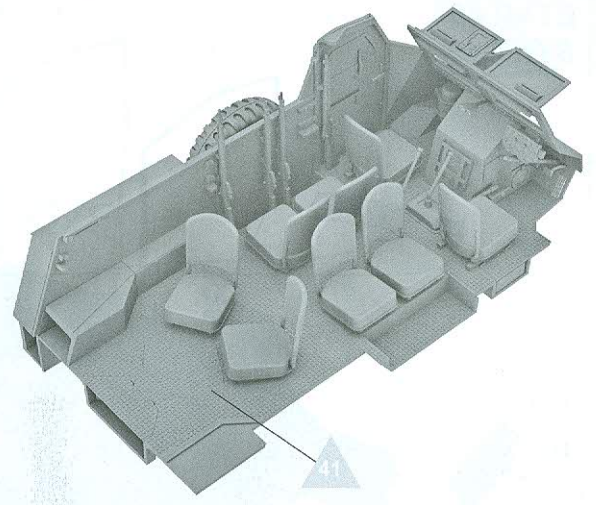
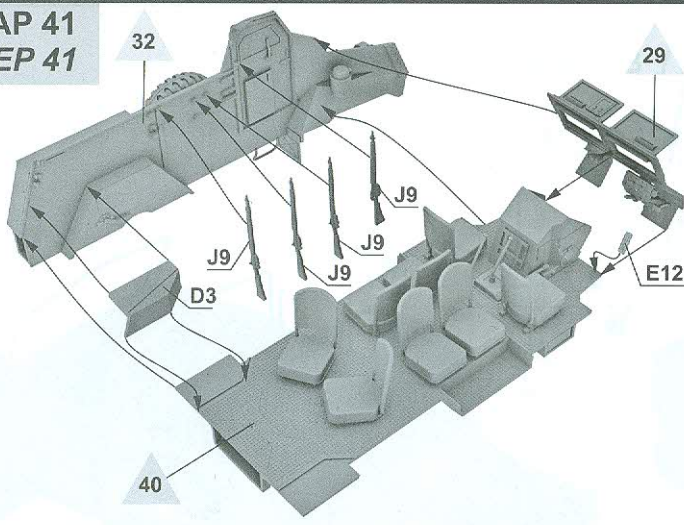

**ETAP 42  
STEP 42**

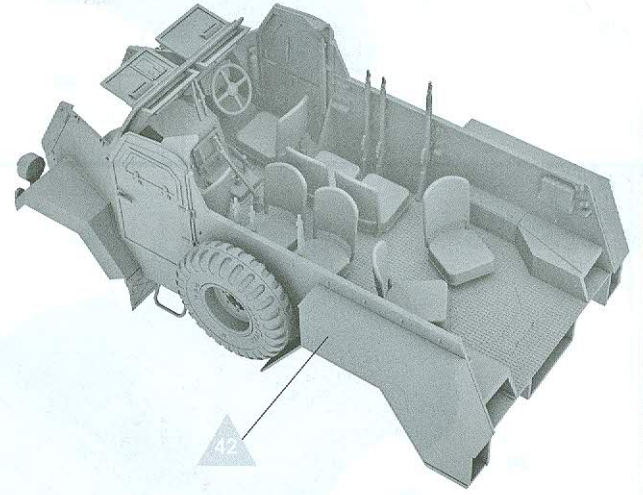
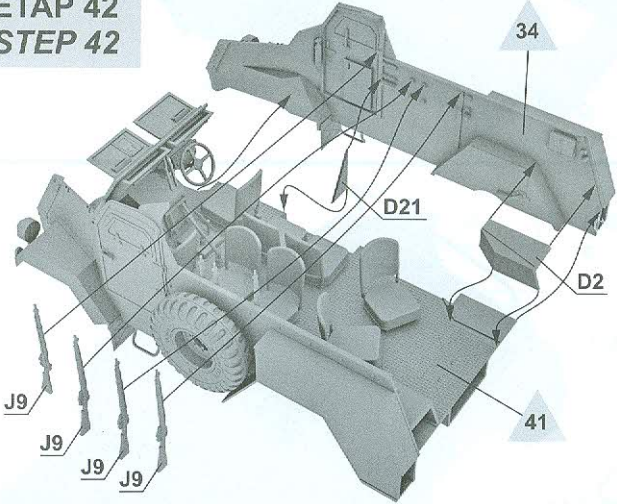

**ETAP 43  
STEP 43**

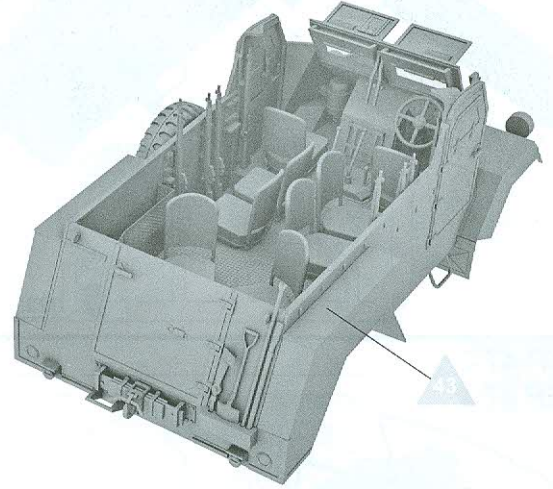
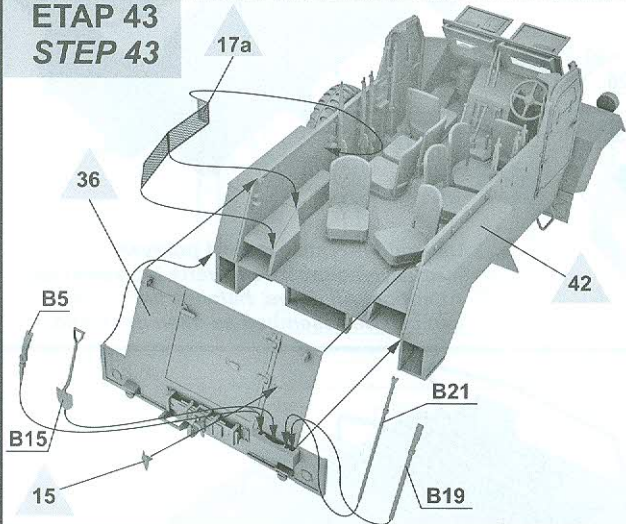

**ETAP 44  
STEP 44**

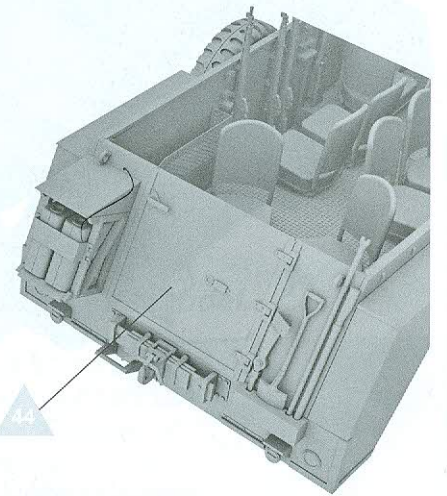
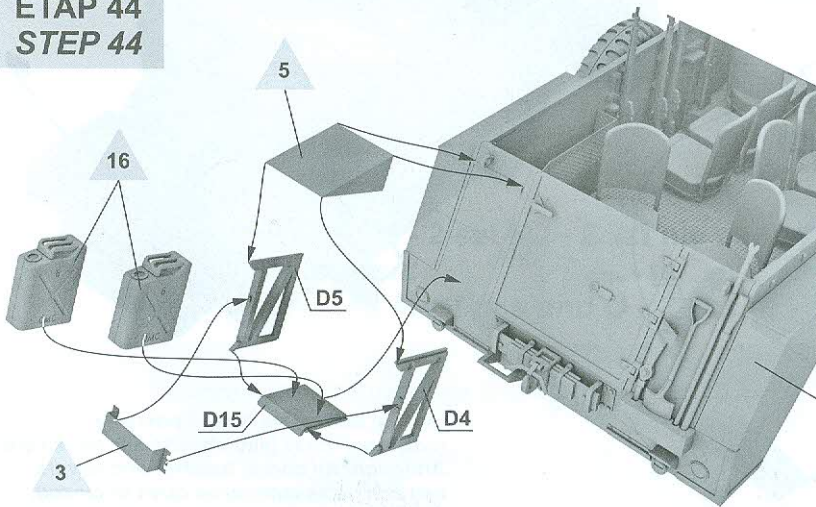

**ETAP 45  
STEP 45**

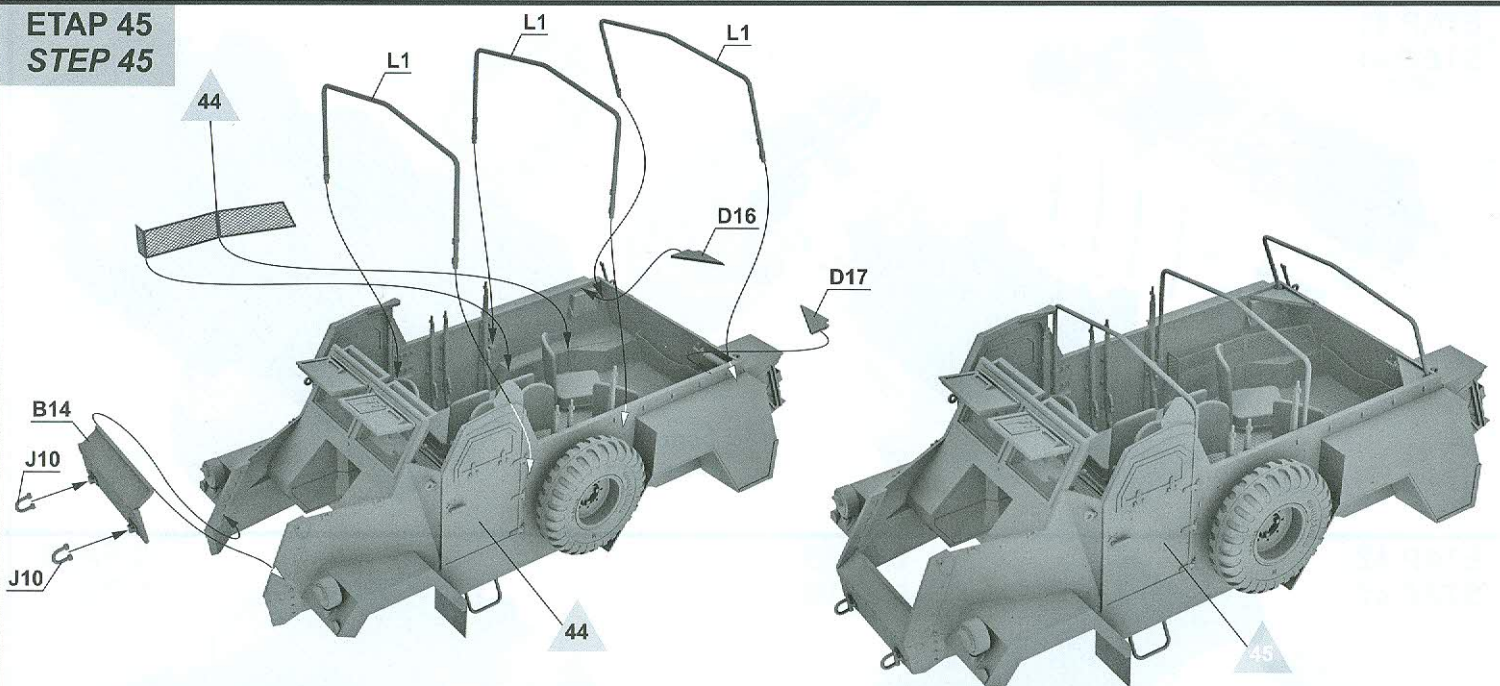

**ETAP 46  
STEP 46**

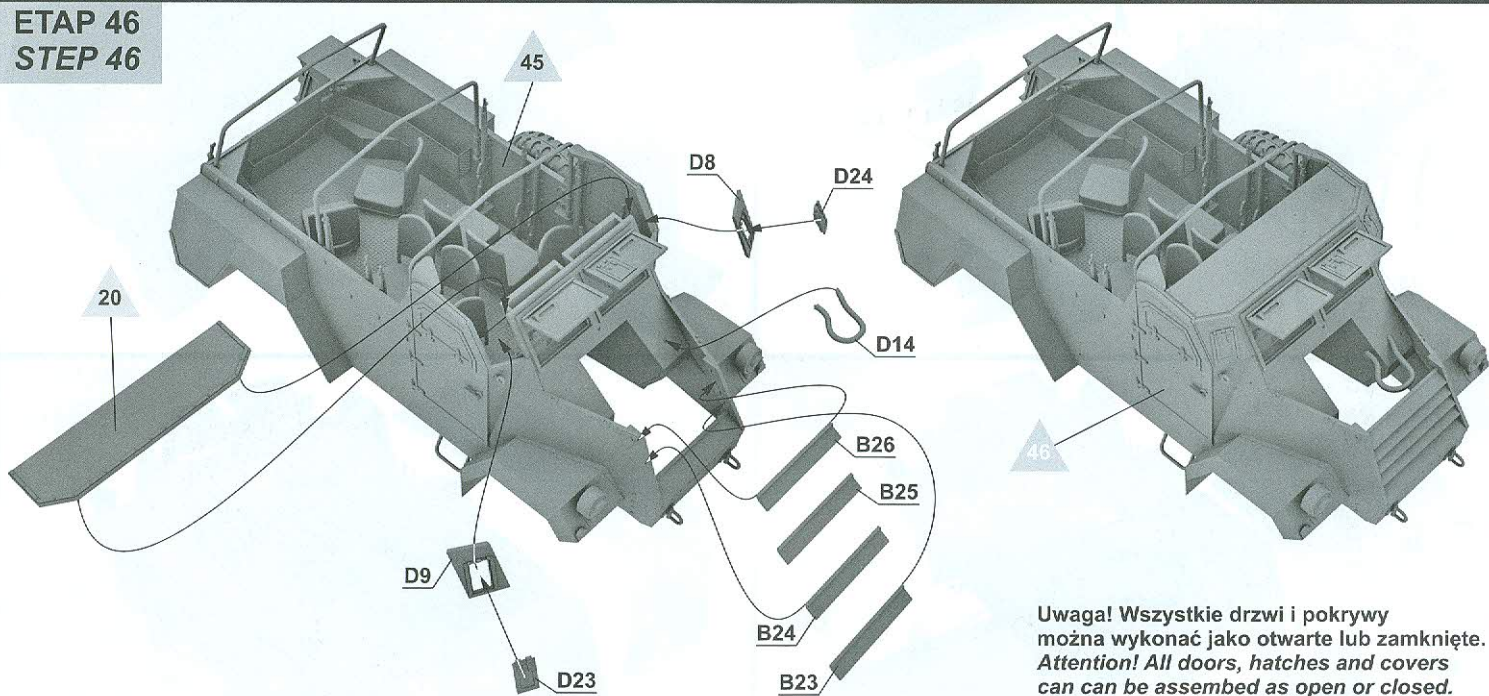

**Uwaga! Wszystkie drzwi i pokrywy można wykonać jako otwarte lub zamknięte.  
Attention! All doors, hatches and covers can be assembled as open or closed.**

**ETAP 47  
STEP 47**

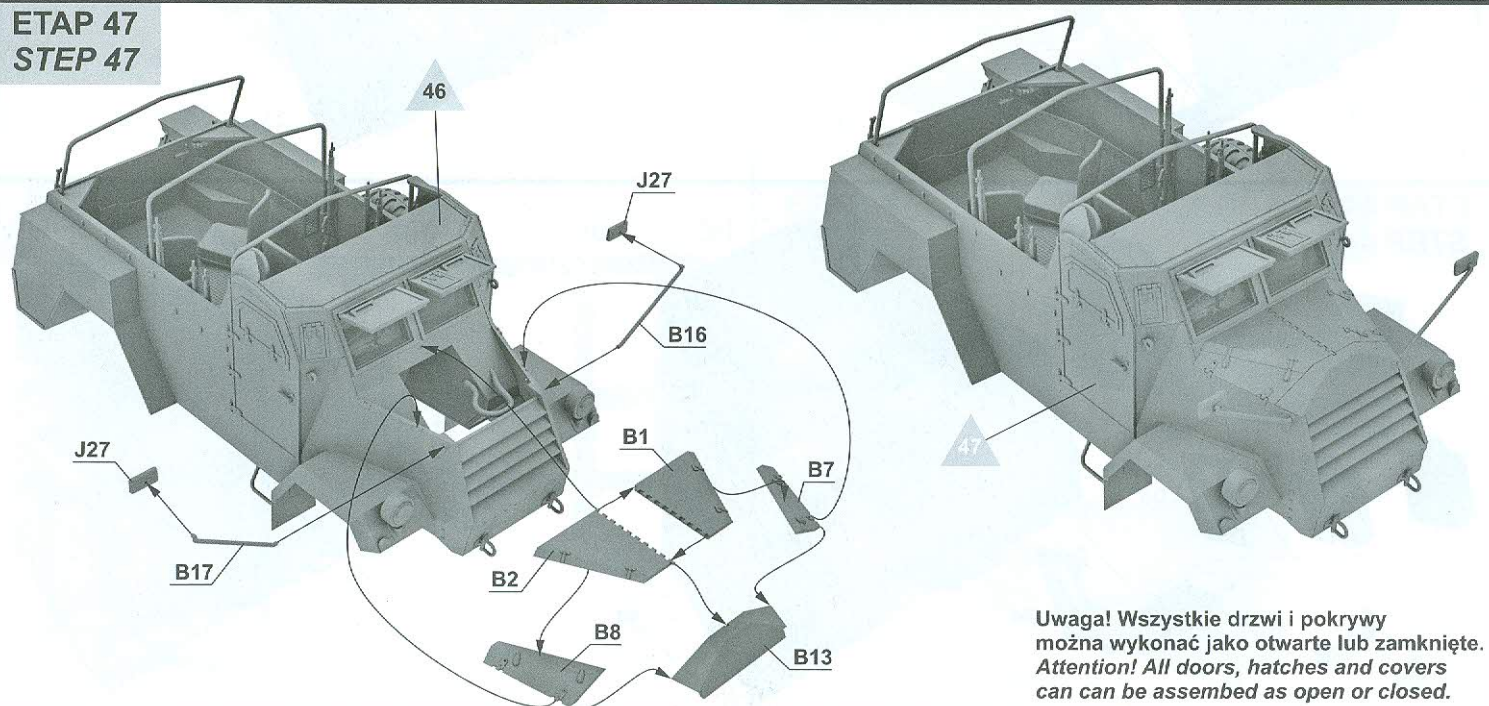

**Uwaga! Wszystkie drzwi i pokrywy można wykonać jako otwarte lub zamknięte.  
Attention! All doors, hatches and covers can be assembled as open or closed.**



**ETAP 48**  
**STEP 48**

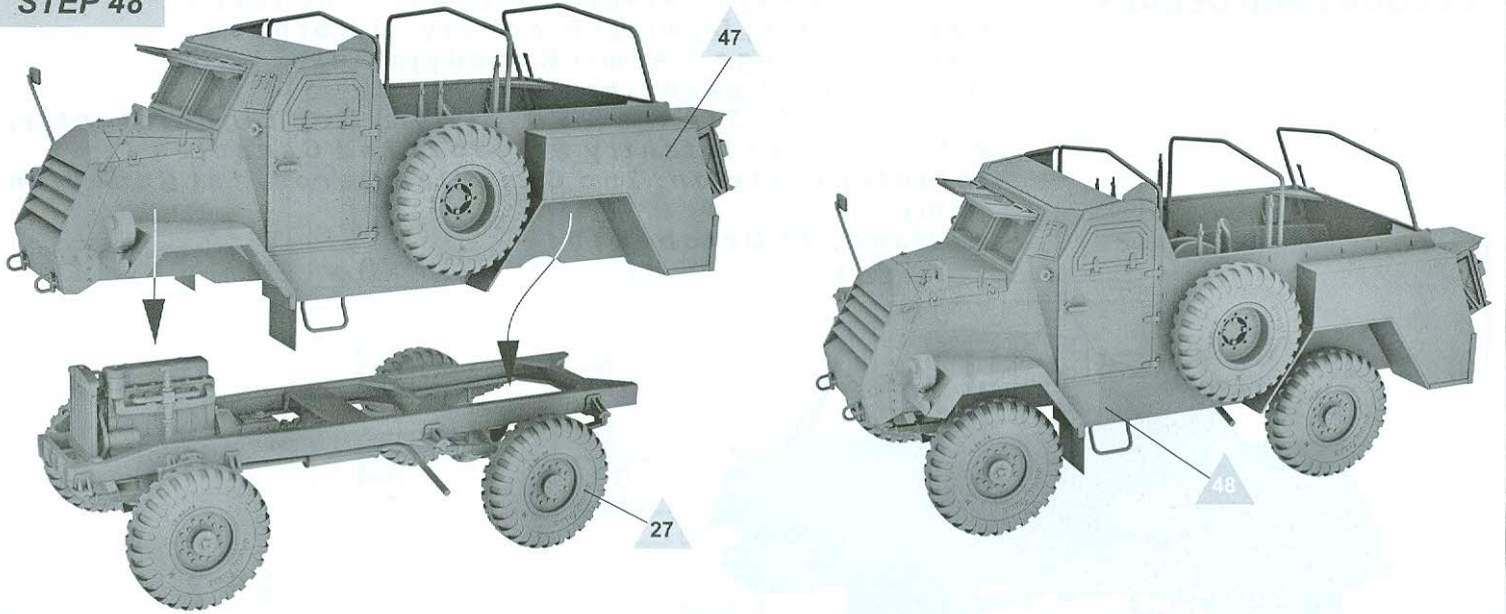

**WYKONANY MODEL**  
**FINISHED MODEL**

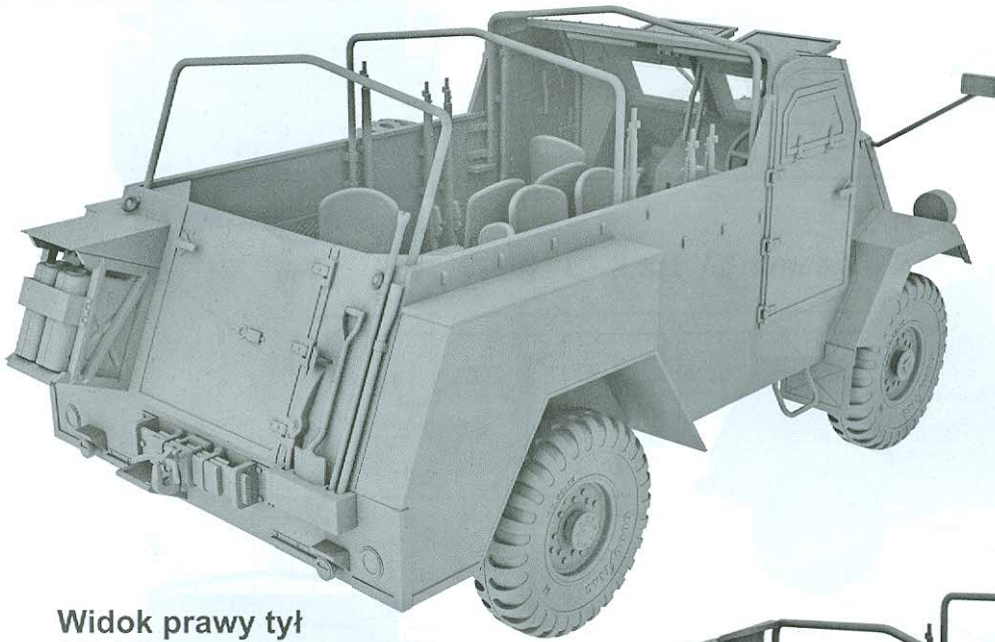

**Widok prawy tył**  
**Right rear view.**

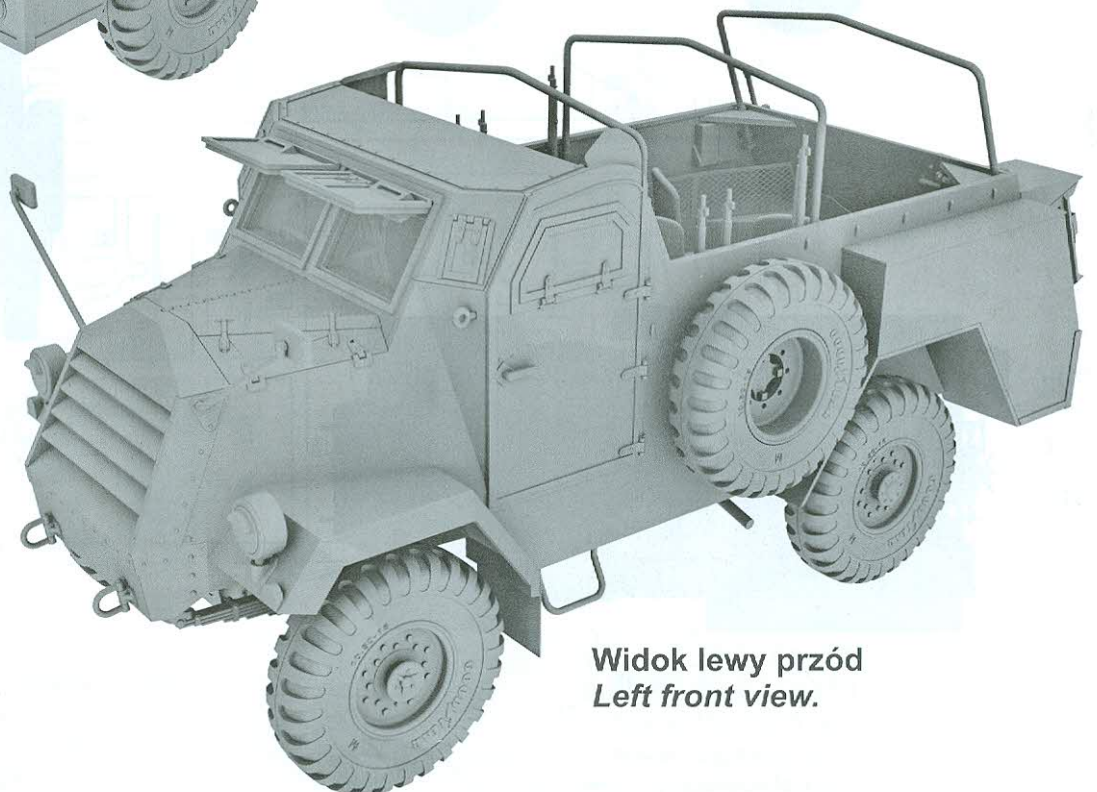

**Widok lewy przód**  
**Left front view.**

**MALOWANIE I KALKOMANIE**  
**COLOURS AND DECALS**

**Chevrolet C15TA z Pułku Royal Hamilton Light Infantry 4 Kanadyjskiej Brygady Piechoty 2 Kanadyjskiej Dywizji Piechoty, II Korpusu Kanadyjskiego 1 Armii Kanadyjskiej Holandia, 27 października 1944**  
*Chevrolet C15TA from Royal Hamilton Light Infantry, 4th Canadian Infantry Brigade, 2nd Canadian Infantry Division, 2nd Canadian Corps, 1st Canadian Army Holland, 27 October 1944*

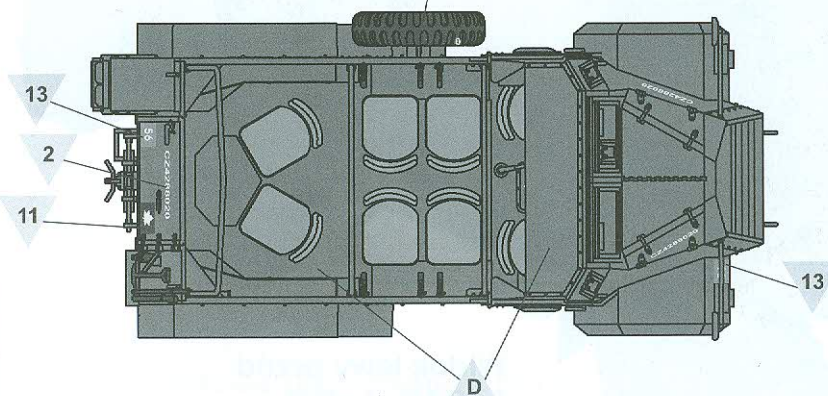
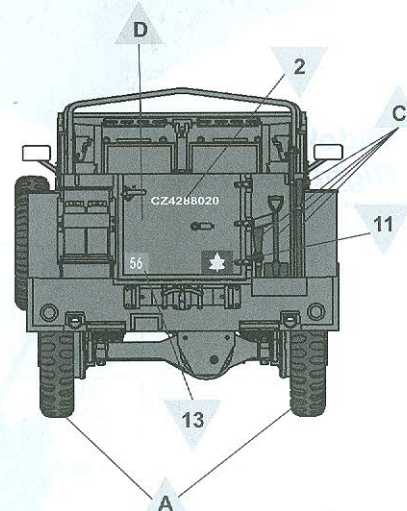
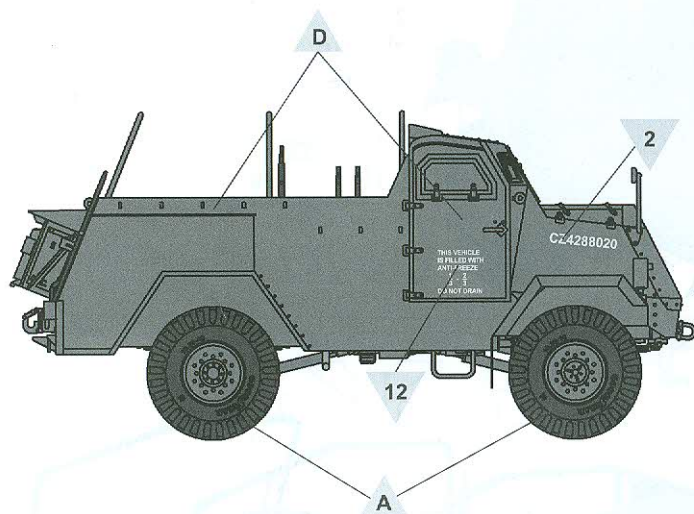
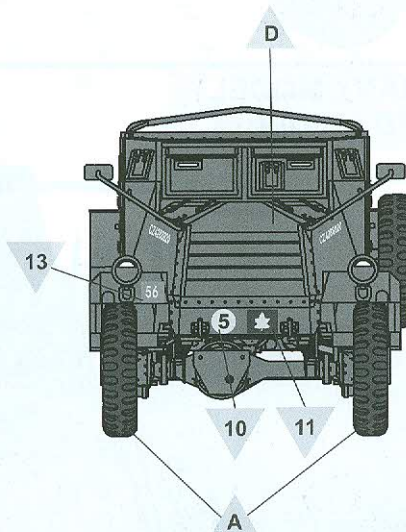
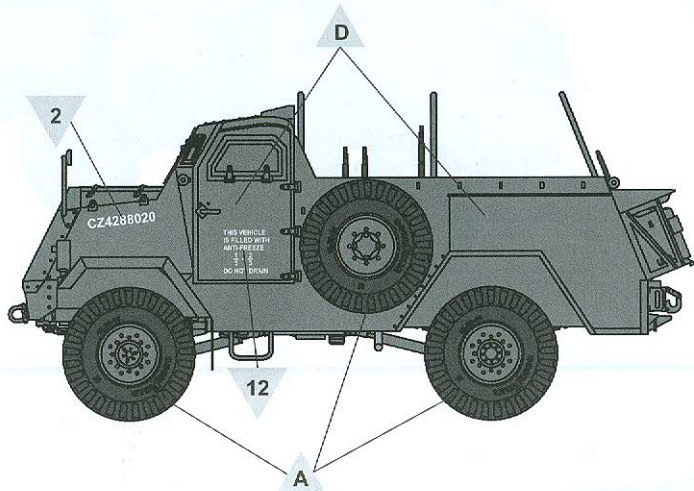

**MALOWANIE I KALKOMANIE**  
**COLOURS AND DECALS**

**Chevrolet C15TA z 10 Pułku Pancernego (The Fort Garry Horse) 2 Kanadyjskiej Brygady Pancerniej Francja, Normandia, czerwiec 1944**  
***Chevrolet C15TA from 10th Armoured Regiment (The Fort Garry Horse), 2nd Canadian Armoured Brigade France, Normandy, June 1944***

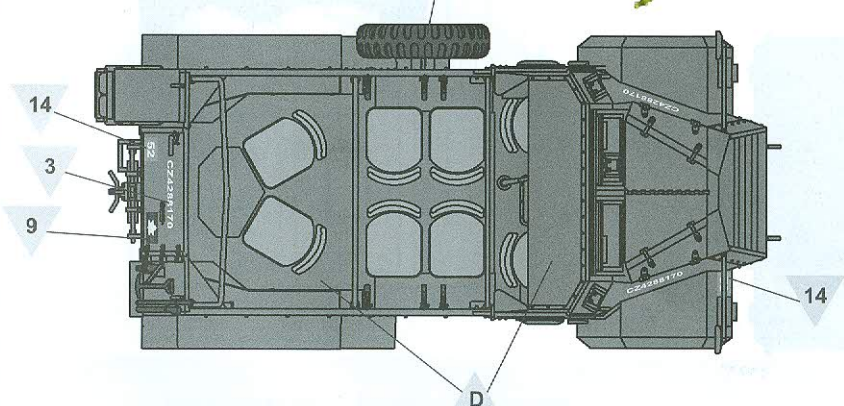
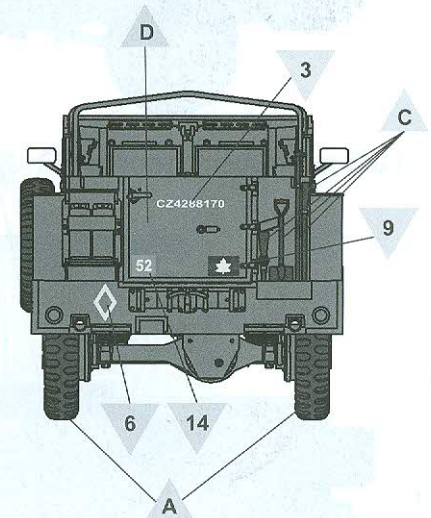
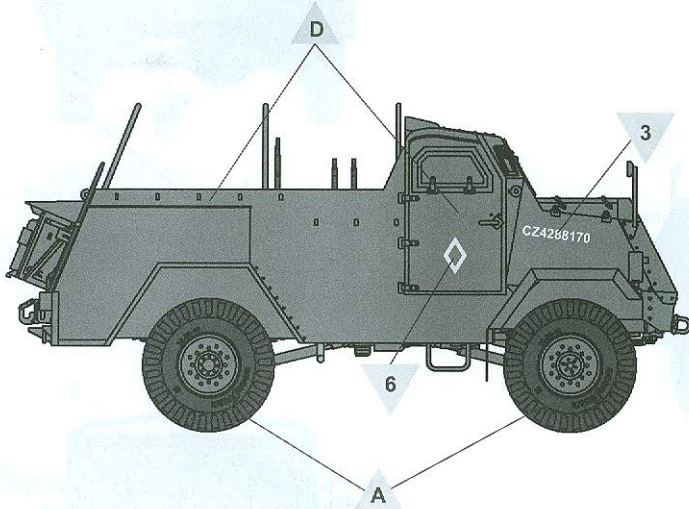
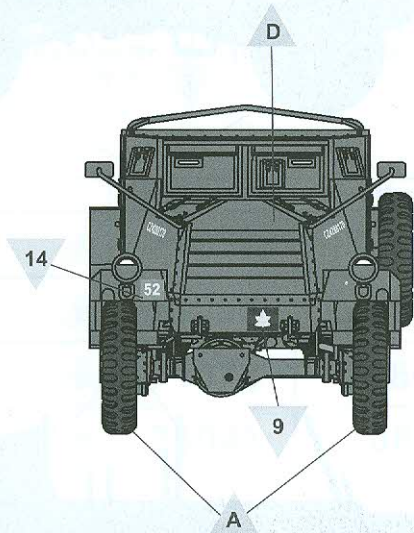
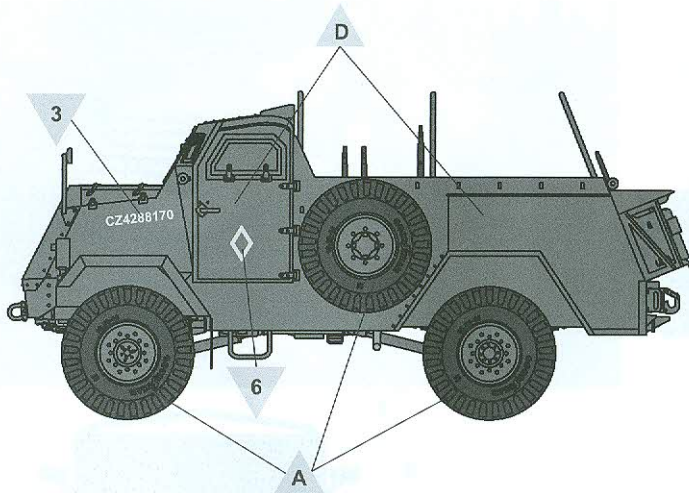

**MAŁOWANIE I KALKOMANIE**  
**COLOURS AND DECALS**

**Chevrolet C15TA z 1 Kanadyjskiego Pułku  
Samochodów Pancernych 31 Brygady Czołgów  
79 Dywizji Pancerniej**

**Holandia, wrzesień 1944**

***Chevrolet C15TA from 1st Canadian Armoured Carrier  
Regiment, 31st Tank Brigade, 79th Armoured Division  
Holland, September 1944***

