

# BOEING 707-300 B



80452

**F**

C'est en 1950 que la firme BOEING commença l'étude d'un quadrimoteur à vocation civile et militaire. Le prototype fit son premier vol le 15 juillet 1954, et en septembre l'U.S. AIR FORCE passa une commande importante de ravitailleurs, le KC 135. Le 15 octobre, la PAN AMERICAN commanda six Boeing 707-121.

Par la suite, le Boeing 707 fut développé en parallèle aux versions C 135 militaires, pour donner les séries 200 fondamentalement différentes.

**CARACTERISTIQUES**

Longueur : 46,61 m  
 Envergure : 44,42 m  
 Hauteur : 12,94 m  
 Réacteurs : 4 Pratt & Whitney JT3D

**GB**

It was in 1950 that BOEING began studies on a four-engined aircraft for civilian and military use. The prototype took off on its maiden flight on the 15th July 1954, and in September, the US Air Force passed a large order for supply planes, the KC 135. On the 15th October, PAN AMERICAN ordered six BOEING 707-121s.

After this, the Boeing 707 was developed in parallel to the C.135 military versions, and this resulted in the 200 series, which was fundamentally different.

**SPECIFICATIONS**

Length : 46.61 m  
 Wingspan : 44.42 m  
 Height : 12.94 m  
 Engines : 4 Pratt & Whitney JT3D

**D**

Im Jahre 1950 begann die Firma BOEING die Studien zu einer viermotorigen Düsenmaschine zu zivilen und militärischen Zwecken. Der Prototyp unternahm seinen ersten Flug am 15. Juli 1954, und im September gab die U.S. AIR FORCE eine grosse Bestellung für Versorgungsflugzeuge vom Typ KC 135 auf. Am 15. Oktober bestellte die PAN AMERICAN sechs - BOEING 707-121.

In der Folgezeit wurde die BOEING 707 parallel zu den militärischen C. 135-Ausführungen entwickelt, die in die grundverschiedenen 200-Serien mündeten.

**TECHNISCHE DATEN**

Länge : 46,61 m  
 Spannweite : 44,42 m  
 Höhe : 12,94 m  
 Triebwerke : 4 Pratt & Whitney JT3D

**E**

En 1950, la firma BOEING emprendió el estudio de un cuatrimotor de vocación civil y militar. El prototipo hizo su primer vuelo el 15 de julio de 1954 y, en septiembre, la US AIR FORCE hizo un importante pedido de aviones nodrizas: el KC 135. El 15 de octubre, la PAN AMERICAN hizo un pedido de seis Boeing 707-121.

Más tarde, el Boeing 707 se desarrolló paralelamente a las versiones C.135 militares para dar como resultado la serie 200 fundamentalmente diferentes.

**CARACTERÍSTICAS**

Longitud : 46,61 m  
 Envergadura : 44,42 m  
 Altura : 12,94 m  
 Reactores : 4 Pratt & Whitney JT3D

**NL**

Het is in 1950 dat de BOEING Firma de studie van een vierreaktor met burgeren militaire roeping aanving. Op 15 juli 1954 voerde het prototype de eerste vlucht uit en in september sloot de U.S. Air Force een belangrijk order van proviandvliegtuigen, de KC 135. Op 15 oktober, bestelde de PAN AMERICAN zes Boeing 707-121. Later werd de Boeing 707 parallel met de C. 135 militaire versies ontwikkelt, om geheel en al verschillende series 200 te geven.

**EIGENSCHAPPEN**

Lengte : 46,61 m  
 Spanwijdte : 44,42 m.  
 Hoogte : 12,94 m  
 Reactors : 4 Pratt & Whitney JT3D

**I**

Nel 1950, la società BOEING ha dato il via al progetto per un quadriereattore a vocazione civile e militare. Il prototipo ha ricevuto il battesimo dell'aria il 15 Luglio 1954. Nel settembre dello stesso anno, l'U.S.A. AIR FORCE firmava un importante ordine per aerei di rifornimento : il modello KC 135. Il 15 Ottobre, la PAN AMERICAN ordinava a sua volta sei Boeing 707-121. Successivamente, il Boeing 707 è stato sviluppato in parallelo, contemporaneamente alle versioni C. 135 militare, per creare le serie 200, fundamentalmente differenti .

**CARATTERISTICHE**

Lunghezza : 44,61 m  
 Apertura alare : 44,42 m  
 Altezza : 12,94 m  
 Reattori : 4 Pratt & Whitney JT3D

**S**

Det var år 1950 som firman BOEING började planera ett fyrmotorigt flygplan för både civil och militär användning. Prototypen flög för första gången den 15 juli 1954 och i september gjorde US AIR FORCE en stor beställning av tankplan, KC 135. Den 15 oktober beställde PAN AMERICAN sex stycken Boeing 707-121. Senare framställdes Boeing 707 parallellt med den militära versionen C. 135 och gav uppnov till de helt olika serierna 200 .

**SPECIFIKATIONER**

Längd : 46,61 m  
 Vingbredd : 44,42 m  
 Höjd : 12,94 m  
 Jetmotorer : 4 Pratt & Whitney JT3D

**FIN**

Vuonna 1950 BOEING-yhtiö alkoi suunnitella nelimoottorisen sekä siviili-että sotilasilmailun käyttöön tarkoitetun lentokoneen rakentamista. Prototyyppi lensi ensimmäistä kertaa 15 heinäkuuta 1954 ja syyskuussa USAIRFORCE tilasi huomattavan määrän tankkikoneita (KC 135). 15 lokakuuta PAN AMERICAN tilasi kuusi Boeing 707-121. Myöhemmin Boeing 707 kehitettiin samanaikaisesti C 135 sotilaskoneen kanssa, jolloin 200-sarjat muuttuivat kokonaan.

**TIEDOT**

Pituus : 46,61 m  
 Siipien väli : 44,42 m  
 Korkeus : 12,94 m  
 Suihkumoottorit : 4 Pratt & Whitney JT3D

PEINTURES ESSENTIELLES / ESSENTIAL PAINTS



11  
Argent  
Silver  
Silber



15  
Bleu nuit brillant  
Gloss midnight blue  
Glänzend -Mitternachtblau



22  
Blanc brillant  
Gloss white  
Glänzend-Weiss



33  
Noir mat  
Matt black  
Matt-Schwarz



40  
Gris pale brillant  
Gloss pale grey  
Glänzend-Blassgrau



41  
Ivoire brillant  
Gloss ivory  
Glänzend-Elfenbein



56  
Aluminium  
Aluminium  
Aluminium



91  
Vert noir mat  
Matt black green  
Matt-Schwarzgrün



96  
Bleu RAF mat  
Matt RAF blue  
Matt-Luftwaffenblau



103  
Crème mat  
Matt cream  
Matt-Creme

- Si aucune teinte n'est spécifiée, peindre dans les couleurs de la version choisie. Se reporter aux pages 10 & 11 pour le détail du schéma de peinture.
- When no color is specified, paint the item with colors of chosen version. Refer to pages 10 & 11 for painting pattern.
- Wenn keine Farbe angegeben ist, Teile mit den Farben der gewählten Version bemalen. Beachten Sie die Seiten 10 & 11 für die Lackierung und Markierung.
- Cuando ningún color es especificado, pintarle con los colores del tema de la versión elegida. Vea las páginas 10 & 11 para obtener detalles de pintura.

a • BOEING 707-328B AIR FRANCE



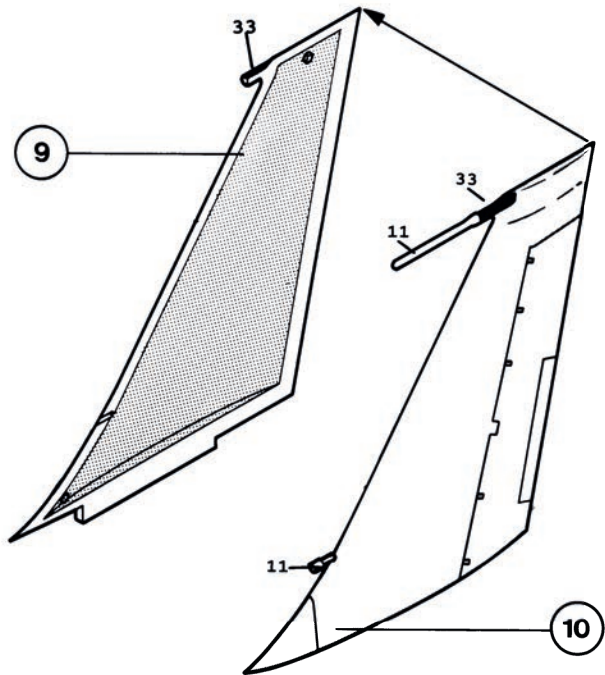
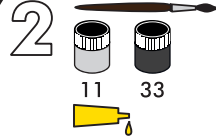
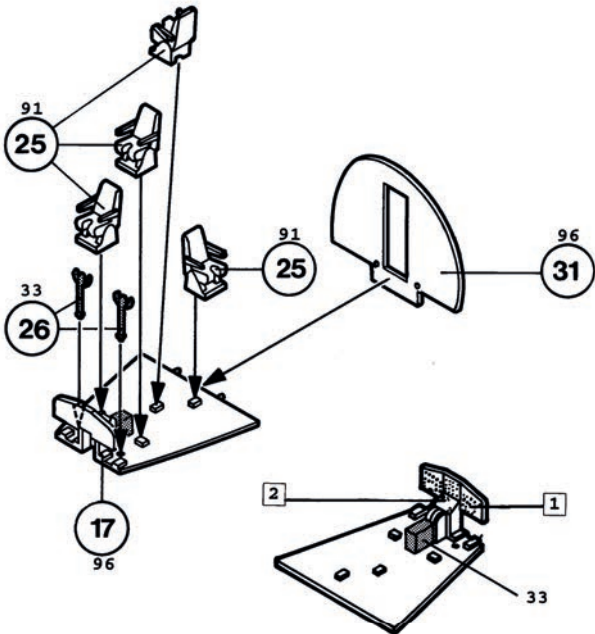
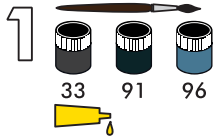

b • BOEING 707-320 BOAC





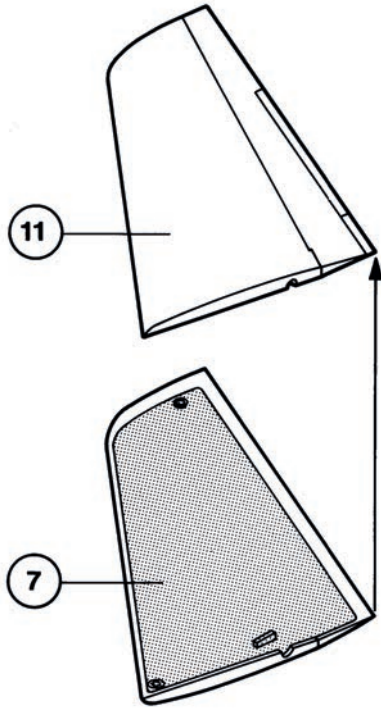



3 

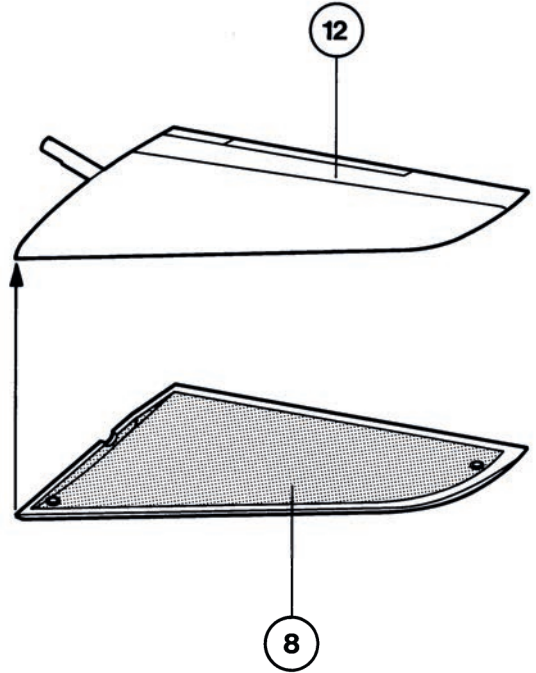





4 

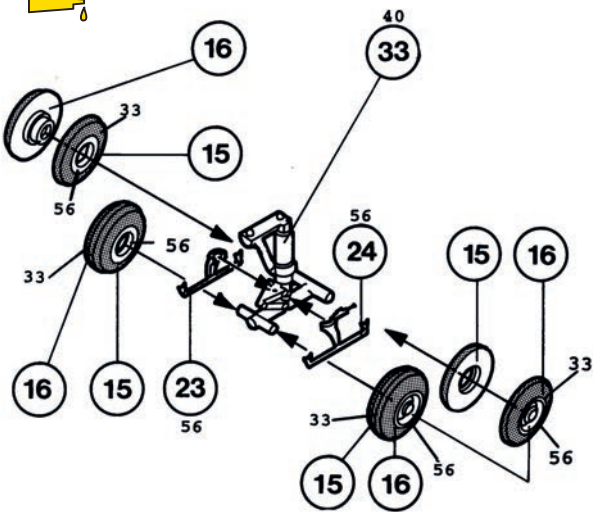





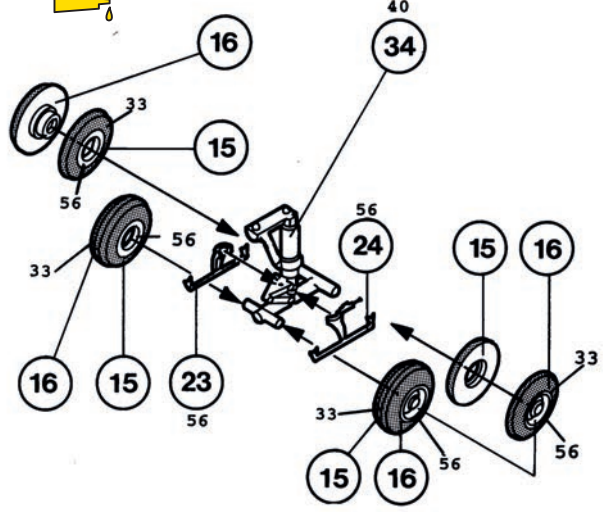

5   
  
  



6   
  
  



7   
  
  
  
  

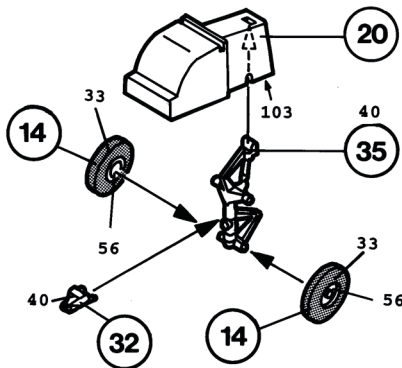

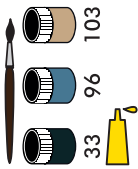
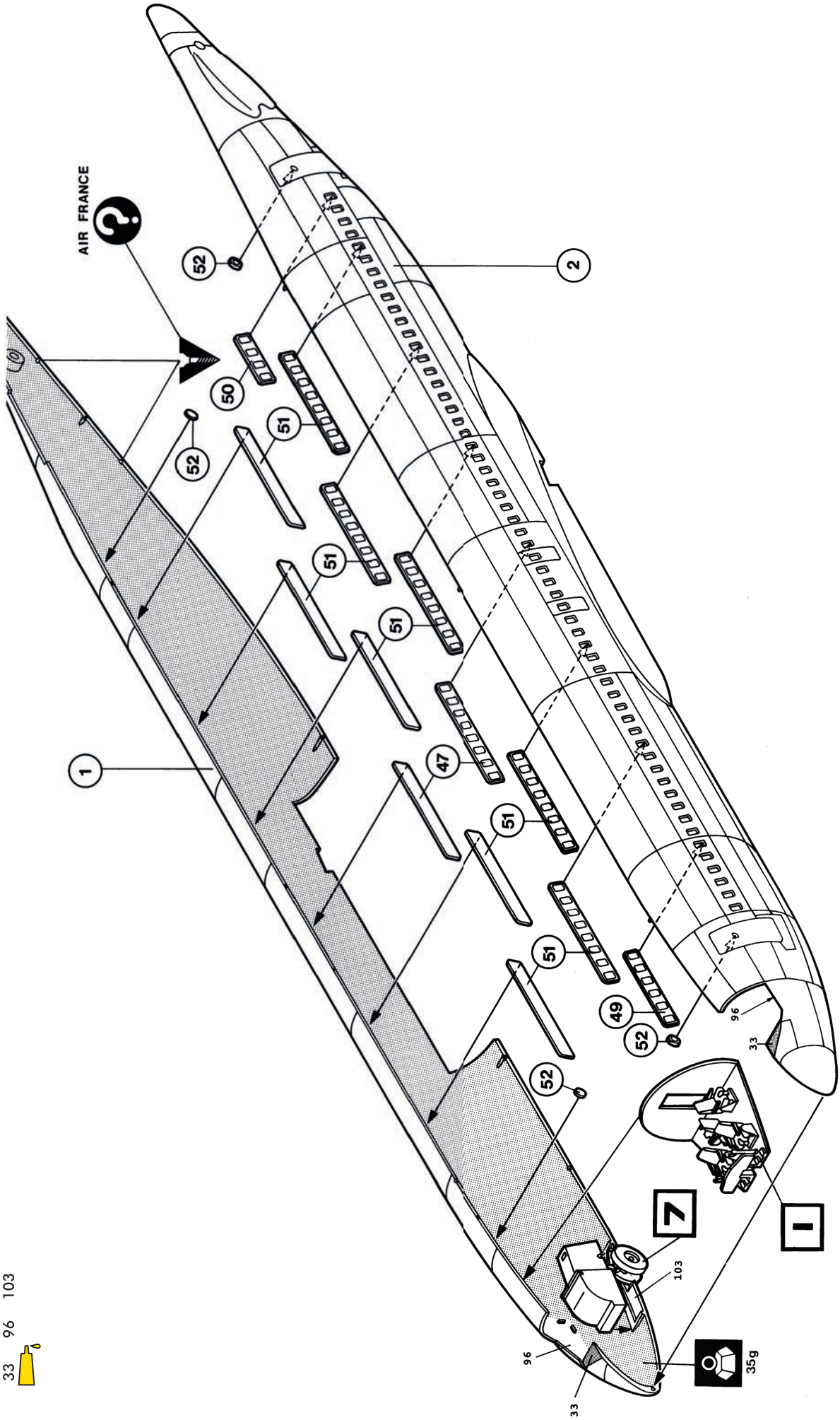

8

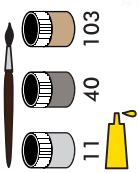

9

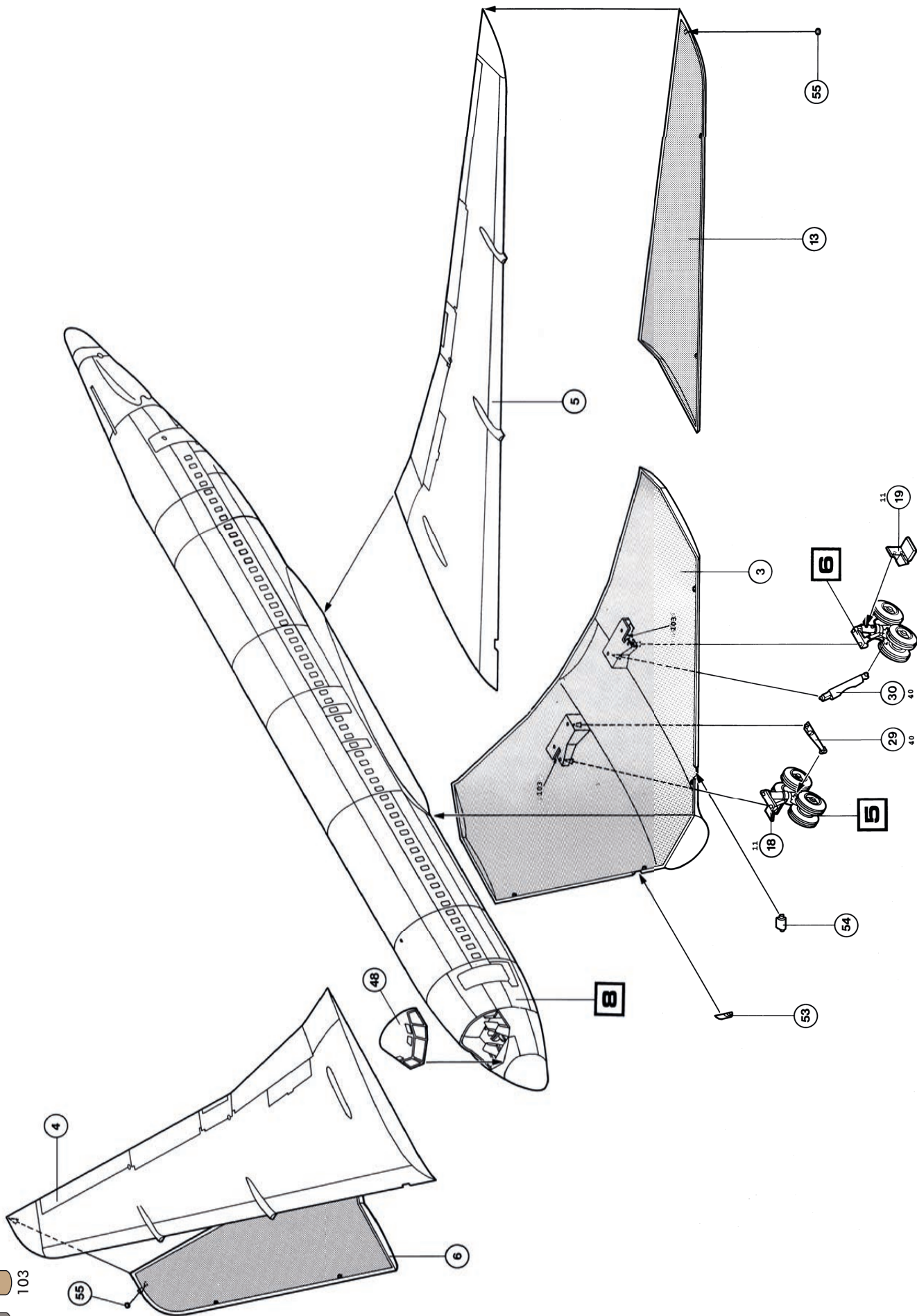



10

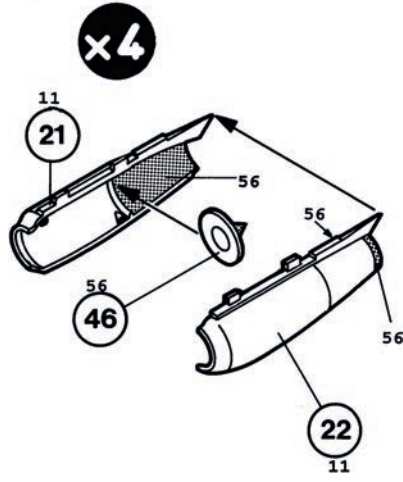
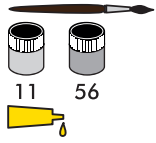

11

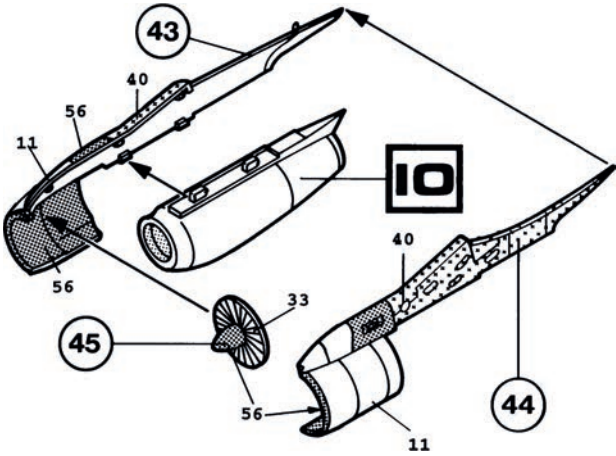
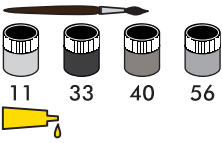

12

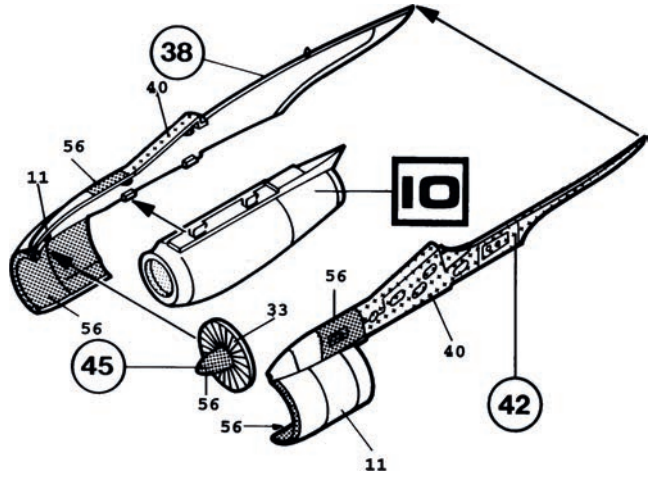
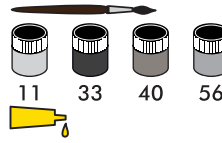

13

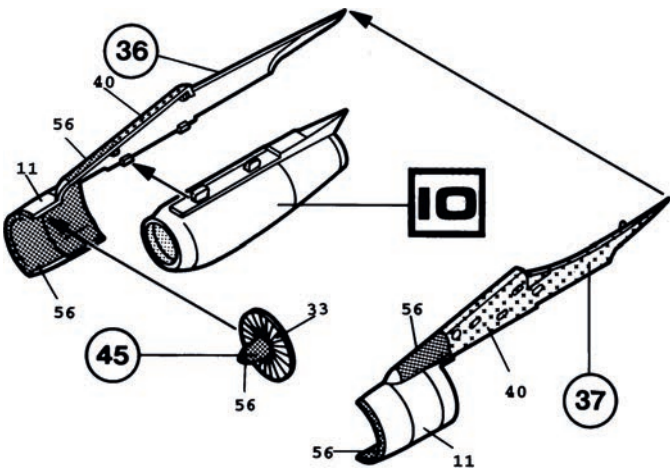
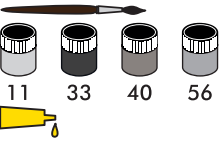

14

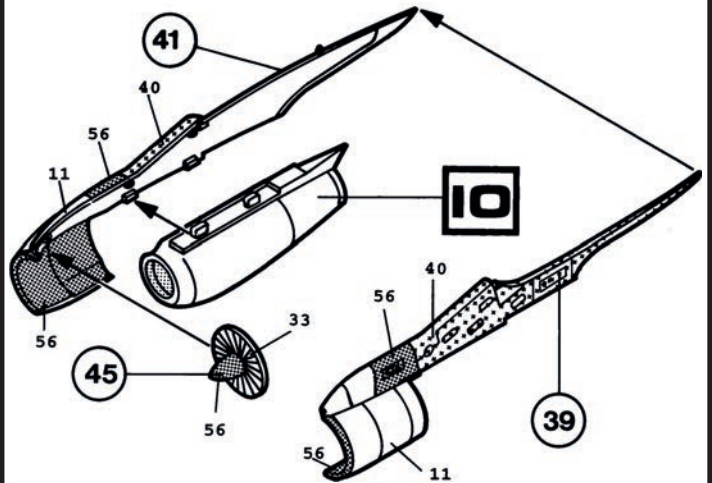
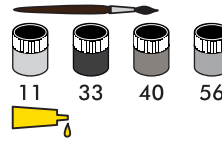





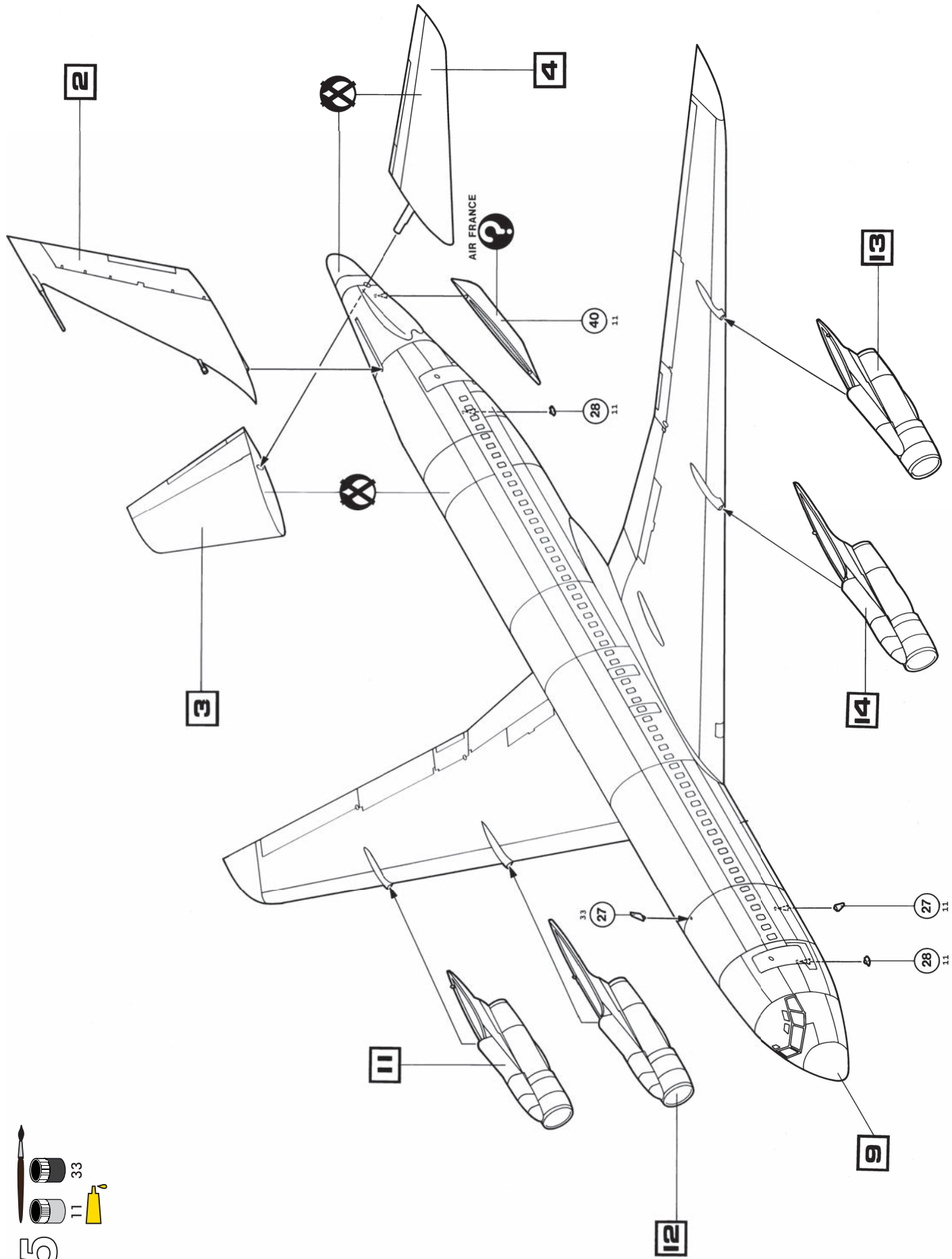
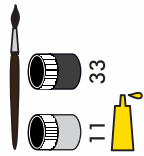



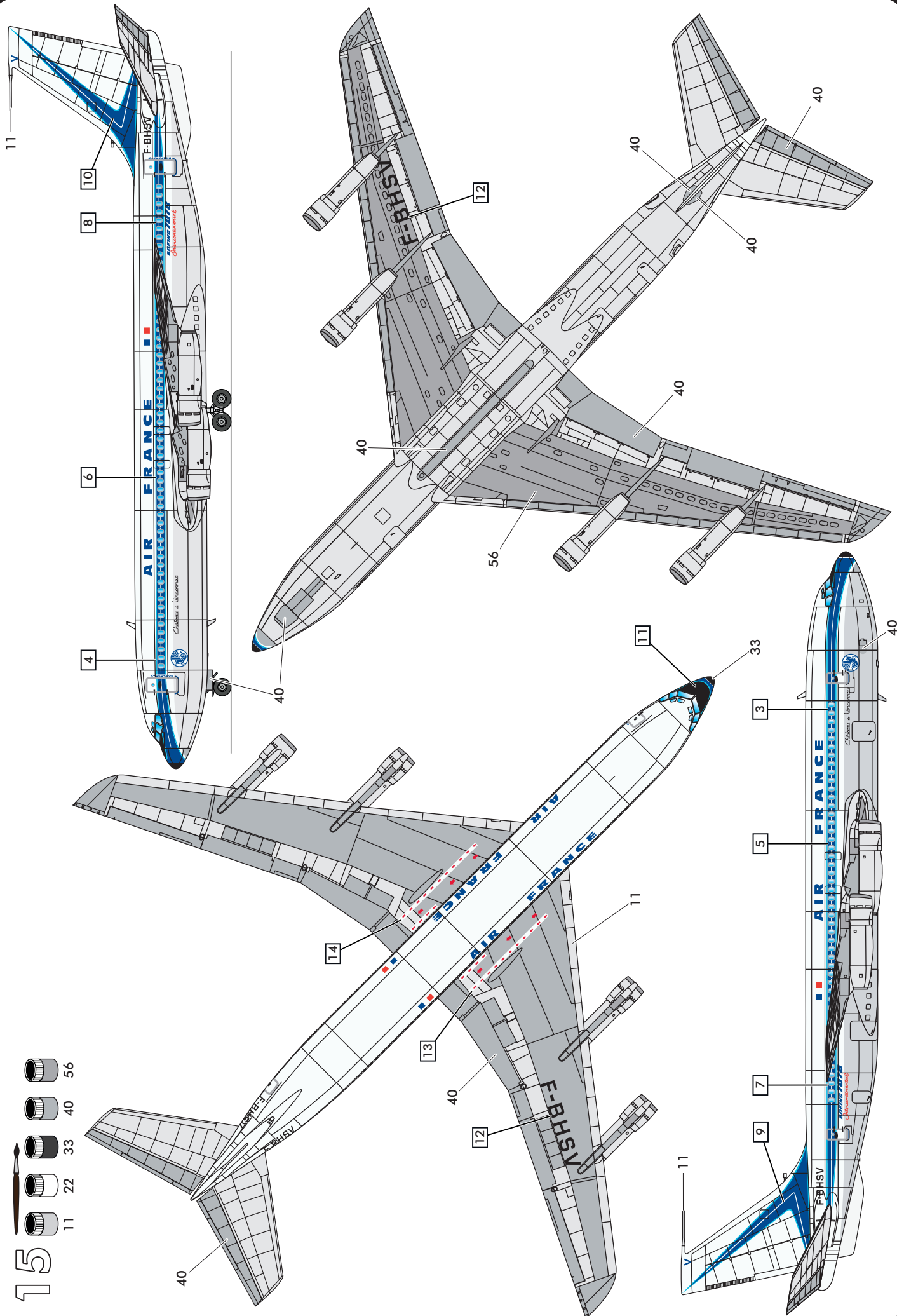
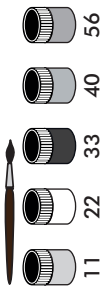

# 15



15



16

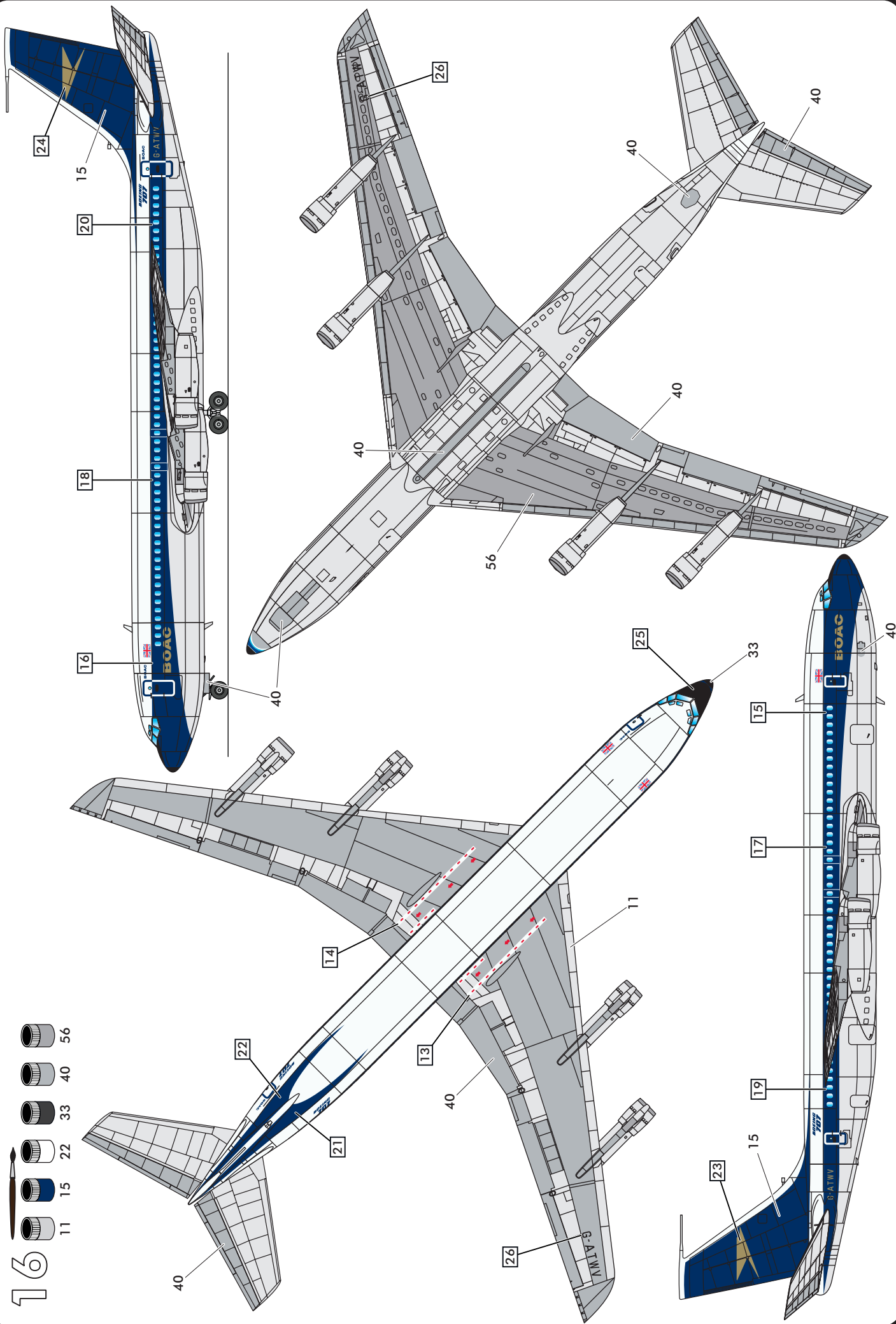

-  56
-  40
-  33
-  22
-  15
-  11
- 





# VISITEZ-NOUS EN LIGNE!

VISIT US DIGITALLY!  
BESUCHEN SIE UNS DIGITAL!

 [www.heller.fr](http://www.heller.fr)  
 [instagram.com/heller.fr](https://www.instagram.com/heller.fr)  
 [facebook.com/heller.fr](https://www.facebook.com/heller.fr)

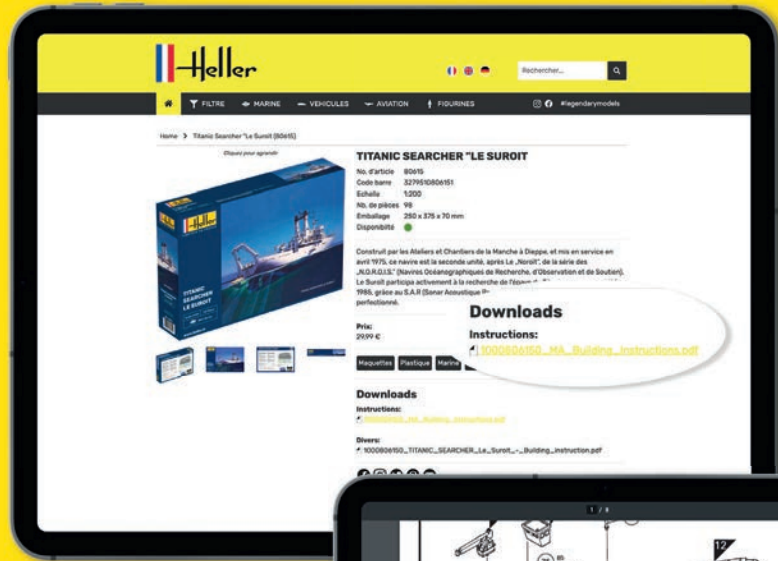

Choisissez l'article que vous désirez et téléchargez les instructions.  
Choose your desired article and download the instruction.  
Wählen Sie den gewünschten Artikel und laden Sie die Anleitung herunter.

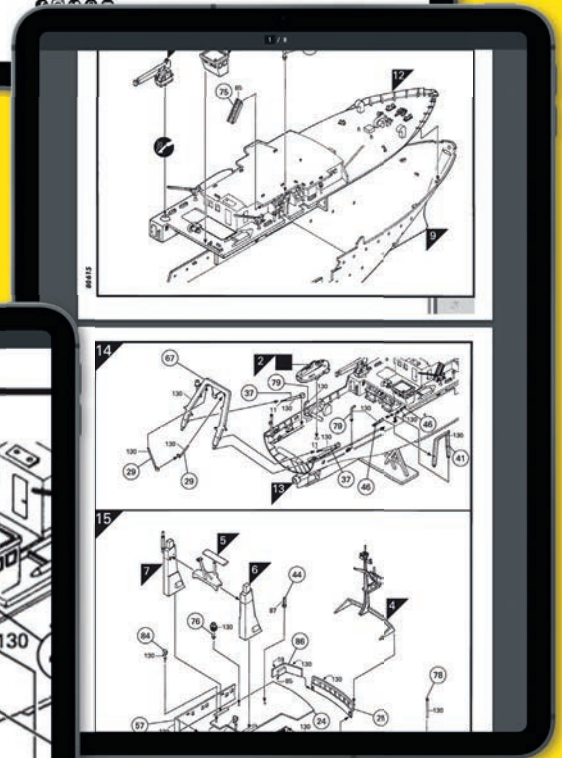

**Download all instructions!**

Grossissement des instructions pour une détaillée.

Enlarge the instruction for a more detailed view.

Vergrößern Sie die Anleitung für eine detailliertere Ansicht.

V-041120

**Service Consommateurs**  
Pour toute demande de SAV, connectez-vous sur notre site [www.heller.fr](http://www.heller.fr).

**Customer Service**  
For after-sales service requests, please contact us through our website [www.heller.fr](http://www.heller.fr).

**Endverbraucherservice**  
Bitte besuchen Sie uns auf [www.heller.fr](http://www.heller.fr) für alle Ersatzteilanforderungen.

**Heller Hobby GmbH**  
Erlenbacher Str. 3 • 42477 - Radevormwald • GERMANY  
 +49 2195-92773-0  [info@heller.fr](mailto:info@heller.fr)