

Plastic model kit containing 554 parts.

Wing span: 587.7mm Length: 457 mm

1/32  
SCALE



# A-20G Havoc over Europe

## History of A-20G Havoc

**T**he Douglas A-20 Havoc is an American-designed, twin-engine, medium bomber used mainly for low- and medium altitude missions. The prototype made its maiden flight on August, 7<sup>th</sup> 1939, and the type was first used operationally by the French. After their defeat at the end of June 1940, the remainder of the aircraft still to be delivered were taken over by the RAF as the Boston (Havoc for night-fighter versions).

With a production of 7.478 aircraft built, it was widely used by the Allies such as the USAAF, RAF, RAAF, SAAF, Soviet Air Force, France and postwar by Brasil and Nicaragua.

With a crew of three it was initially used for bombing operations when fitted with glazed noses, later types were fitted with a Martin 250CE dorsal turret and a six-gun solid nose, which made them suitable for strafing missions. Apart from the Europe theatre of operations, the A-20 was widely used operationally in North Africa, the Pacific, New-Guinea and the Eastern Front.

- |   |  |  |
|---|--|--|
|  BE CAREFUL                              |  REMOVE                 |  GLUE TOGETHER  |
|  PLEASE WAIT FOR A FEW MINUTES UNTIL DRY |  MAKE 2 PIECES          |  DRILL HOLE     |
|  DO NOT GLUE                             |  INSTANT GLUE FOR METAL |  BEND           |
|  FILL HOLE                               |  SEQUENCE OF WORK       |  OPTIONAL       |
|  USED COLOUR                             |  APPLY DECAL            |  MARKING OPTION |

### CAUTION

When using both glue and paint, do not use these near an open flame, due to the flammable properties of these items.

The symbols provided, such as 'X', refer to the basic colours of parts, although a more comprehensive list is supplied for your use for Tamiya, Mr Hobby and AK-Interactive codes.

When removing parts from sprues, take extreme care. Consider correct tools such as Xuron Sprue Cutters

Please check the symbology on the left and familiarise yourself before building this model kit.

In cooperation with:



www.ak-interactive.com



1

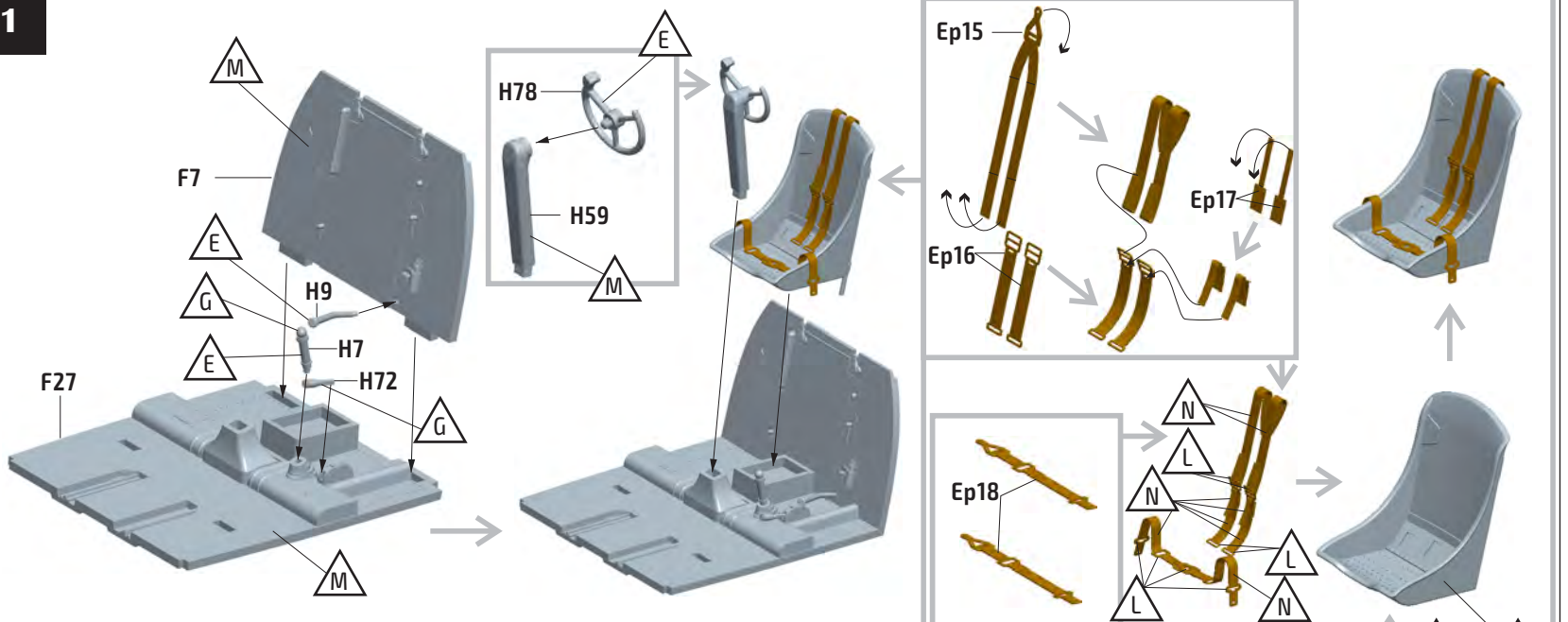

2

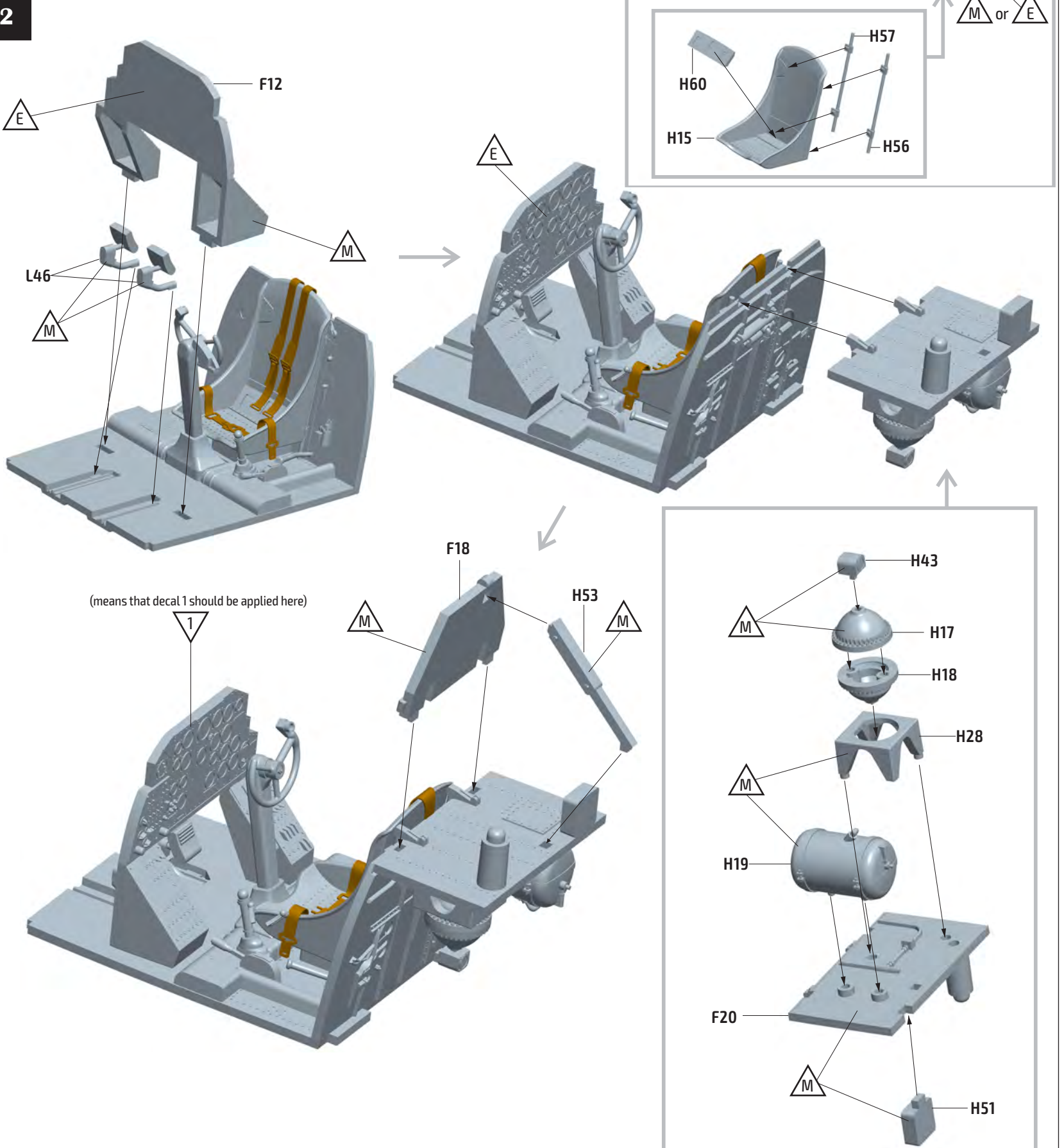



3

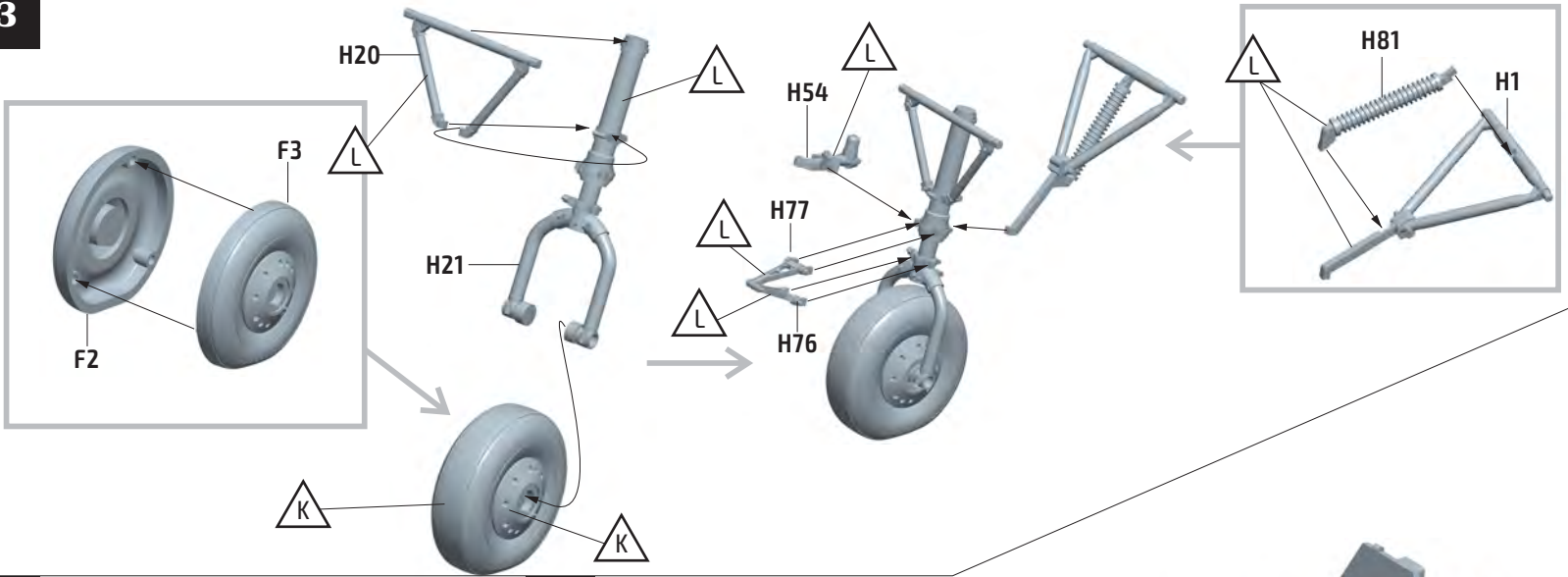

4

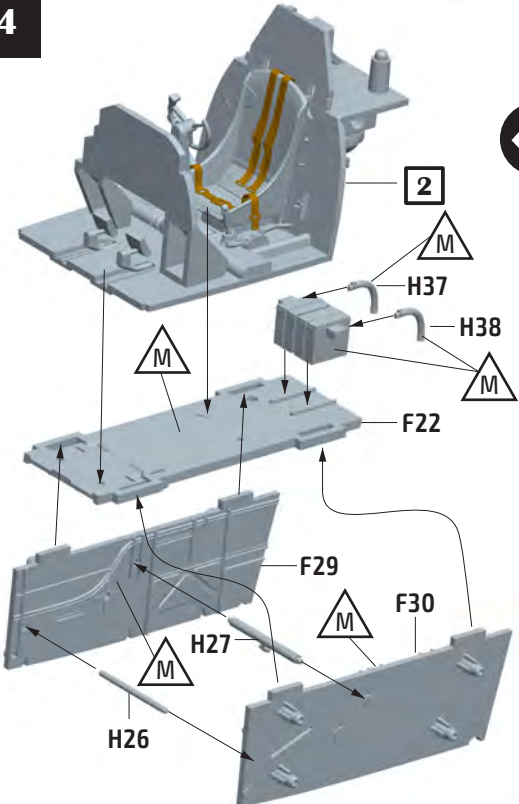

4-1

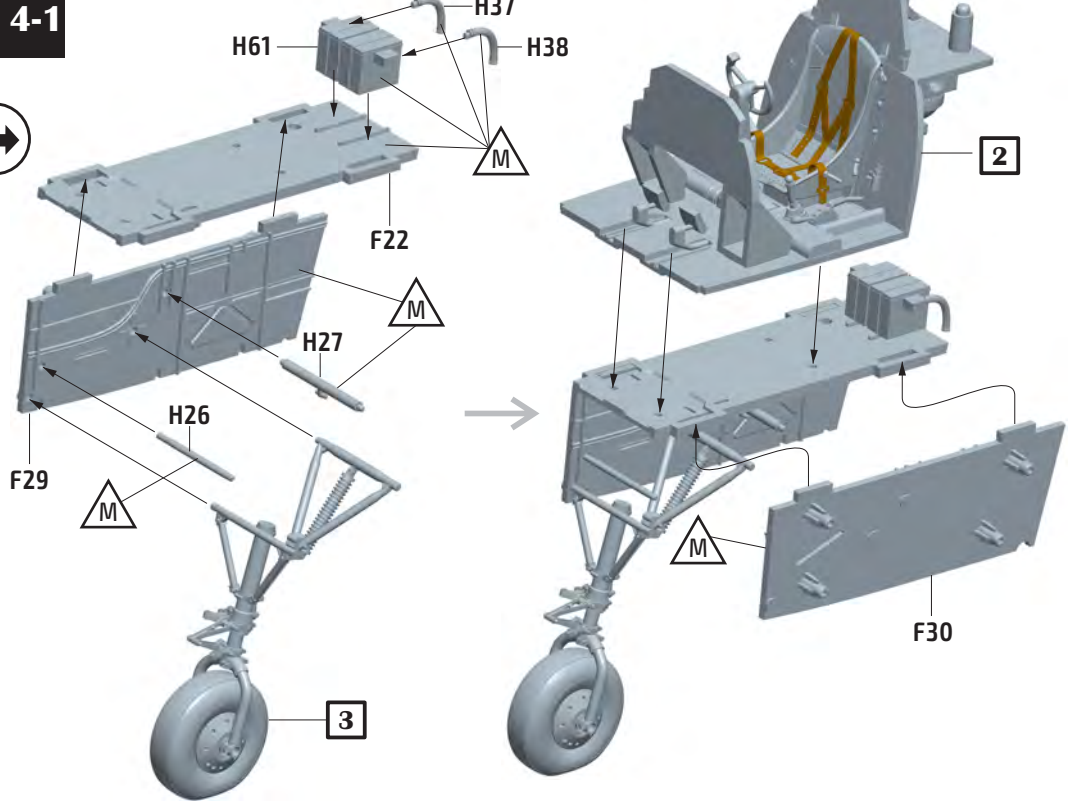

5

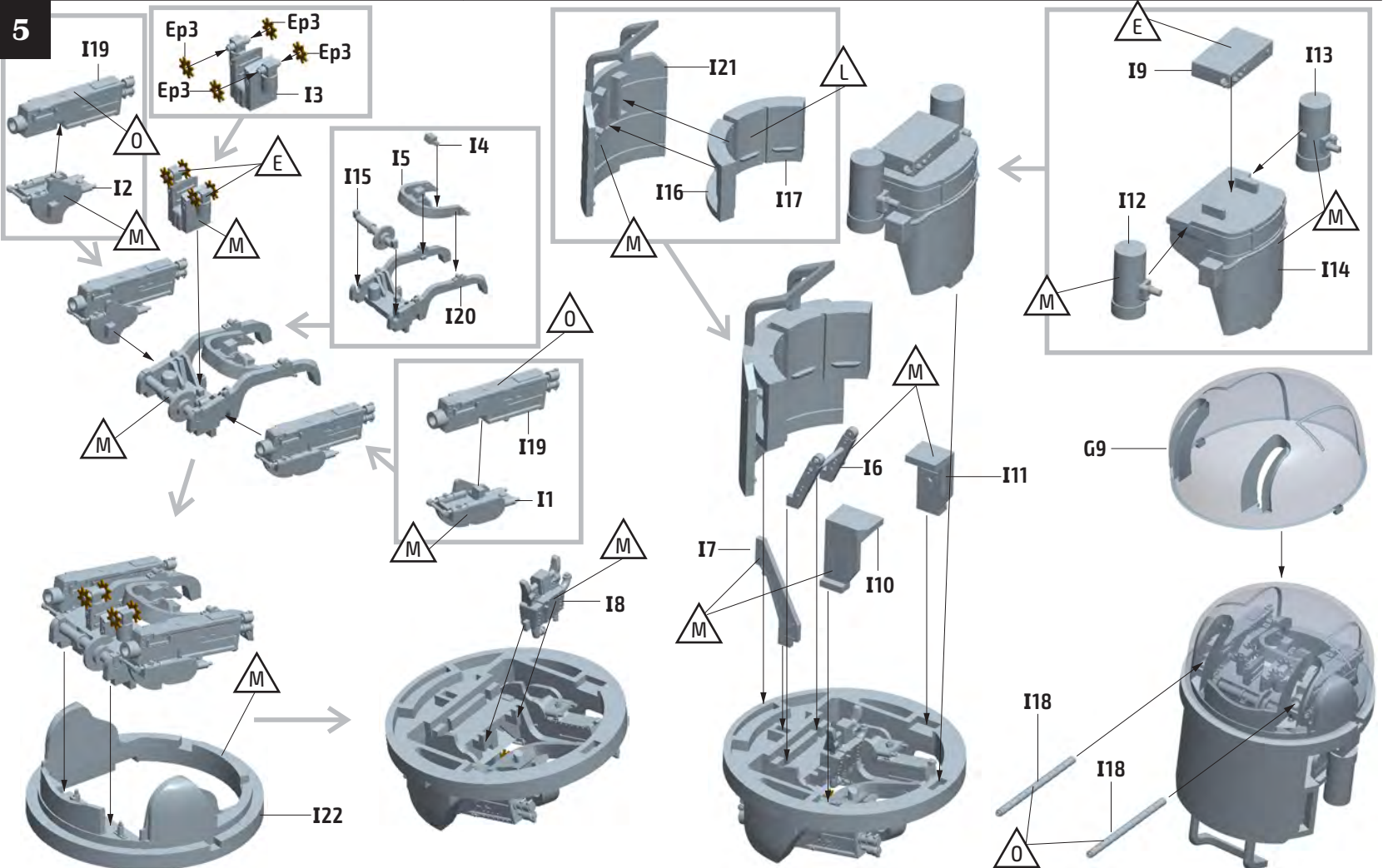



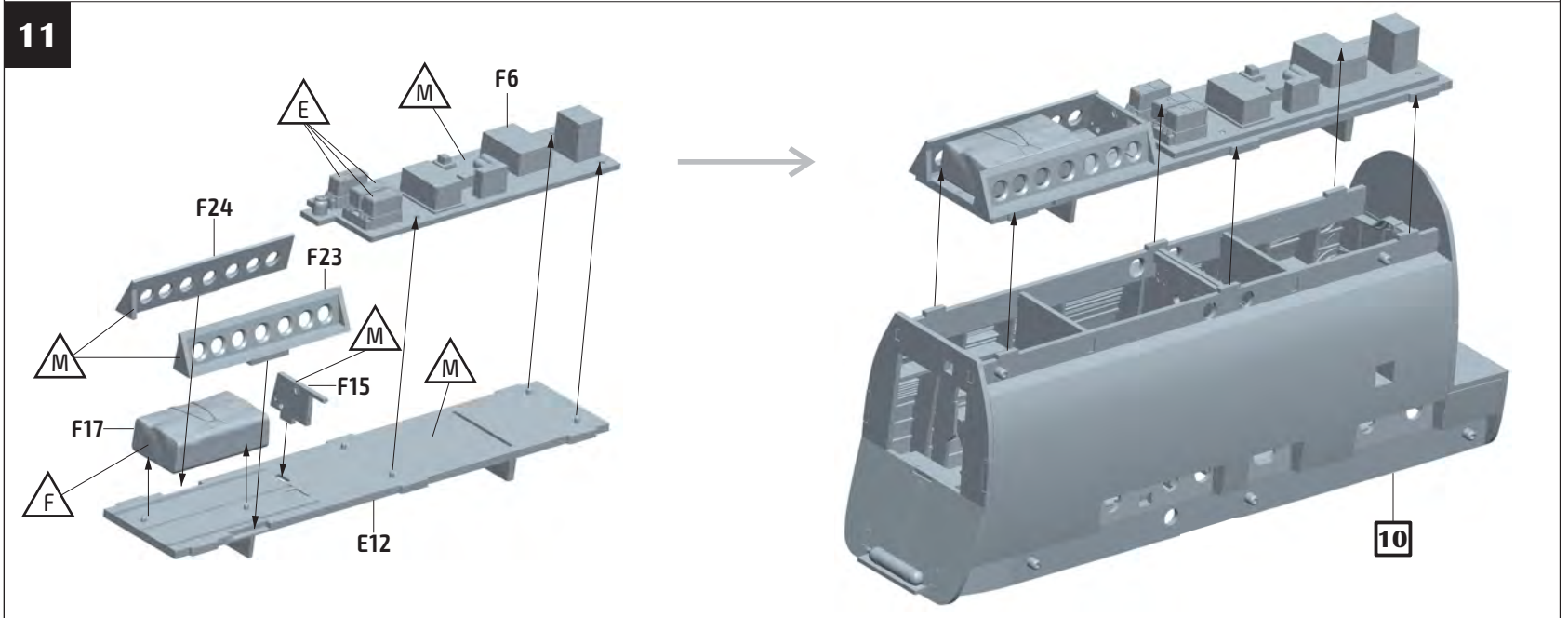
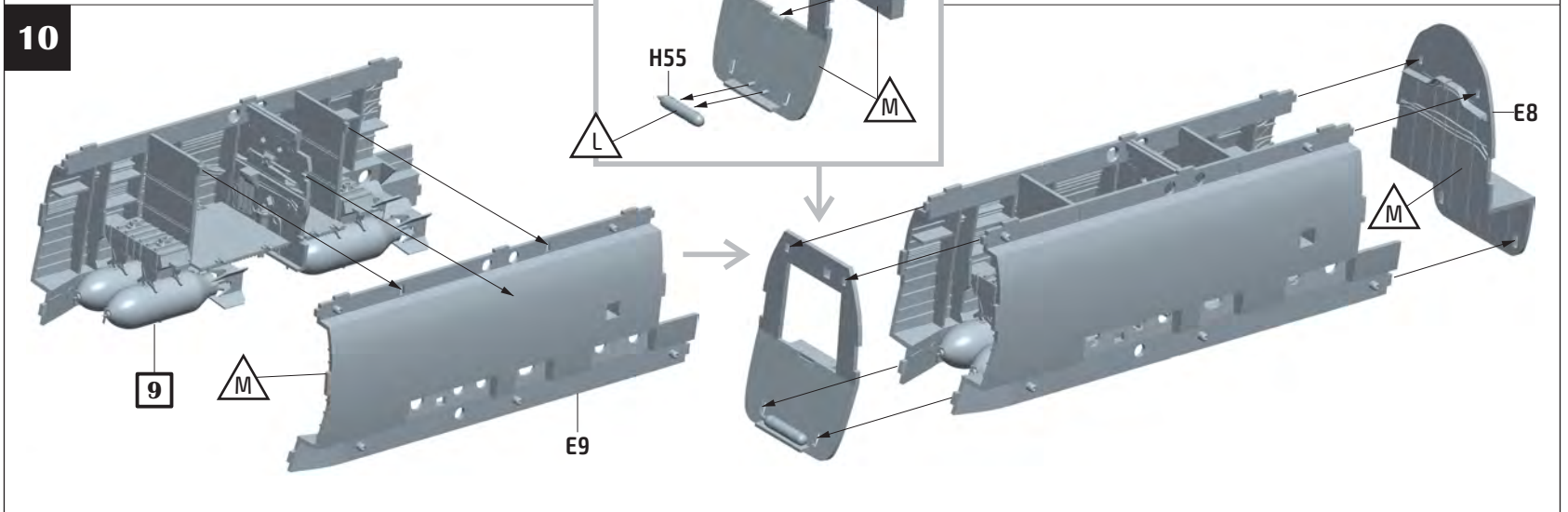
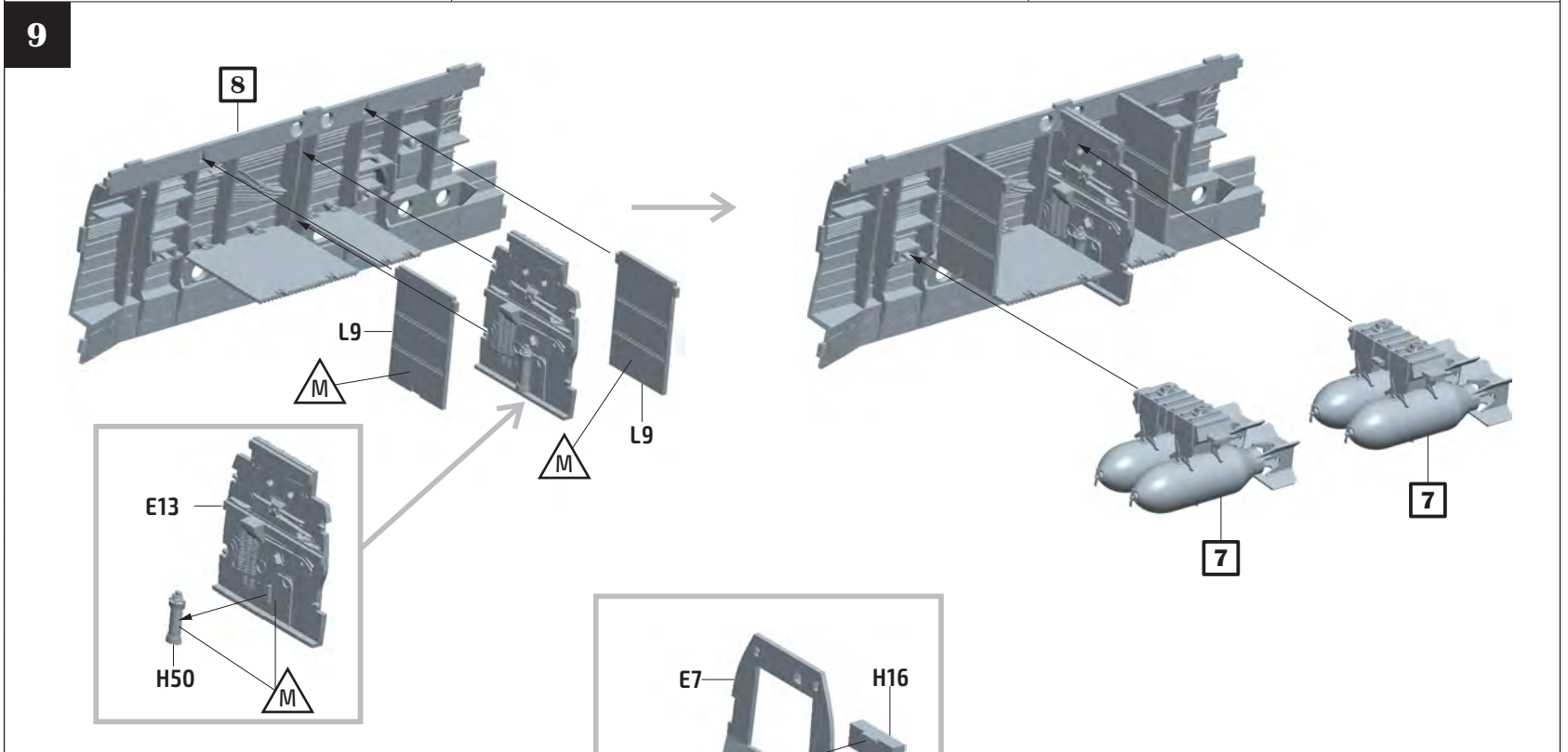
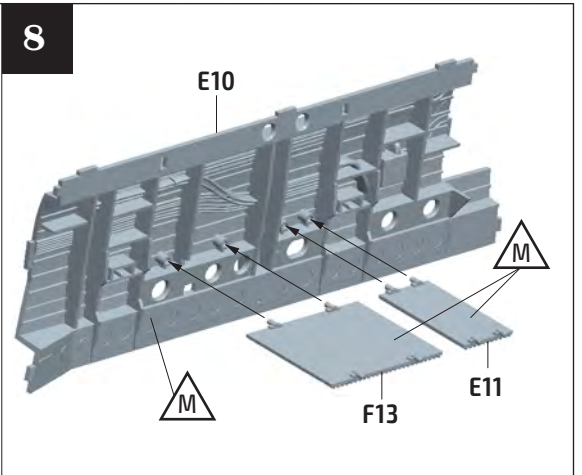
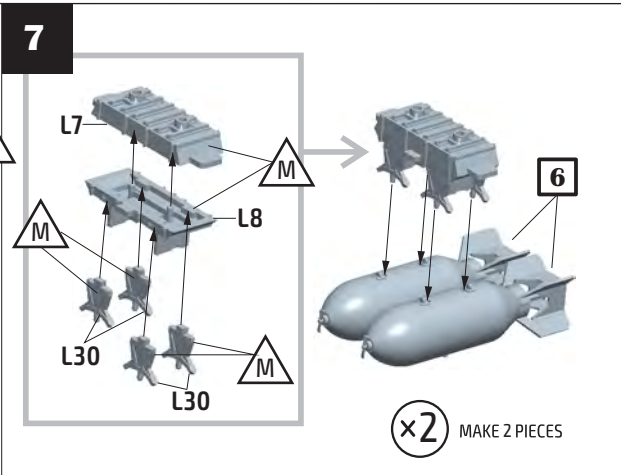
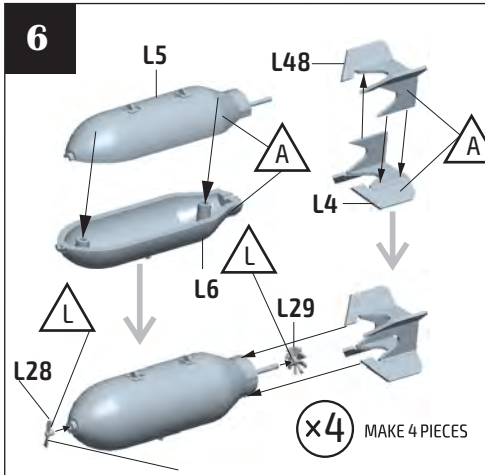

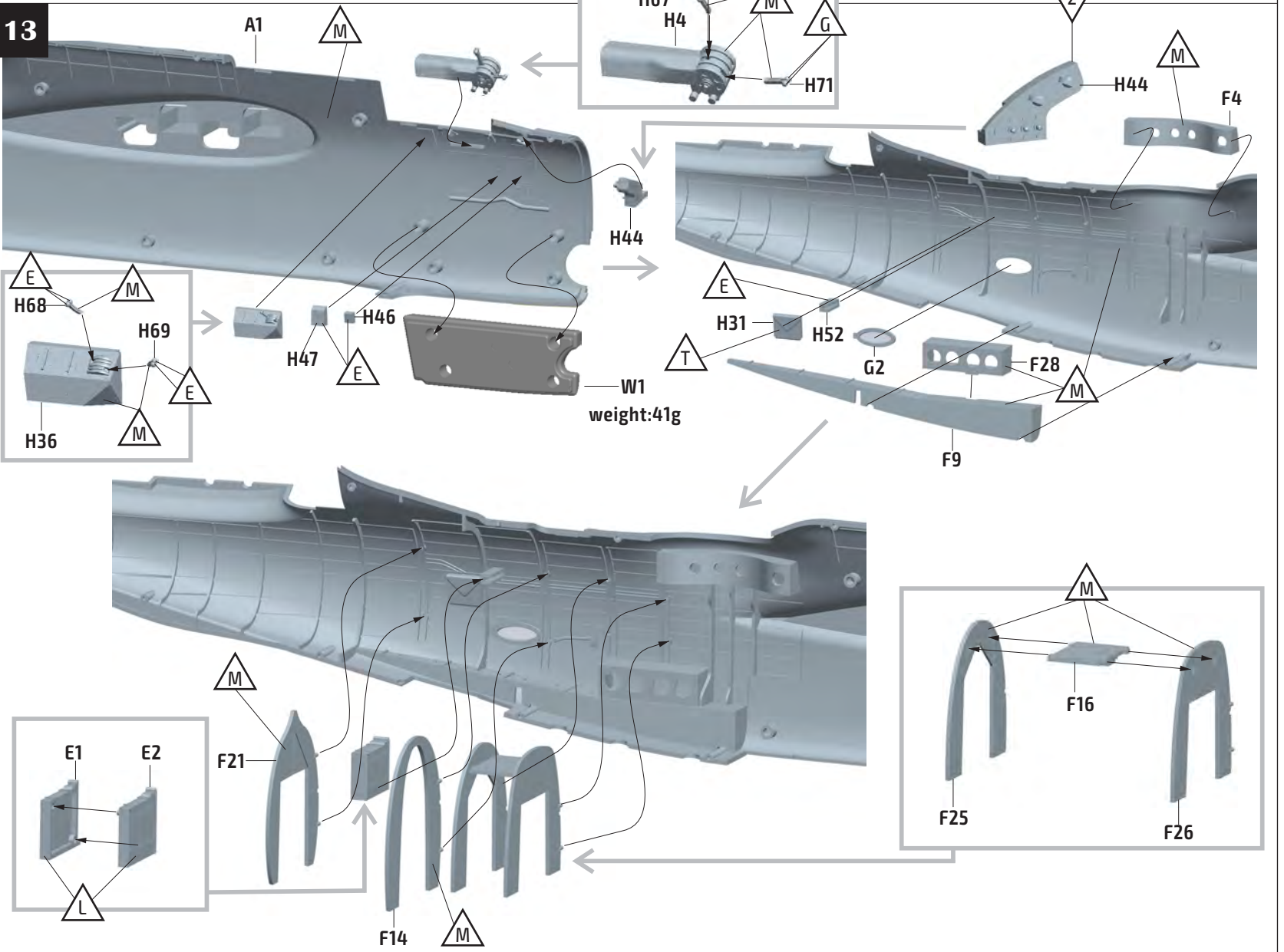
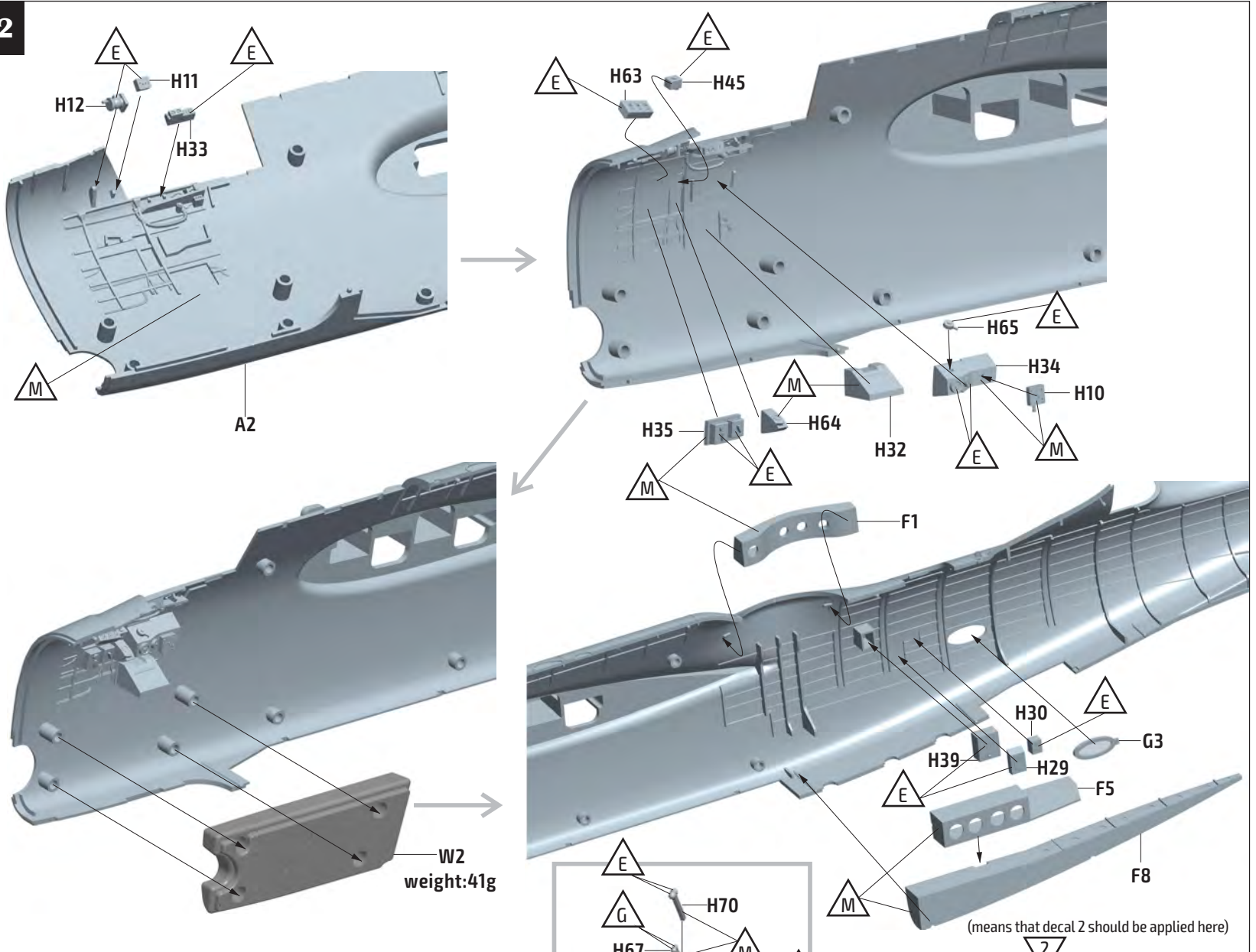



14

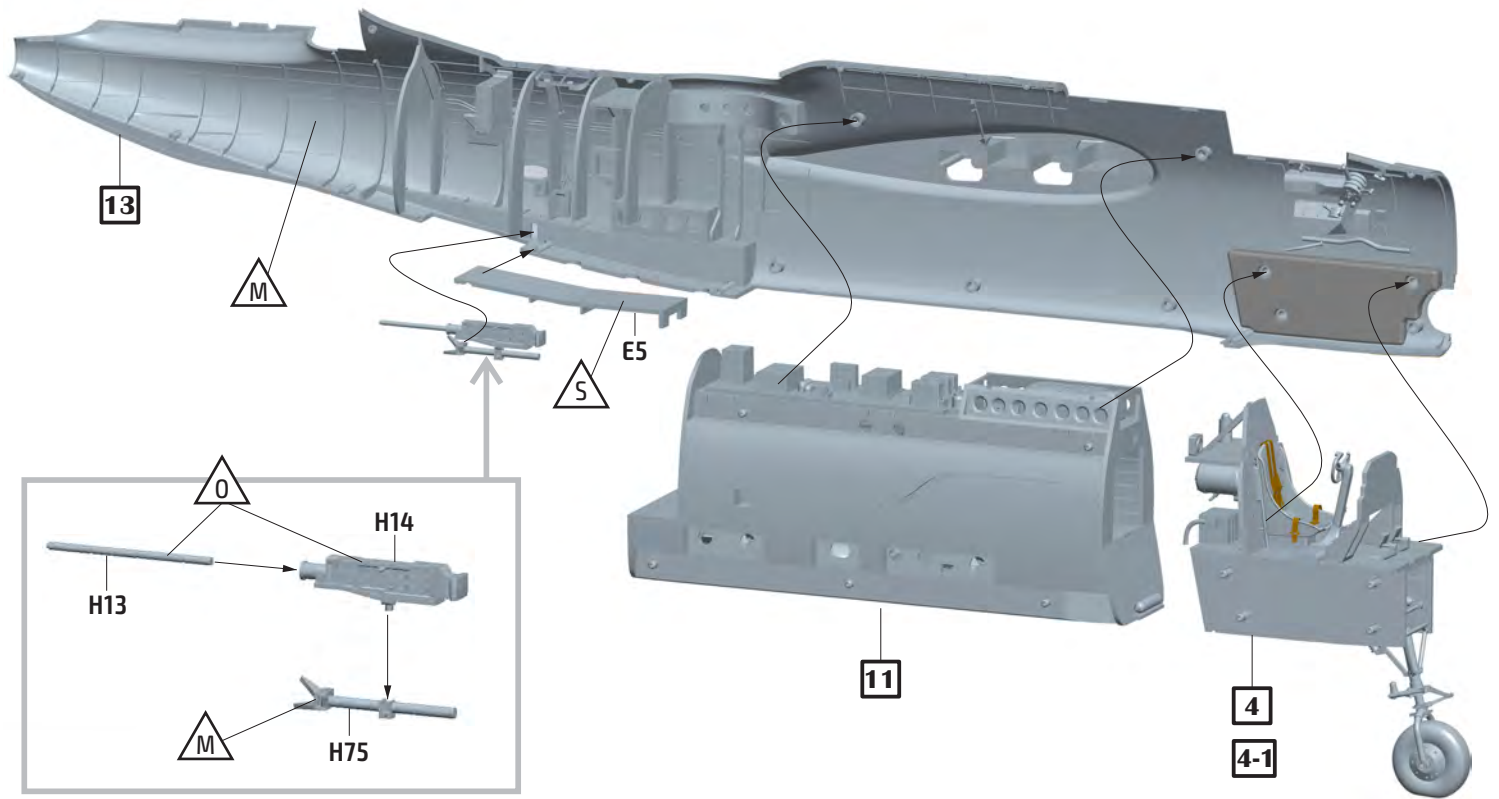

15

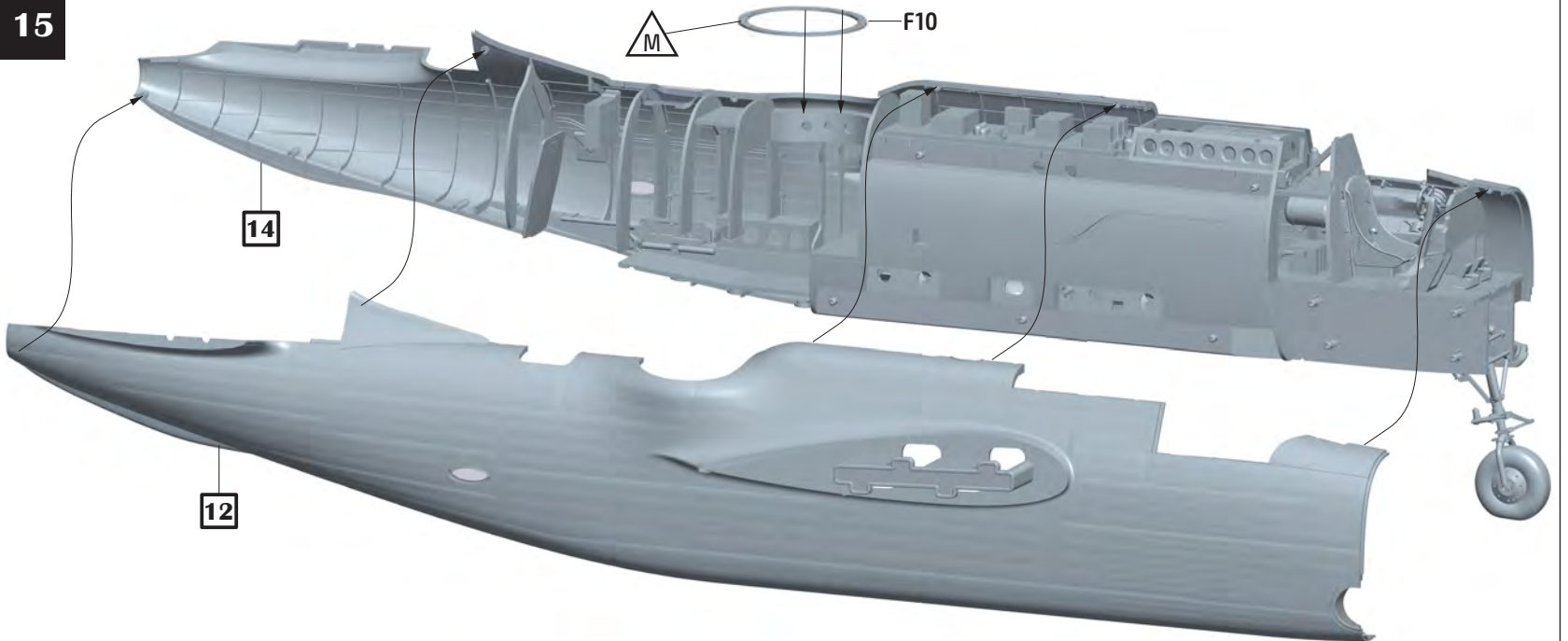

16

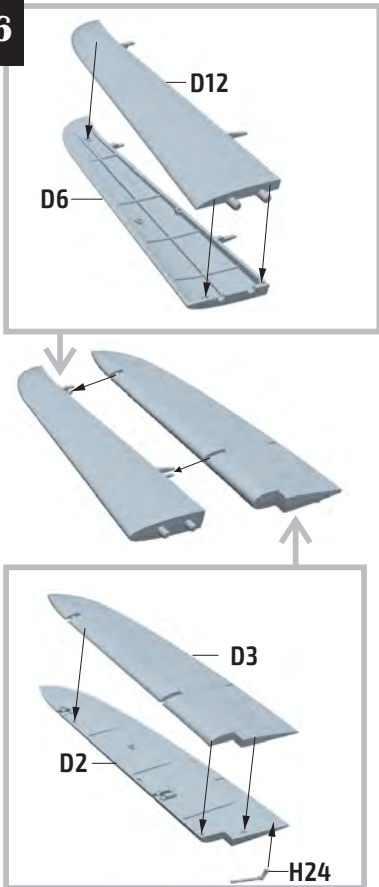

17

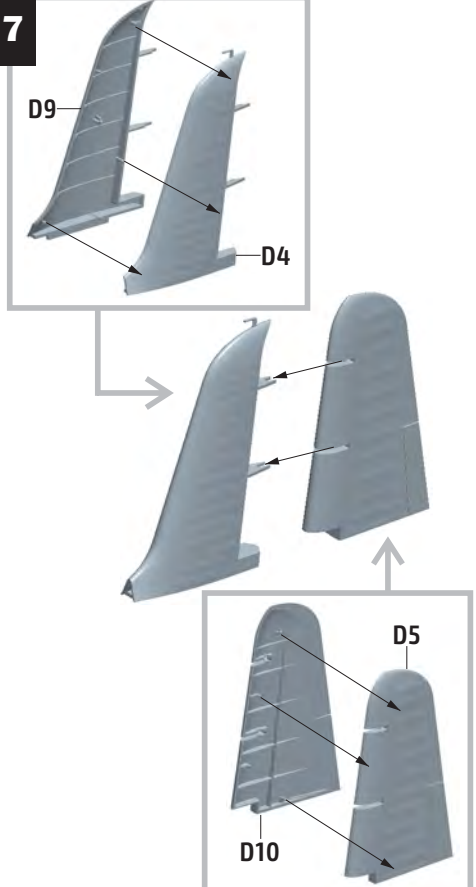

18

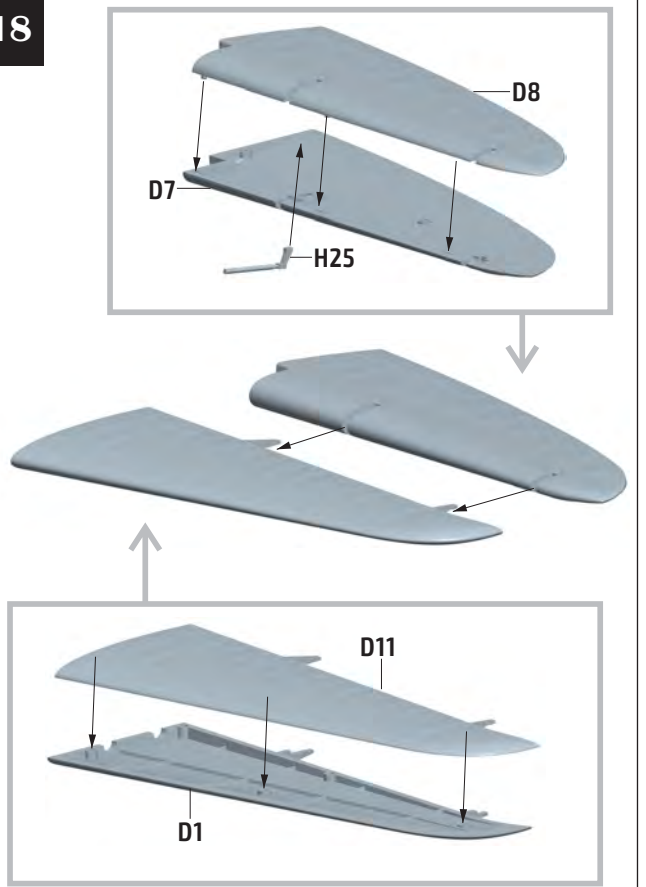

19

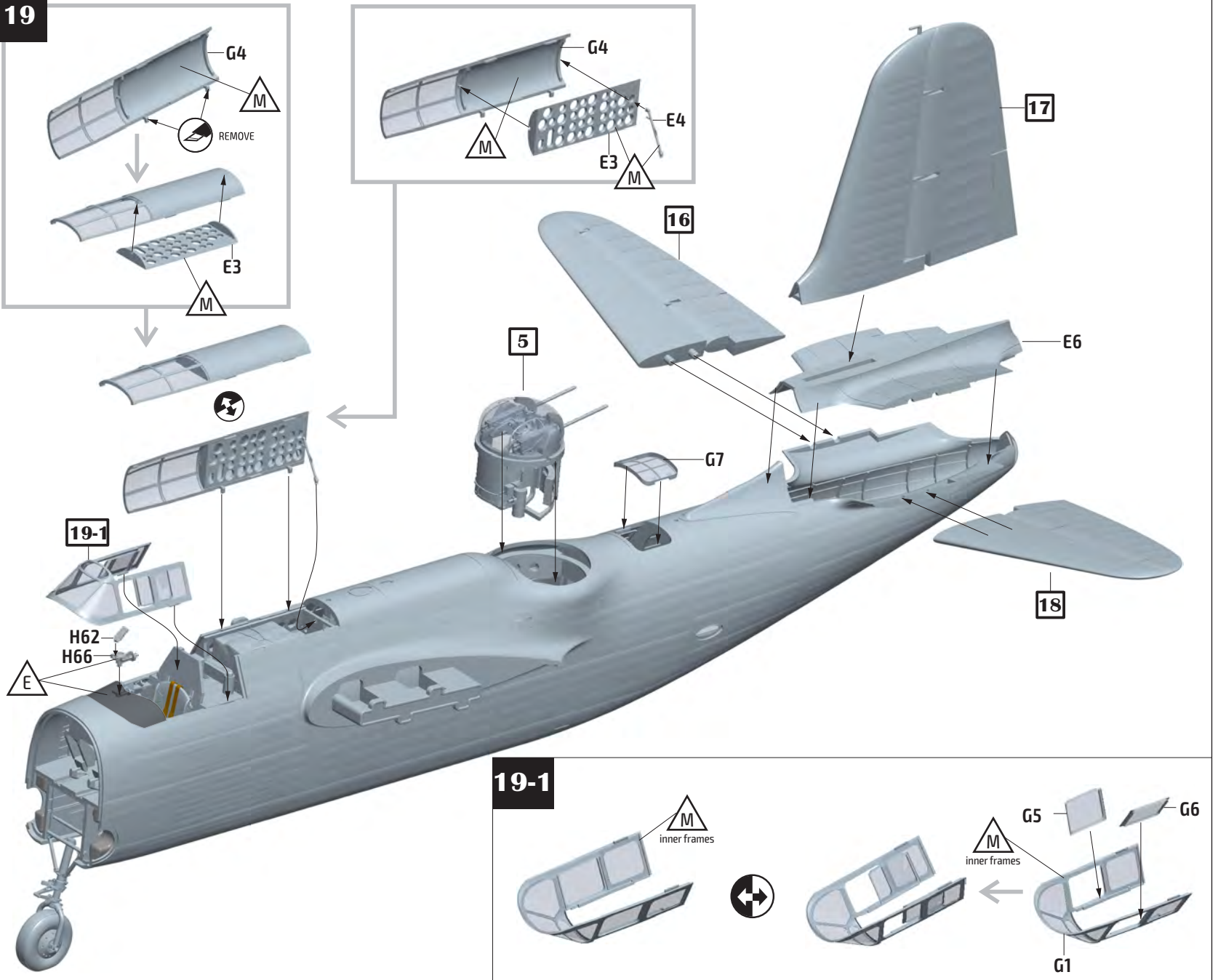

19-1

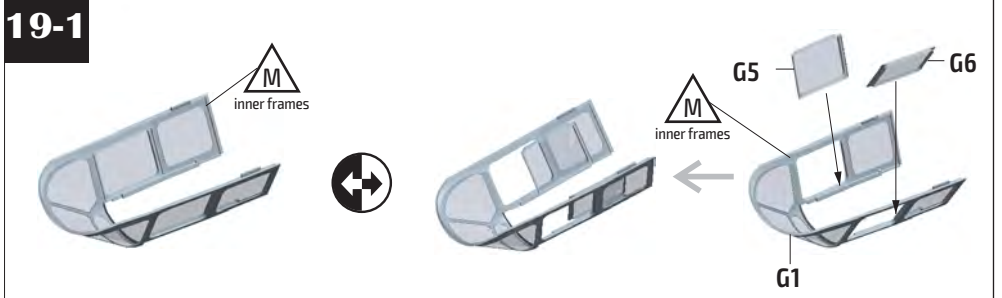

20

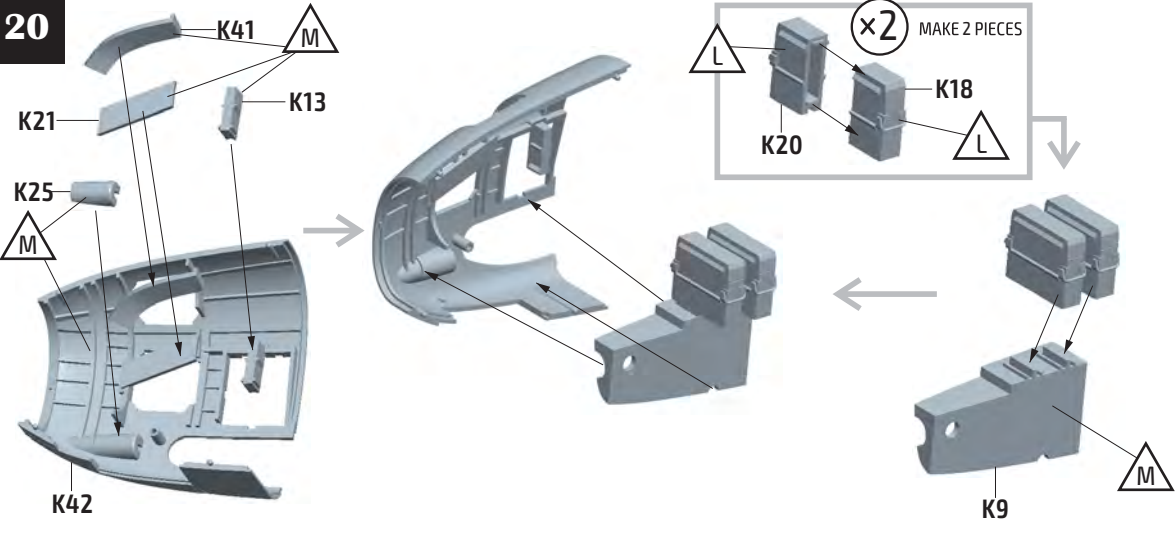

21

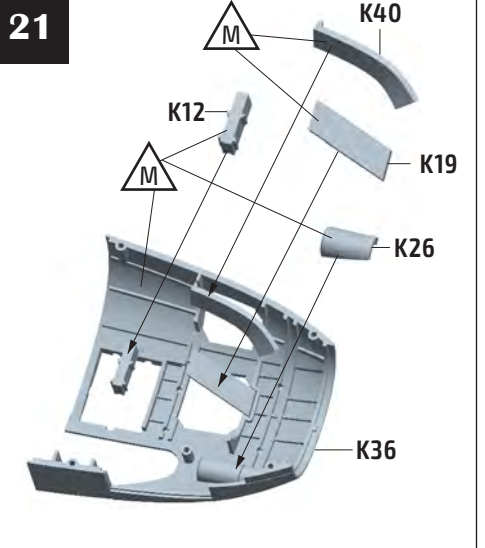

22

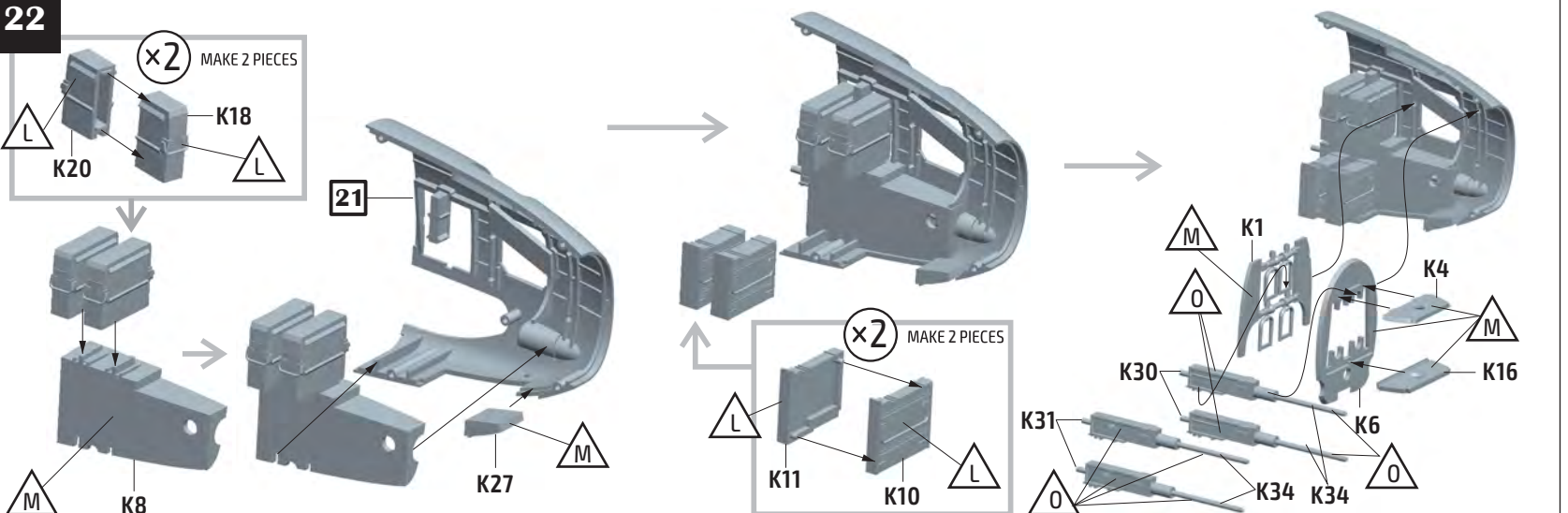







27

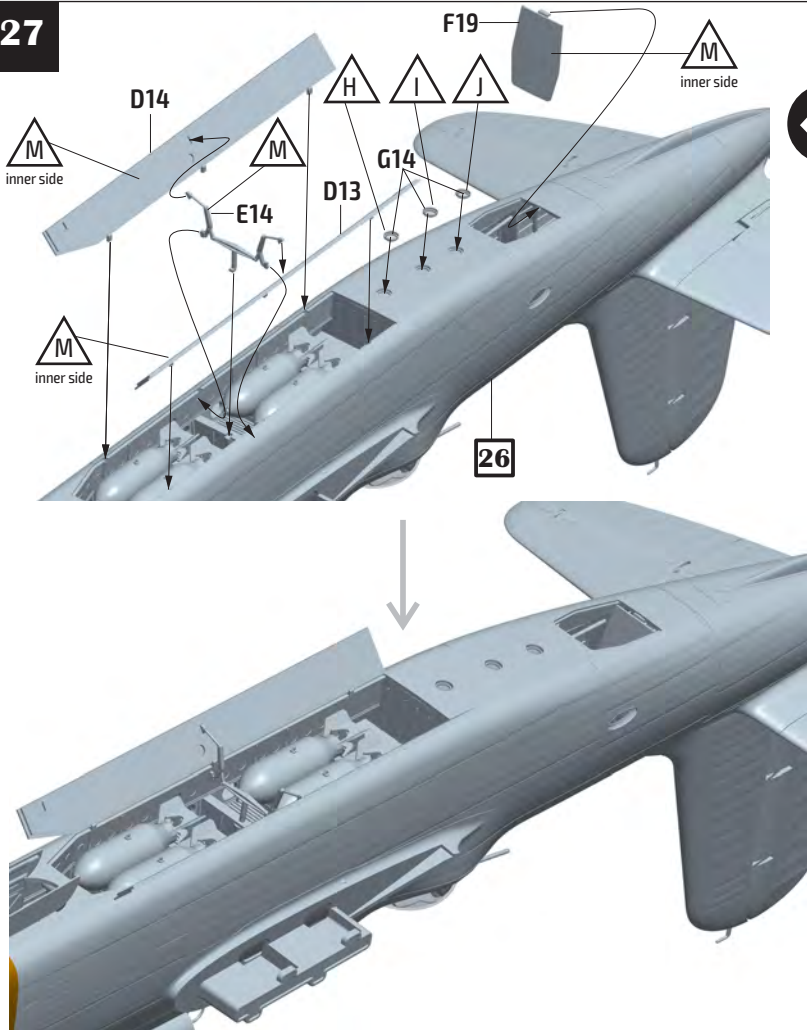

27-1

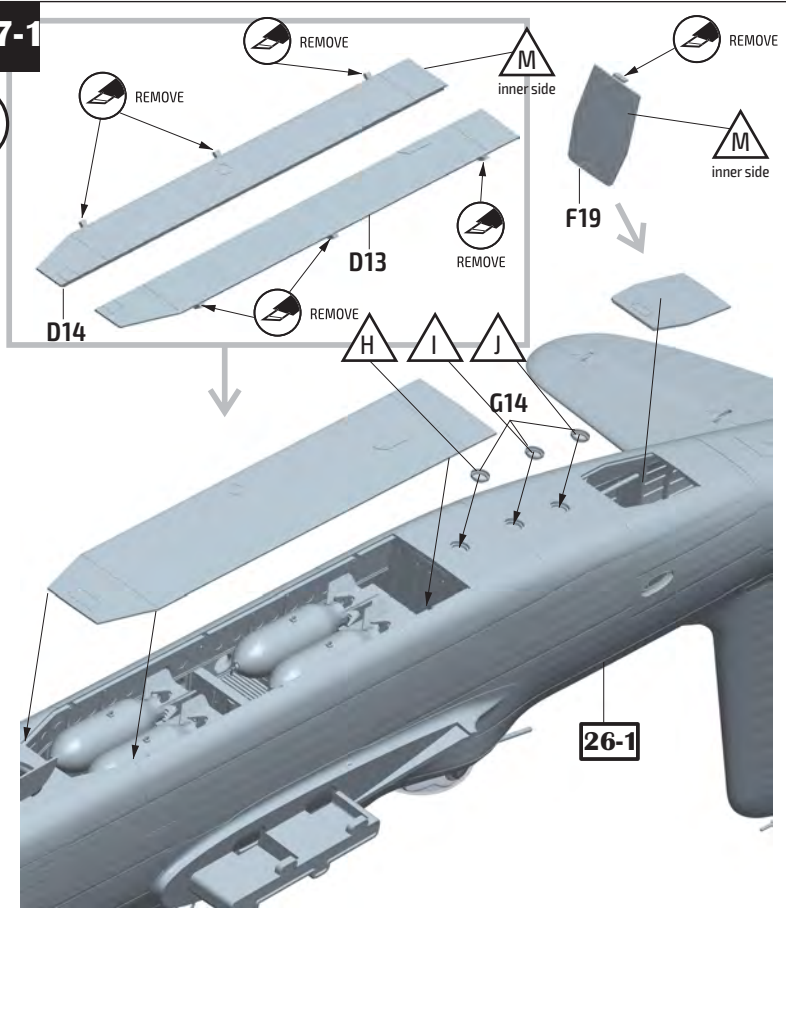

28

x2 MAKE 2 PIECES

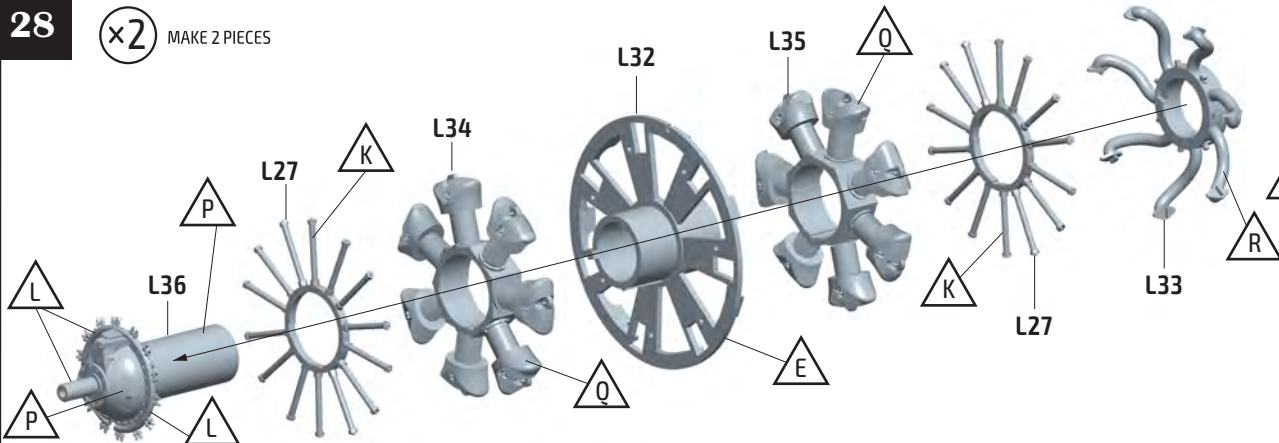

29

Please note the positions of part

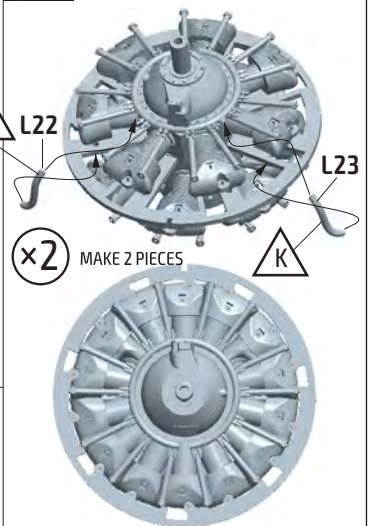

Top roll of cylinders

31

Push rod cover assembly (Front)

Push rod cover assembly (Back)

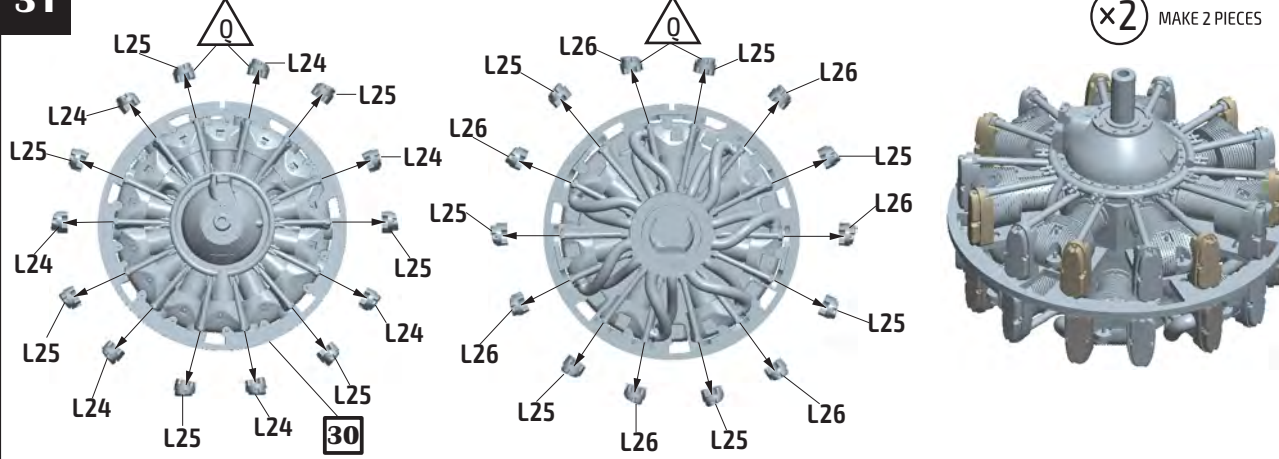

30

Please note the positions of part L31

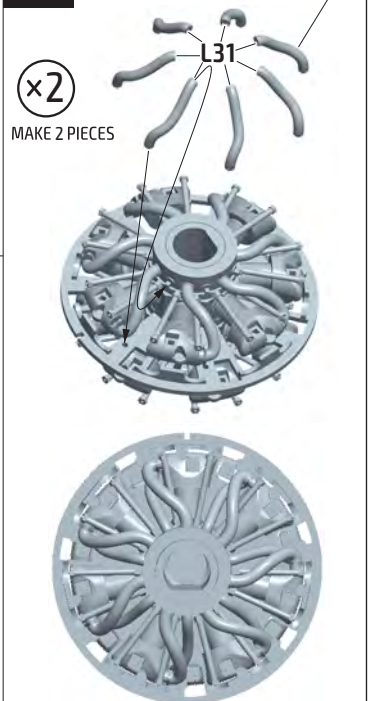

Engine's back

32

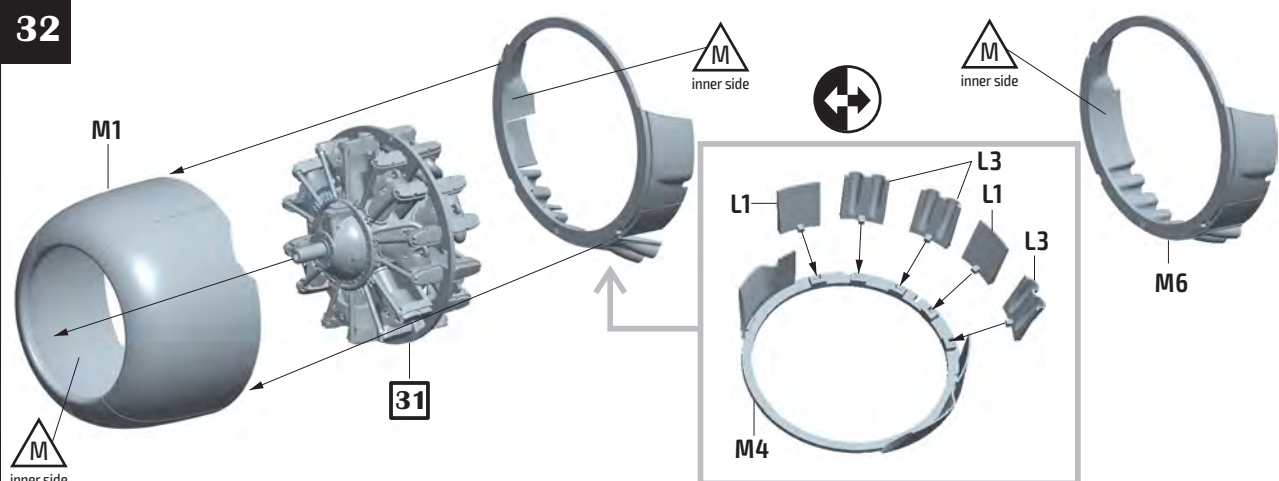



**33** Exhaust stacks assembly

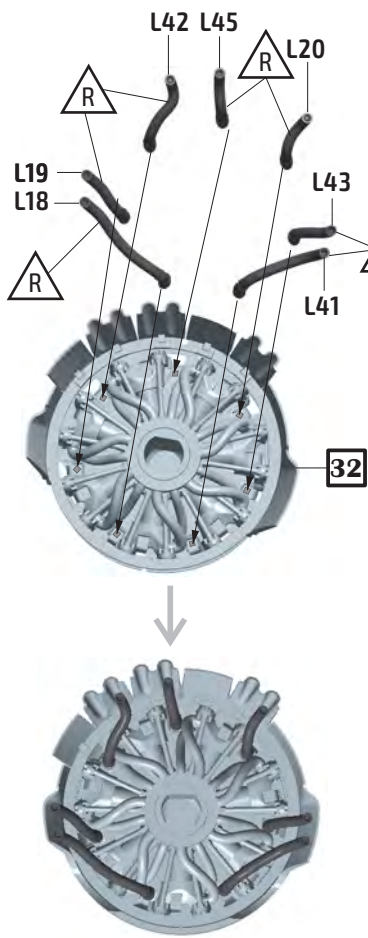

**34** Exhaust stacks assembly

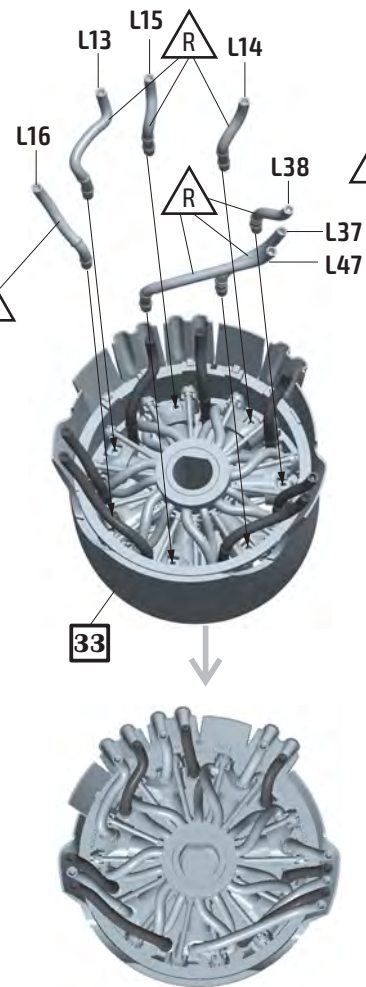

**35**

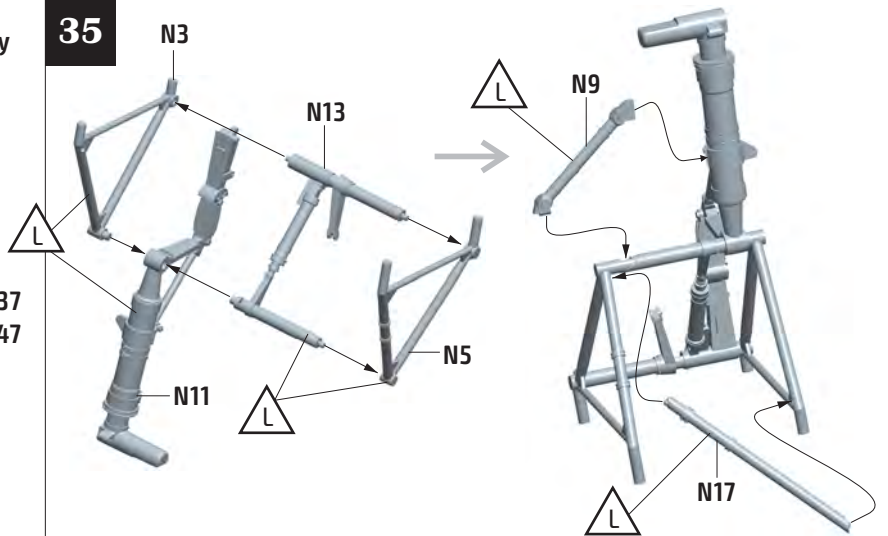

**36**

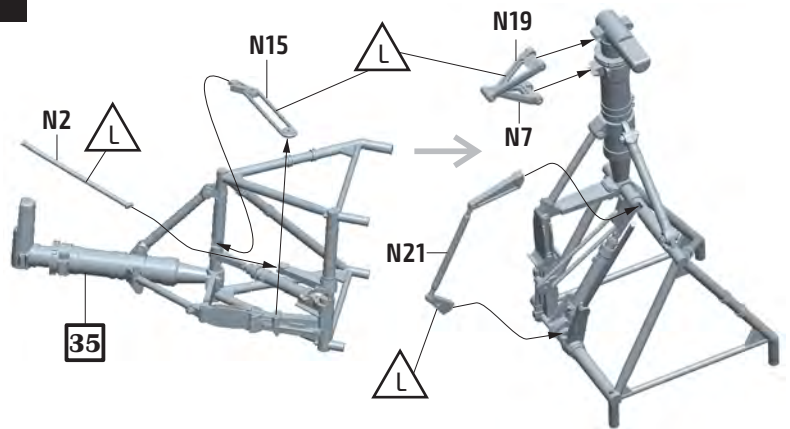

**37**

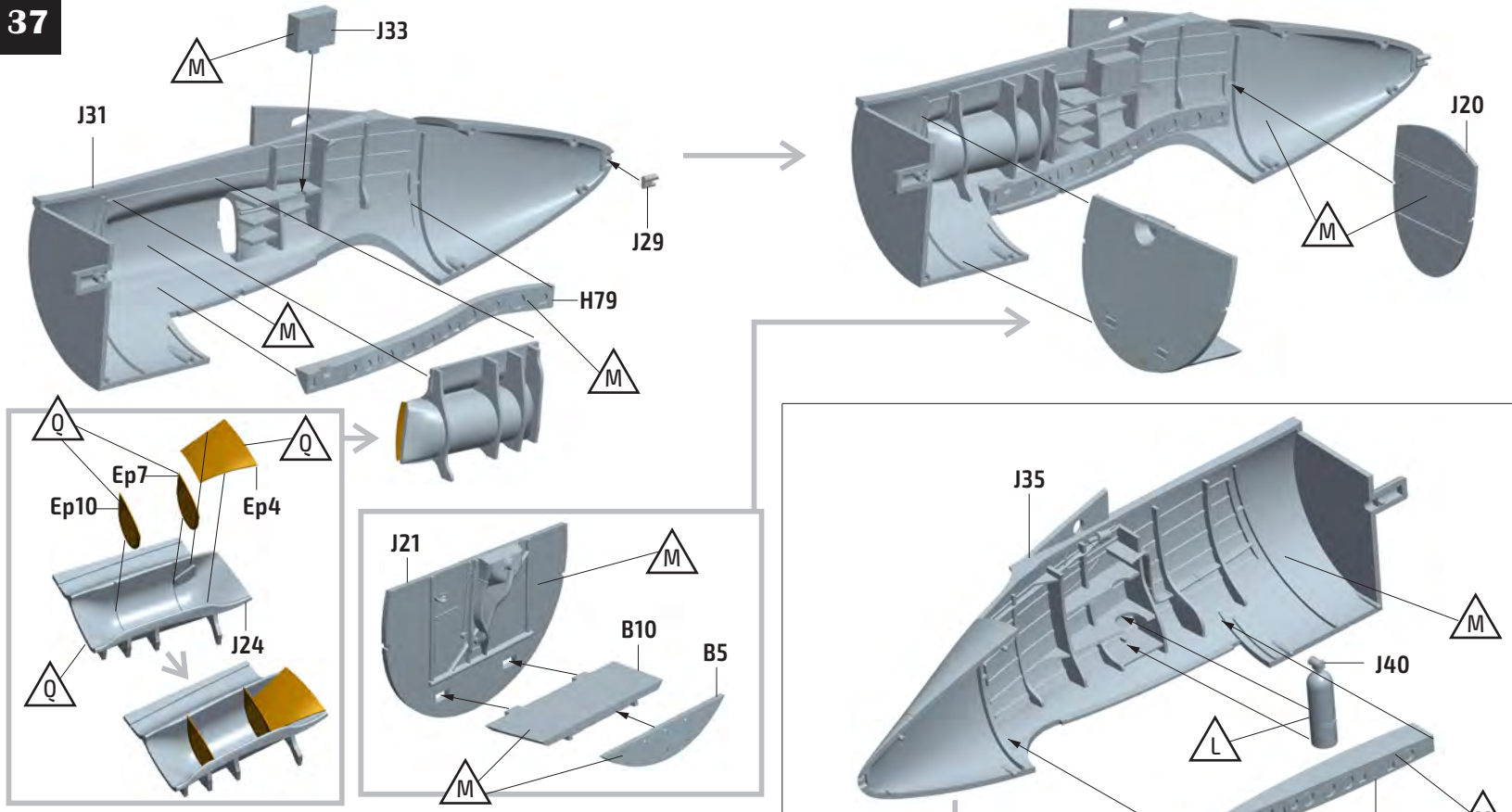

**38**

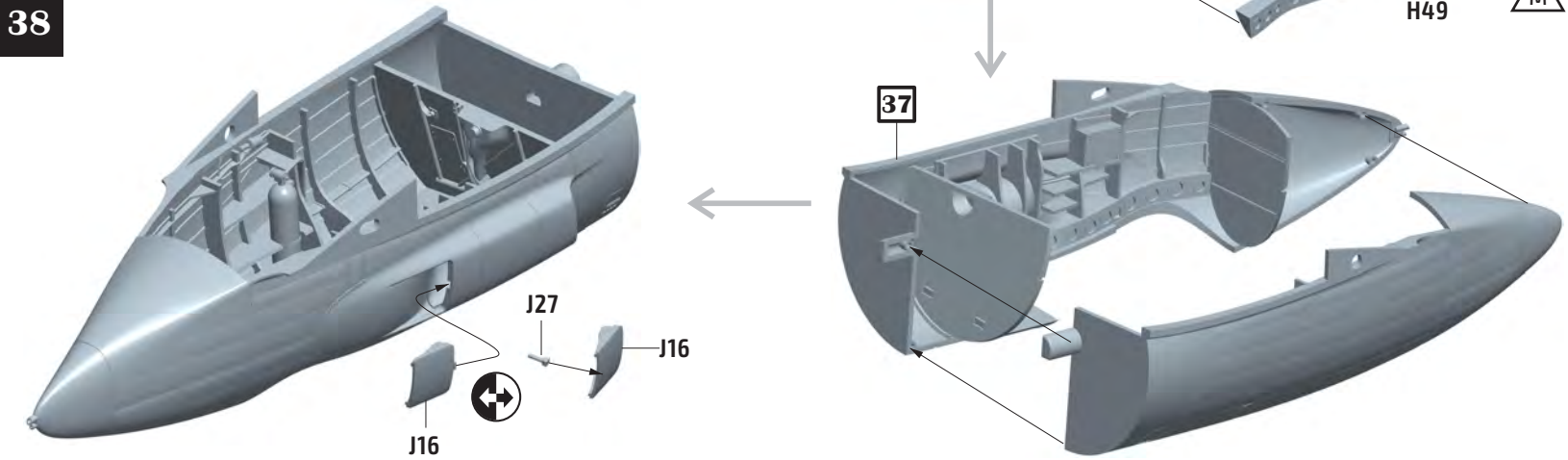



39

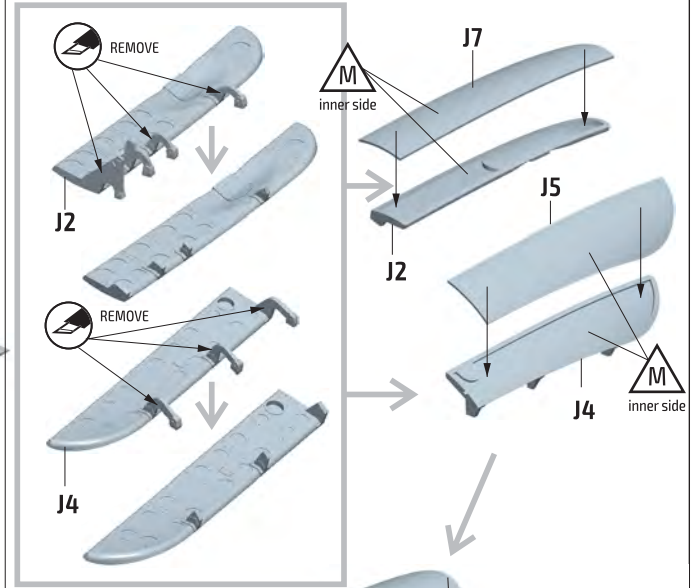
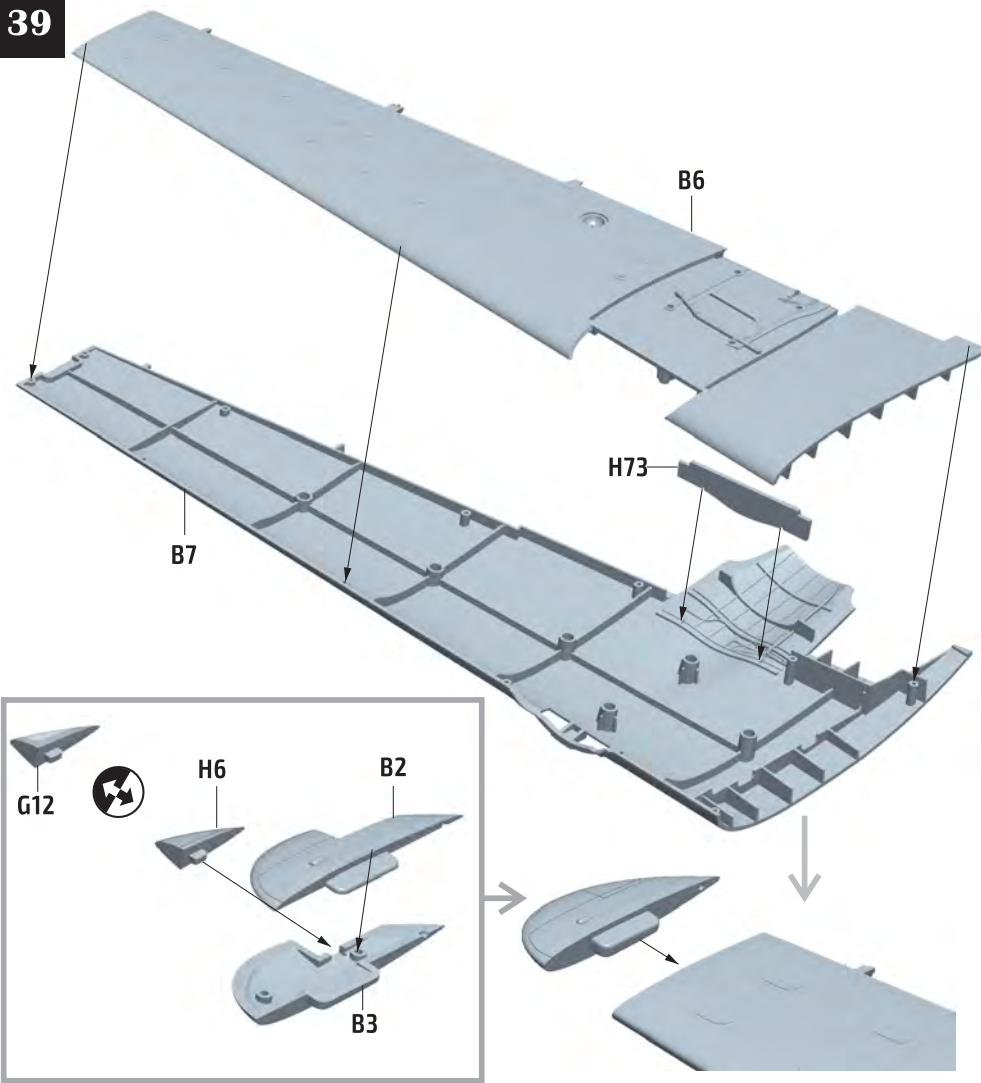

40

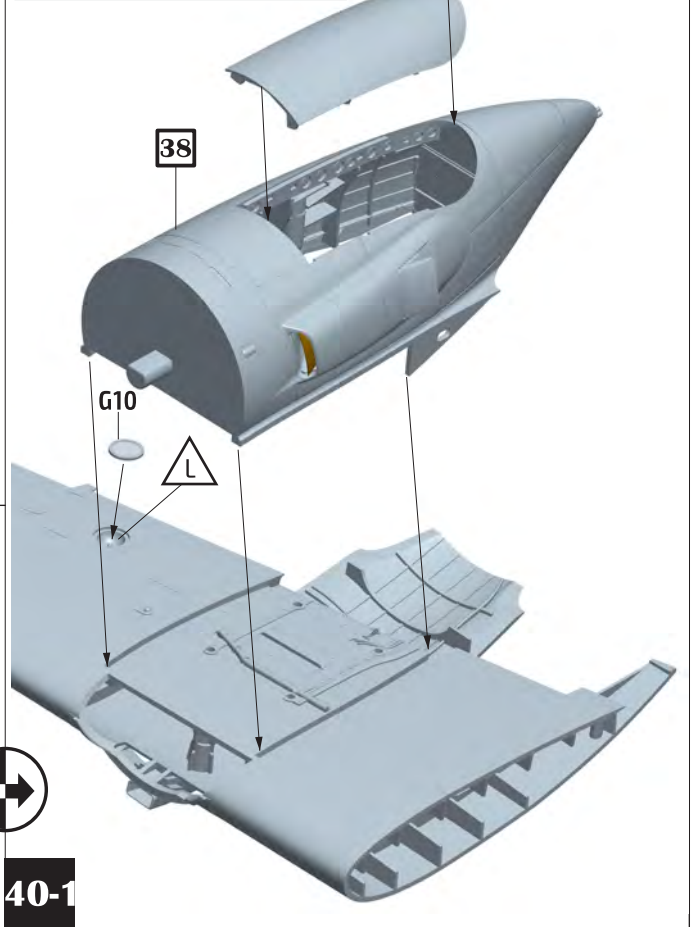
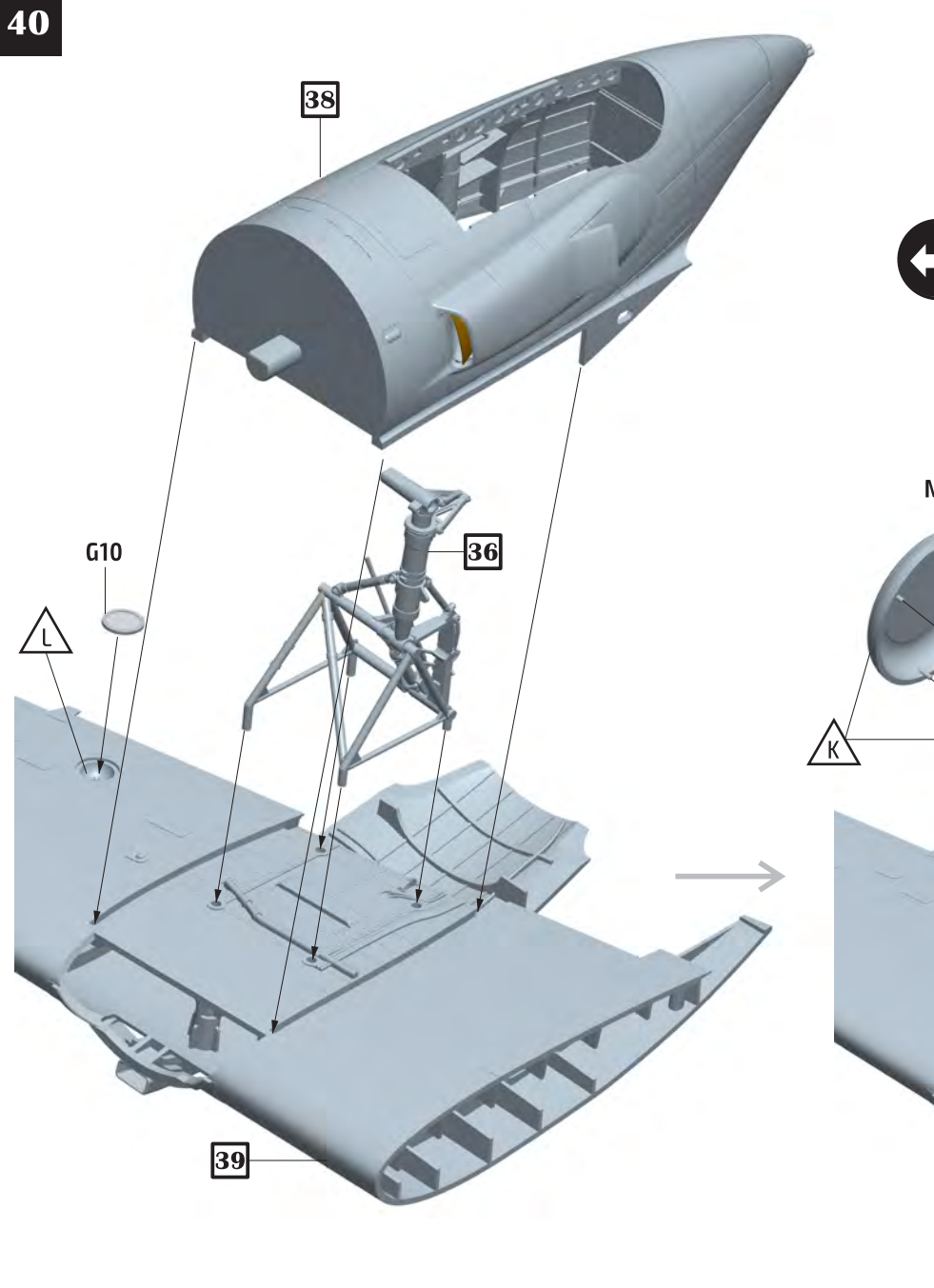

40-1

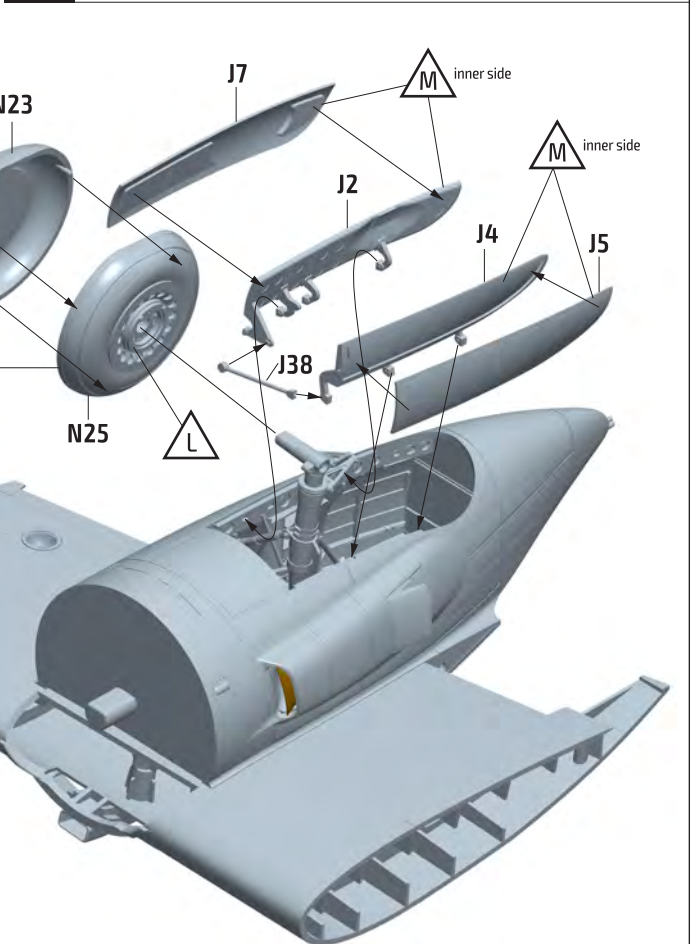



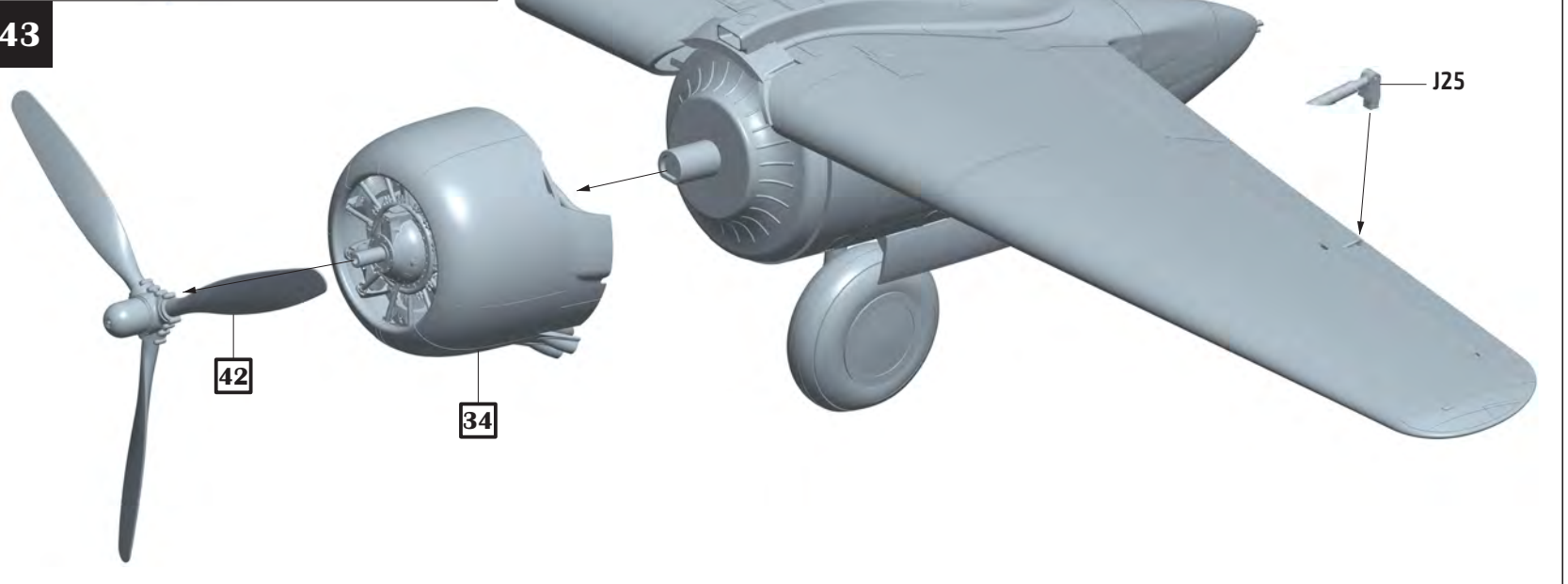
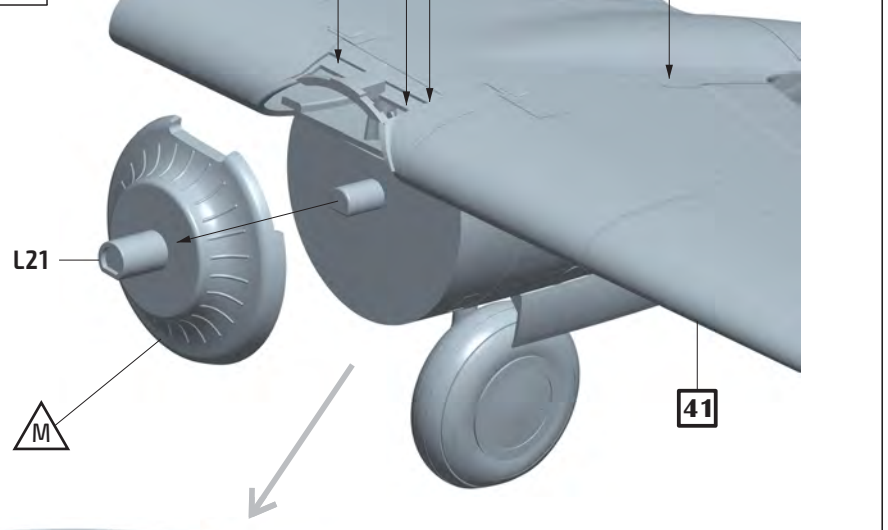
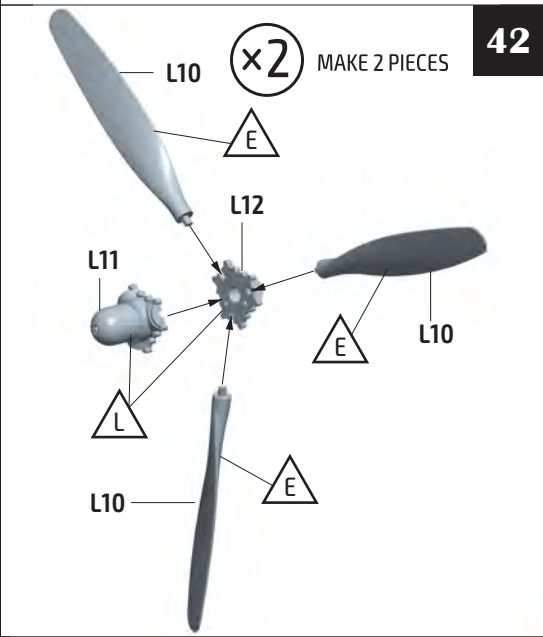
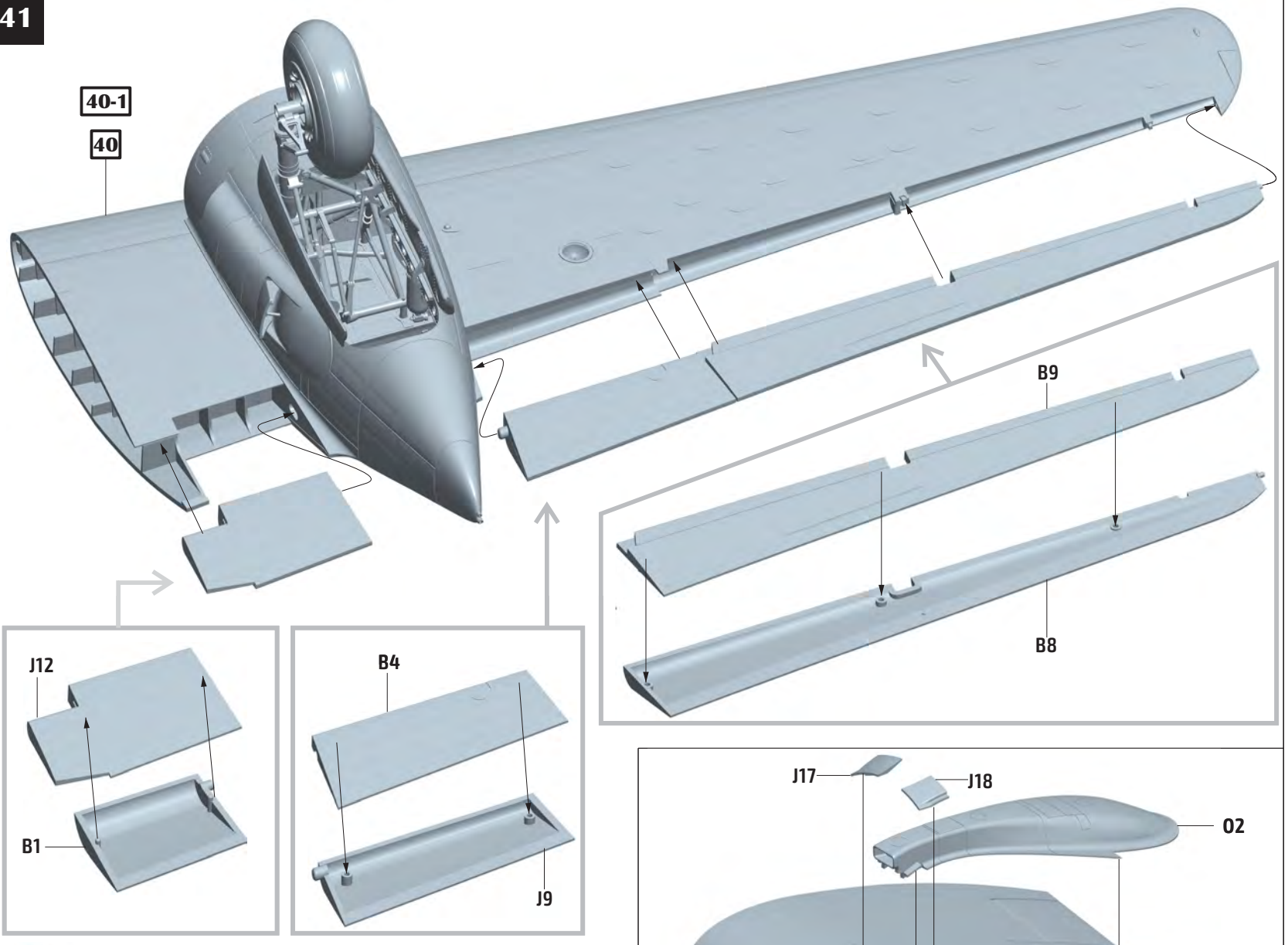







51

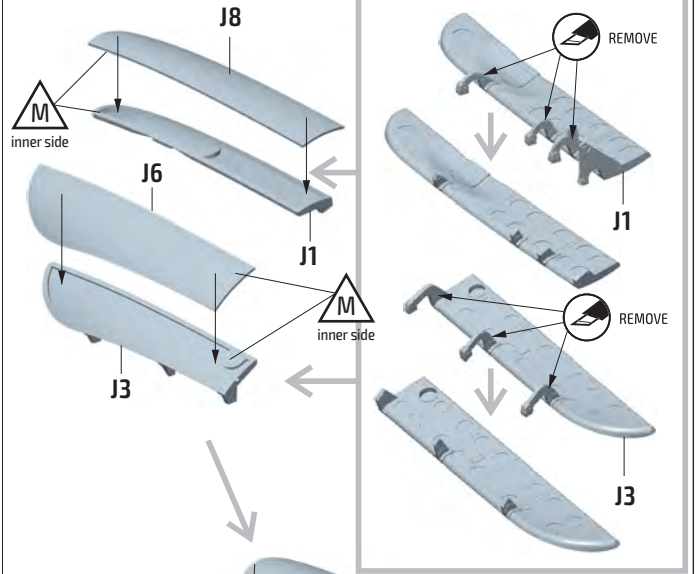
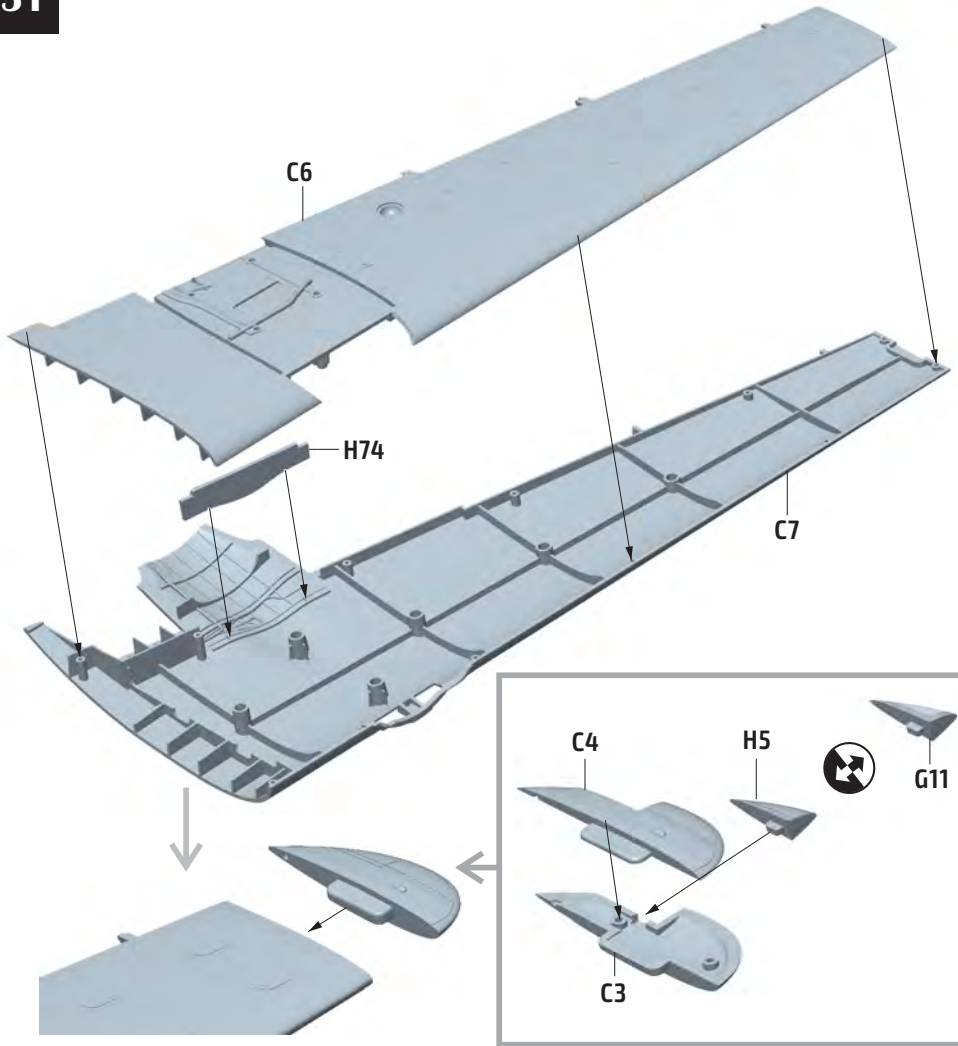

52

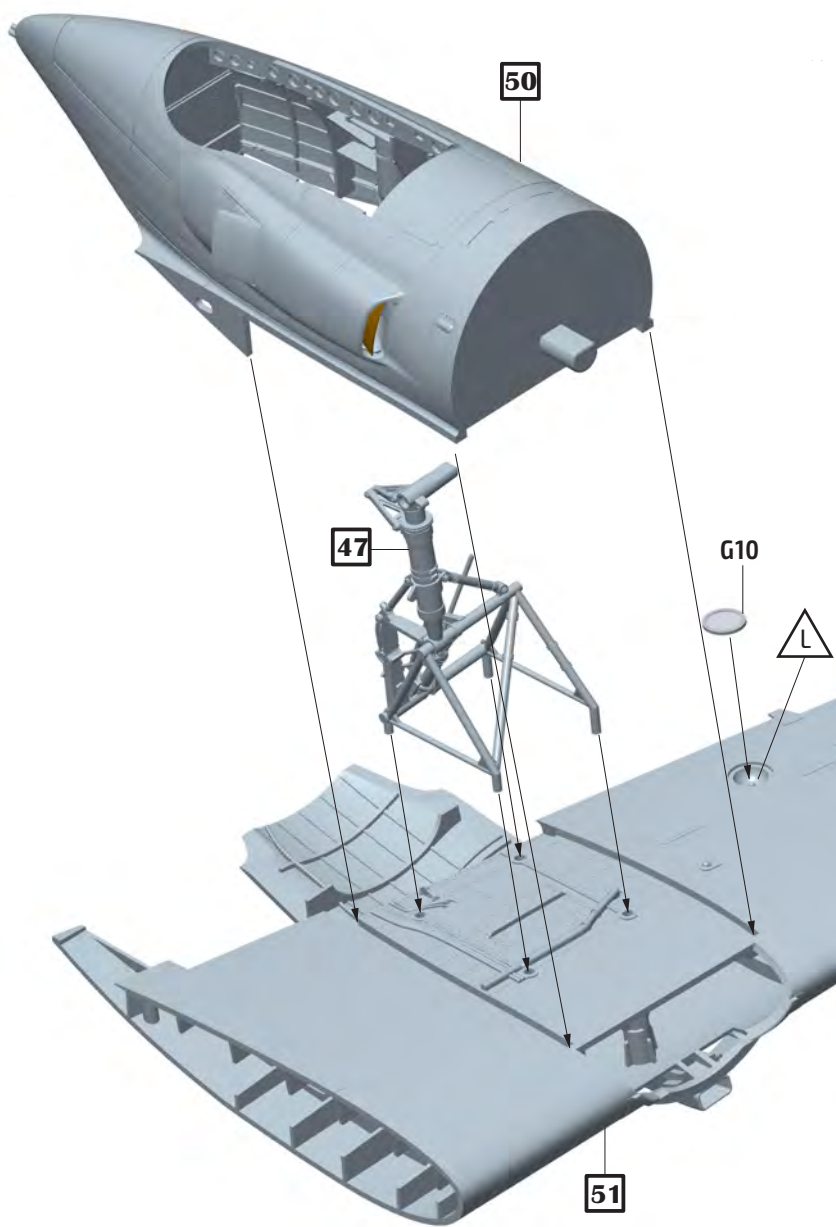

53

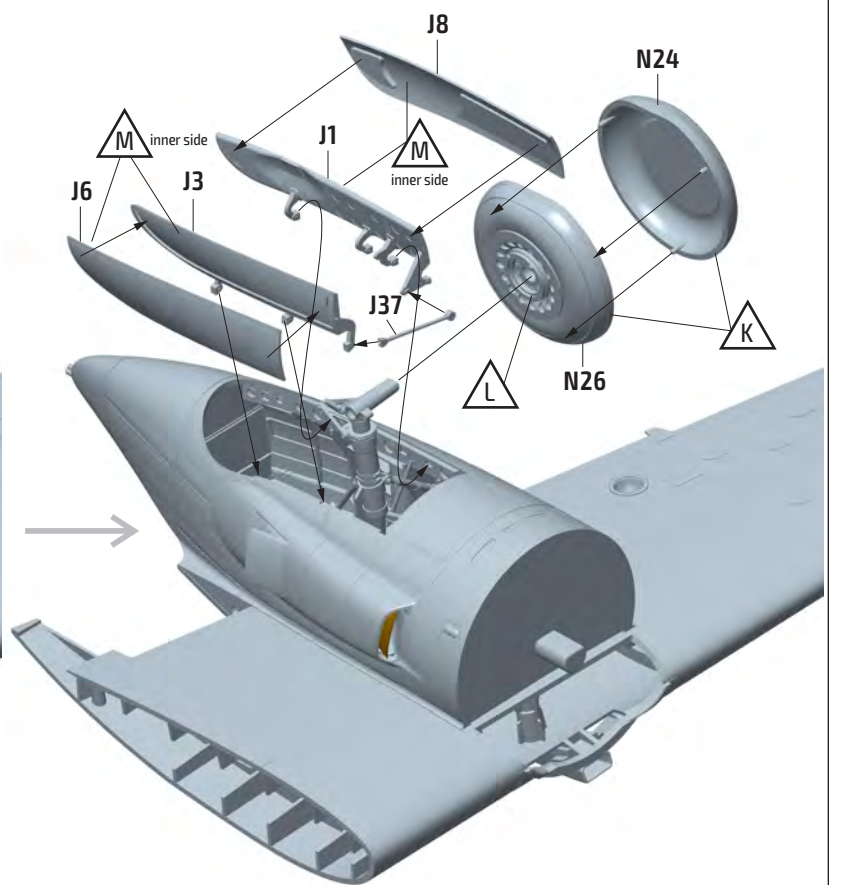
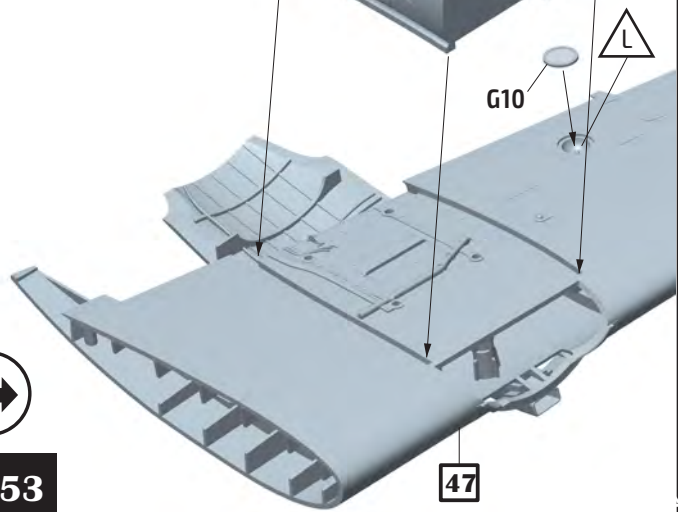



54

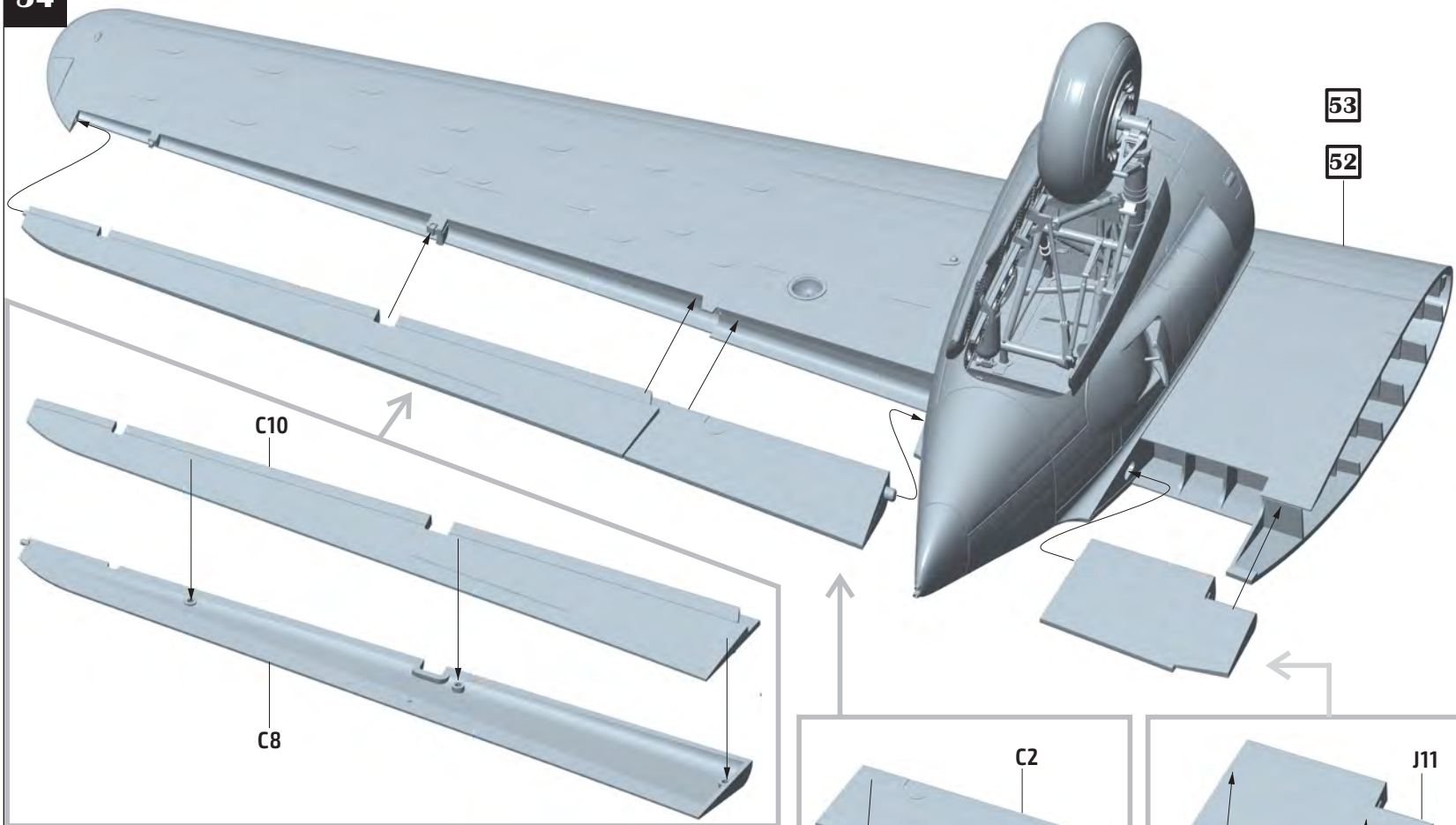

55

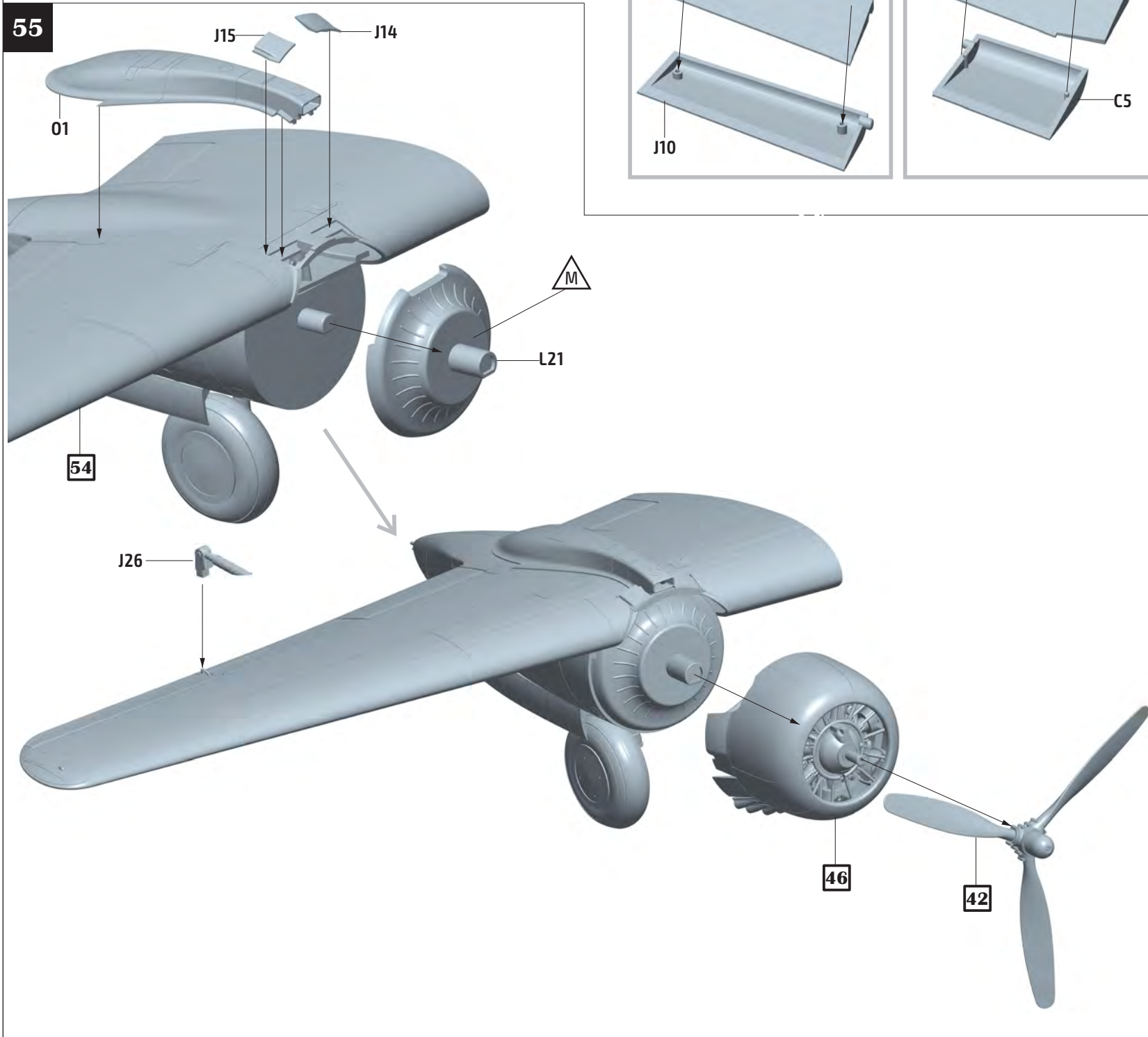



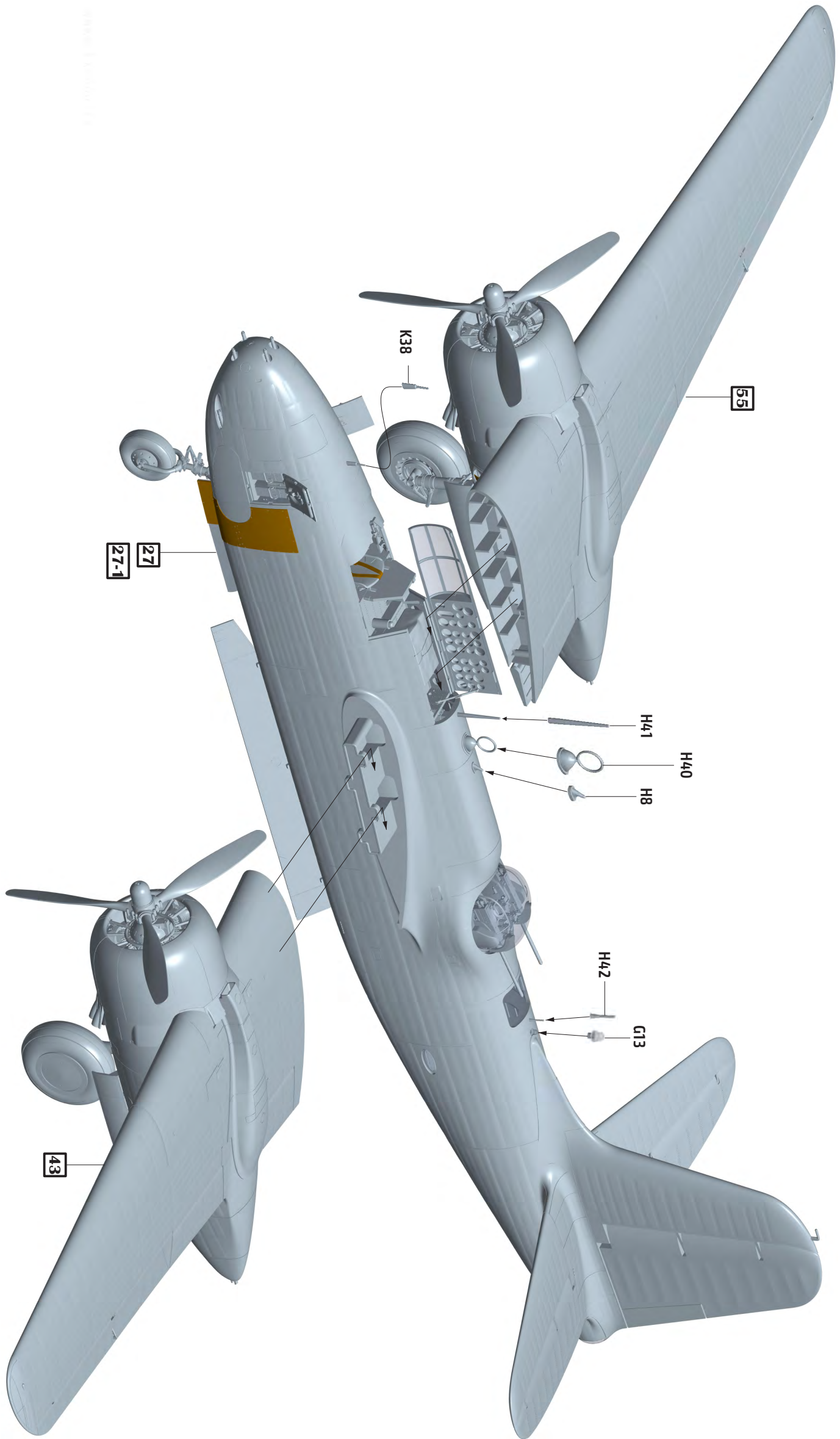



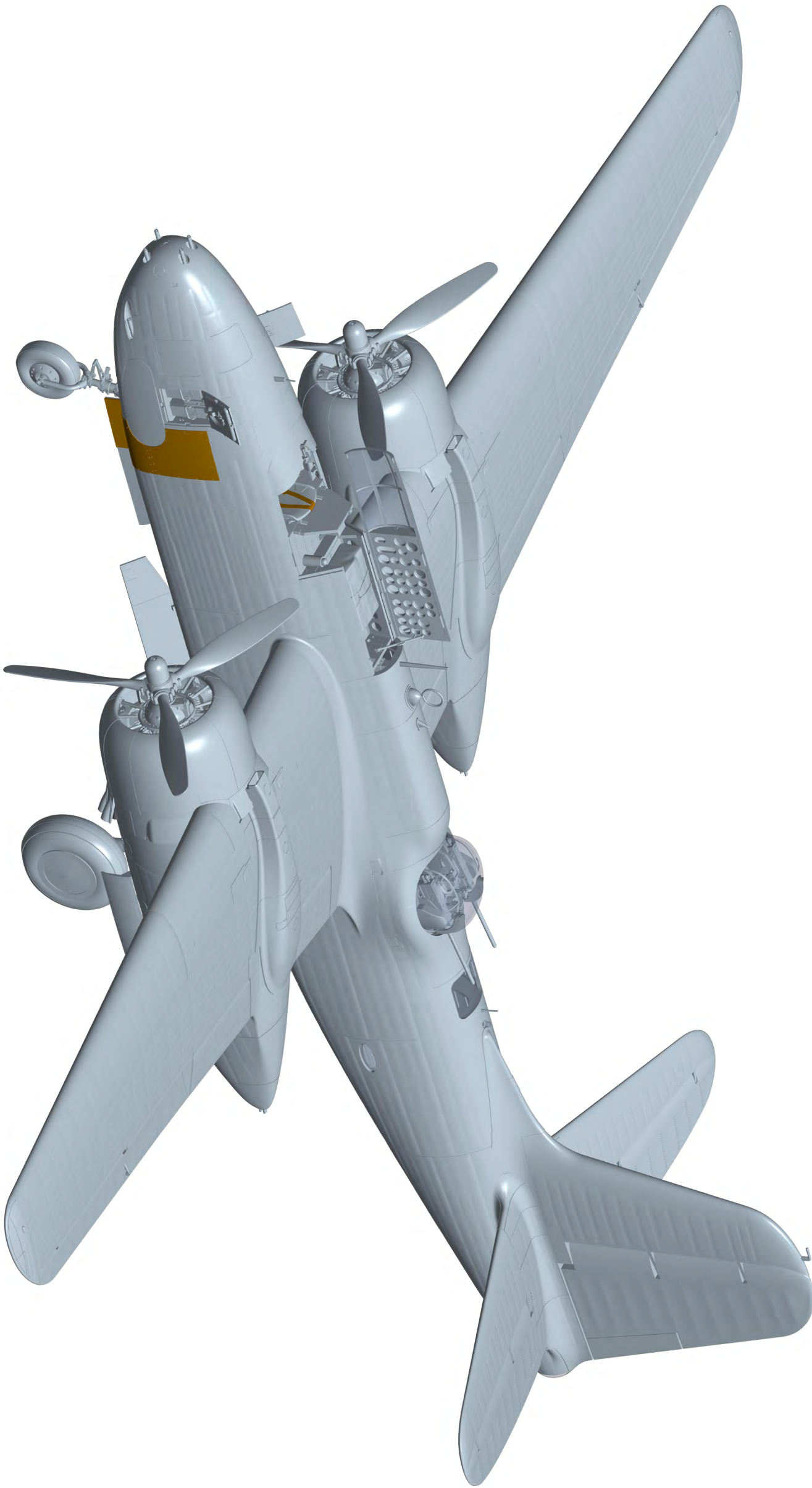



**Parts**

**A PART**

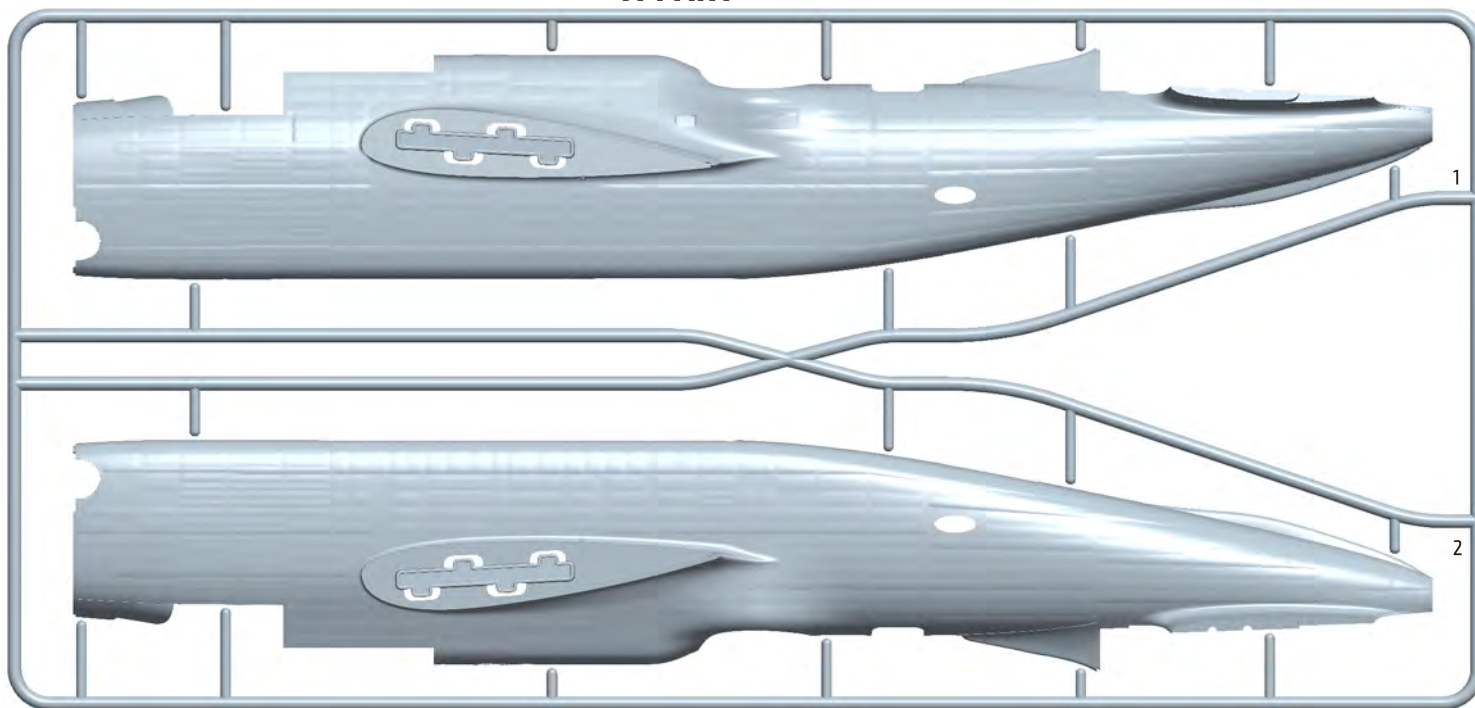

**B PART**

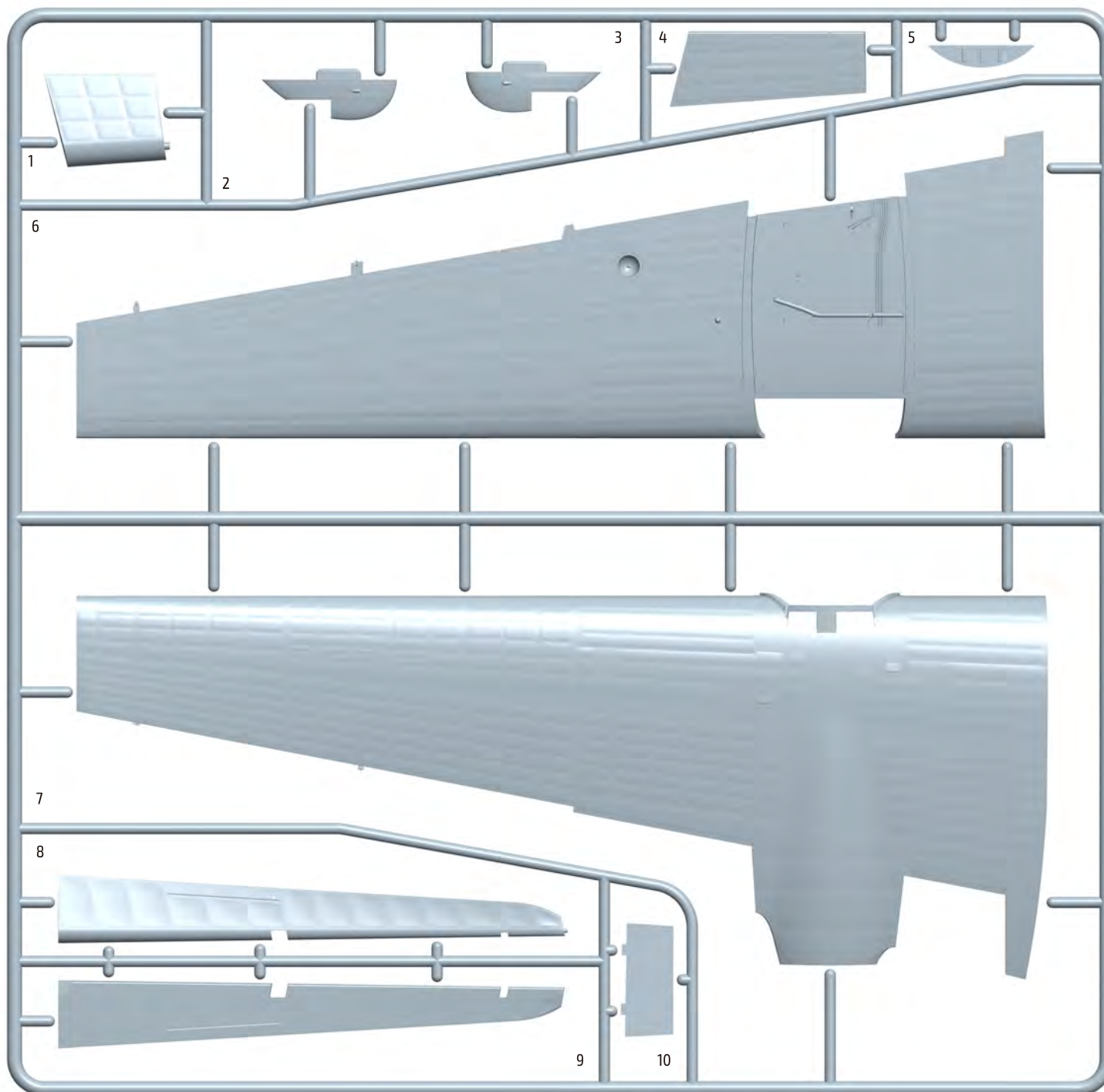



# Parts

D PART

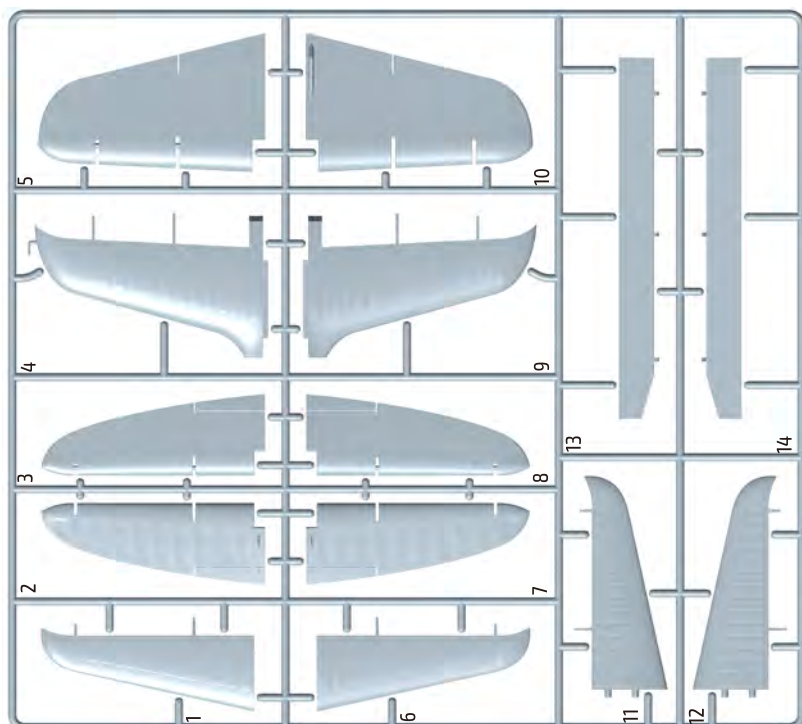

E PART

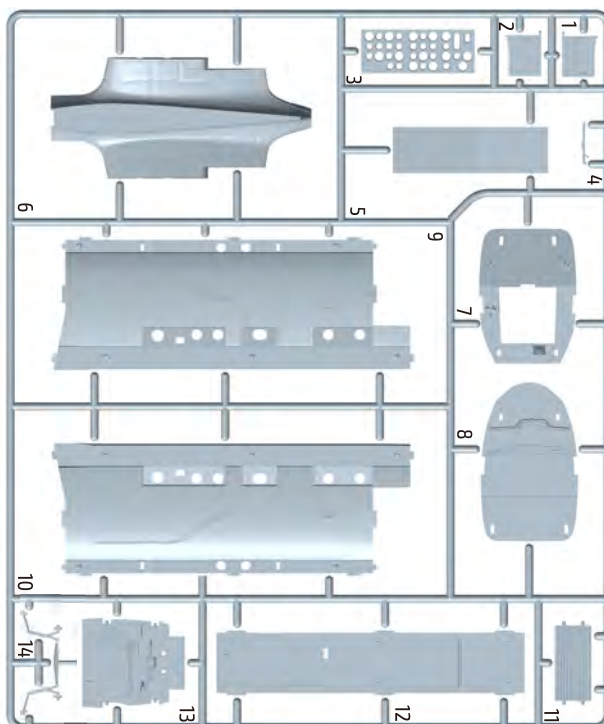

C PART

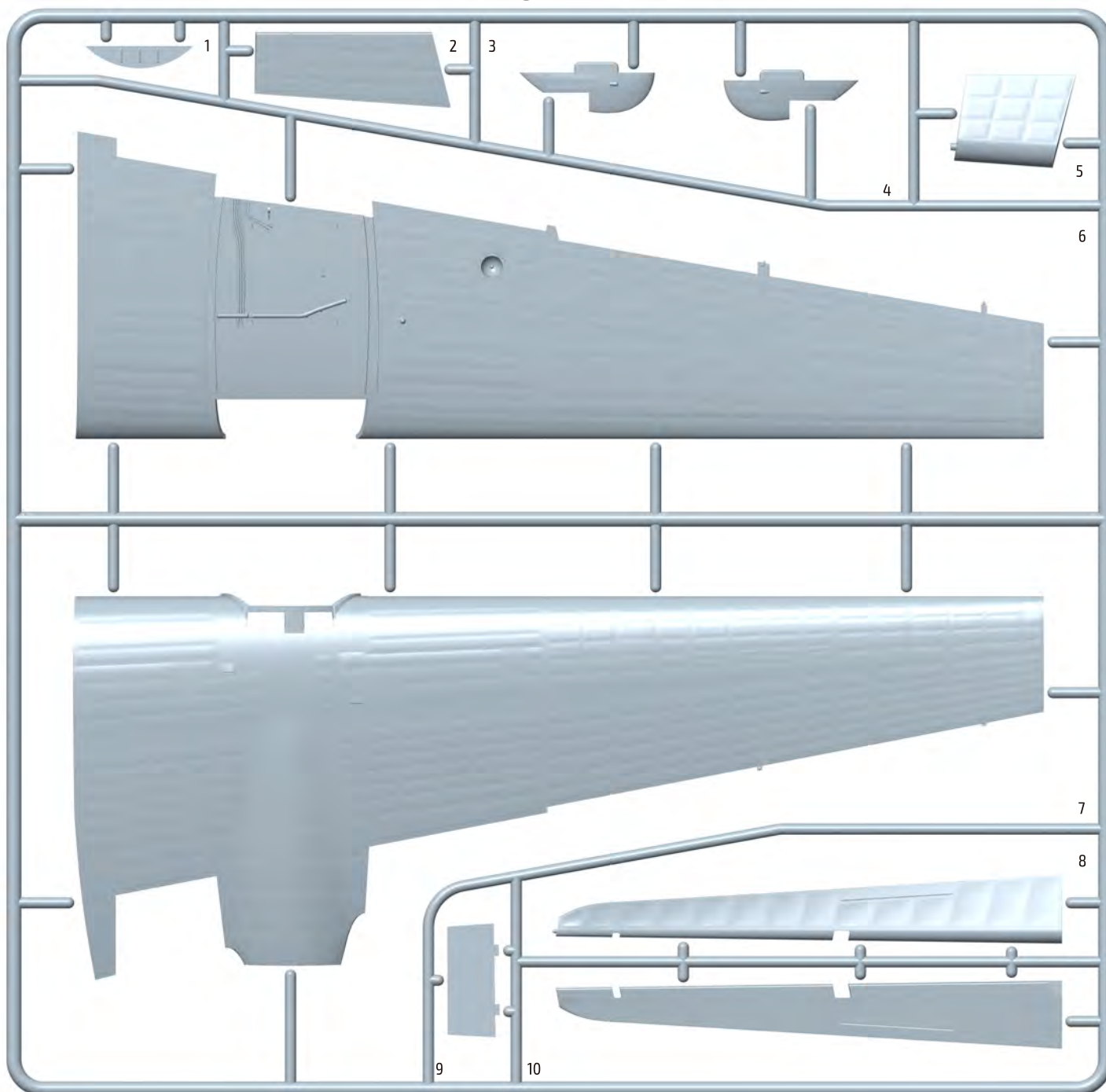



# Parts

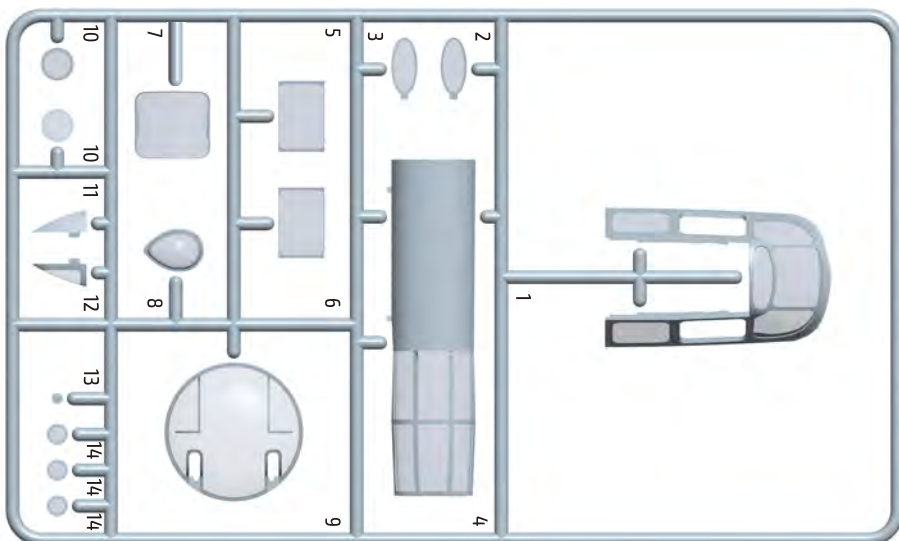
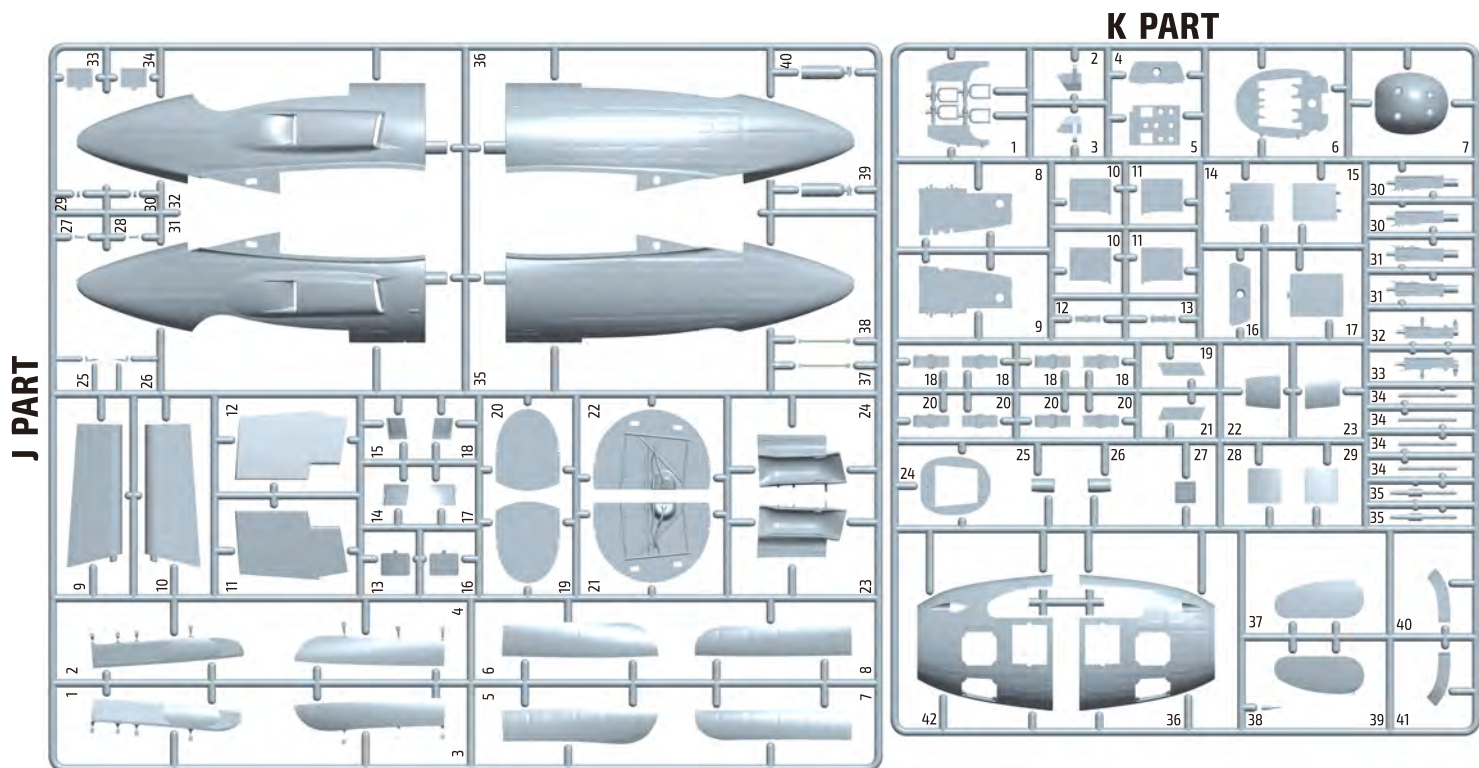
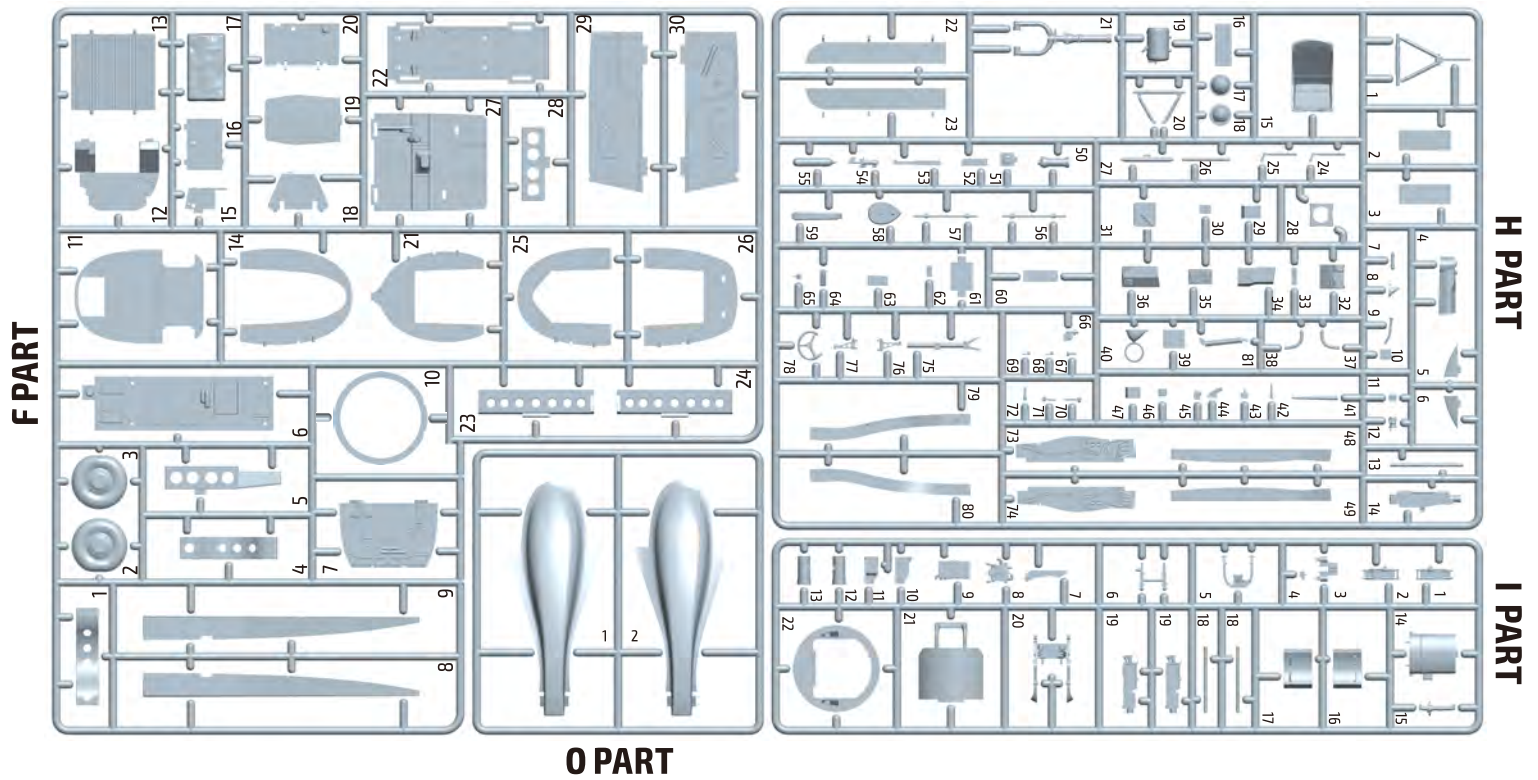

## Photo-etched Parts

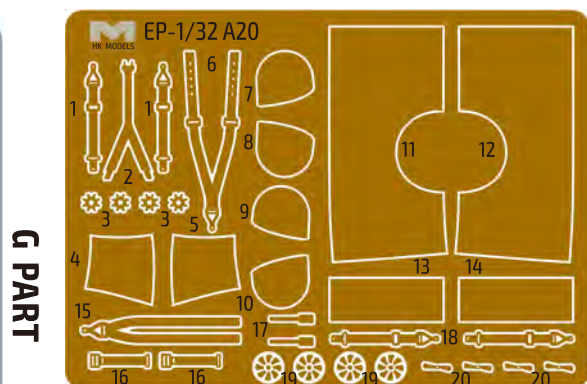

1/32 A20  
W1



1/32 A20  
W2





# Parts

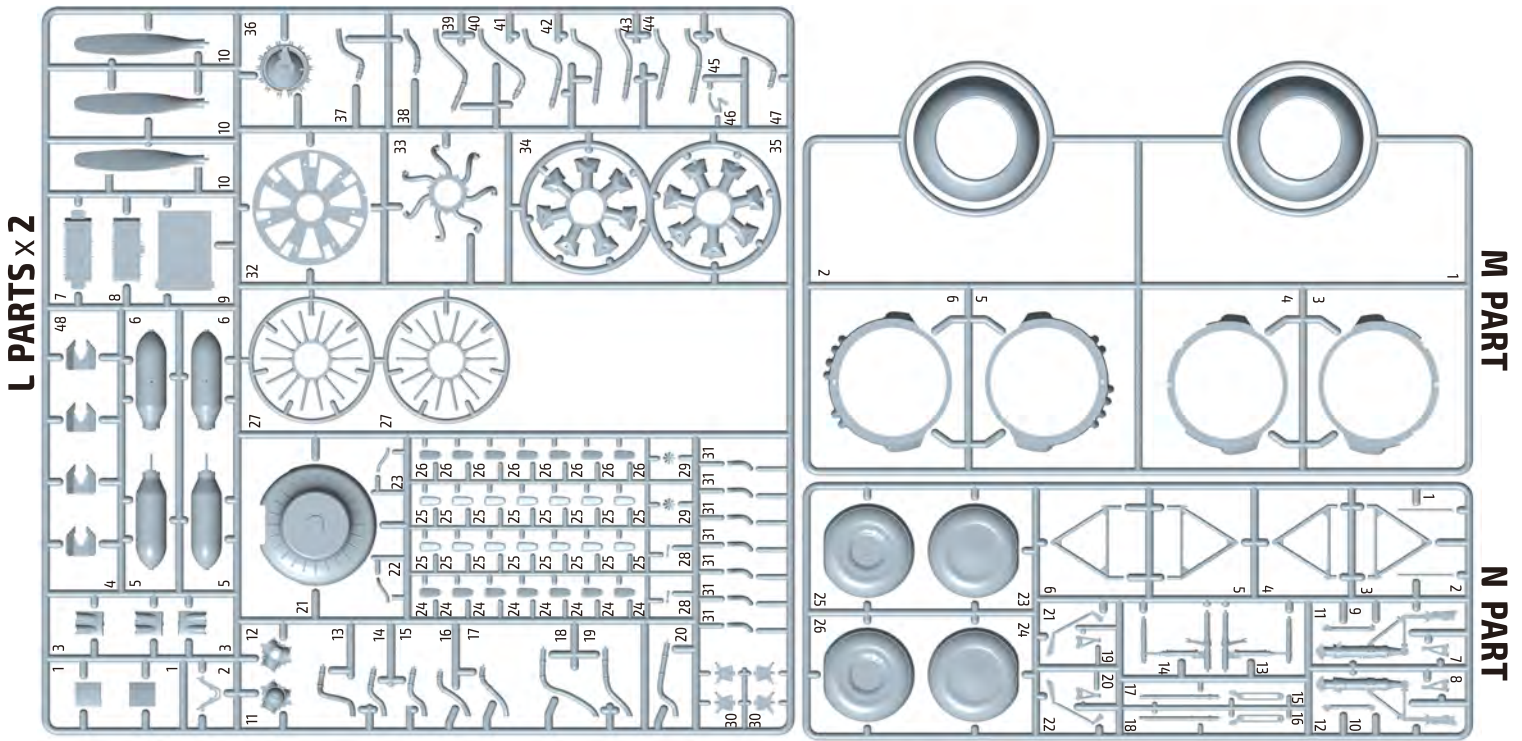

# Decals

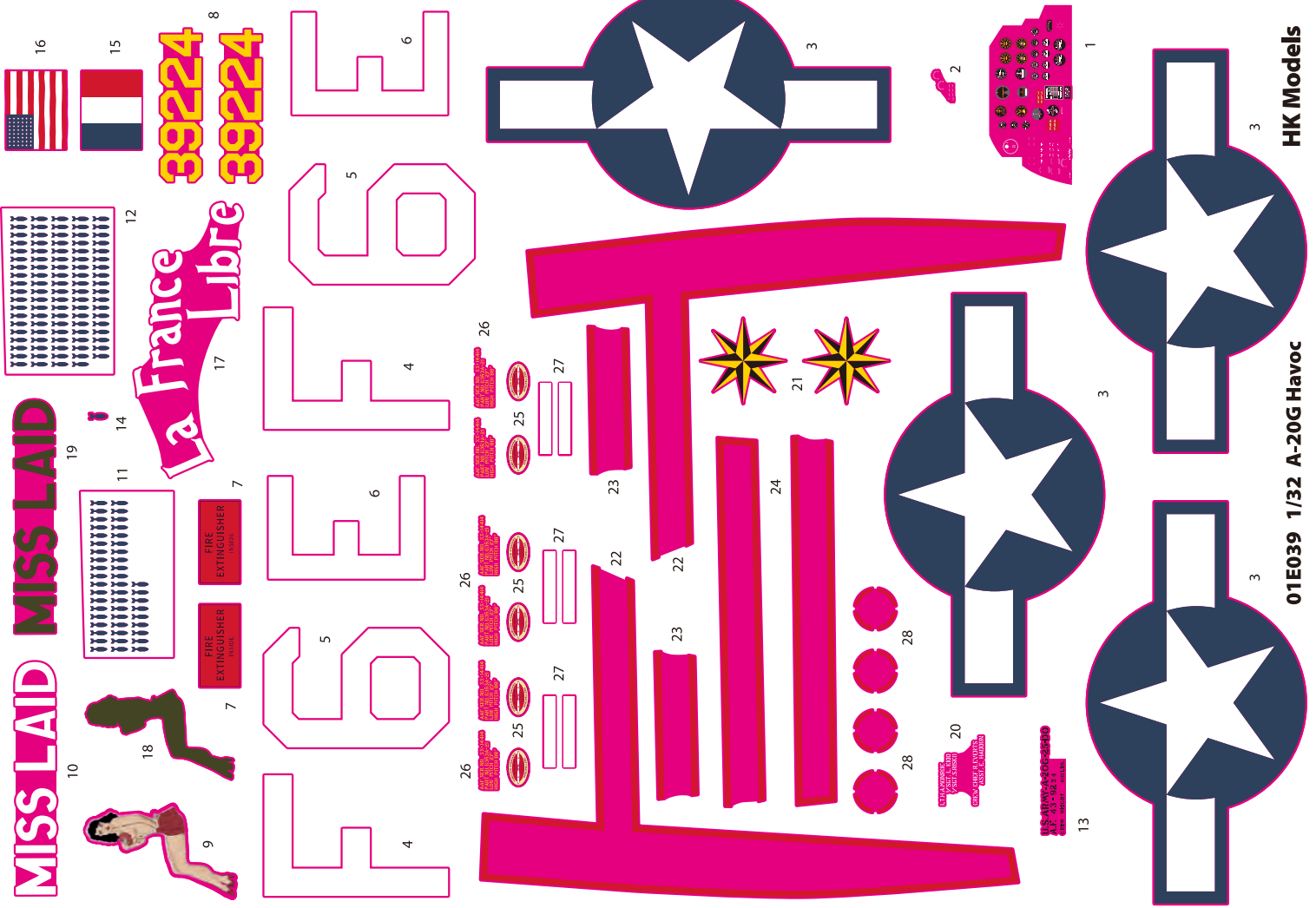

MARKING

A

A-20G-25-DO, s/n 43-9224, 670th BS/416th BG, Wethersfield, UK, 20th June 1944

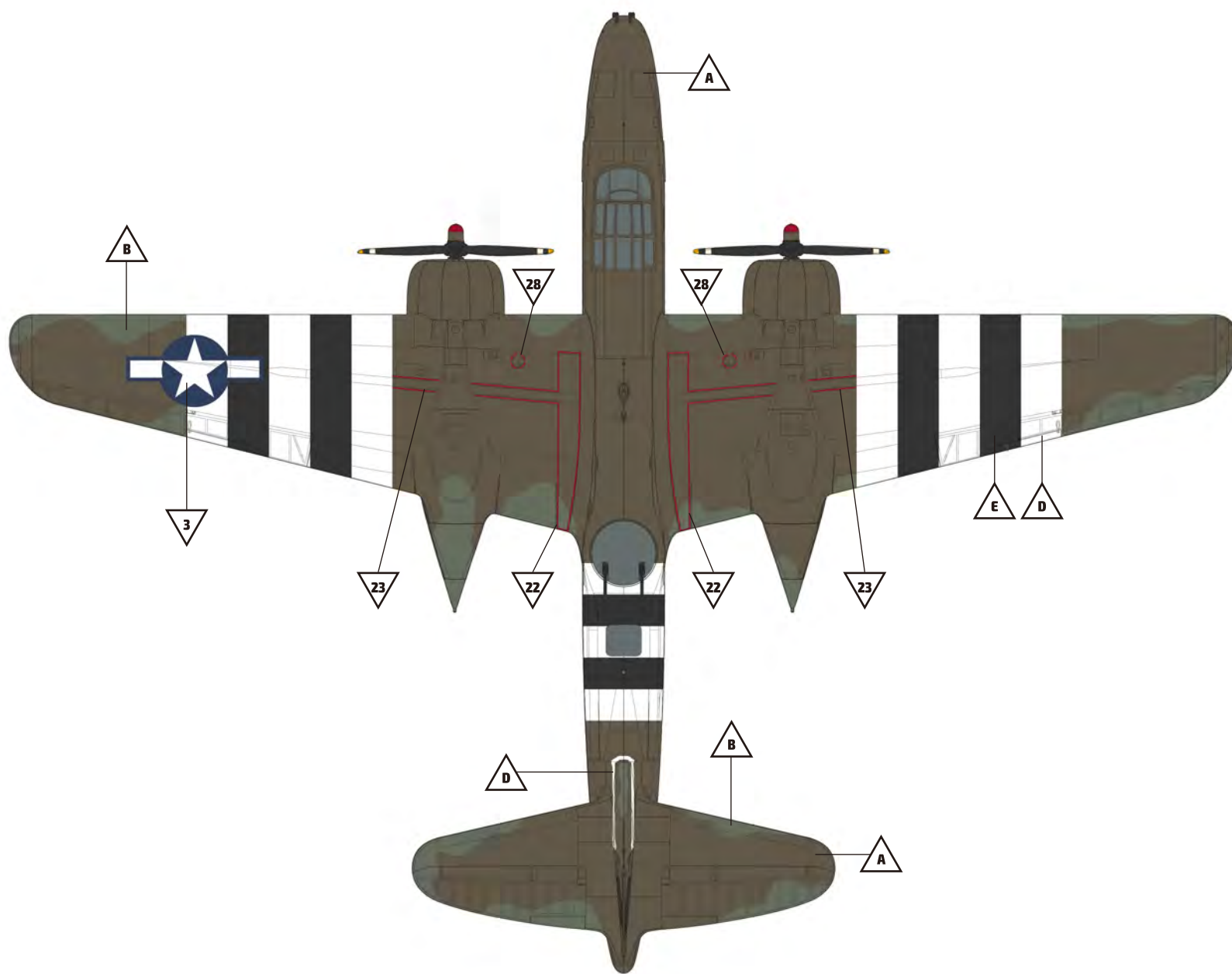
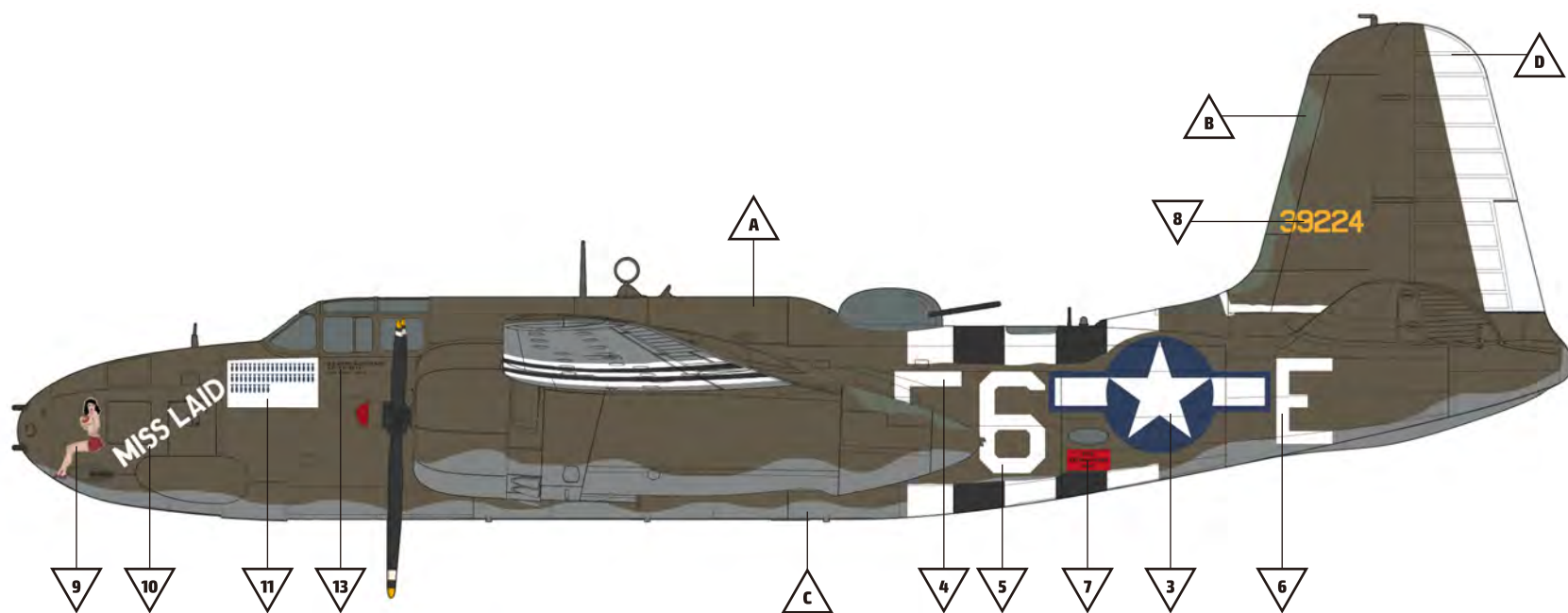



# MARKING

# A

A-20G-25-DO, s/n 43-9224, 670th BS/416th BG, Wethersfield, UK, 20th June 1944

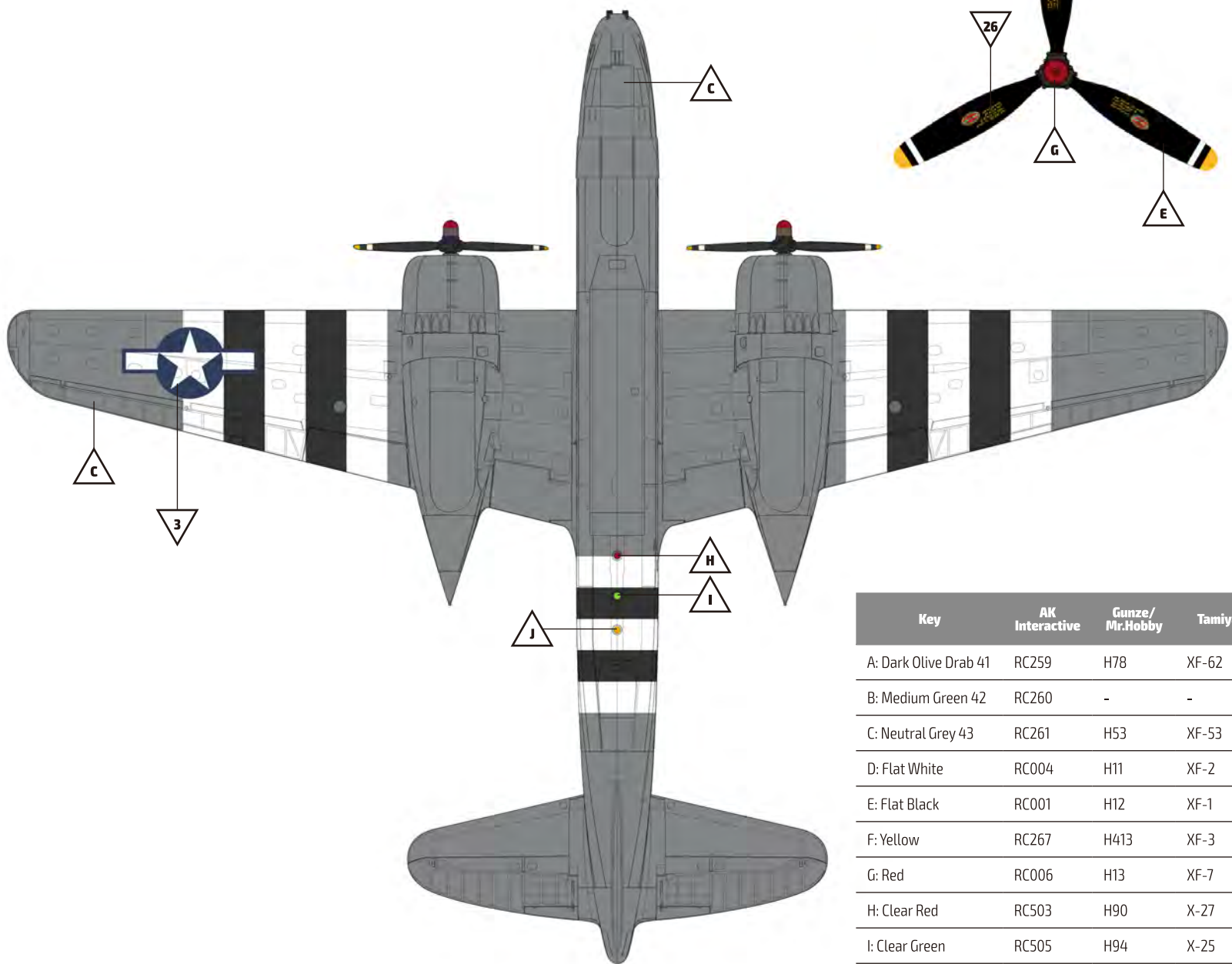
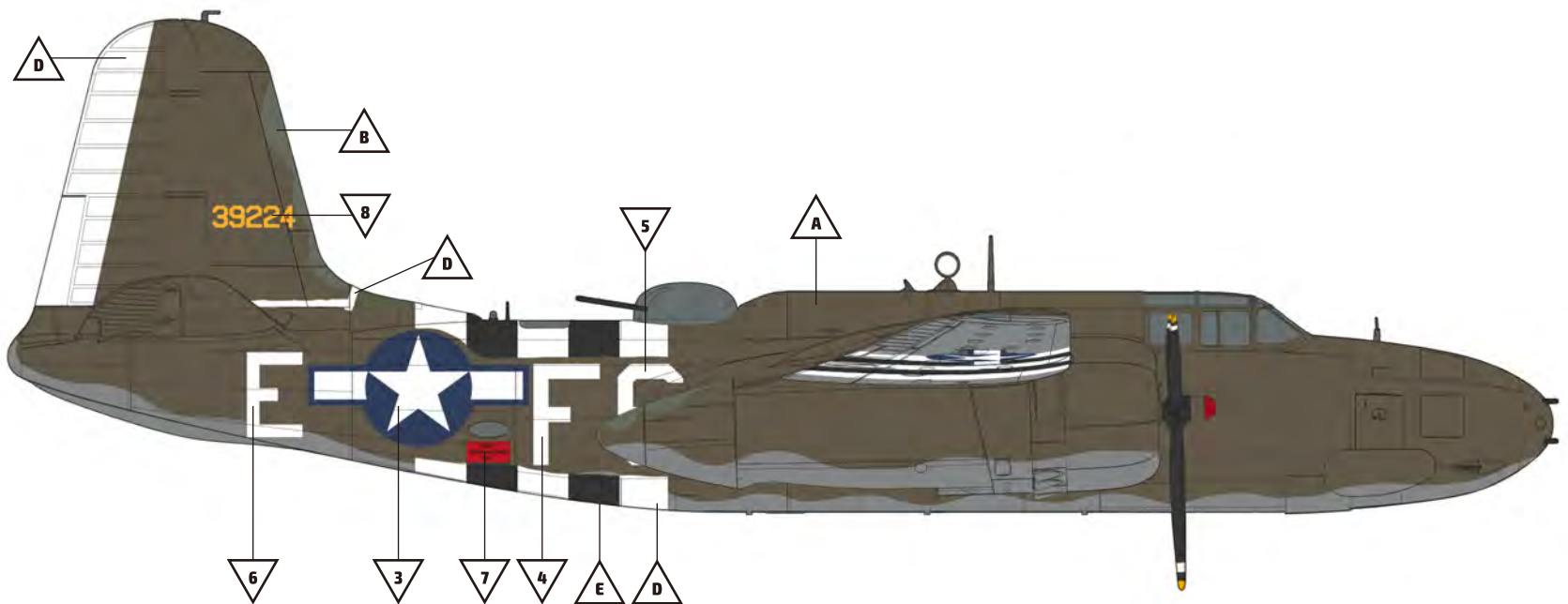

Key	AK Interactive	Gunze/Mr.Hobby	Tamiya
A: Dark Olive Drab 41	RC259	H78	XF-62
B: Medium Green 42	RC260	-	-
C: Neutral Grey 43	RC261	H53	XF-53
D: Flat White	RC004	H11	XF-2
E: Flat Black	RC001	H12	XF-1
F: Yellow	RC267	H413	XF-3
G: Red	RC006	H13	XF-7
H: Clear Red	RC503	H90	X-27
I: Clear Green	RC505	H94	X-25
J: Clear Orange	RC506	H92	X-26

**MARKING**

**B**

**A-20G-25-DO, s/n 43-9224, 670th BS/416th BG, A-55 Melun/Villaroche, France, 5th October 1944**

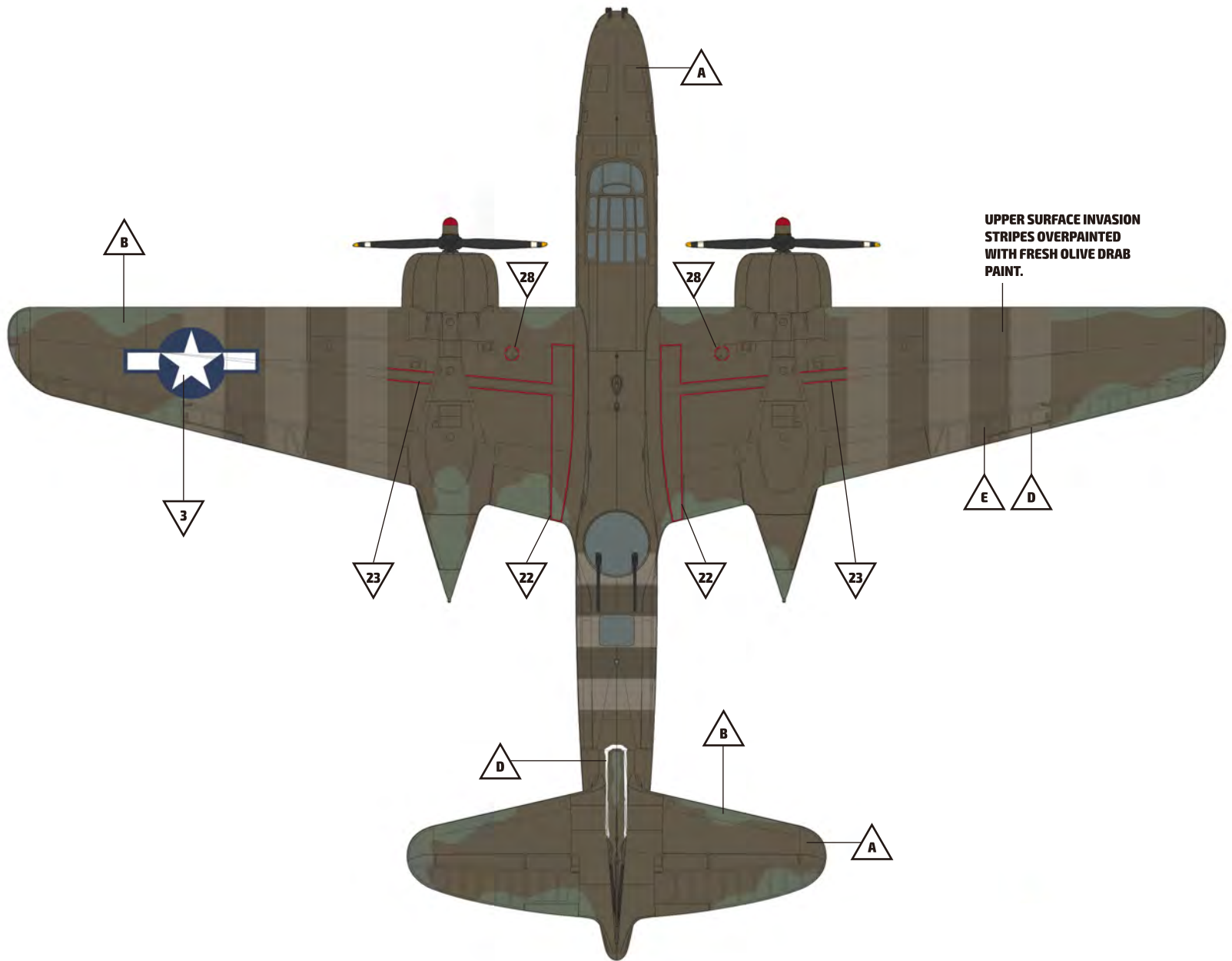
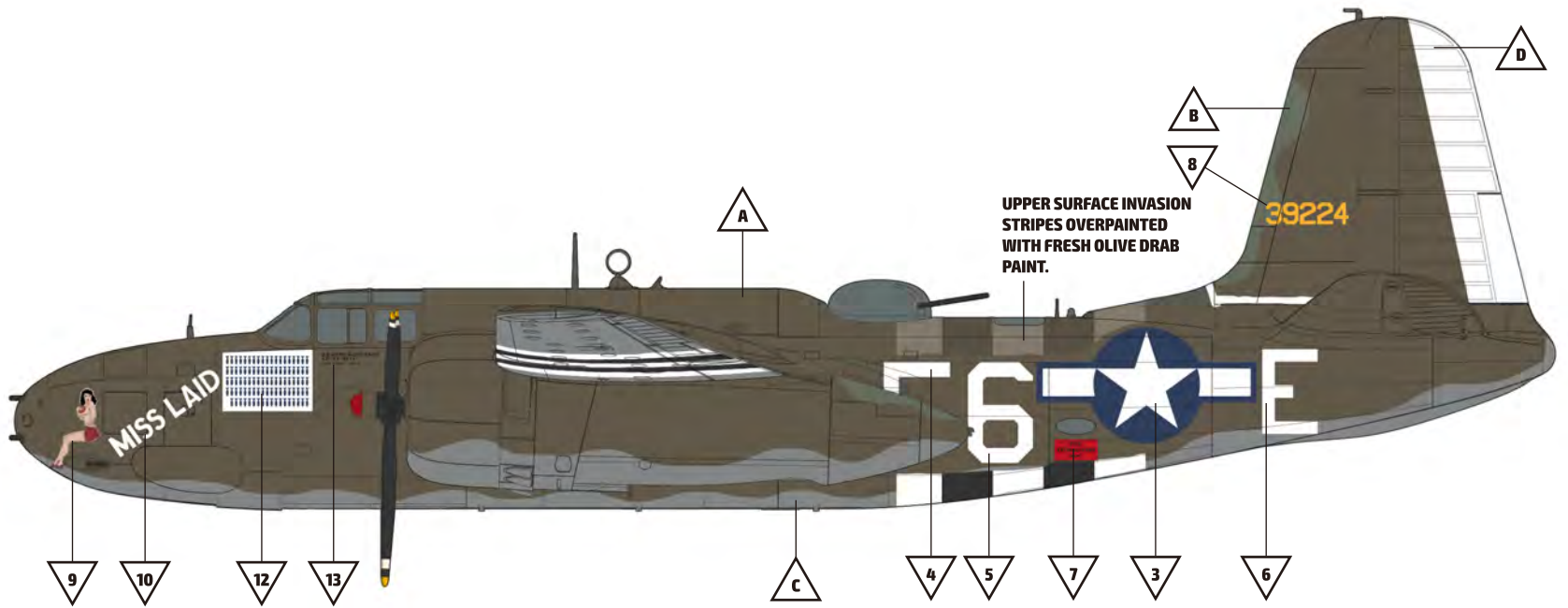



# MARKING

## B

A-20G-25-DO, s/n 43-9224, 670th BS/416th BG, A-55 Melun/Villaroche, France, 5th October 1944

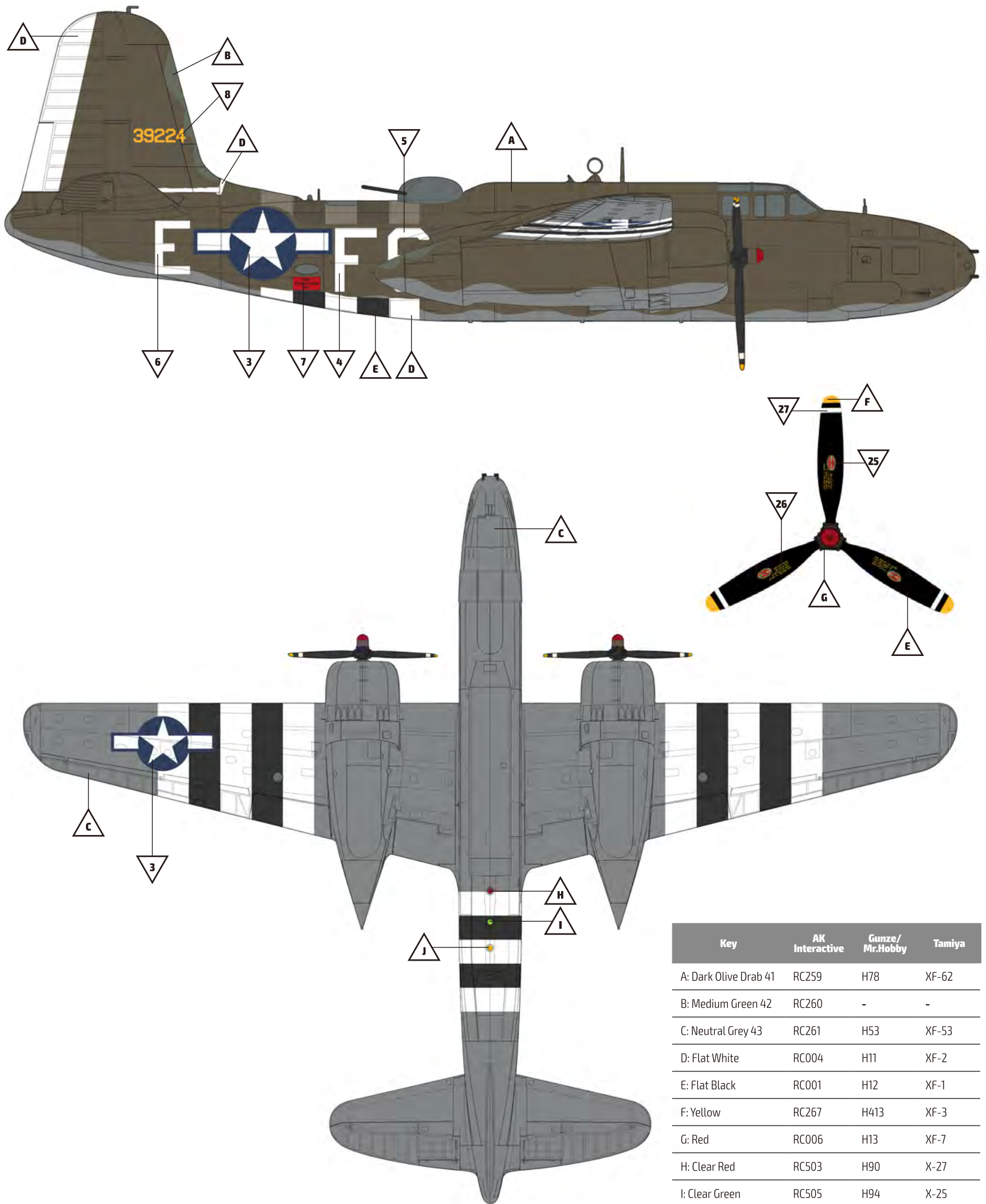

Key	AK Interactive	Gunze/Mr.Hobby	Tamiya
A: Dark Olive Drab 41	RC259	H78	XF-62
B: Medium Green 42	RC260	-	-
C: Neutral Grey 43	RC261	H53	XF-53
D: Flat White	RC004	H11	XF-2
E: Flat Black	RC001	H12	XF-1
F: Yellow	RC267	H413	XF-3
G: Red	RC006	H13	XF-7
H: Clear Red	RC503	H90	X-27
I: Clear Green	RC505	H94	X-25
J: Clear Orange	RC506	H92	X-26

MARKING

C

A-20G-25-DO, s/n 43-9224, 670th BS/416th BG, Paris, France, 4th November 1944

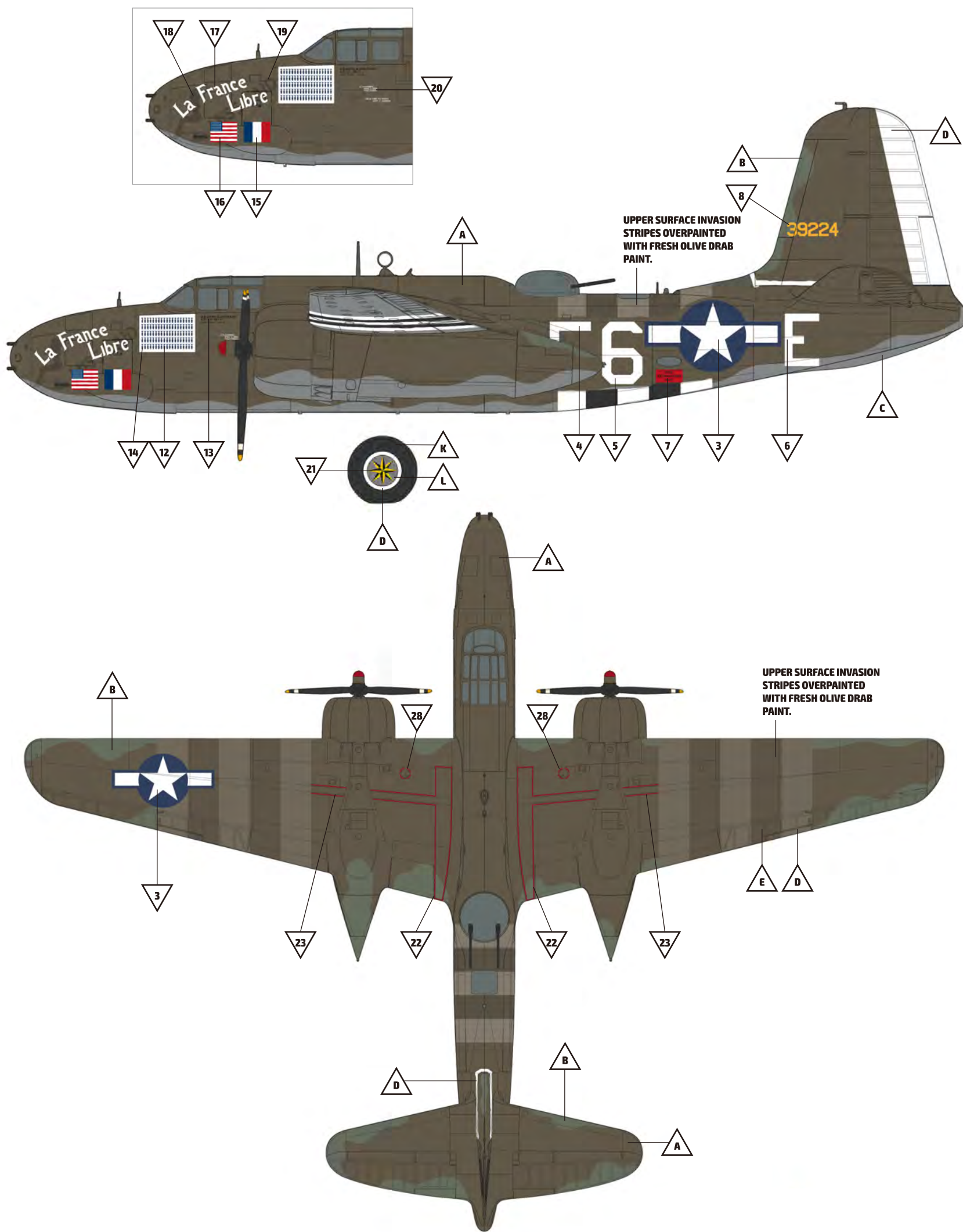



# MARKING

## C

### A-20G-25-DO, s/n 43-9224, 670th BS/416th BG, Paris, France, 4th November 1944

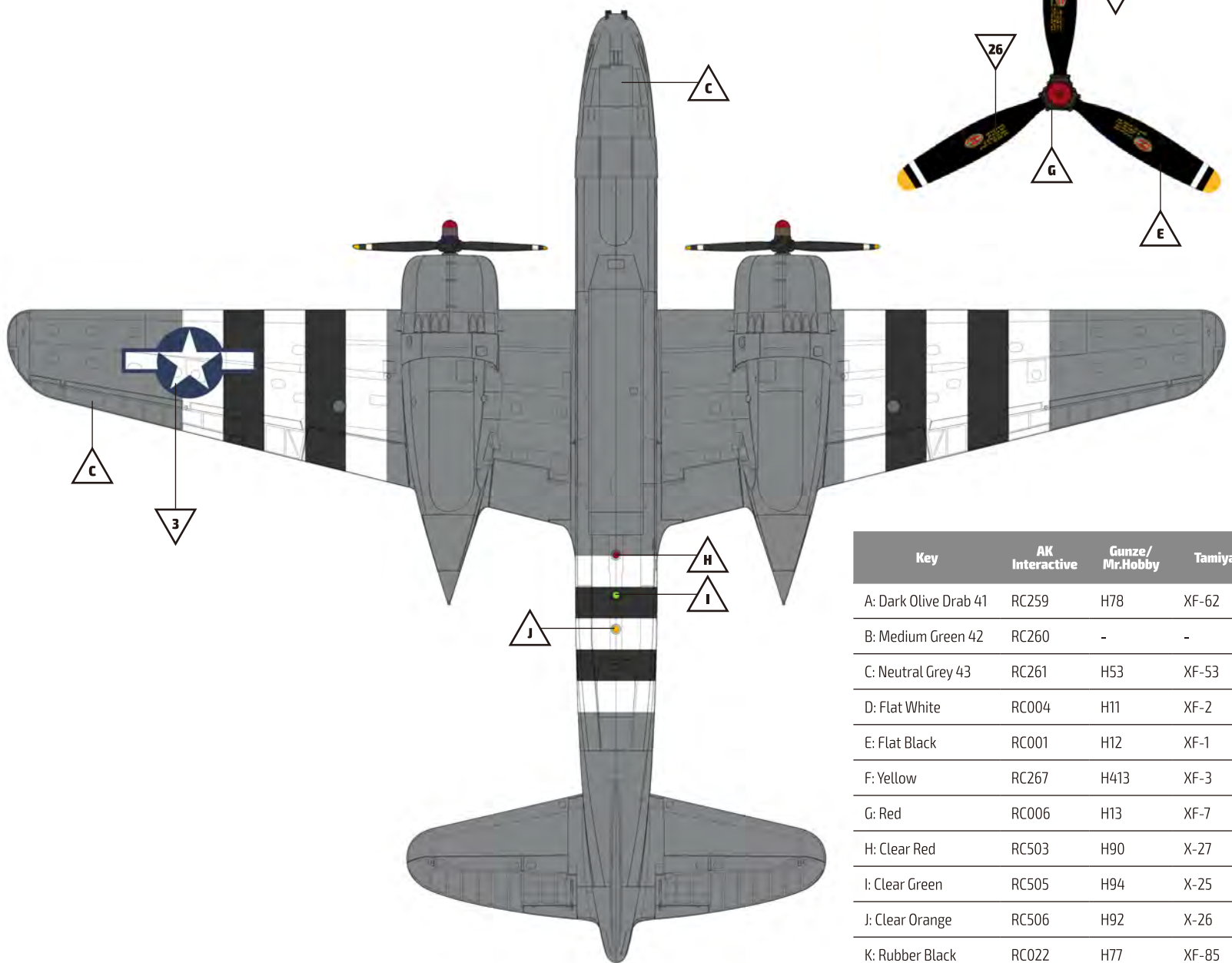
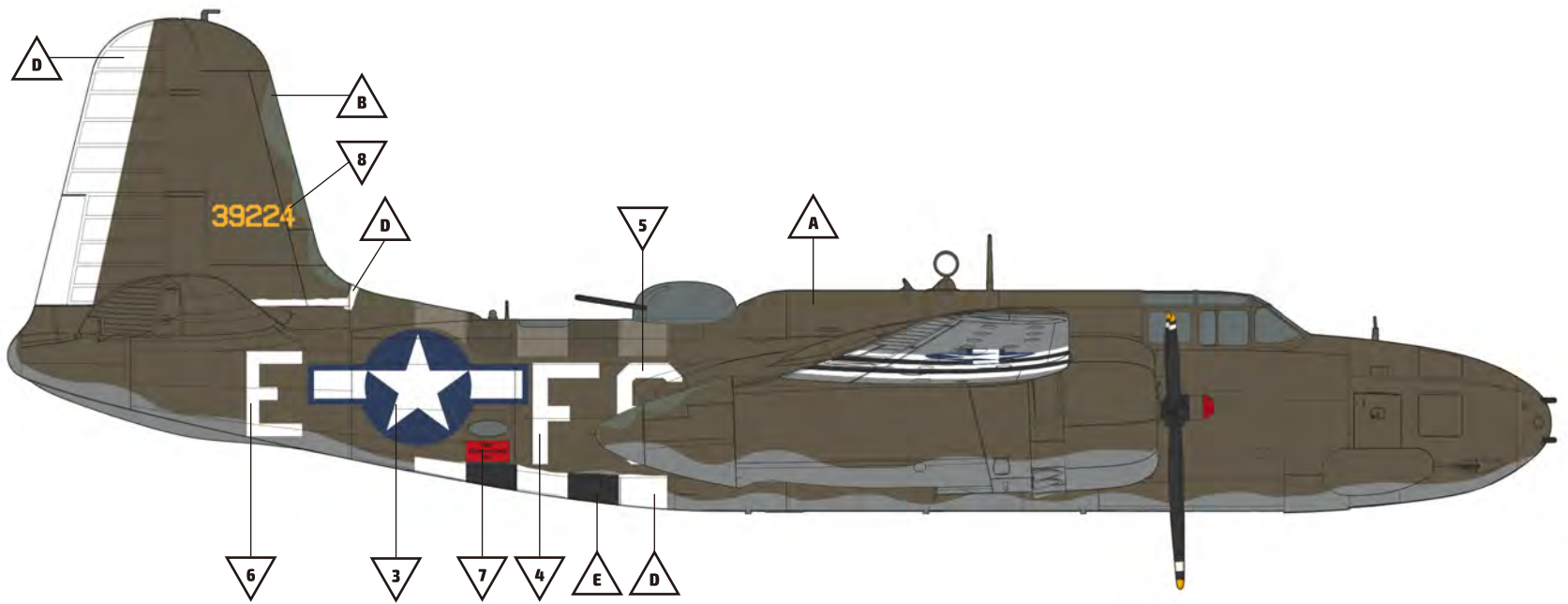

Key	AK Interactive	Gunze/Mr.Hobby	Tamiya
A: Dark Olive Drab 41	RC259	H78	XF-62
B: Medium Green 42	RC260	-	-
C: Neutral Grey 43	RC261	H53	XF-53
D: Flat White	RC004	H11	XF-2
E: Flat Black	RC001	H12	XF-1
F: Yellow	RC267	H413	XF-3
G: Red	RC006	H13	XF-7
H: Clear Red	RC503	H90	X-27
I: Clear Green	RC505	H94	X-25
J: Clear Orange	RC506	H92	X-26
K: Rubber Black	RC022	H77	XF-85
L: Aluminium	RC020	H8	XF-16

## Colour Guide

Key	AK Interactive	Gunze/Mr.Hobby	Tamiya
A: Dark Olive Drab 41	RC259	H78	XF-62
B: Medium Green 42	RC260	—	—
C: Neutral Grey 43	RC260	H53	XF-53
D: Flat White	RC004	H11	XF-2
E: Flat Black	RC001	H12	XF-1
F: Yellow	RC267	H413	XF-3
G: Red	RC006	H13	XF-7
H: Clear Red	RC503	H90	XF-27
I: Clear Green	RC505	H94	XF-25
J: Clear Orange	RC506	H92	XF-26
K: Rubber Black	RC022	H77	XF-85
L: Silver	RC020	H8	XF-16
M: Yellow-Green (Tinted Zinc Chromate)	RC262	—	XF-4:5+XF-1:1
N: Tan	RC019	H85	XF-55
O: Gunmetal	RC015	MC214	X-10
P: Engine Grey	RC296	H331	XF-77
Q: Steel	AK476	H18	XF-56
R: Burnt Metal	AK485	H76	87085
S: Plywood	RC014	H79	XF-78
T: Leather	RC11110	H47	XF-64

In cooperation with:



Illustration, manual layout and format: **HK Models & AK-Interactive**  
 Manual and assistance: **AK-Interactive**  
 Introductory text: **Cees Broere**

