

1:32 SCALE

ITEM NO.:03201

F-14A Tomcat

F-14A "雄猫"战斗机



READ BEFORE ASSEMBLY:

- Study and understand these instructions thoroughly before beginning assembly
- When needed, remove photo-etch parts carefully using a modeling knife or photo etch sprue cutter, being careful not to damage or lose small parts.
- Take extra care in handling photo etch parts in order to avoid injury
- Apply instant cement sparingly to photo etch parts where instructed

- Tools recommended(not included in kit):Plastic and instant cements,sprue cutters,long nose pliers,modeling knife, small files, tweezers, pin vise & scissors. Soft cloth and sandpaper will also assist in construction
- Glue and paint are not included in the kit. Use plastic cement and hobby paints only. Color guide for purchasing paint is included in the kit.

装配之前仔细阅读

- 小心用模型锉刀锉平所有零件表面的注射浇口。
- 小心用刀片切下蚀刻片零件，不要遗失小零件。
- 用强力快干胶水粘合蚀刻片零件和金属轴。过量快干胶水，使用可能导致可动零件会粘住，小心涂胶。
- 取蚀刻片时应特别注意安全，防止利边划伤手指。
- 某些零件表面需贴水上贴纸，请选择在装配的同时进行。
- 推荐模型工具(自备)：胶水，水口剪刀，长咀钳，刀片，锉刀，镊子，钳，钻，剪刀，瞬间快干胶。
- 软布同砂纸同时也应该是必备工具。
- 请使用塑料胶水和油漆，模型内不含。

水贴纸的使用:

1. 从水贴上剪下印花;
2. 将印花放入温水中浸10秒, 然后放在干净布上.
3. 拿着印花纸板将印花移到模型上;
4. 手指蘸水将印花移到适当的位置;
5. 用软布轻压印花直至水干, 汽泡消失.

DECAL APPLICATION.

1. Cut decals from sheet as needed
2. Dip the decal in warm water for about 10 seconds and then place on soft clean cloth.
- 3 Hold the decal backing sheet edge and gently slide the decal onto the model in its proper position

- 4 While still wet,decal can be adjusted for better fit on model by dampening it gently with your finger.
5. When placed in the proper position,gently press decal down with a soft cloth until excess water and air bubbles are gone.
6. Allow decal to dry completely before handling model



cyanoacrylate glue
使用强力胶



weight
配重



make hole
钻孔



cut / remove
切除



option
选择



no cement
不涂胶水



decal
贴纸



bend
弯曲



file / sand
锉平

1

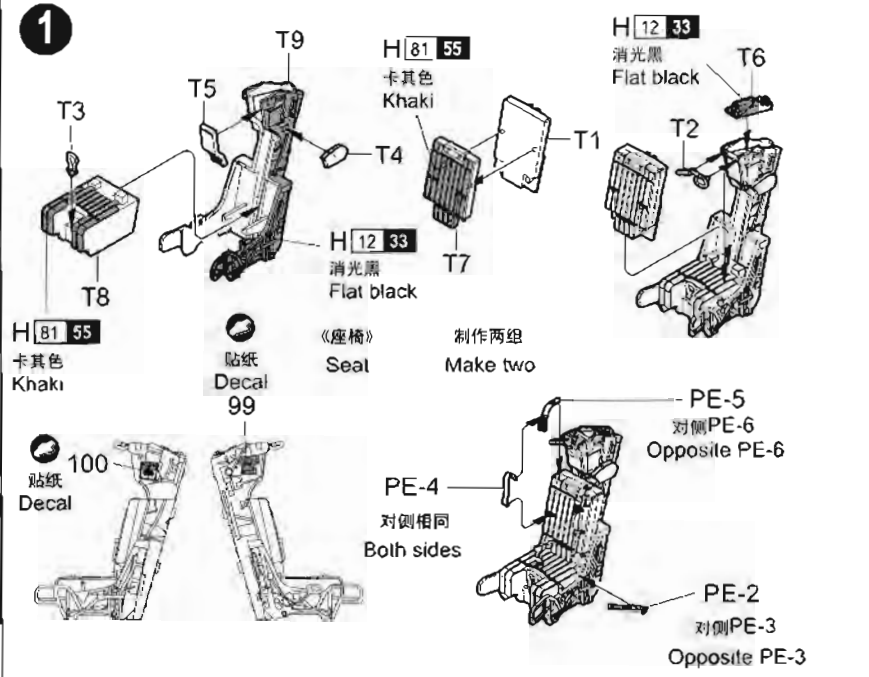

2

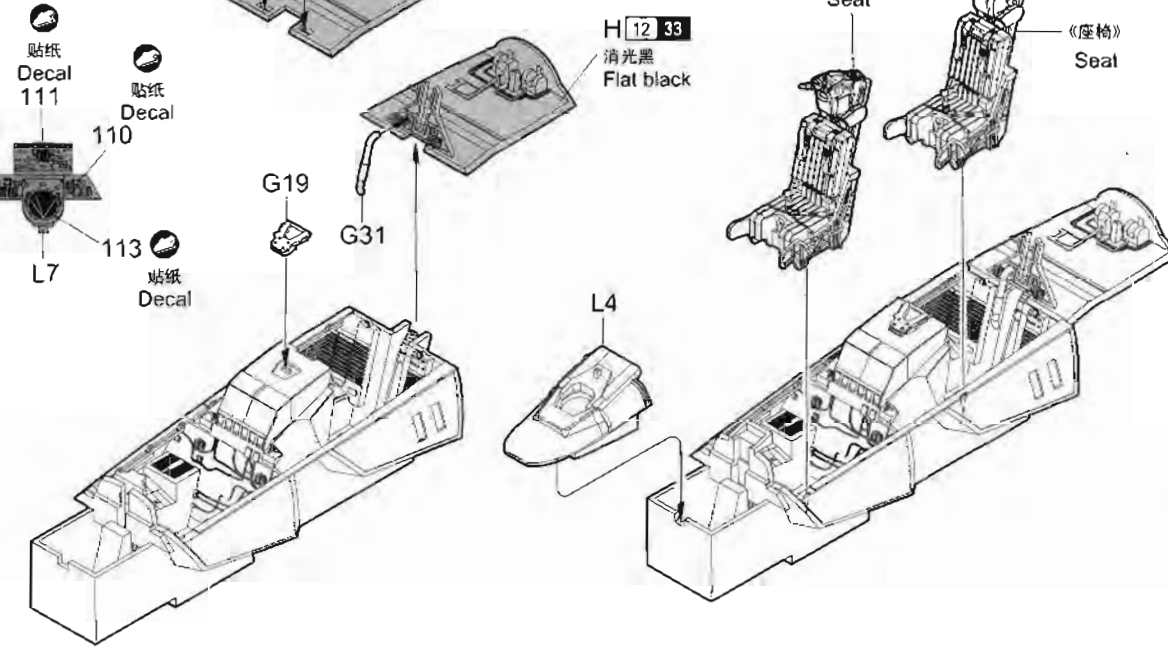
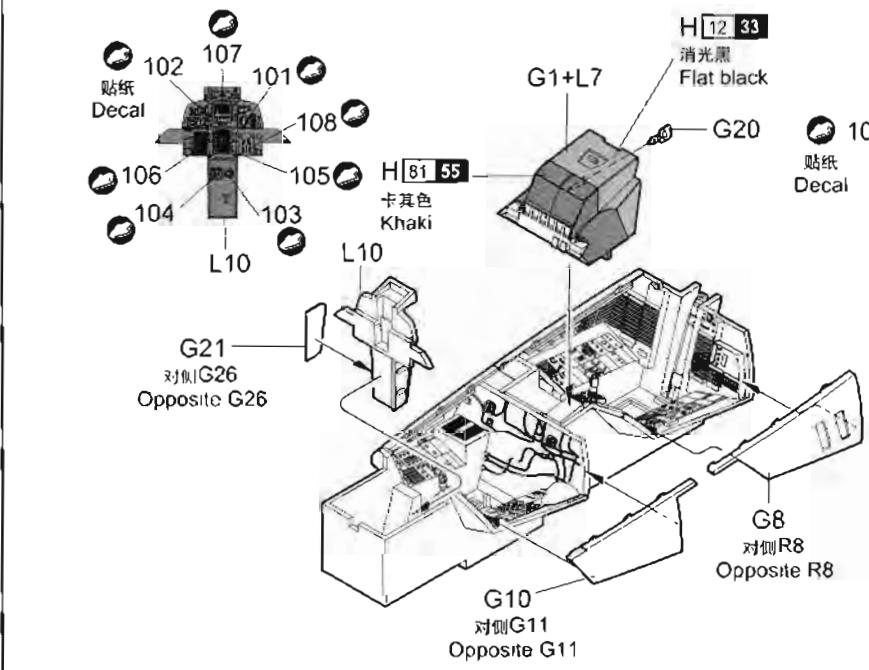
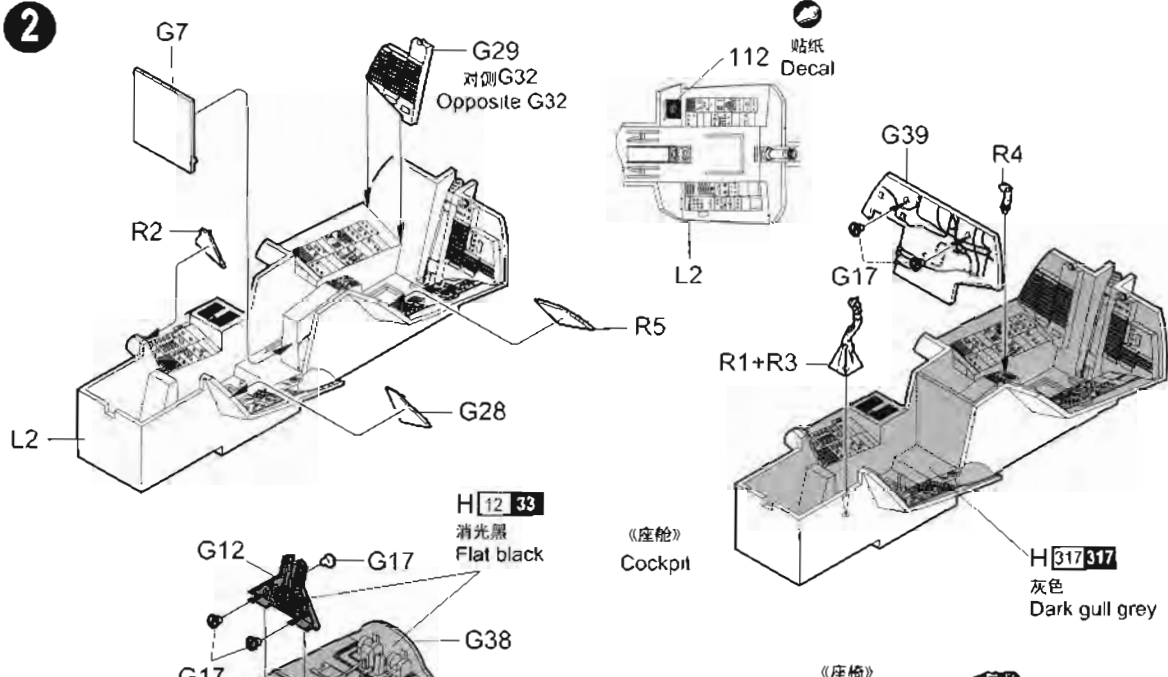

3

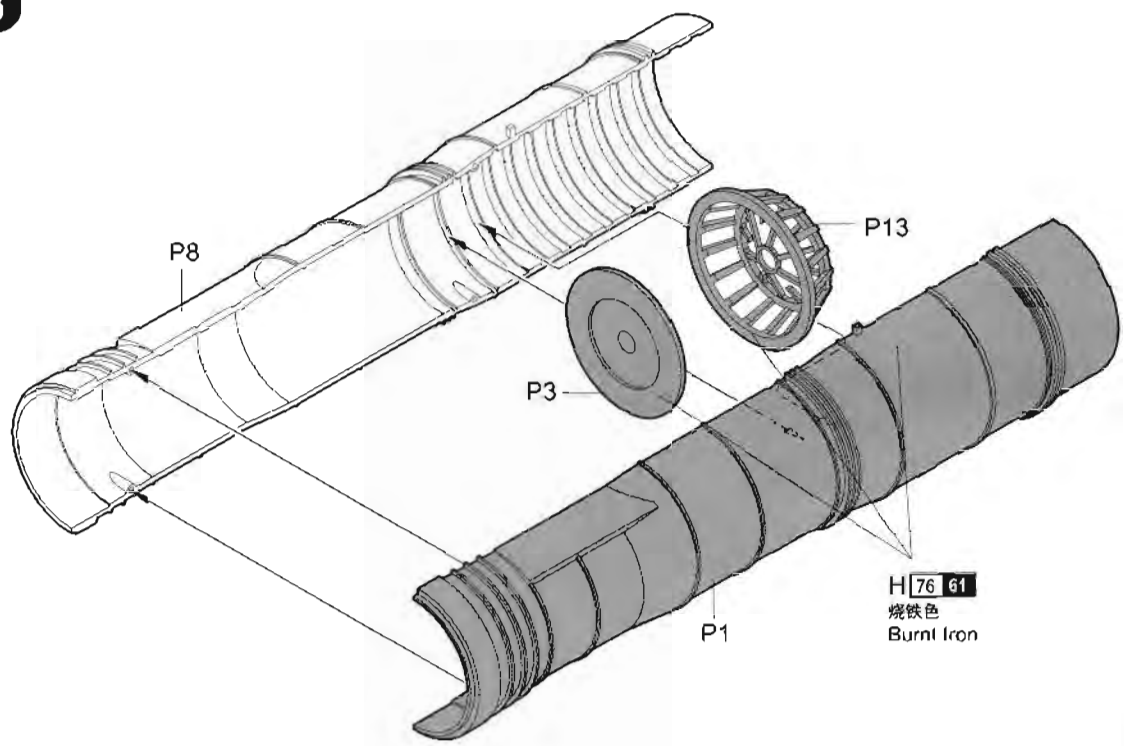

《发动机》
Engine

制作两组
Make two

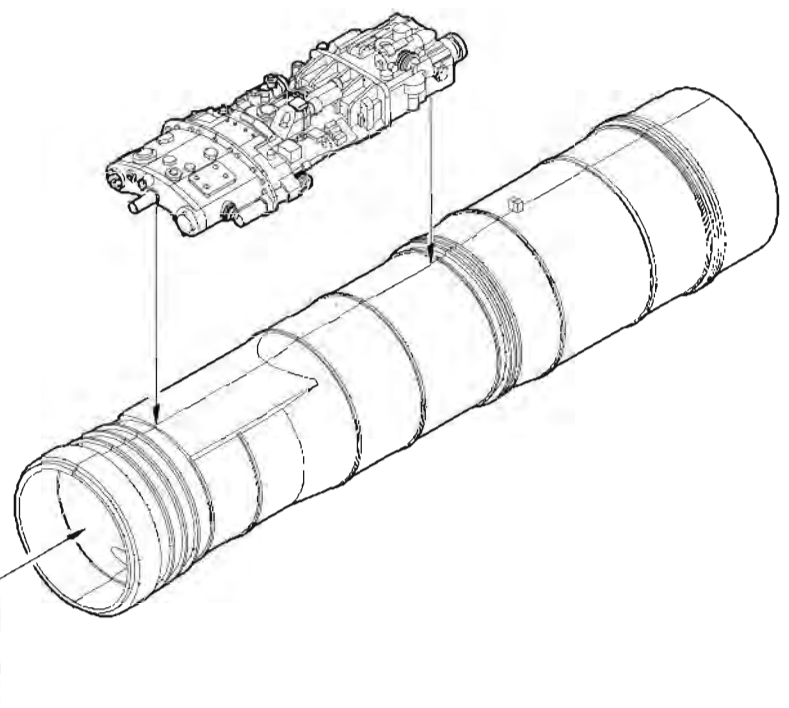
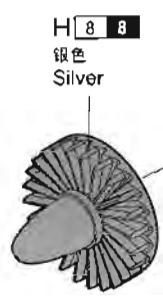
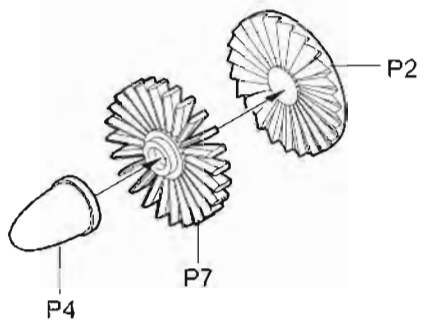
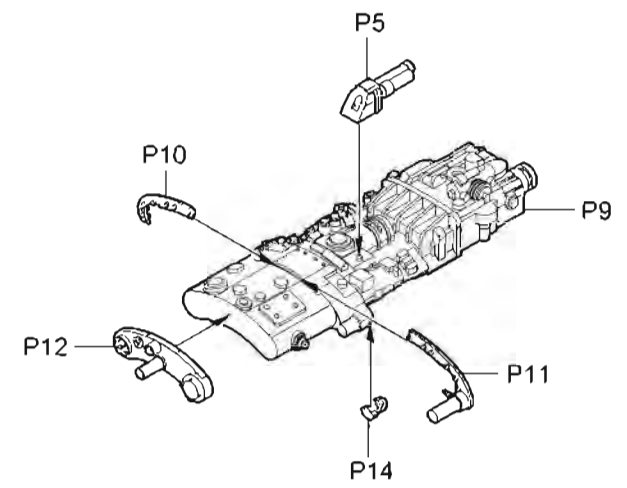

4

《前起落架》
Nose undercarriage

《前轮胎》
Nose tyre

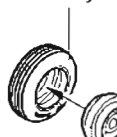

制作两组
Make two

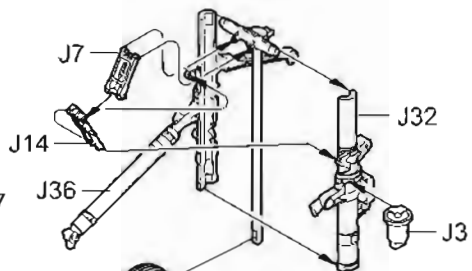

《前合金起落架(长)》
Nose alloy undercarriage (Long)

H 316 316
白色
White Insignia

对侧相同
Both sides

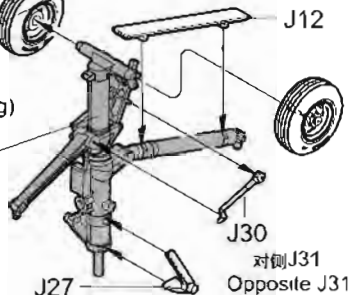

2
选择
Option

《前起落架》
Nose undercarriage

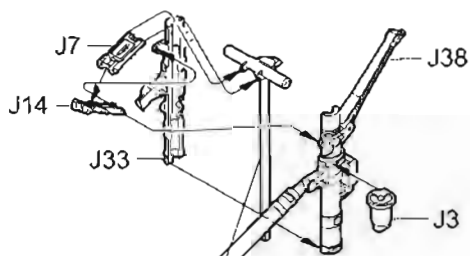

《前合金起落架(短)》
Nose alloy undercarriage (Short)

H 316 316
白色
White Insignia

对侧相同
Both sides

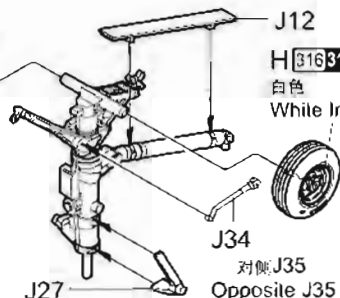

5

《雷达》
Radar

PE-1X12

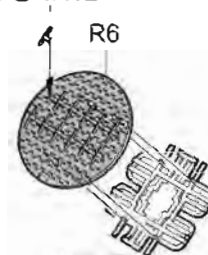

H 329 329
黄色
Orange Yellow

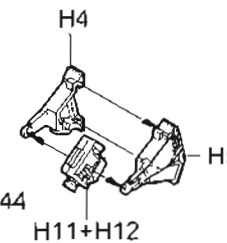

H 334 334
麦灰色
Barley grey BS4800/18B21

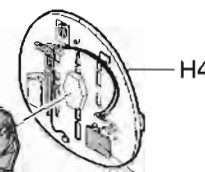

H 316 316
白色
White Insignia

6

《主轮》
Main wheel

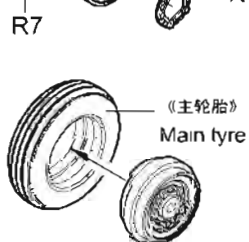
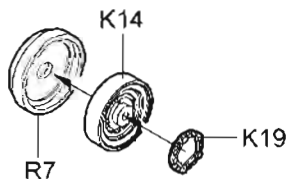

制作两组
Make two

7

《左侧主起落架》
Left undercarriage

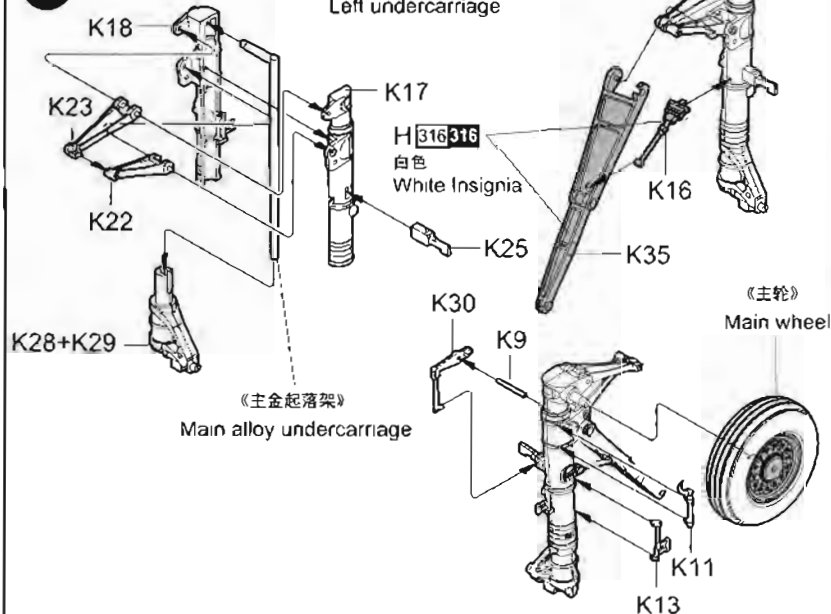

H 316 316
白色
White Insignia

《主轮》
Main wheel

8

《右侧主起落架》
Right undercarriage

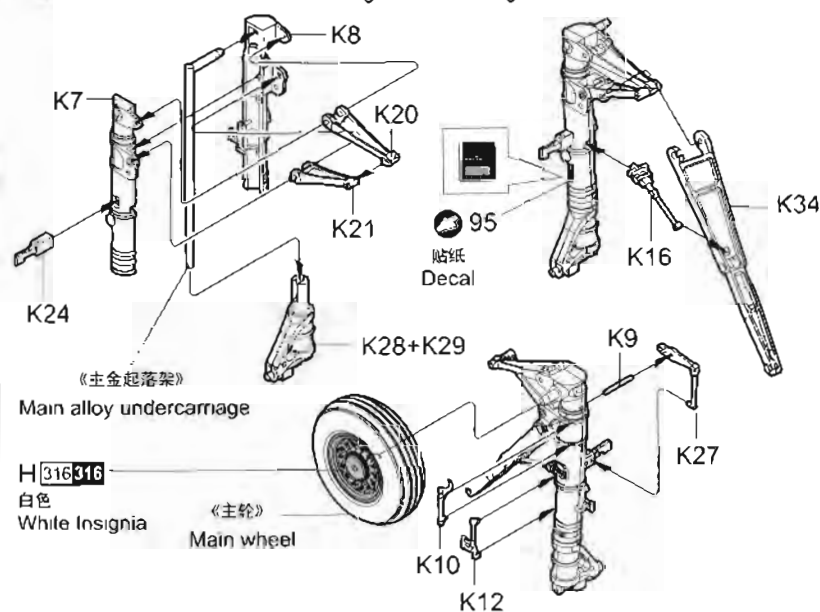

95
贴纸
Decal

H 316 316
白色
White Insignia

《主轮》
Main wheel

9

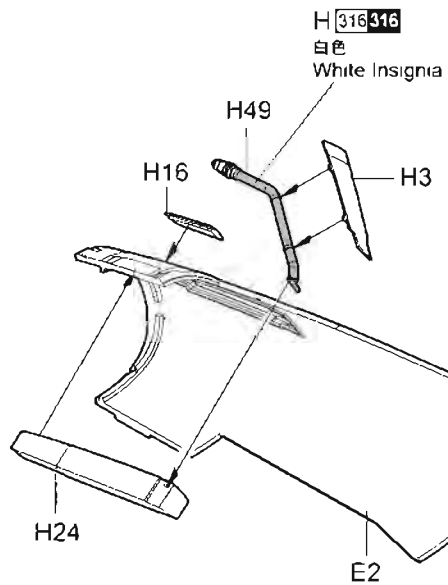

10

《前轮舱》
Nose gear cabin

《前起落架》
Nose undercarriage
仅在打开状态时使用
Use only when open

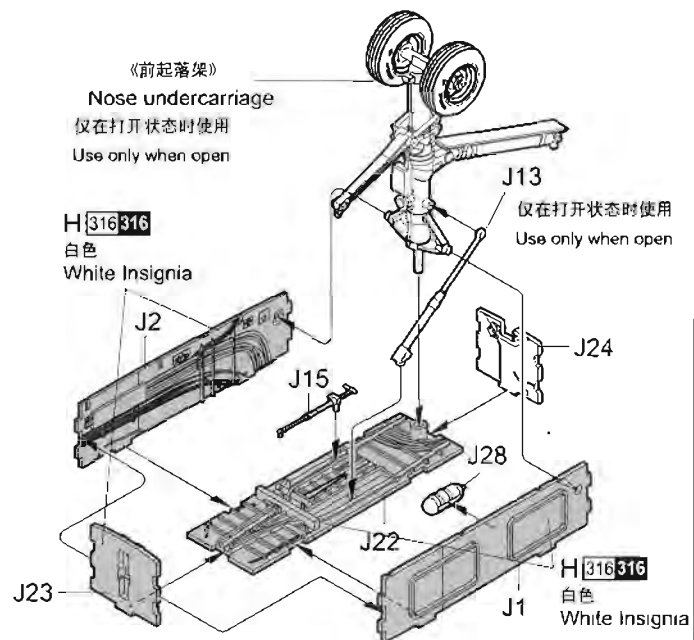

11

H 317 317
灰色
Dark gull grey

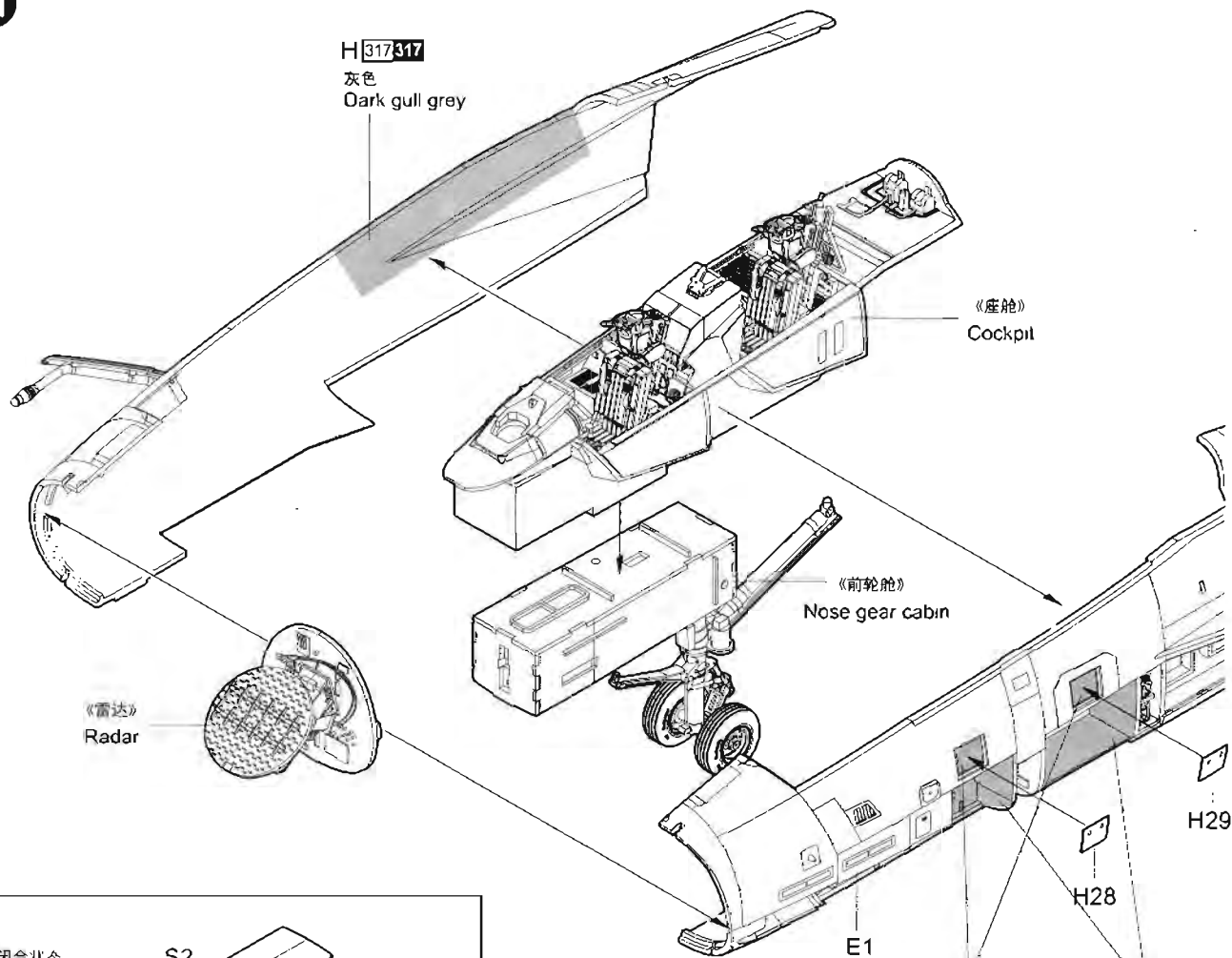

闭合状态
Close

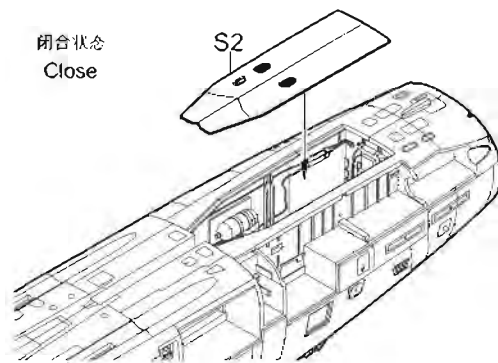

12

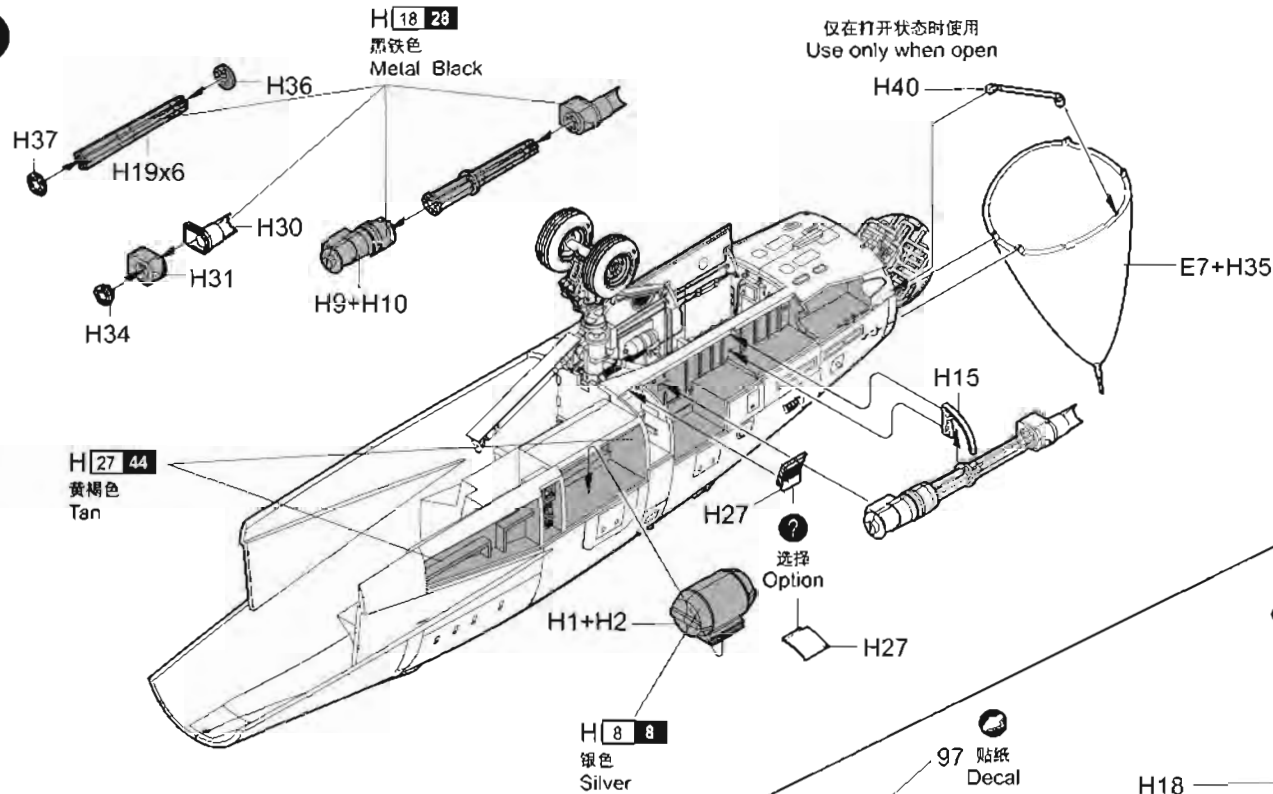

13

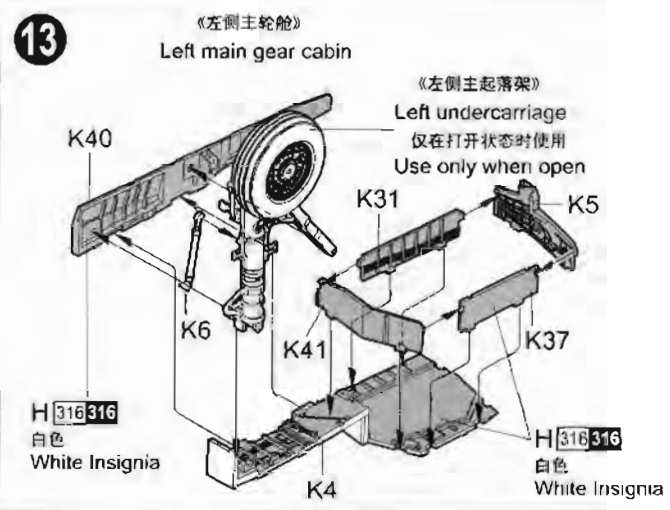

14

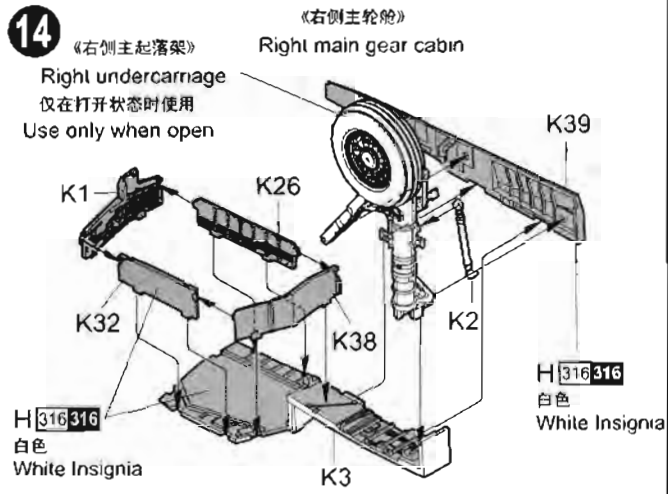

15

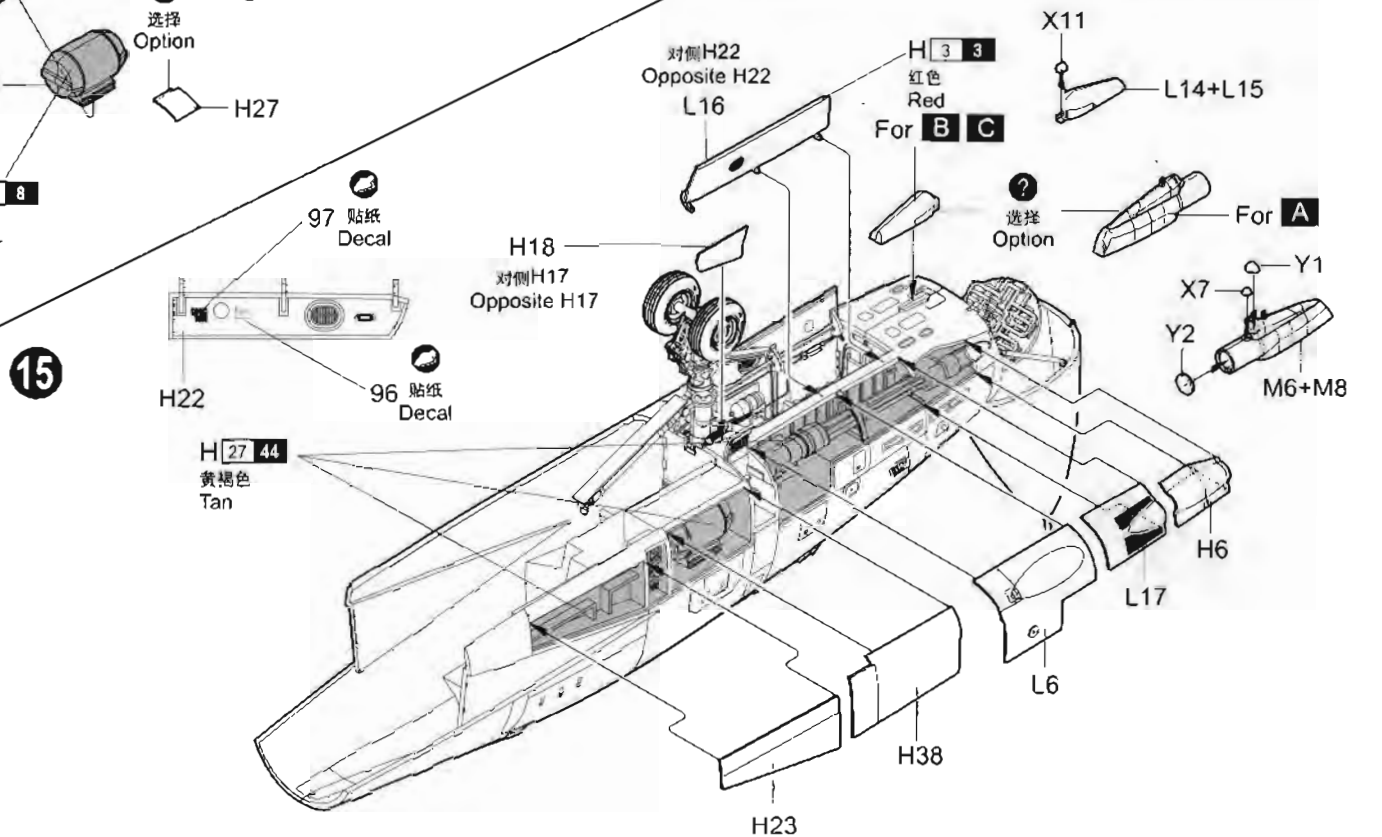

16

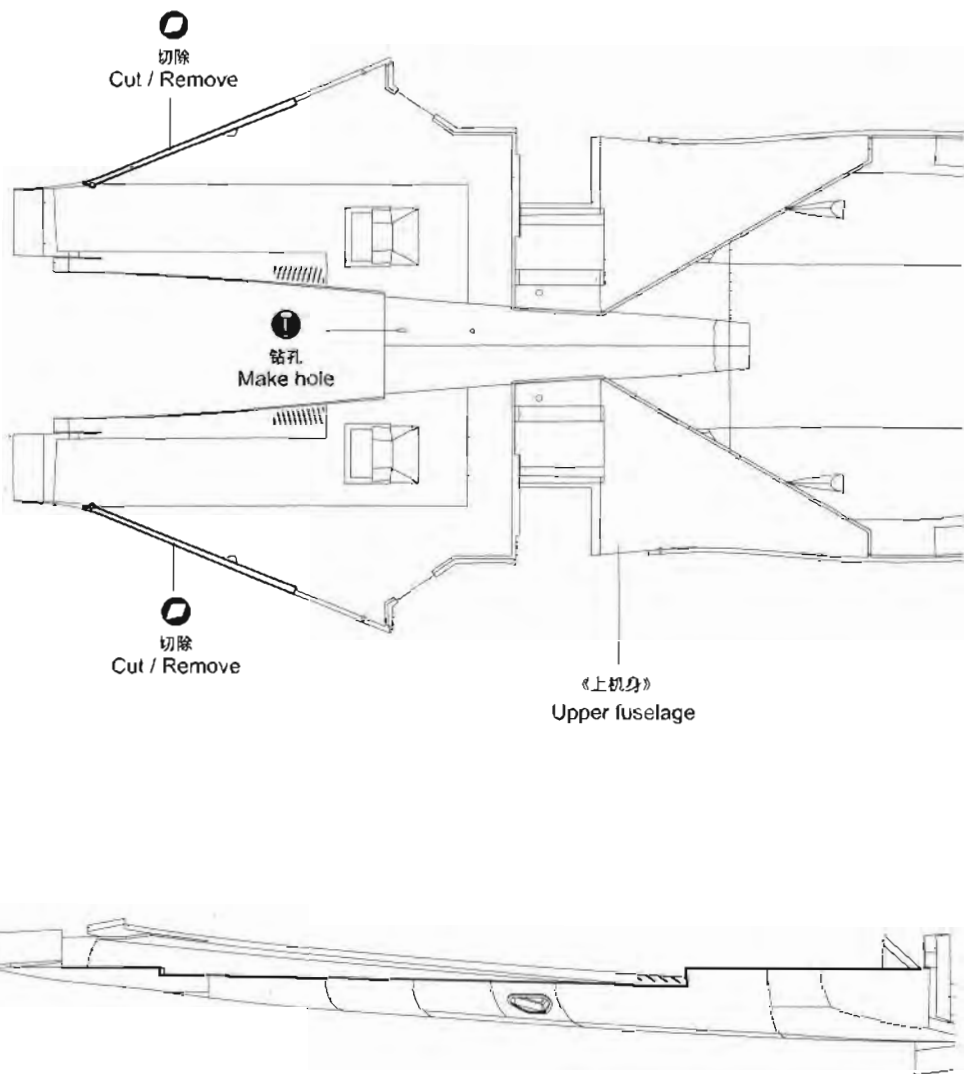

17

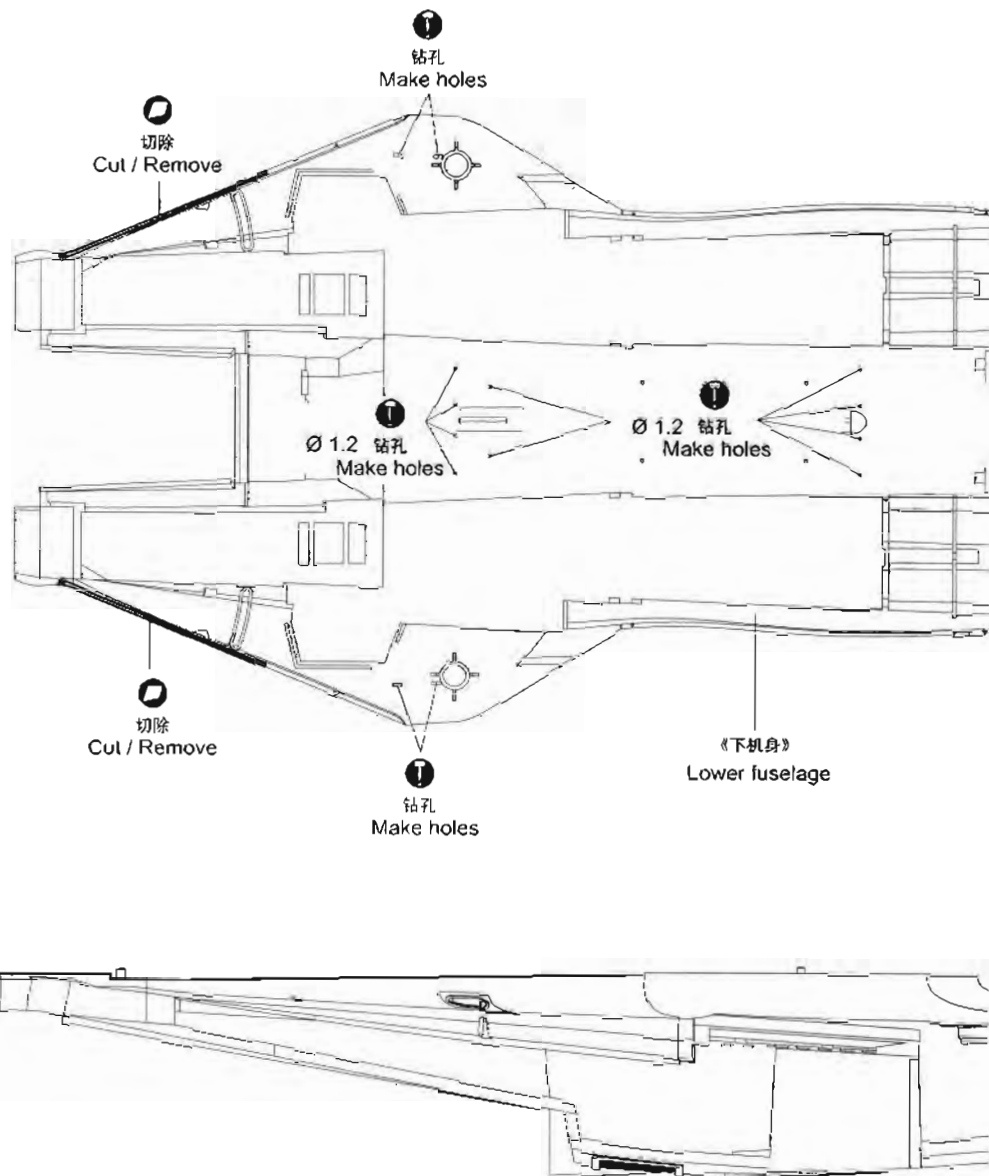

18

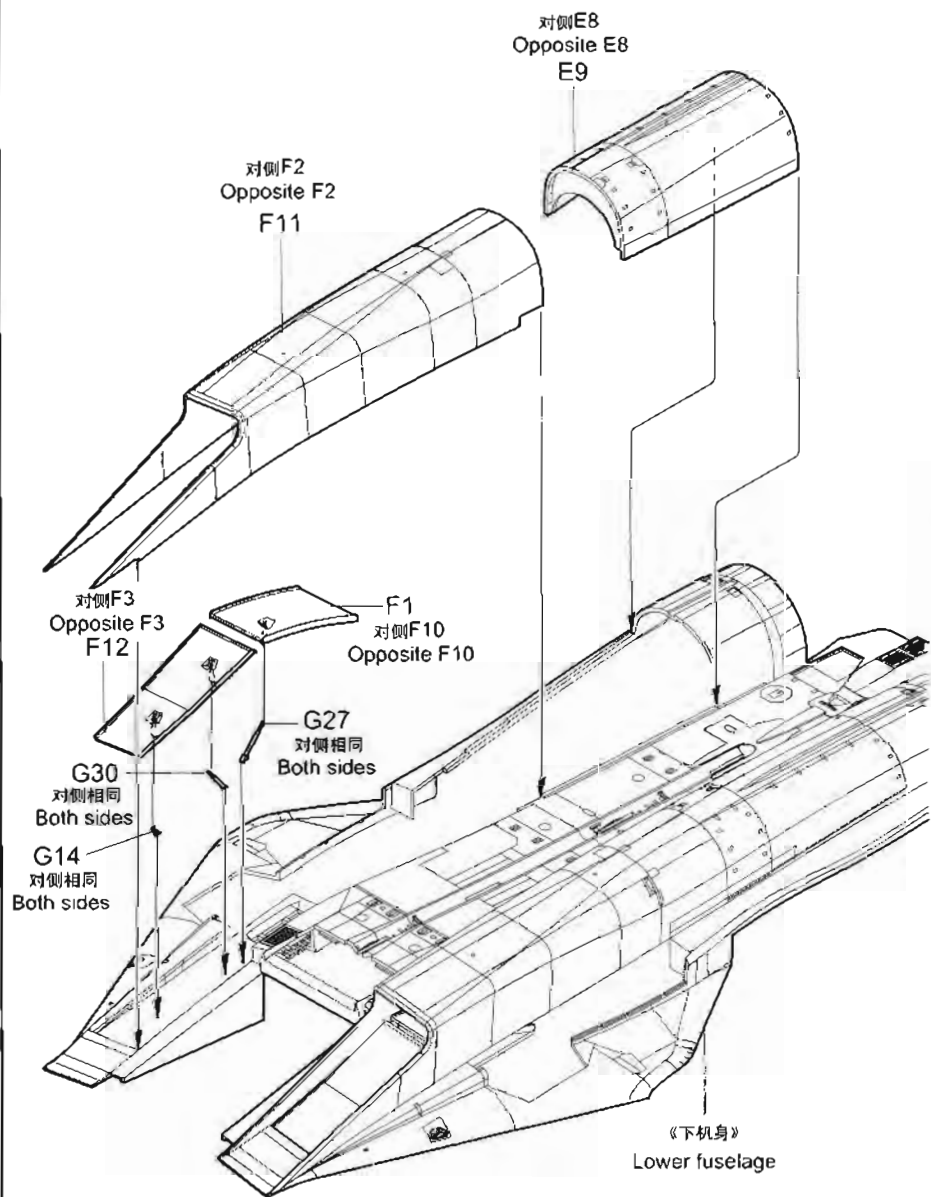

19

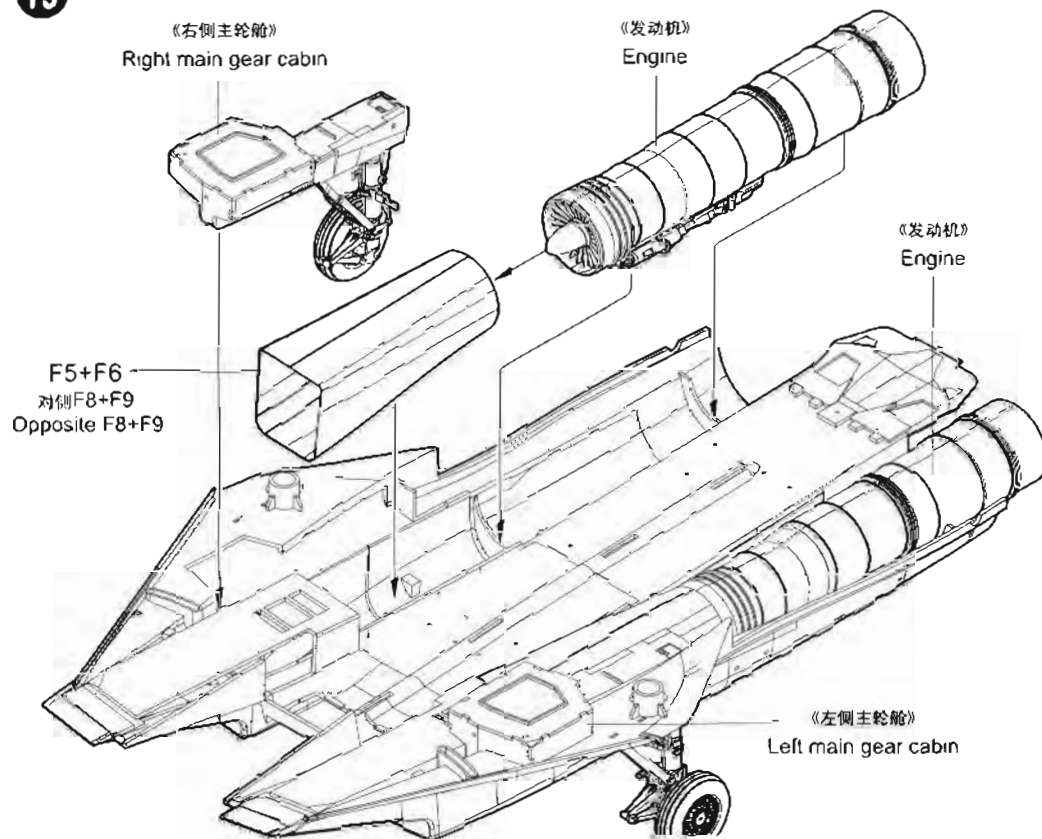

20

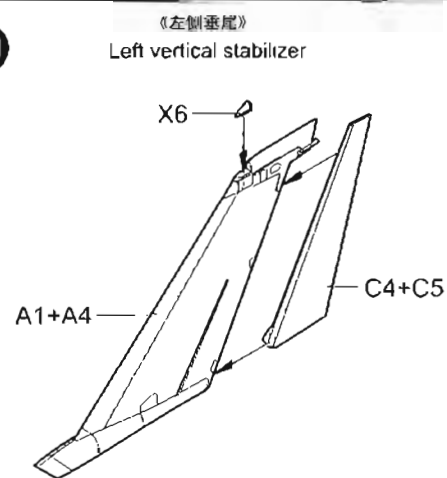

21

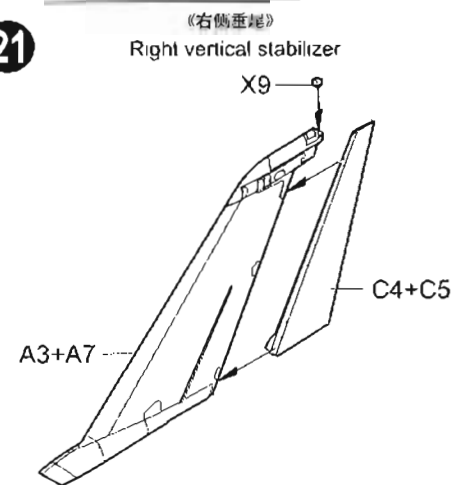

22

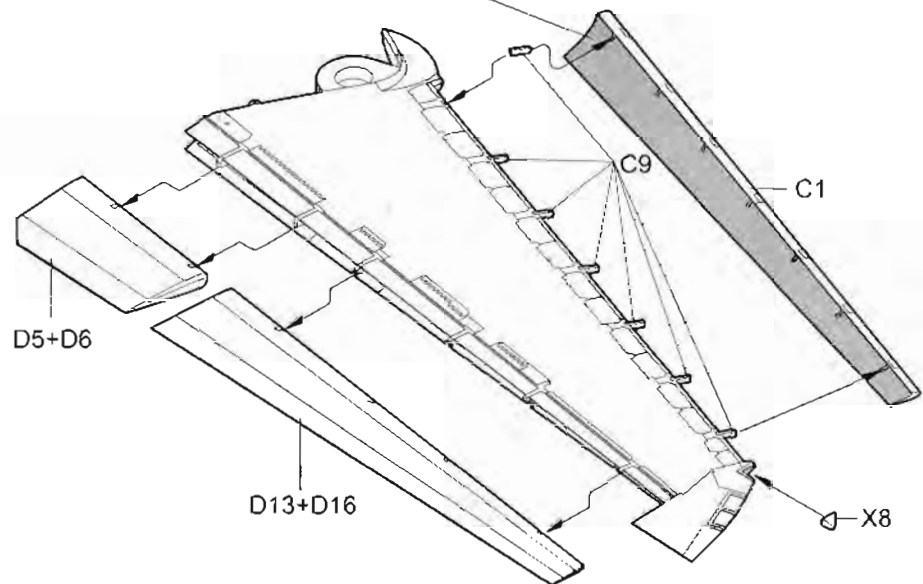
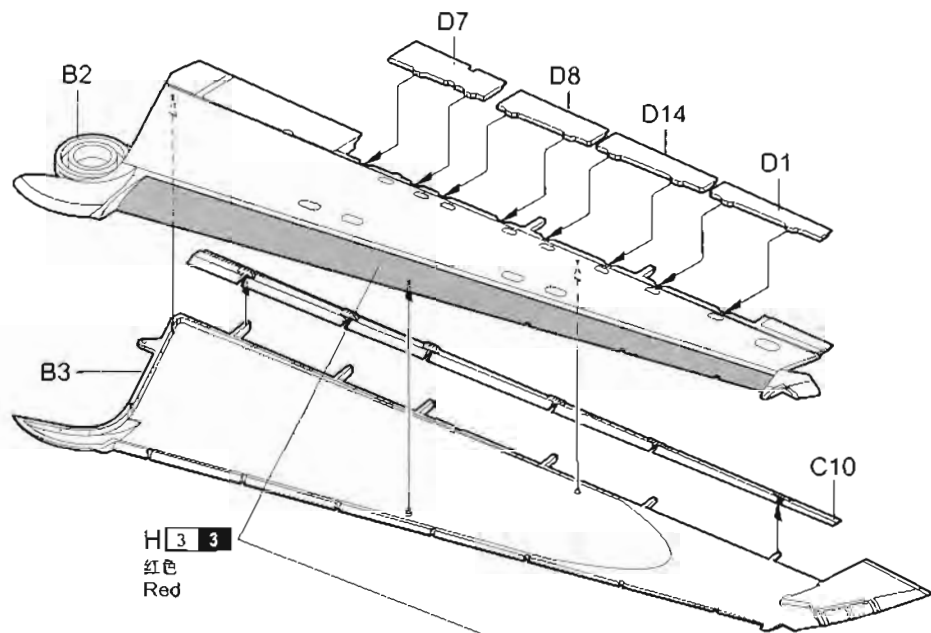
《左侧机翼》
Left wing

23

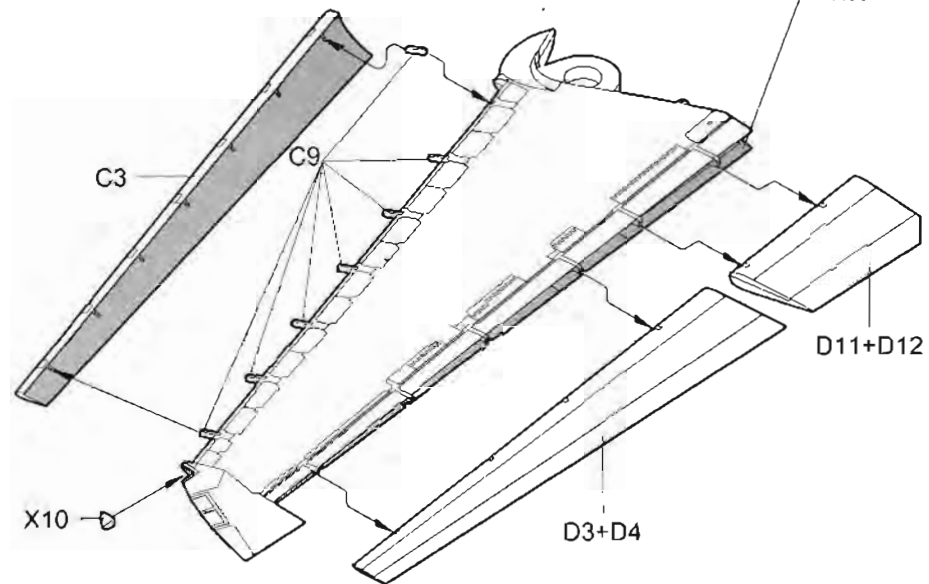
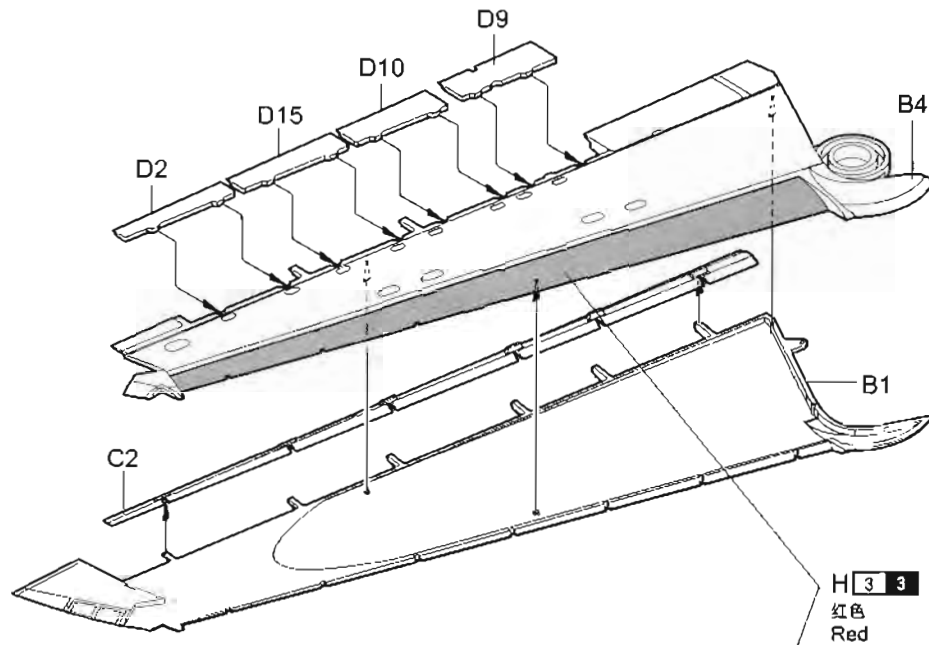
《右侧机翼》
Right wing

24

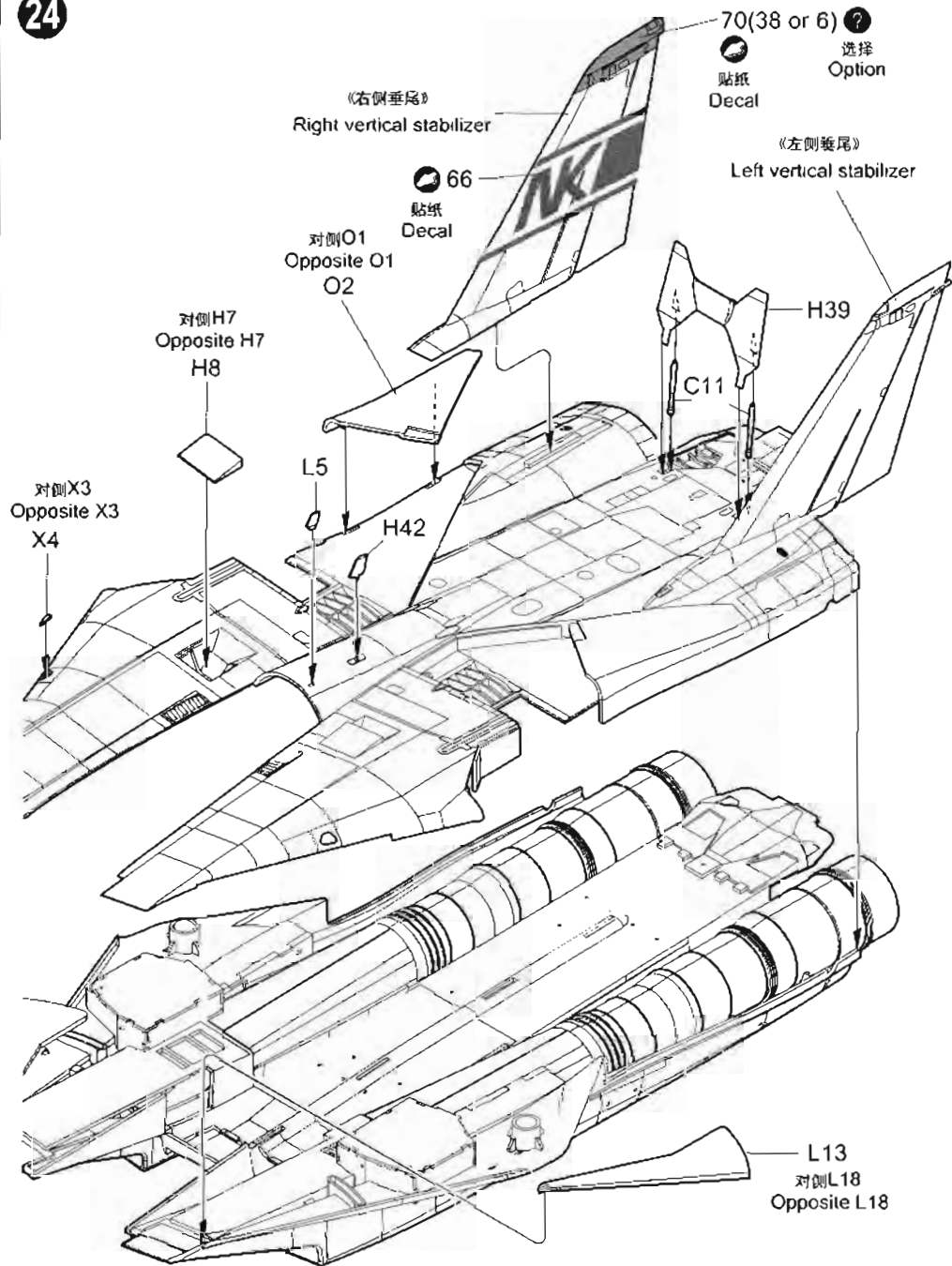

25

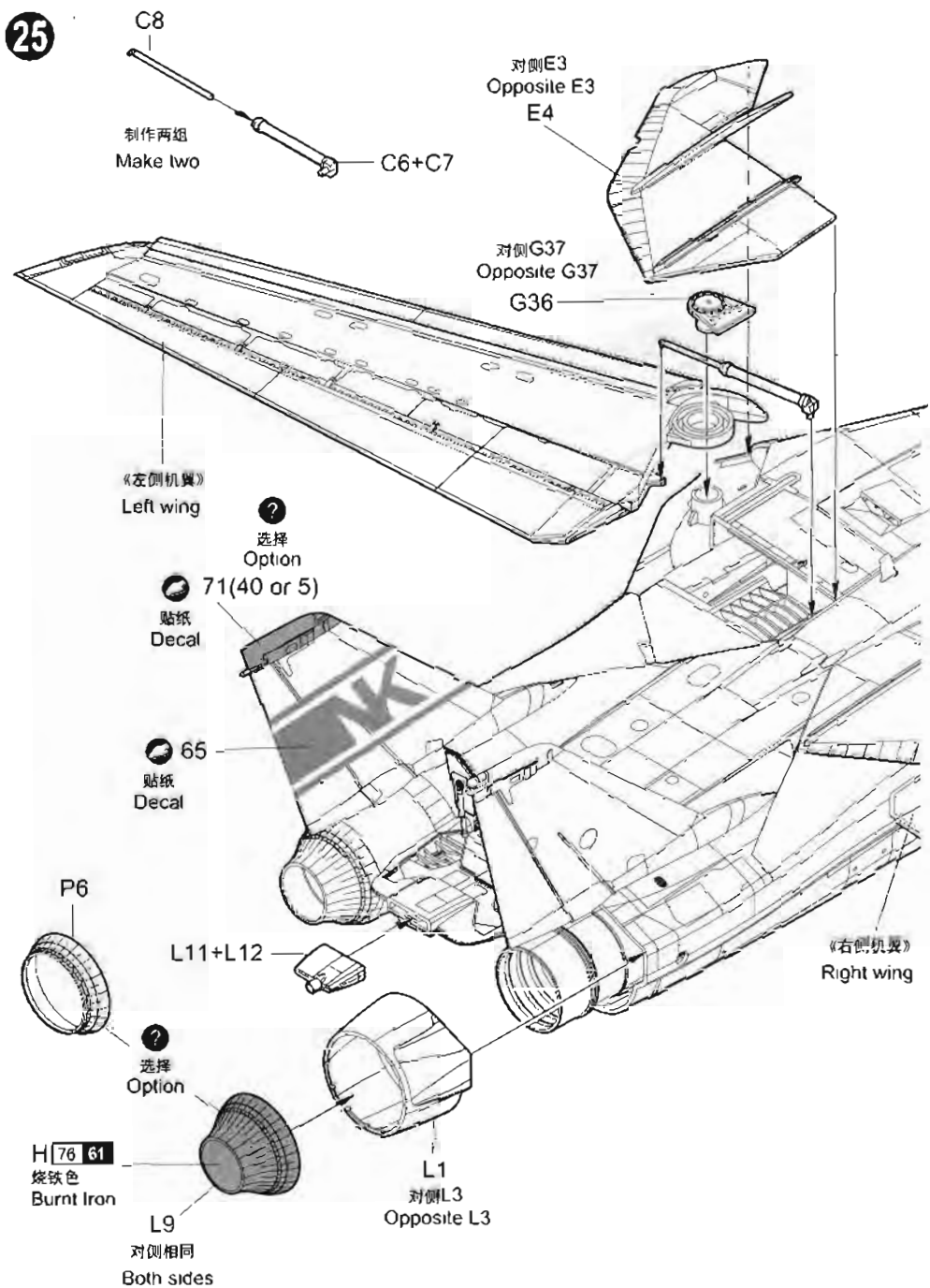

26

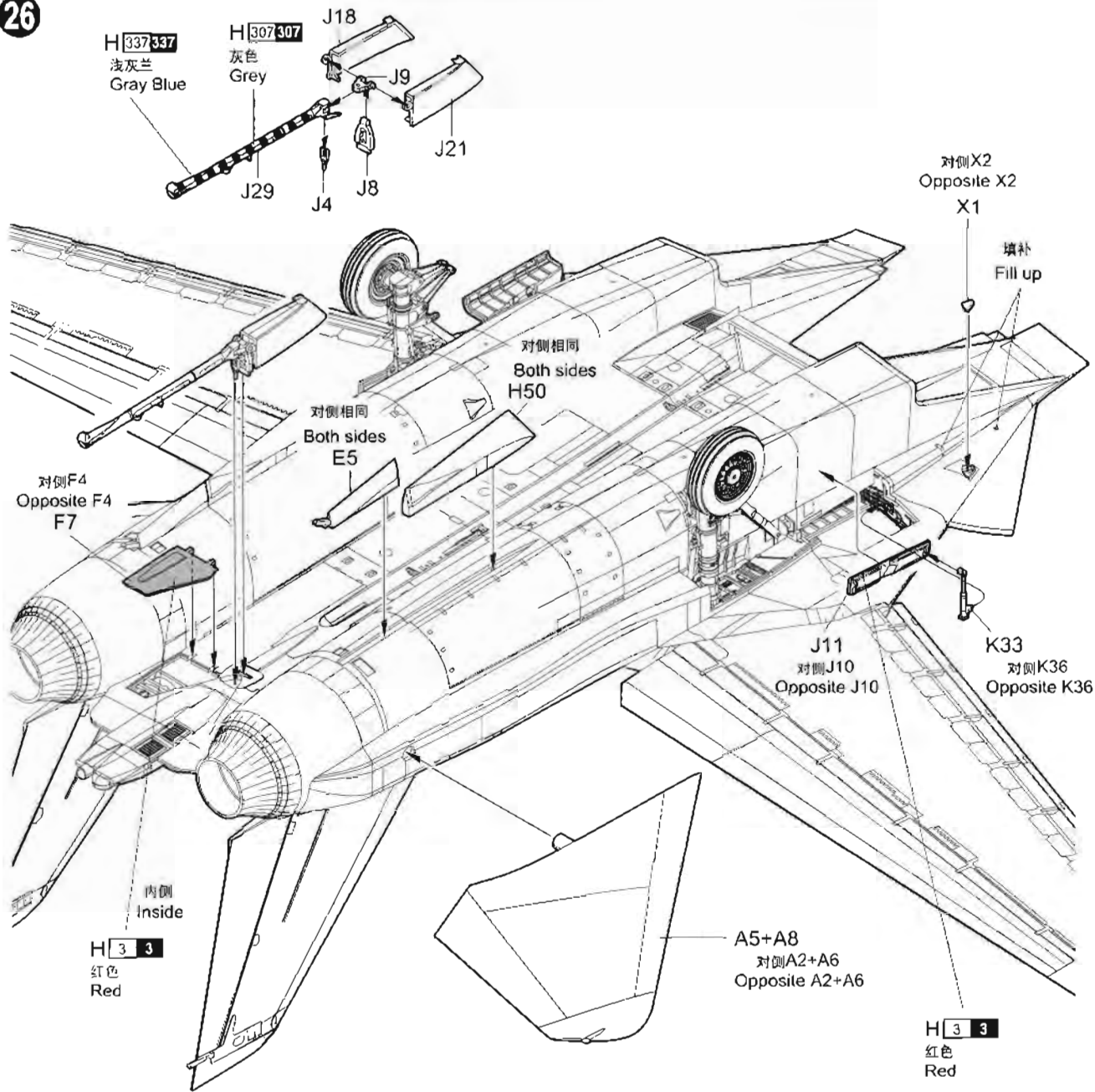

27

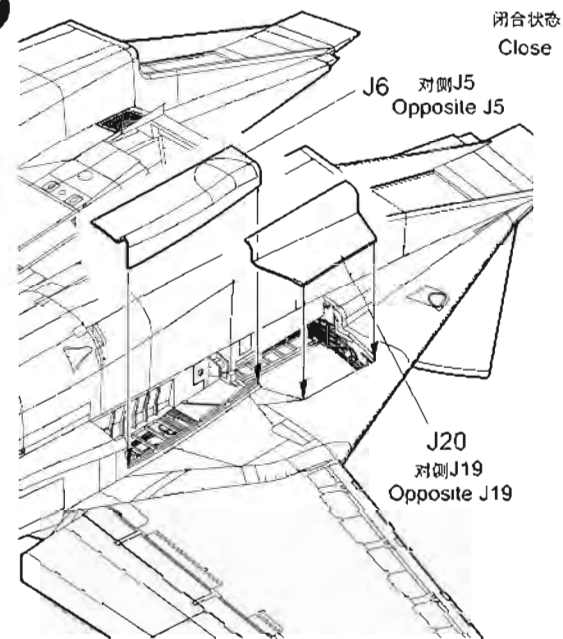

28

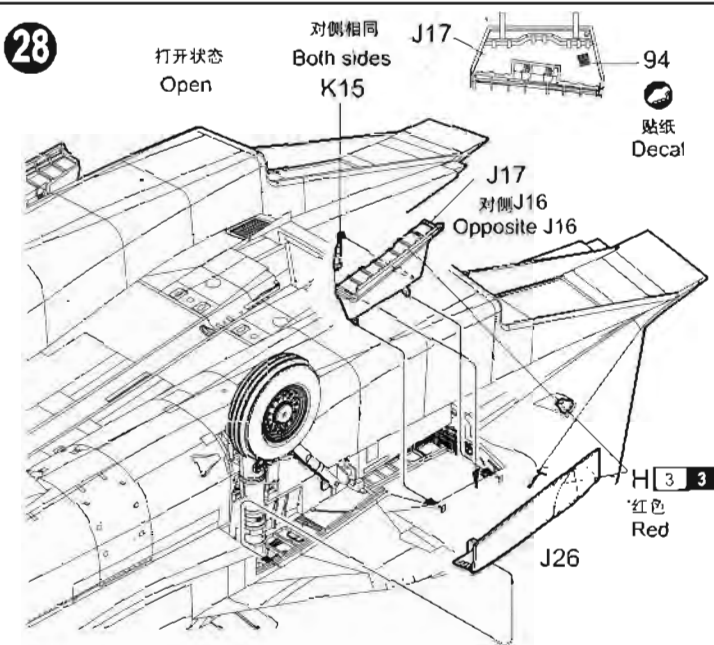

29

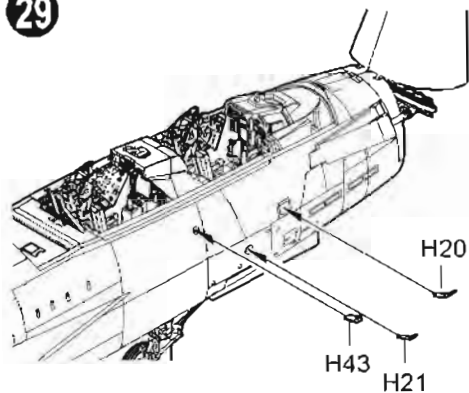

30

打开状态时装配
Assembly only when open

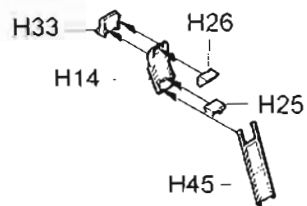

32

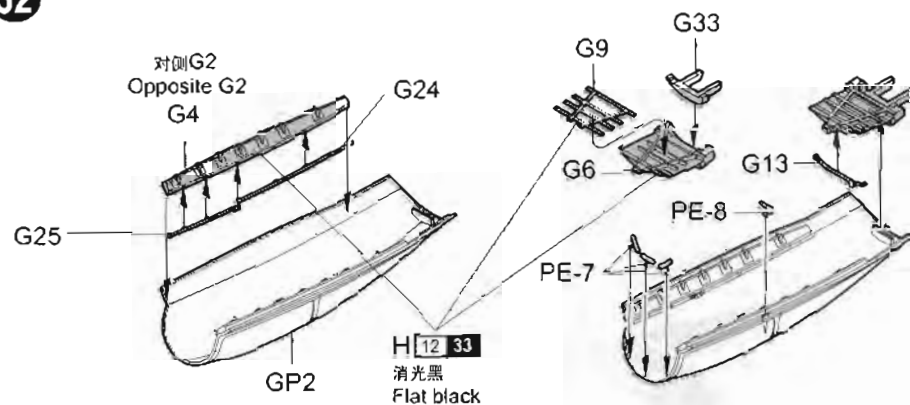

31

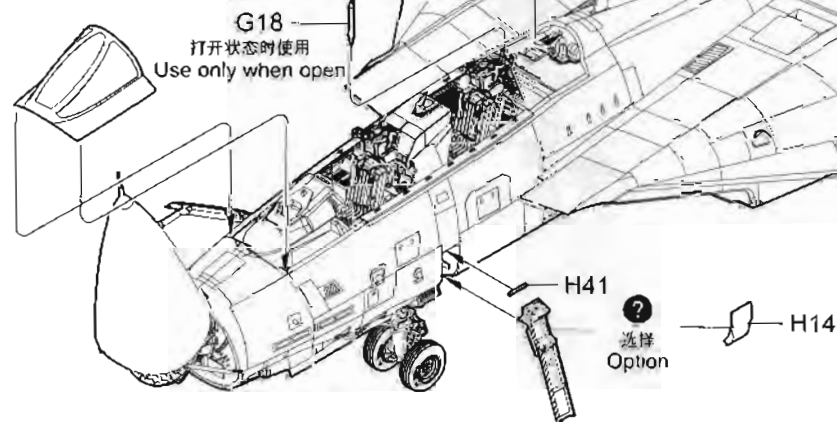
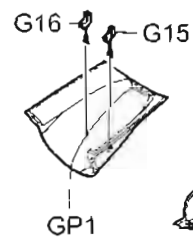
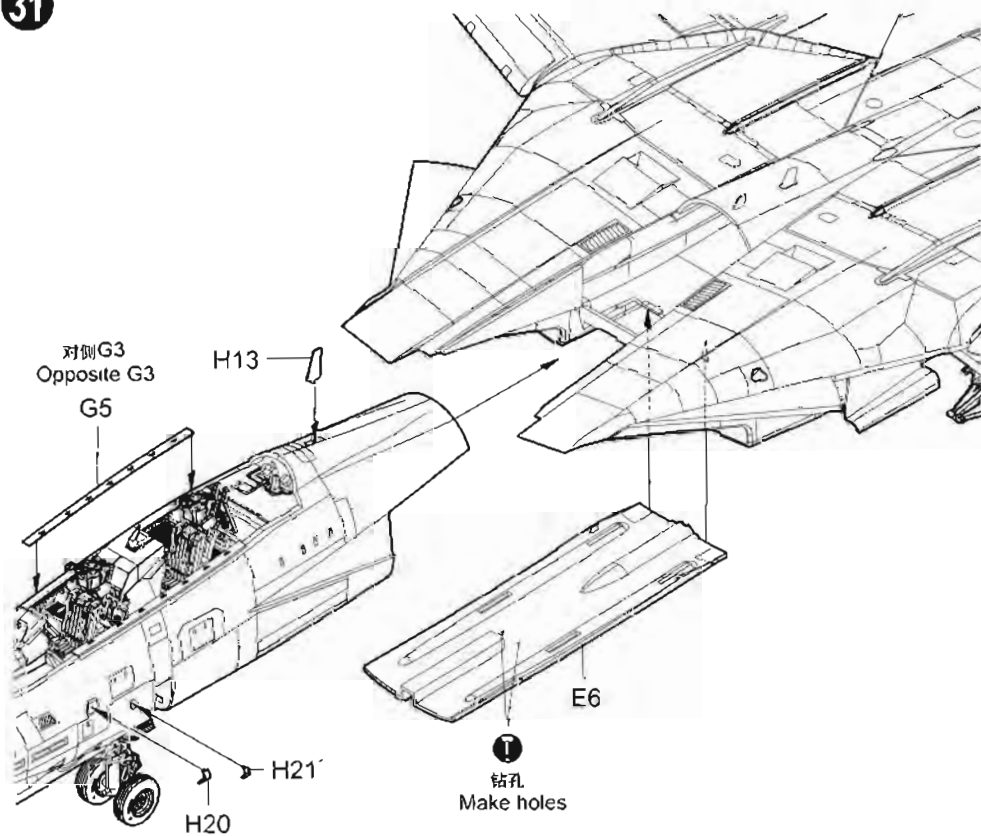

33

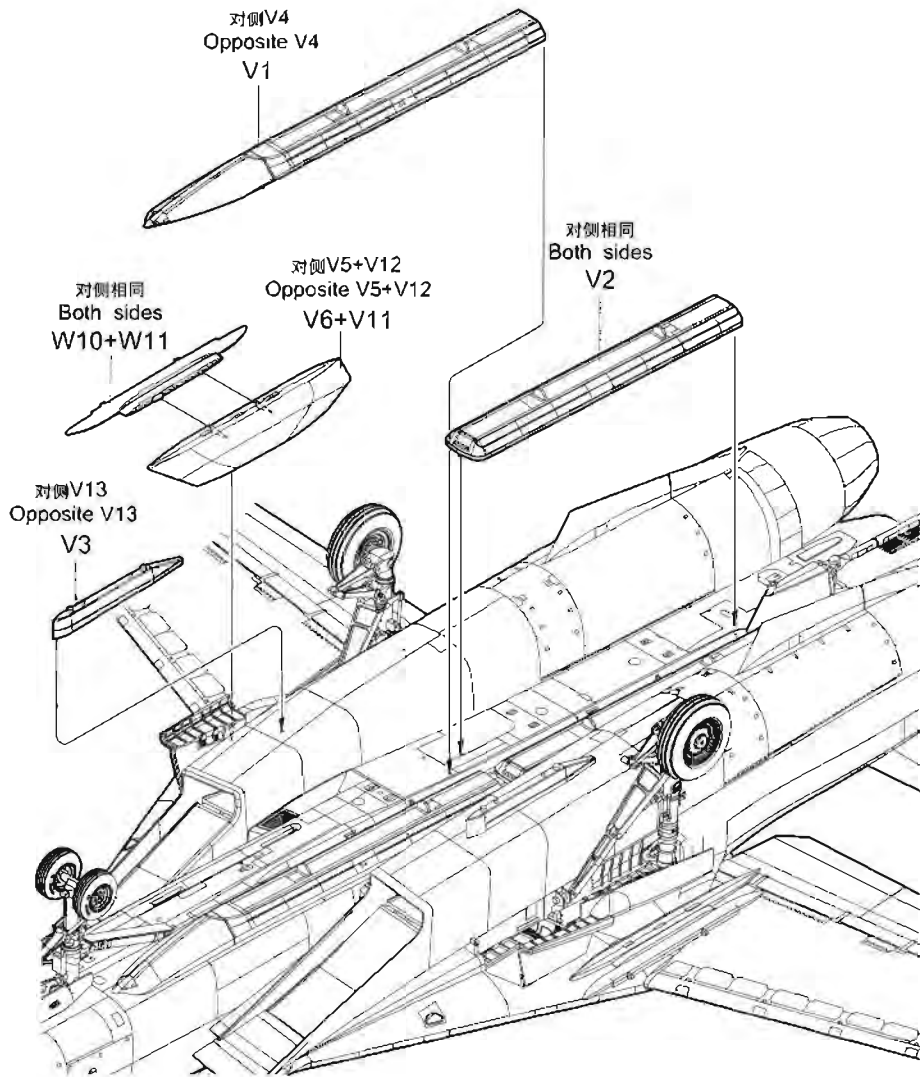

34

《AIM-9》

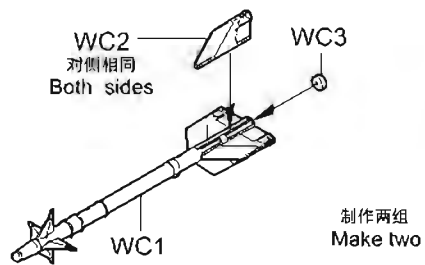

35

《Fuel Tank》

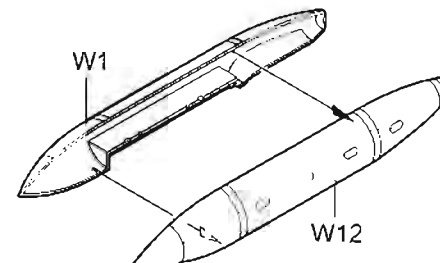

36

《AIM-7》

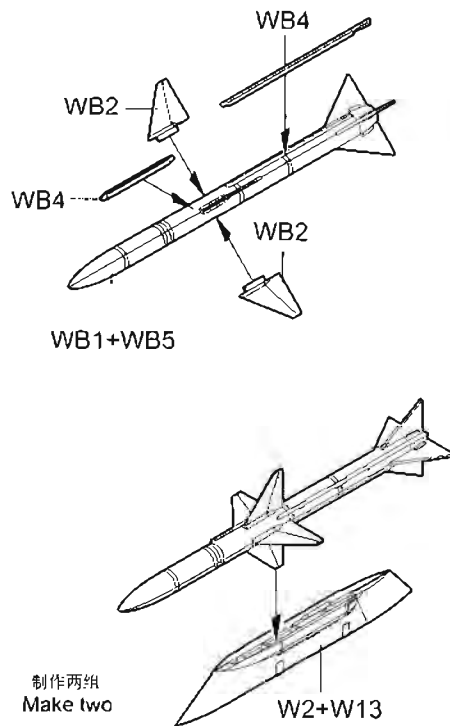

37

《AIM-54》

