

# M35A2 CARGO TRUCK

## M35A2載重車

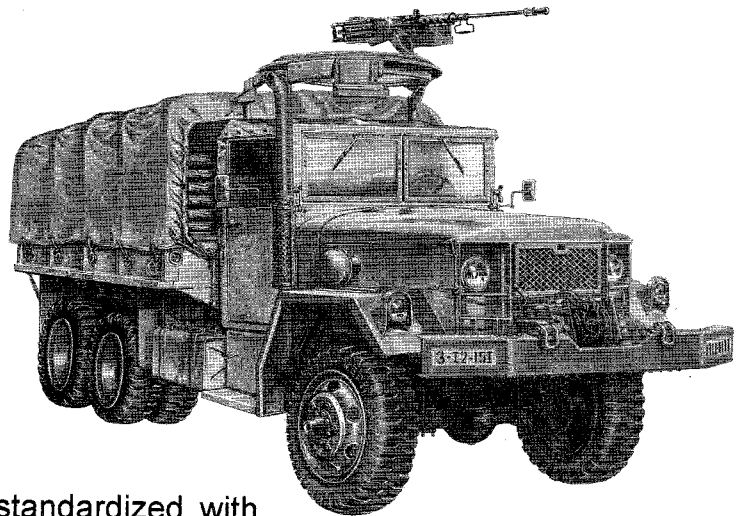

The core of U.S. Army truck fleet was standardized with GMC-CCKW353 during the WW II and its post war successor M35 2 1/2 ton truck was introduced in early '60 with multi fuel engine. And then after '70, M35A2 with diesel engine became standard truck of U.S. ground Forces and using by many Armies in the world including Taiwan, Korea, Israel and over 40 countries.

There are many variations based on the M35 truck such as wrecker, Dump, Fuel truck, Office. Tractor etc and traditional ring mount machine gun is equipped on the cab top of cargo version in combat zone. Also protected crew with armored plate on the cab and cargo body was provided on this truck during Vietnam series.

### M35A2 DATA:

Engine: Continental LD-465-1      Length: 7.06m      Width: 2.44m      Hight: 2.84m  
Weight: 6.22ton      Speed: 93 km/h

兩噸半卡車在美軍地面運輸部隊的需求中佔有相當份量,二次大戰中的 GMC-CCKW353 是服役最廣的運輸車輛,而戰後即著手開始研發其後繼車。1960 年代初期,以 GMC-CCKW353 為基礎而重新設計,制式編號為 M-35 的載重車被正式採用,1970 年代後經逐次修改而成 M-35A2 一直延用迄今,除了動力系統的修改外, M-35、M-35A1、M-35A2 在外觀上的差異不大。越南戰爭結束後,包括美國、中華民國、韓國、以色列等在內的 40 個國家均大量的採用,成為大戰結束後軍用載重車的代表作。

M-35 系列車輛因任務繁多而出現許多的衍生型,如:油罐車、工程車、救濟車等, M-35 載重車上搭載了傳統的機槍及環型槍架,越戰時尚有加裝裝甲板的武裝載重車出現。

### M35A2 載重車諸元:

動力:大陸 LD-465-1 引擎      全長(含絞盤):7.06 公尺      全寬:2.44 公尺  
全高(含棚布):2.84 公尺      總重:6.22 噸      最大速度:93 公里/小時

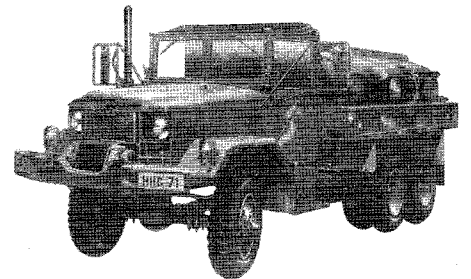

M49A2C FUEL TANK

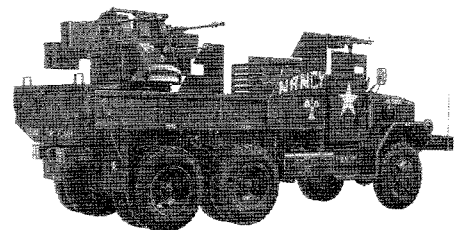

M35A1 GUN TRACK

アイウエオカキクケコサシスセソタチツテトナニヌネノハヒフヘホマミムメモヤユヨラ  
 リルレロワヰヱヲンカケよ

米軍の地上輸送力の中核を占める 2 ½トン・トラックは第二次大戦中の GMC-CCKW353  
 によつて全世界に知られるようにをり、戦後・はオートマライツフ・トランスミツシヨンの  
**M35** をどが造られましたガ、1960 年代初めからデー

ゼル、ジエツト燃料、ガソリンなどが使用できる多燃料エンジンの **M35** を使用。1970 年  
 代からカイザー・ジープ社がディーセル・エンジンの **M35A2** な制式化、今日に至つています。  
 エンジン以外の外形では **M35**、**M-35A1**、**M-35A2** はほとんど同じでヴエトナム戦争以後、  
 全世界に展開する米軍のほか、台湾、韓国、イスラエルその他 40 か国以上の陸軍で使用さ  
 れており、戦後の軍用トラックの代名詞とさえ言われています。

**M35** シリーズ・トラックにはレッカー、ダンプ、タンクローリー、その他多くの  
 ヴァリエーションがあい、標準型のトラックには伝統的をリング・マウント・ガンが搭載さ  
 れるほか、ヴエトナム戦争中は装甲板でキャブ・荷台を保護するためのキットも配布されて  
 います。

**M35A2** トラック諸元:

エンジン:LD-465-1 エンジン 全長:7.06m 全幅:2.44m 全高:2.84m  
 重量:6.22t 最大速度:時速 93km

Illustration: 圖示説明



Method For Applying Decals:

1. Clean Model Surface With Wet Cloth.
2. Cut Out Of Decal Sheet And Dip Them In Water For 15 Seconds.
3. Place it on proper position on model.
4. Slide off base paper leaving decals On Model With Wet Finger Tip.
5. Move Decals To Exact Position, Push Out Excess Water Under Decal With Soft Cotton Cloth.
6. When Decals Get Dry Then Complete.

水貼紙使用説明:

1. 將模型表面擦乾淨
2. 將貼紙剪下泡入清水中約15秒
3. 將泡濕之貼紙取出置於欲貼處旁
4. 用指尖輕推貼紙表面使其滑出底紙
5. 將貼紙調整至適當位置並輕擦拭水份
6. 待其自然乾燥後即完成

Color list: 塗料表

Color	Brand	Gunze Sangyo			Humbrol	Revell
		Hobby Color	Mr. Color	Mr. Color Spray		
Olive drab	橄欖綠	H-78	C-38	J-38	66	46
Steel	黑鐵	H-18	C-28	J-28	53	91
Red	紅	H-3	C-3	J-3	19	31
Red brown	紅褐	H-47	C-41	J-44	160	383
Silver	銀	H-8	C-8	J-8	11	90
Black	黑	H-2	C-2	J-2	21	07
Orange	橘色	H-14	C-59		18	30
Steel red	赤鐵	H-38			160	383
RLM sand yellow	沙黃	H-66	C-119		187	16
Brass	黃銅	H-9	C-9	J-9	54	92
Bronze green RAL 6031	銅綠		TC-10		88	65
Leather brown RAL 8027	皮革		TC-11		160	84
Tar black RAL 9021	瀝青		TC-12		91	06

M35A2配備附多重選擇性如：  
 絞盤 機槍架 承載盤的座椅等  
 請注意各項配備說明及指示

THERE ARE MANY DIFFERENT KINDS OF  
 FUNCTION CAN BE CHOICED BY THIS  
 M35A2 TRUCK MODEL.  
 PLEASE READ INSTRUCTI-  
 ONS CAREFULLY BEFORE  
 YOU DO THE JOB.

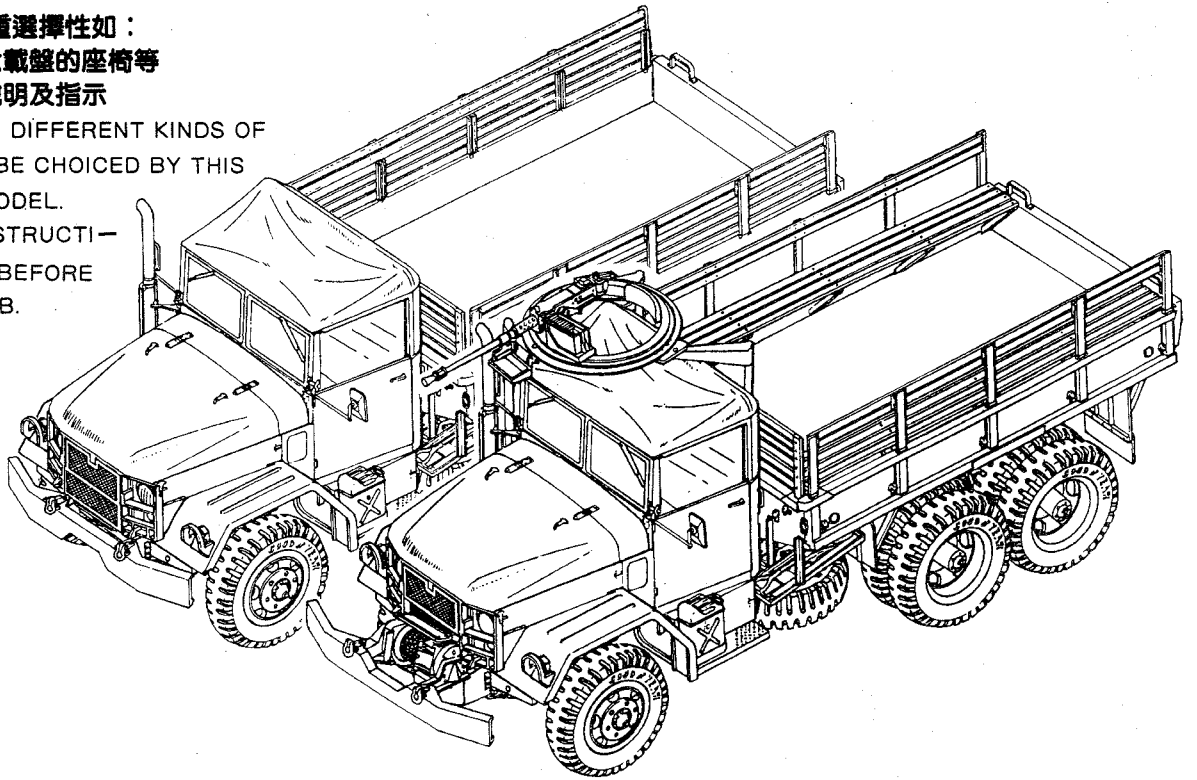

**1**

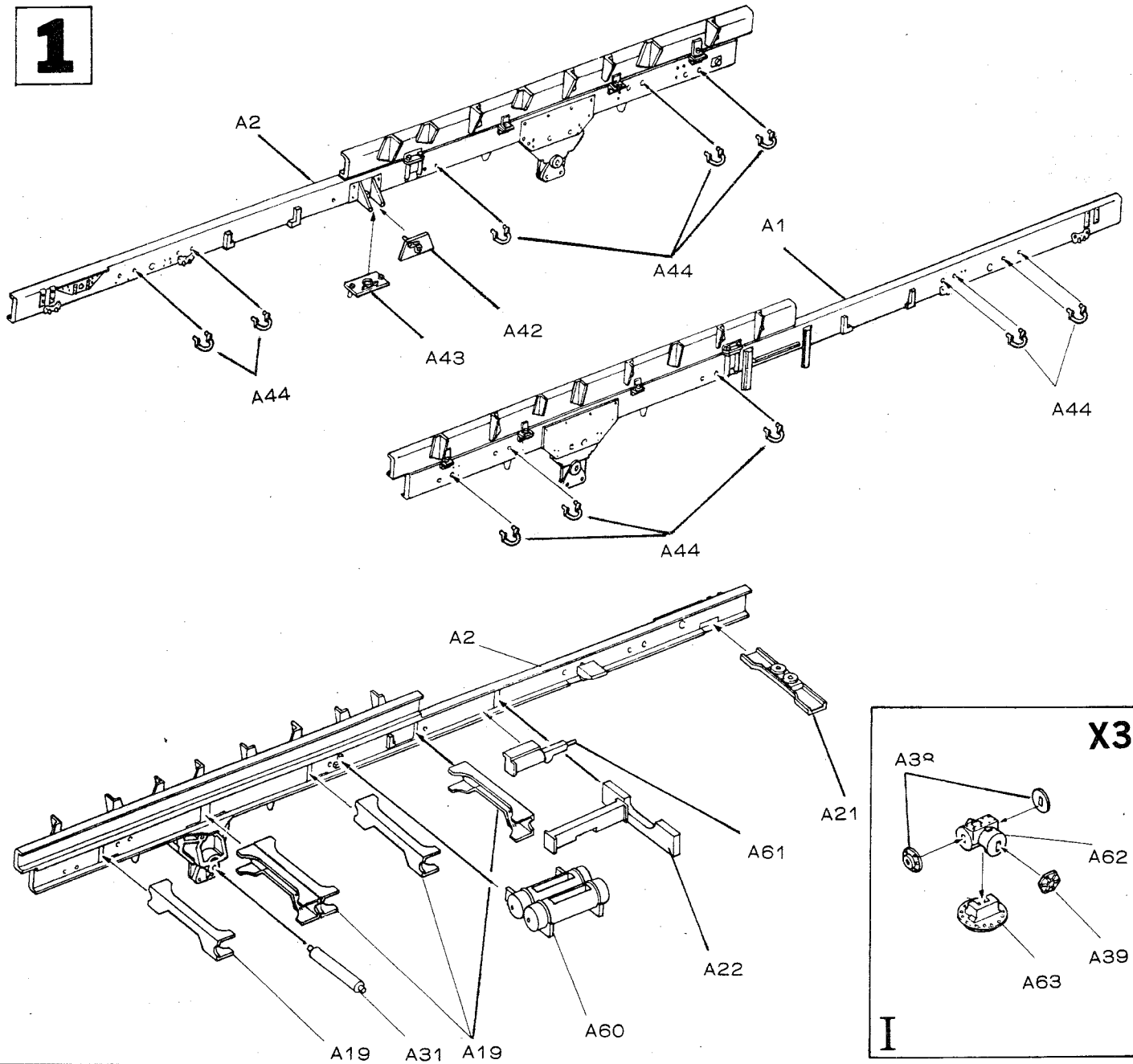

2

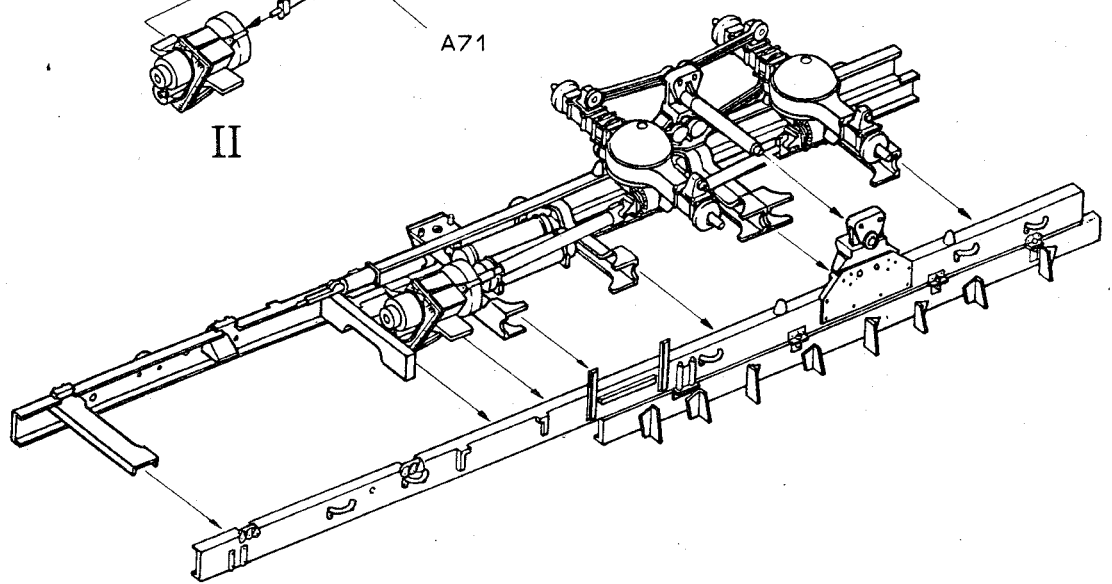
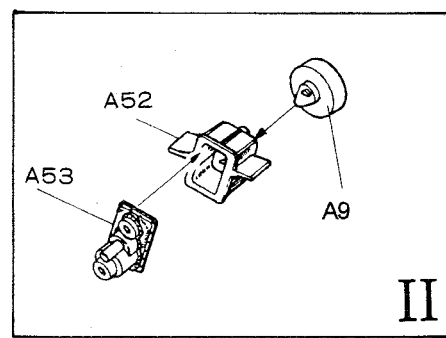
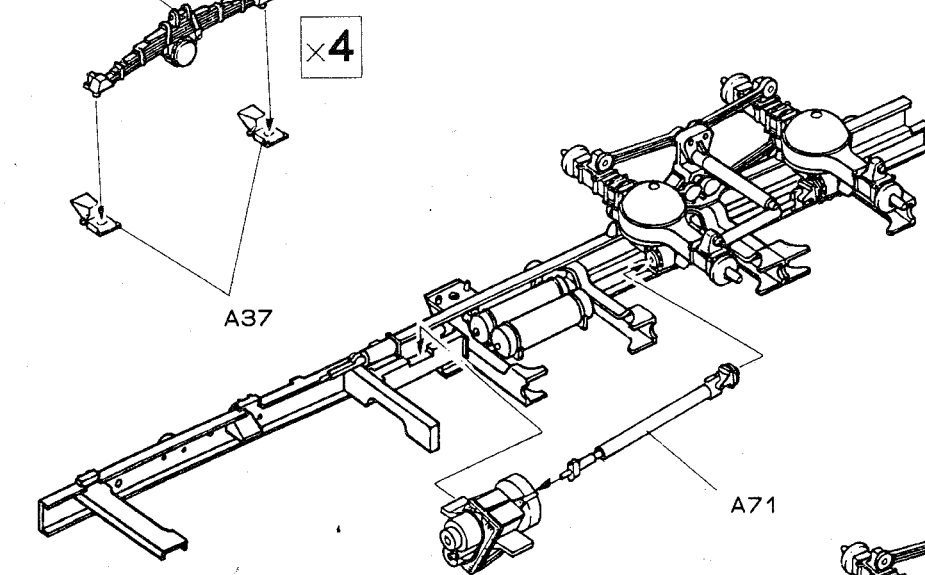
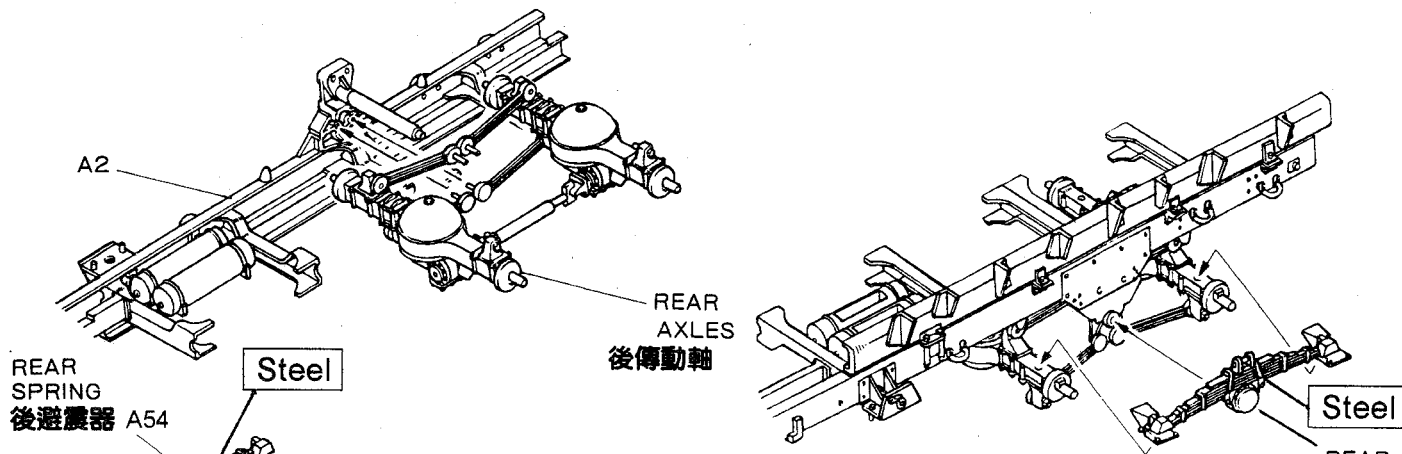
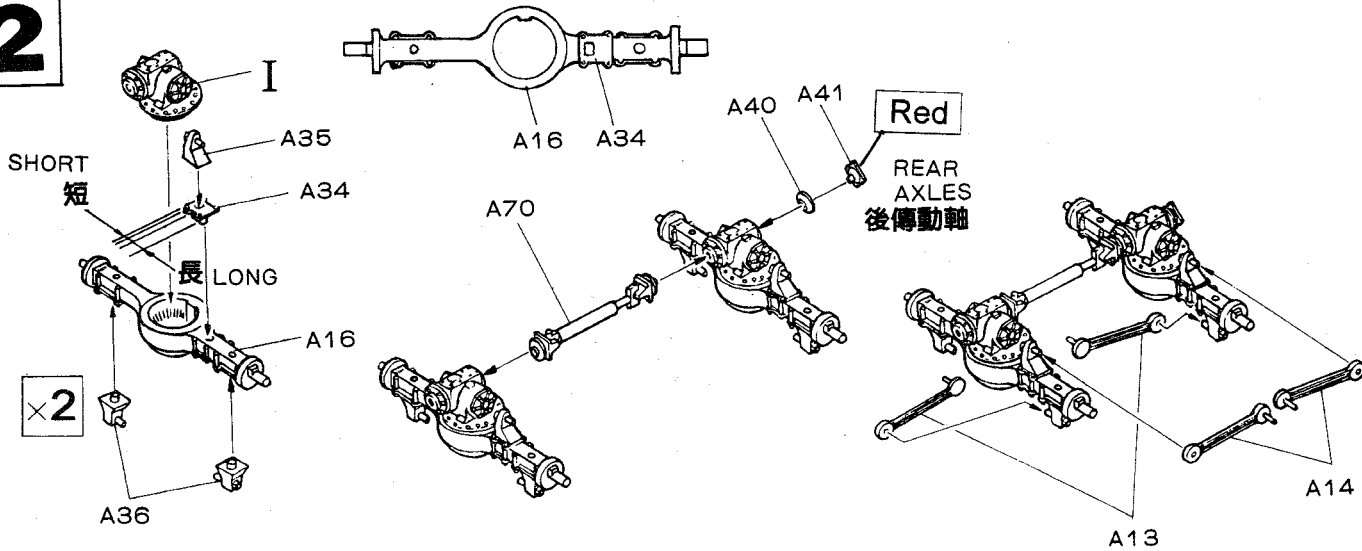

3

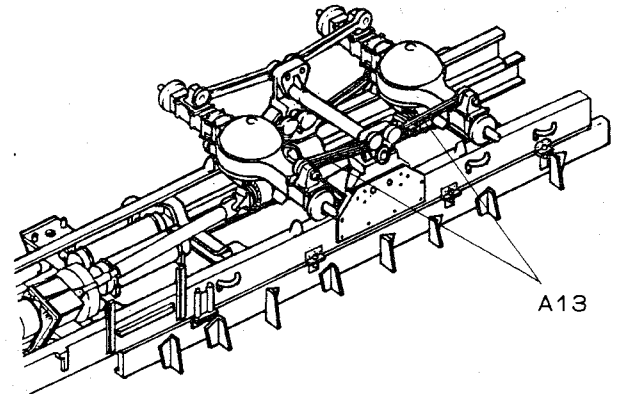
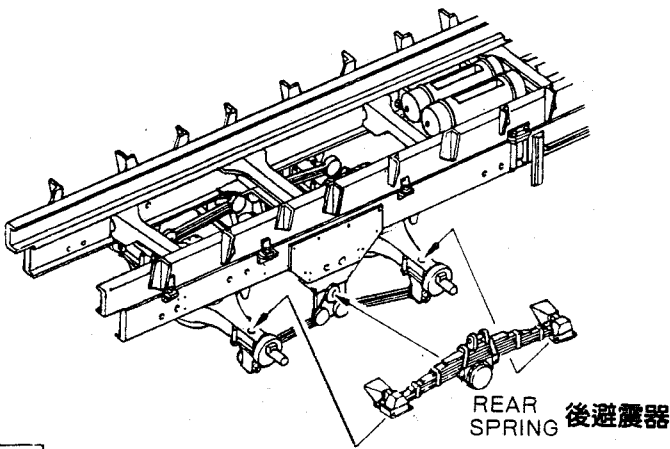
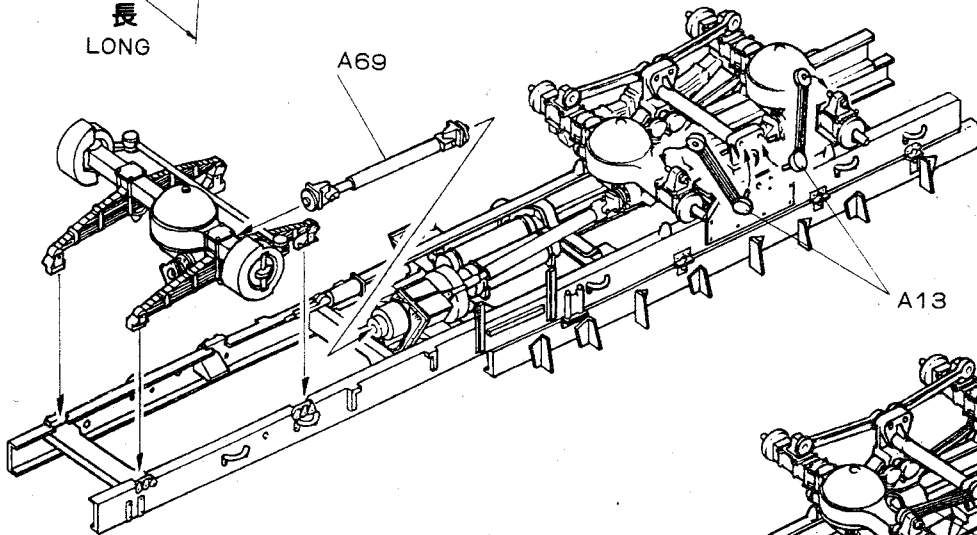
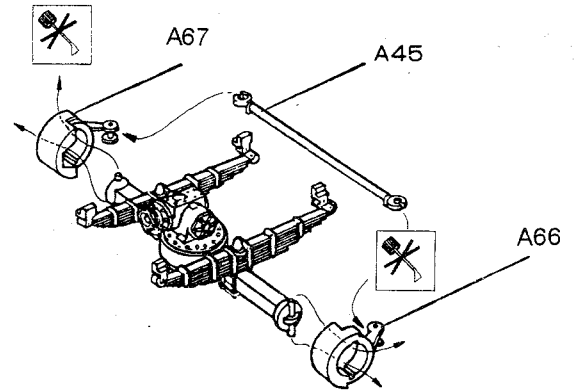
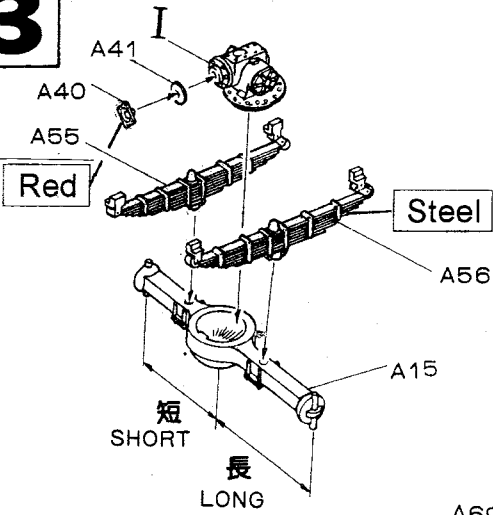

4

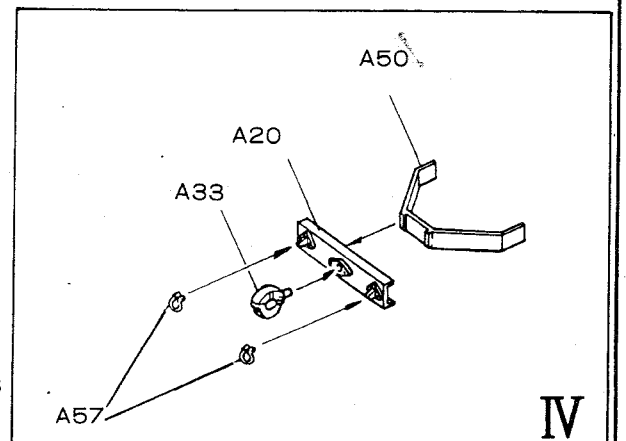
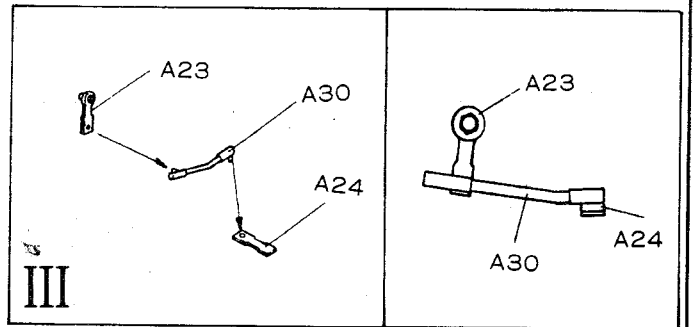
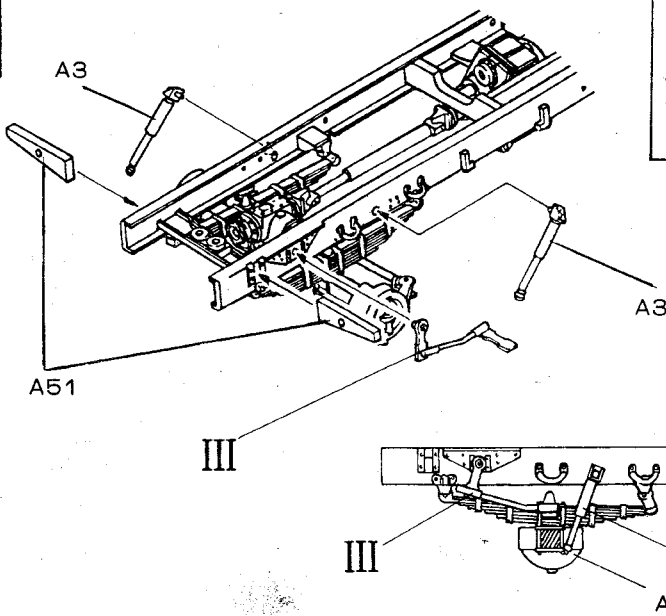

5

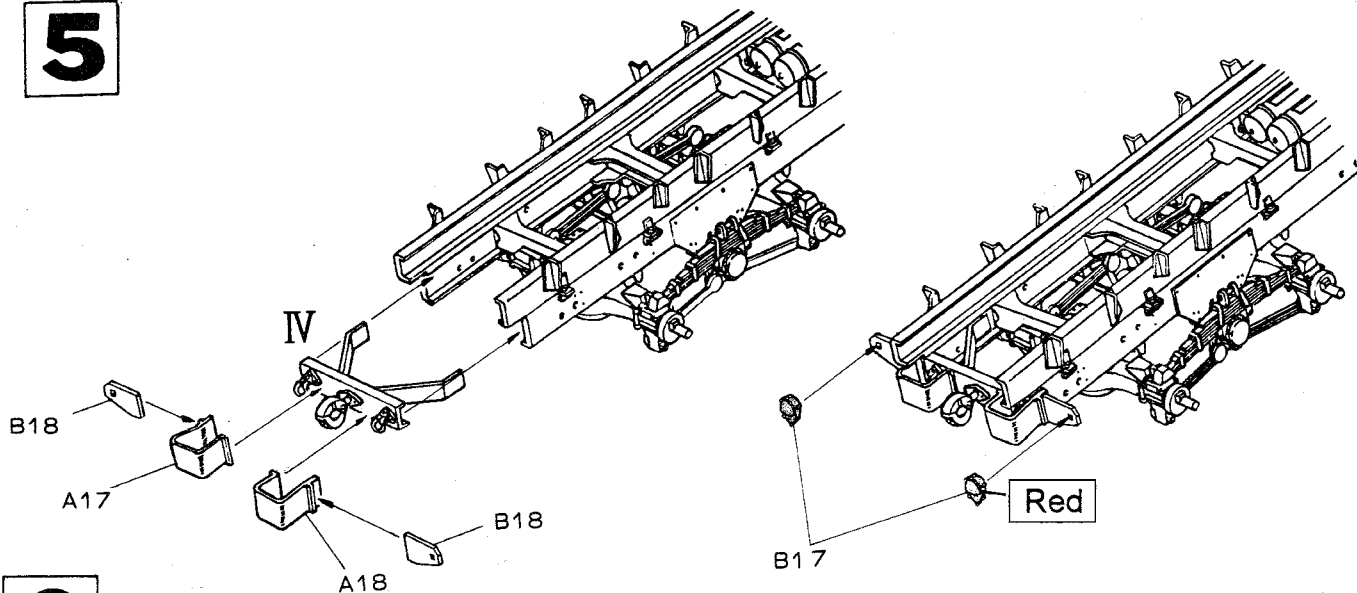

6

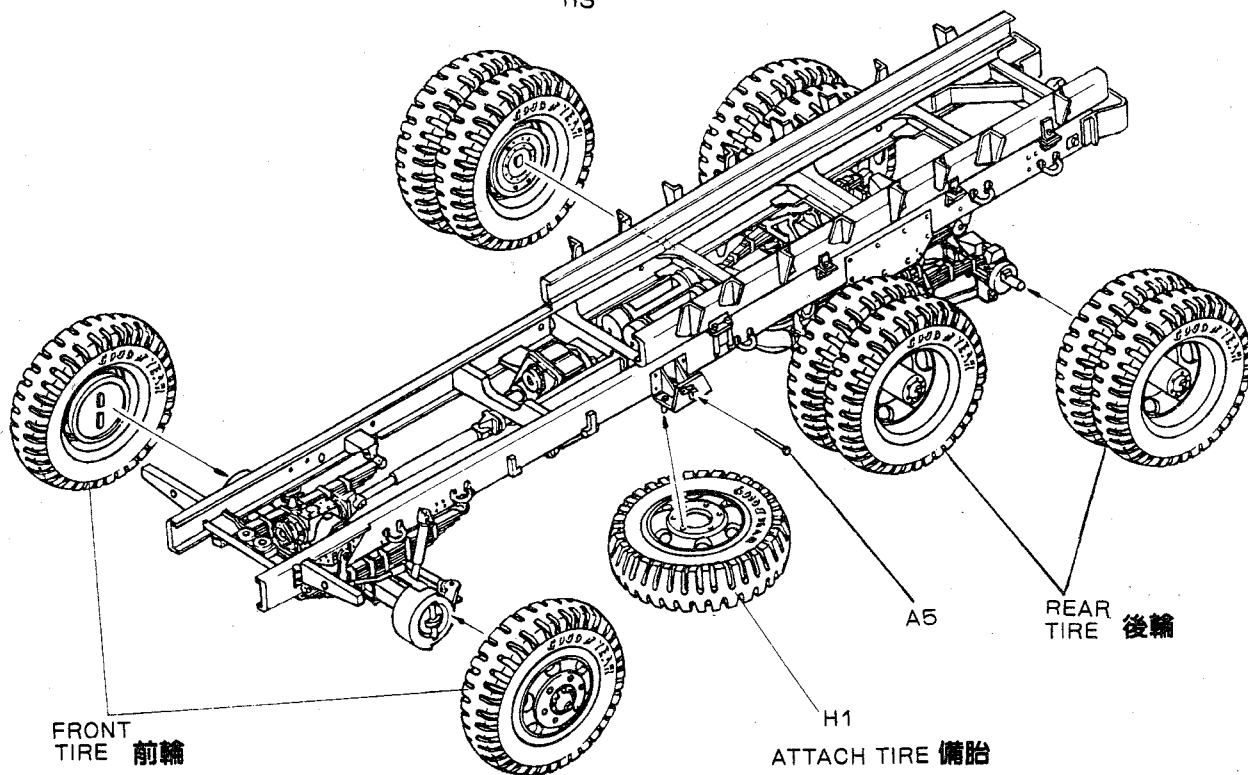
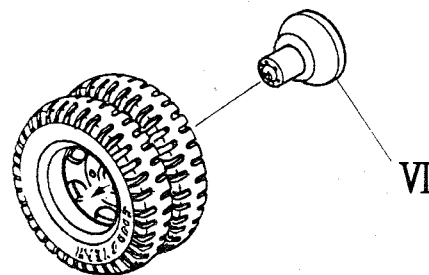
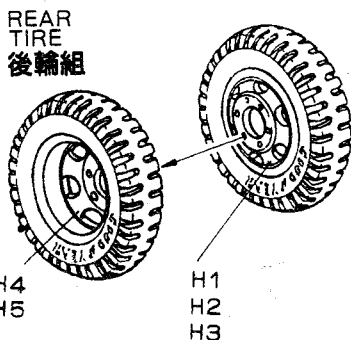
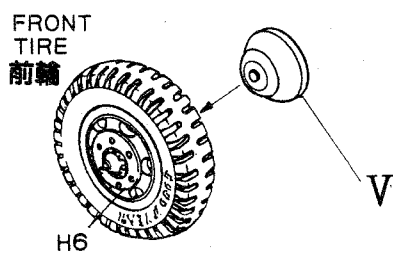
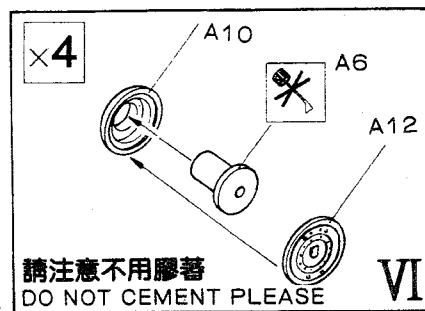
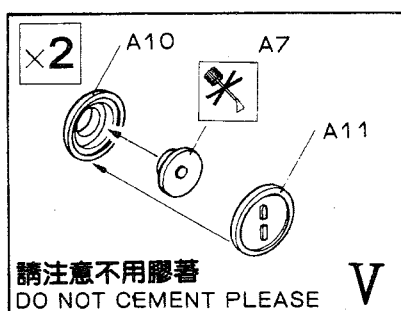
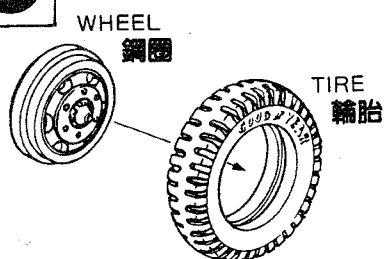

7

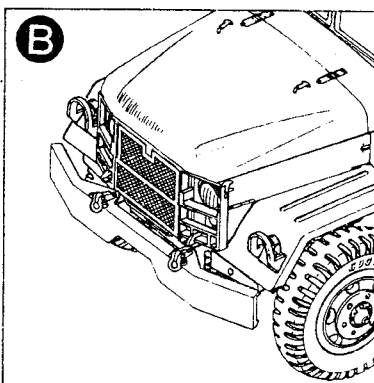
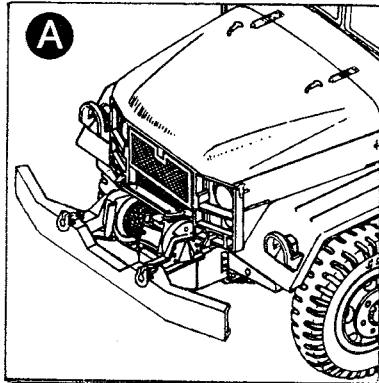
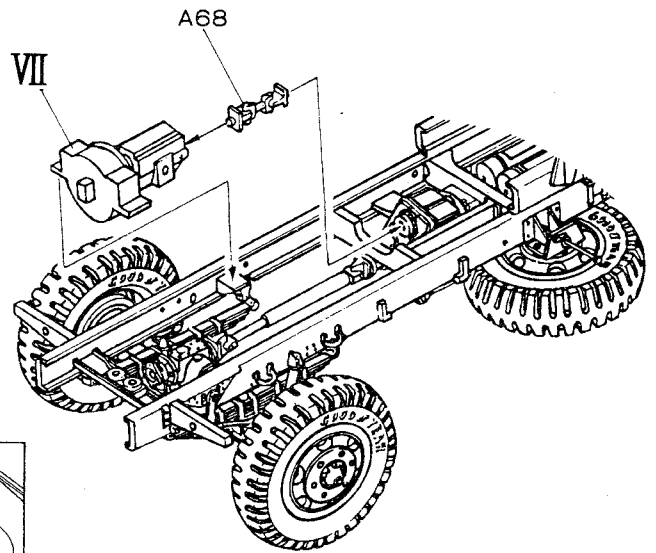
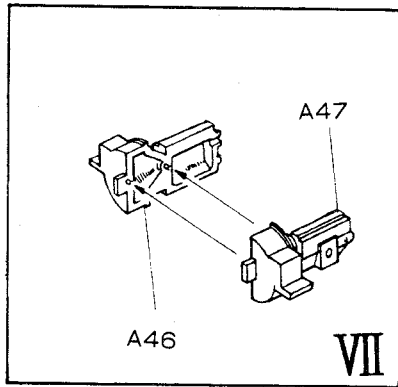

附絞盤製作請參考A步驟  
STEP A: WITH LAPSTAB

無絞盤製作請參考B步驟  
STEP B: WITHOUT LAPSTAB

A1

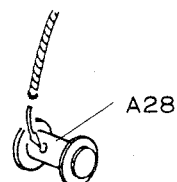

A2

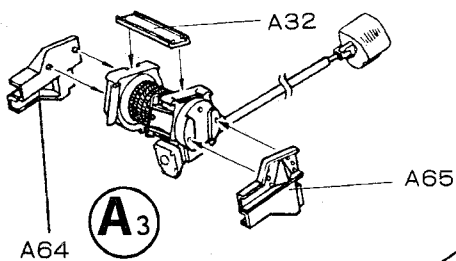
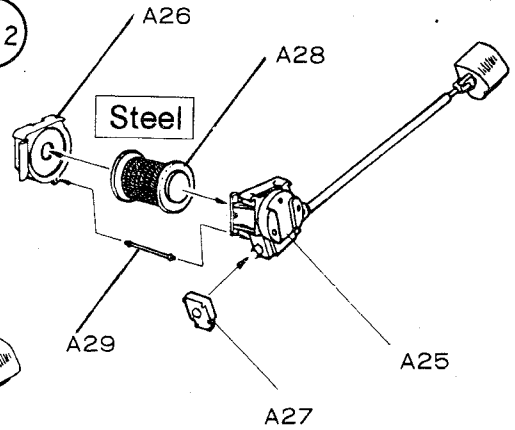

A4

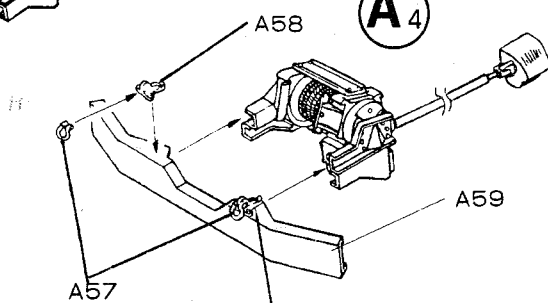

A5

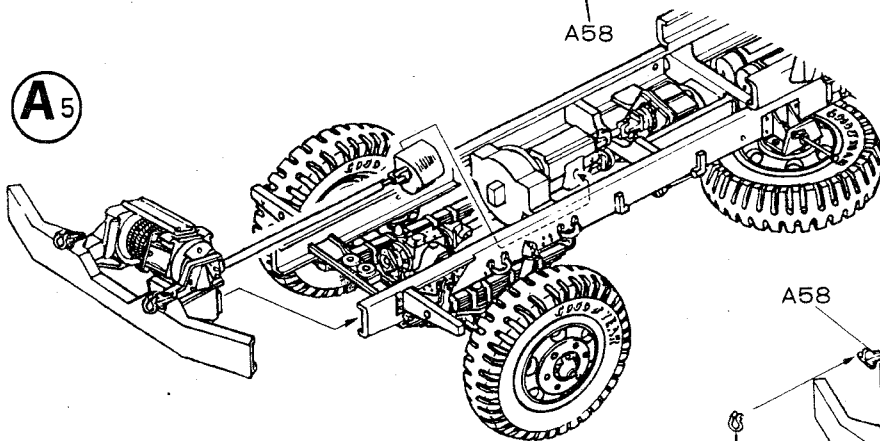

B1

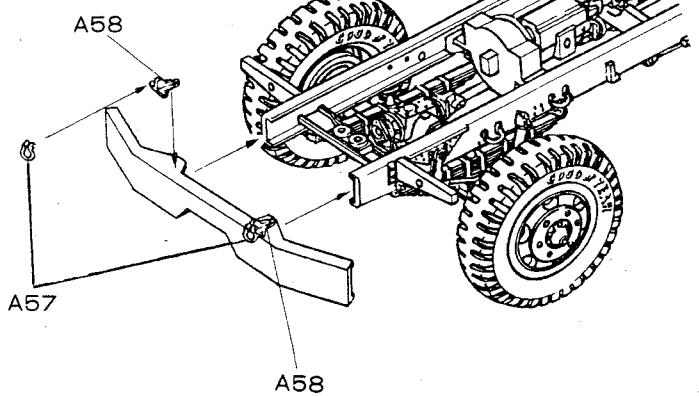

8

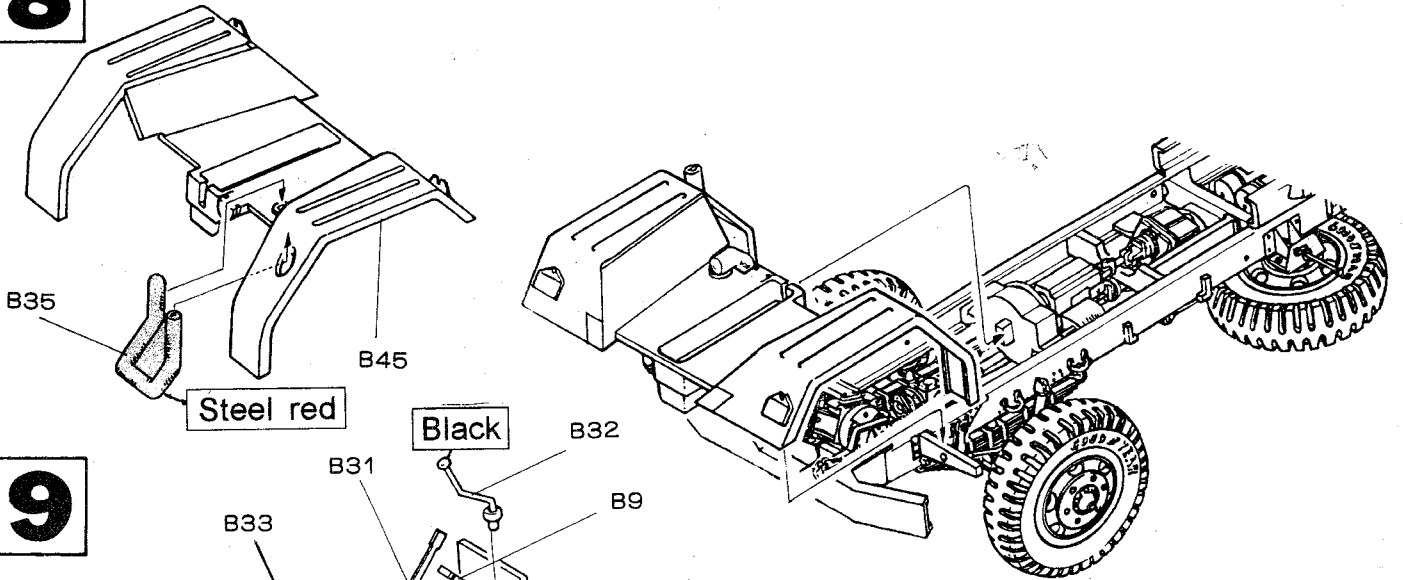

9

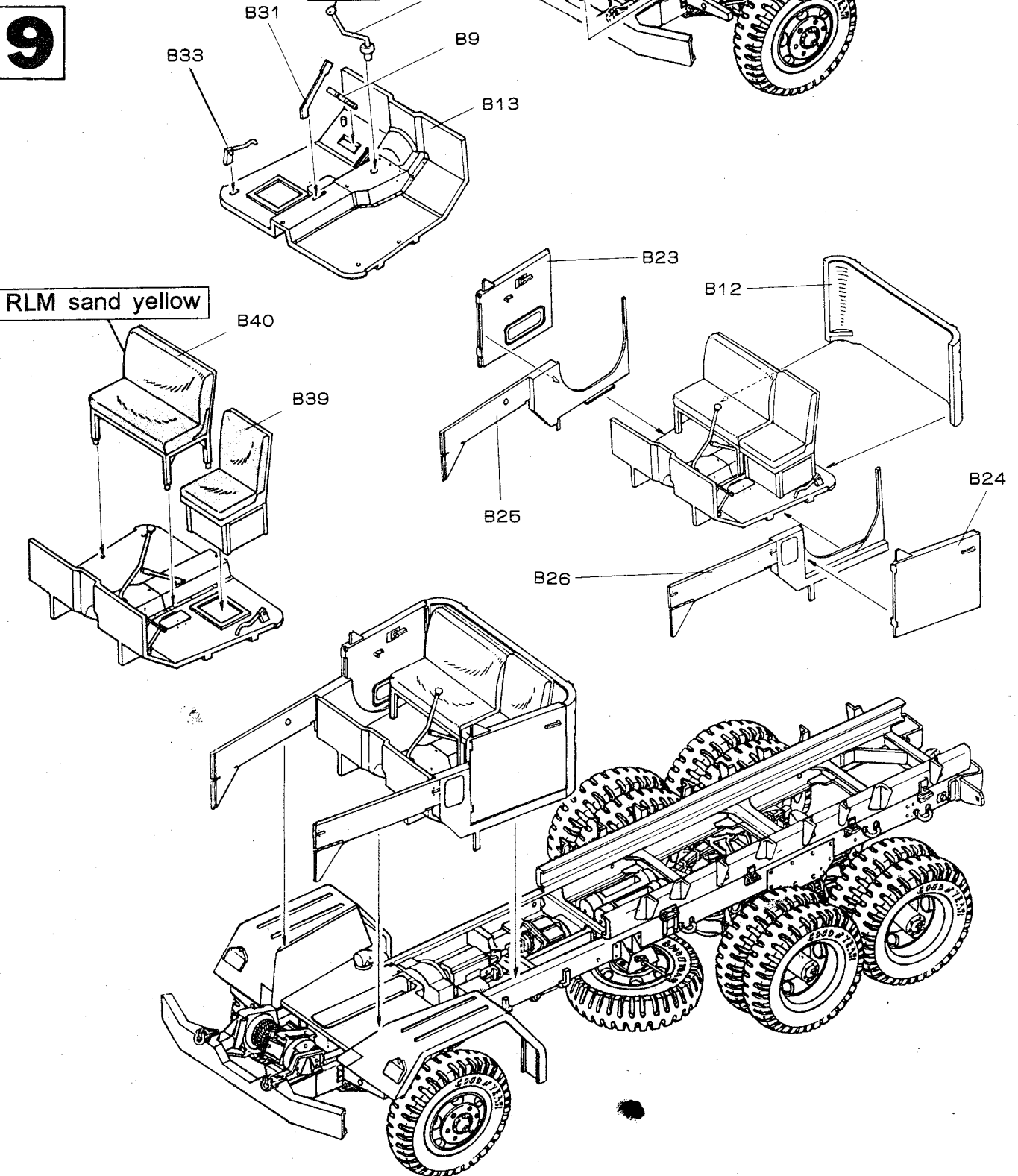



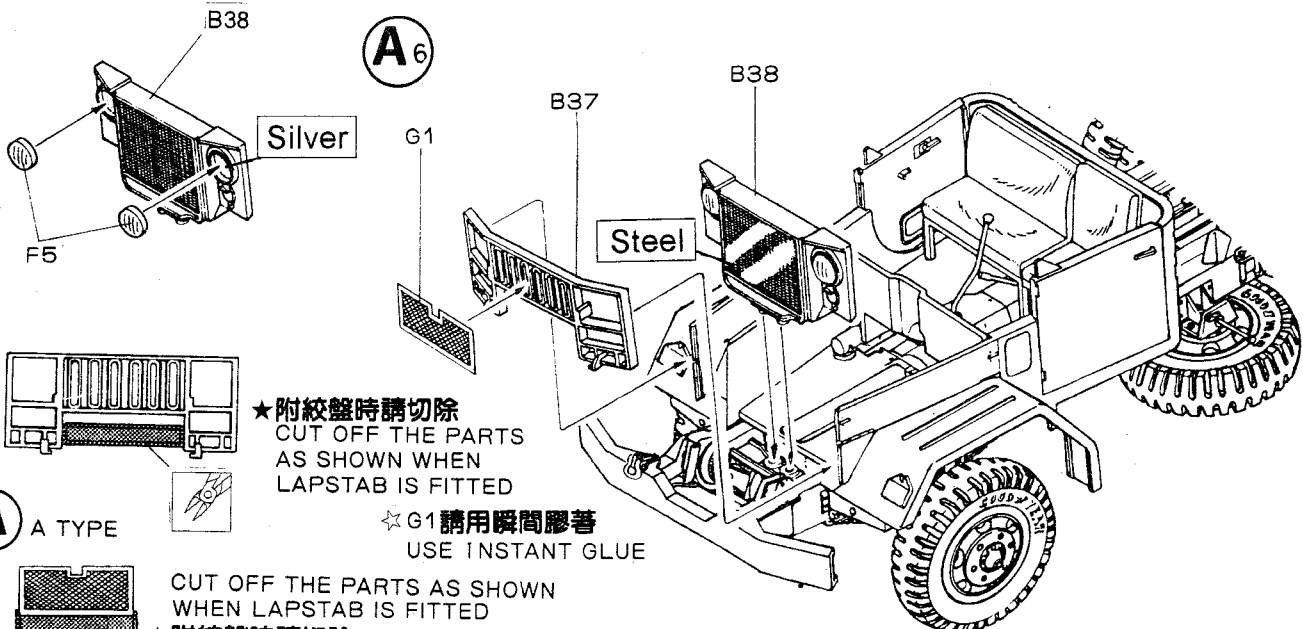

★附絞盤時請切除  
CUT OFF THE PARTS  
AS SHOWN WHEN  
LAPSTAB IS FITTED

☆G1 請用瞬間膠著  
USE INSTANT GLUE

**A** A TYPE

CUT OFF THE PARTS AS SHOWN  
WHEN LAPSTAB IS FITTED  
★附絞盤時請切除

**A** A TYPE

**B<sub>2</sub>**

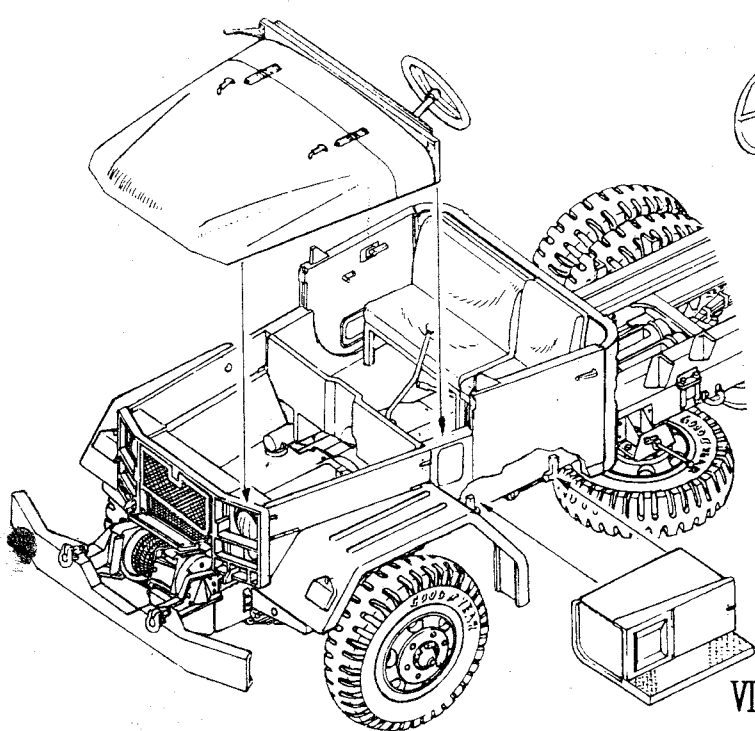
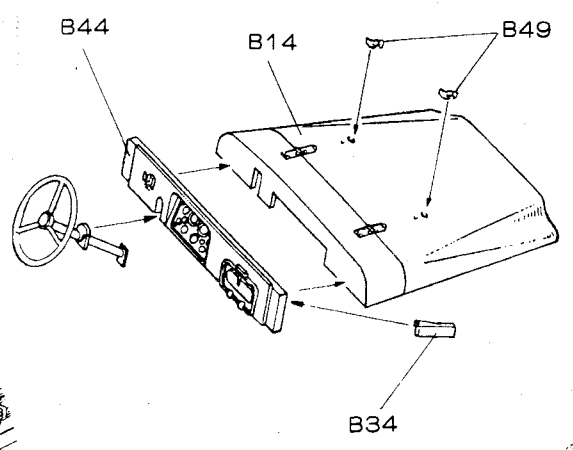
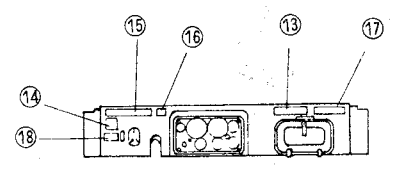
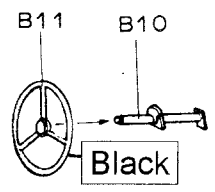
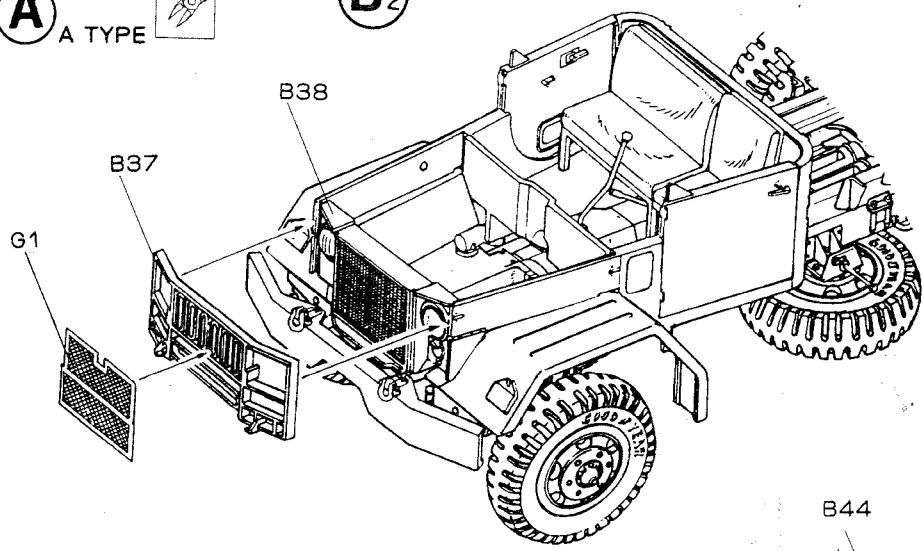

VIII

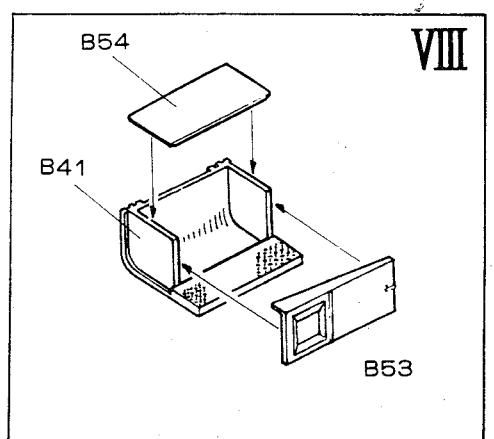

VIII

B53

10

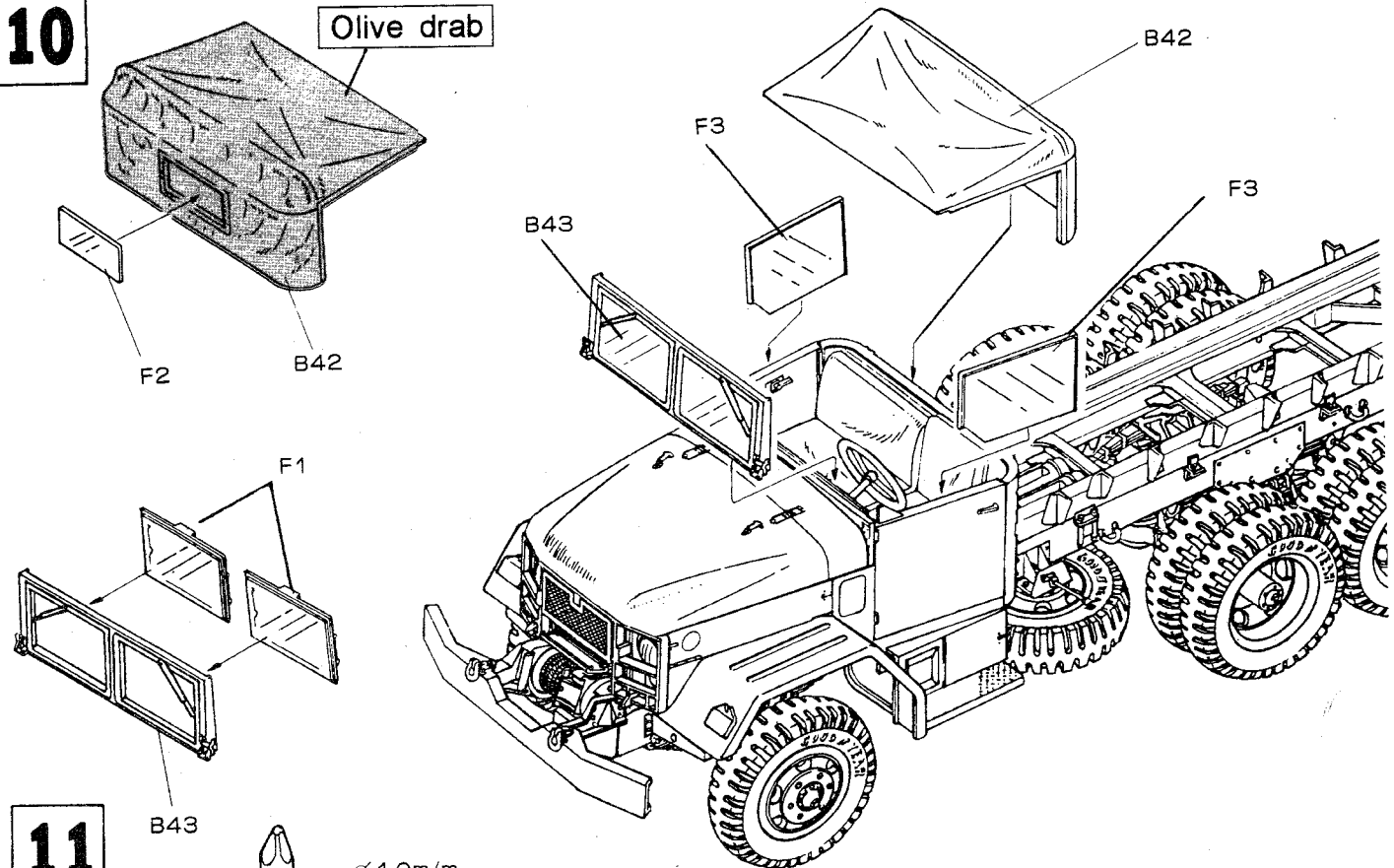

11

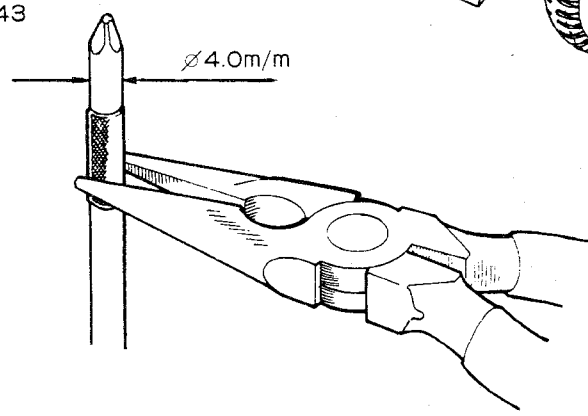

組合時請用尖咀鉗將G2彎曲成型  
 CURVE THE PART G2 WITH TOOLS

IX

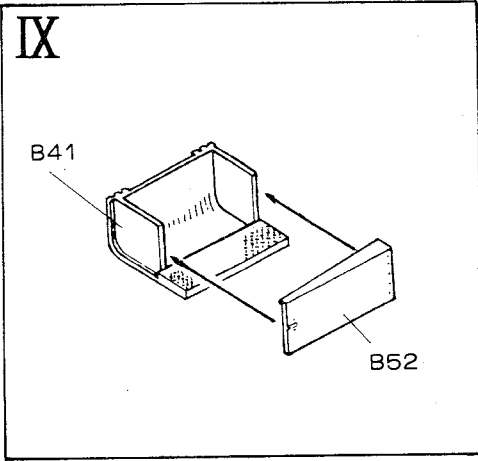

X

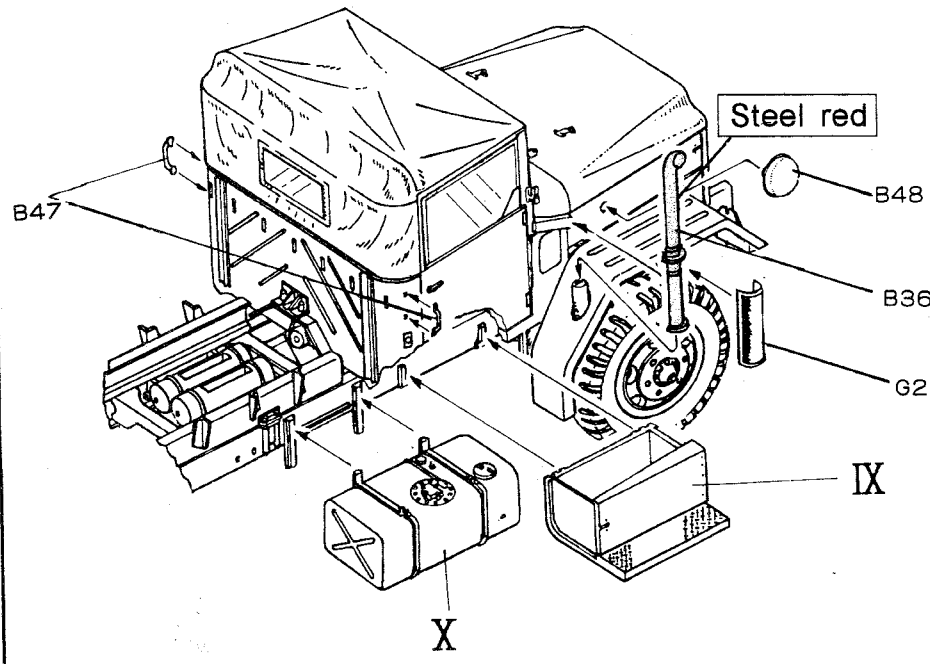
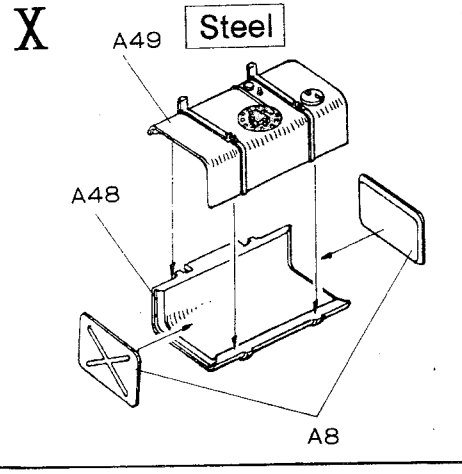

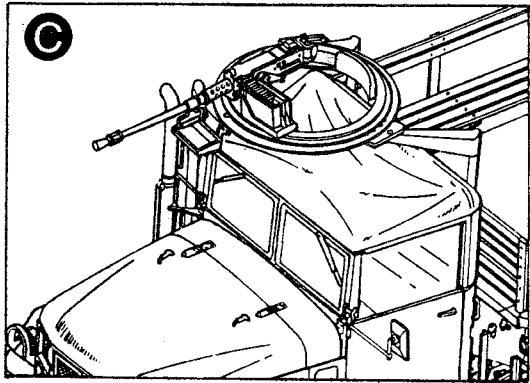

附機槍架時製作參考C步驟  
STEP C: WITH MG MOUNTING

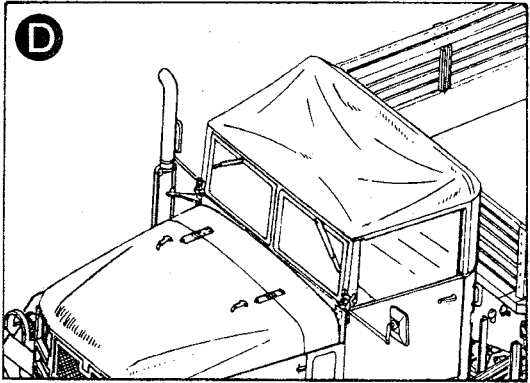
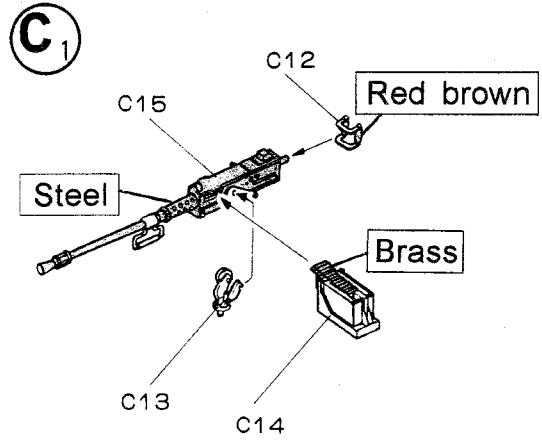

無機槍架時製作請參考D步驟  
STEP D: WITHOUT MG MOUNTING

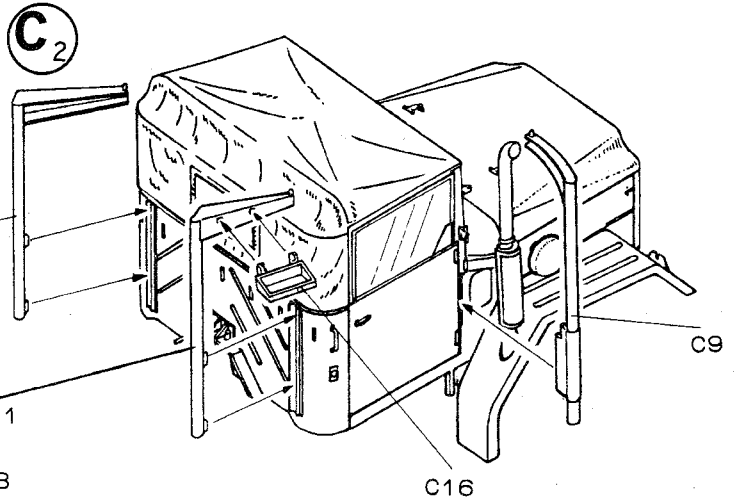

C3

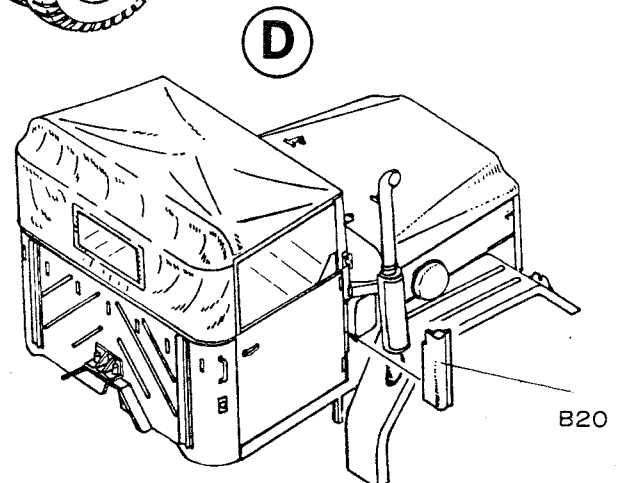
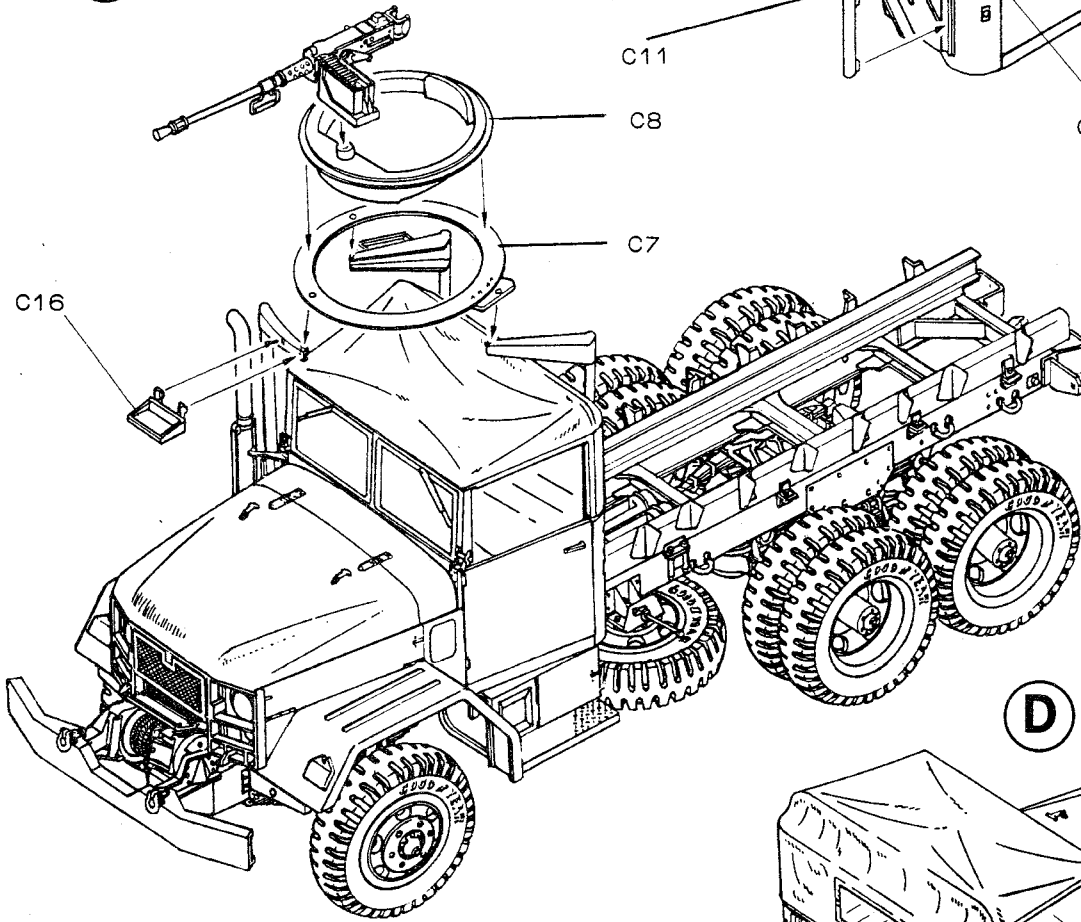

B20

12

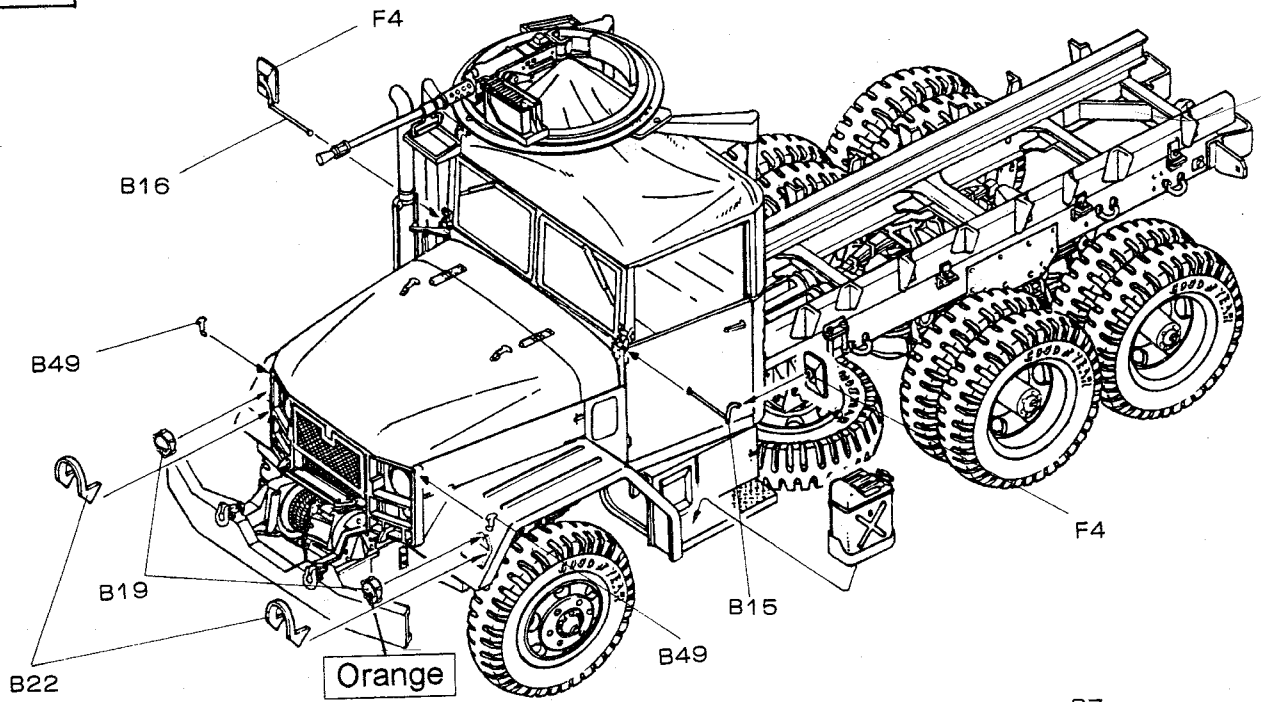

13

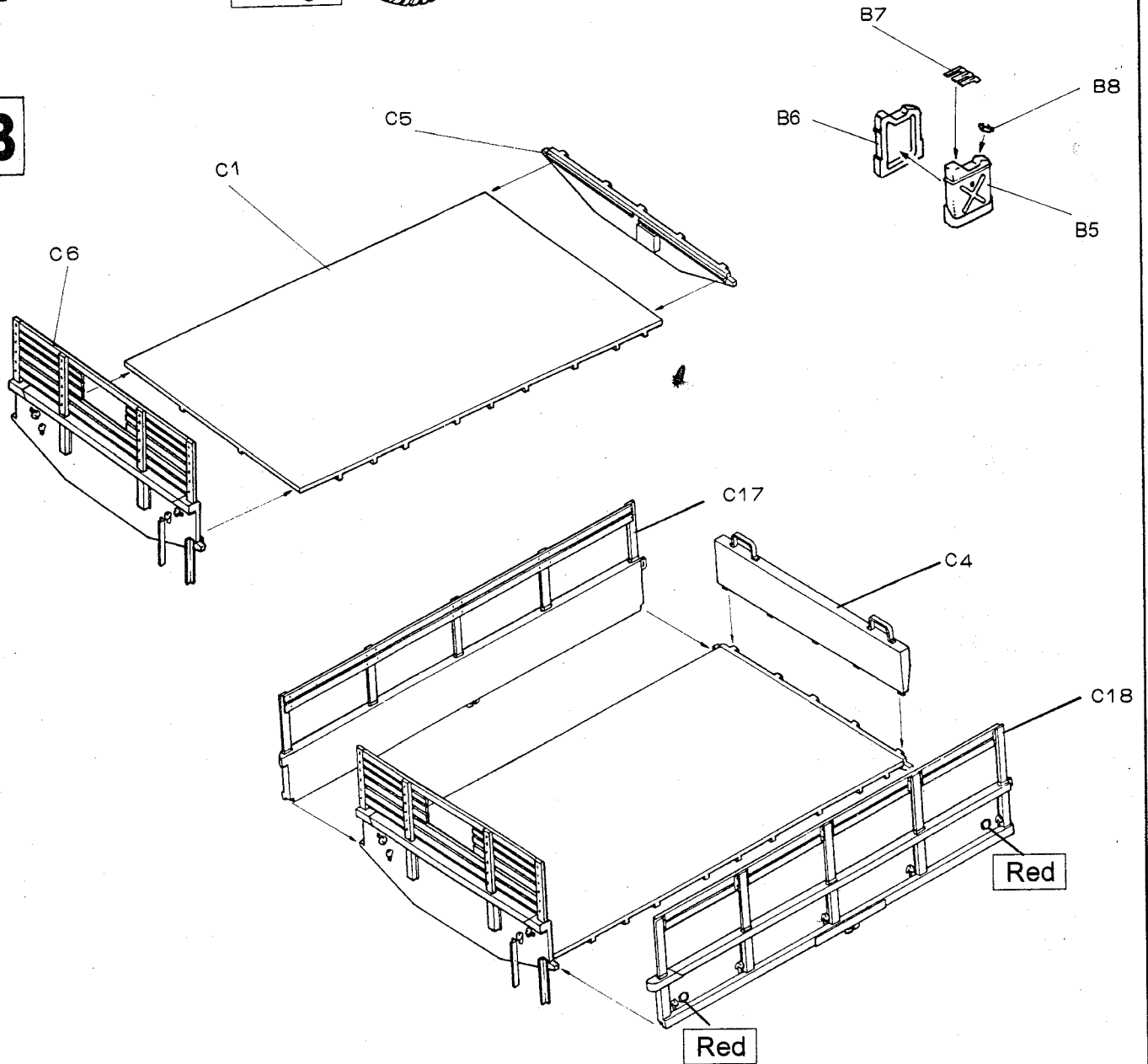

承載盤座椅放下時  
製作請參考E步驟

B30

B50

STEPE: BENCH  
LAY DOWN  
POSITION

B27

B51

B28

B51

B29

B50

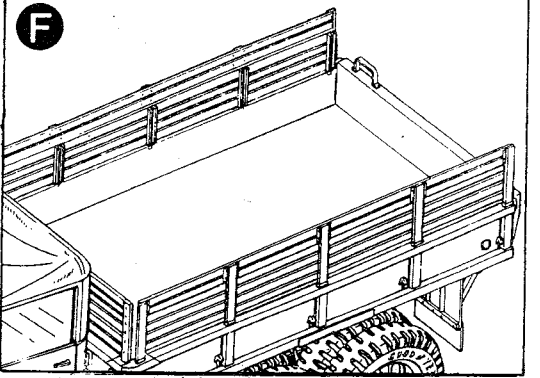
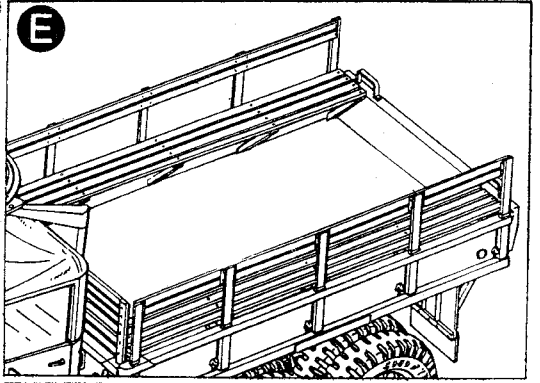

承載盤座椅收起時製作請參考F步驟  
STEPF: BENCH COLSE UP POSITION

E<sub>2</sub>

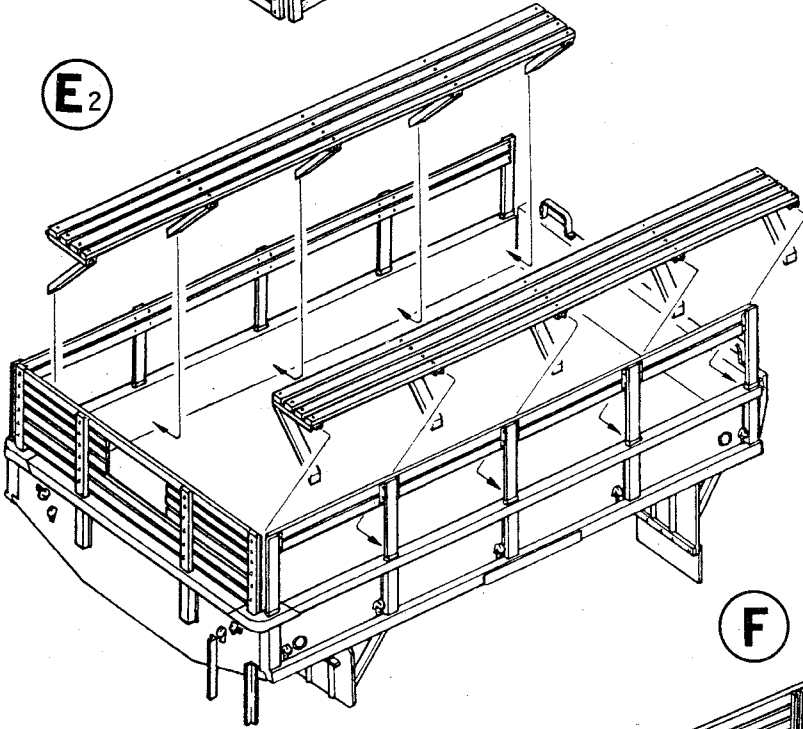

E<sub>1</sub>

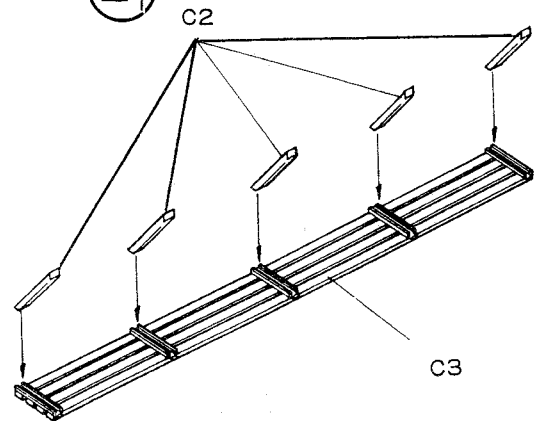

C2

C3

F

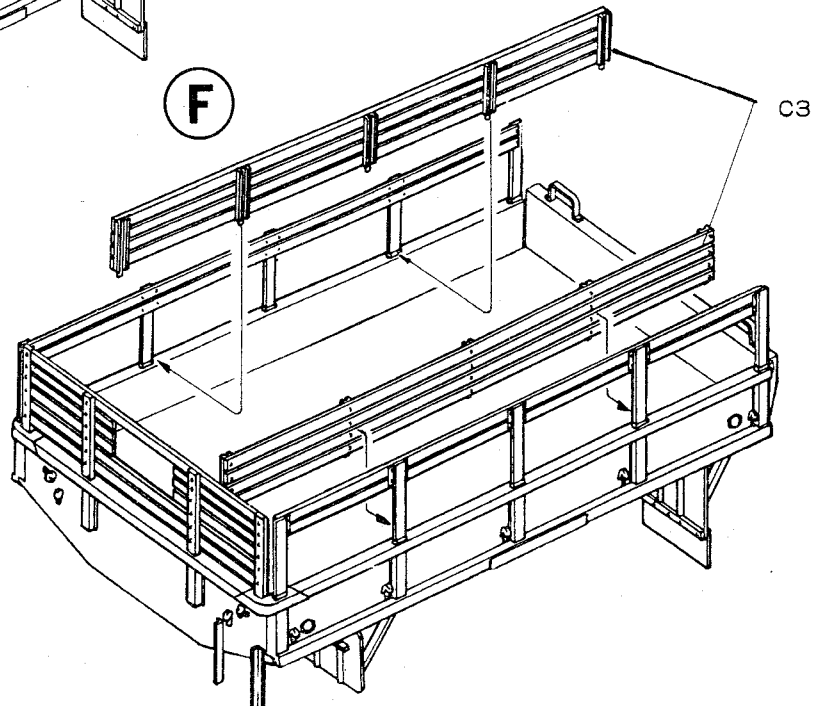

C3

**XI** B1 Steel

Red brown

B21

B2

B3

B46

B4不需使用  
PART B4 USELESS

14

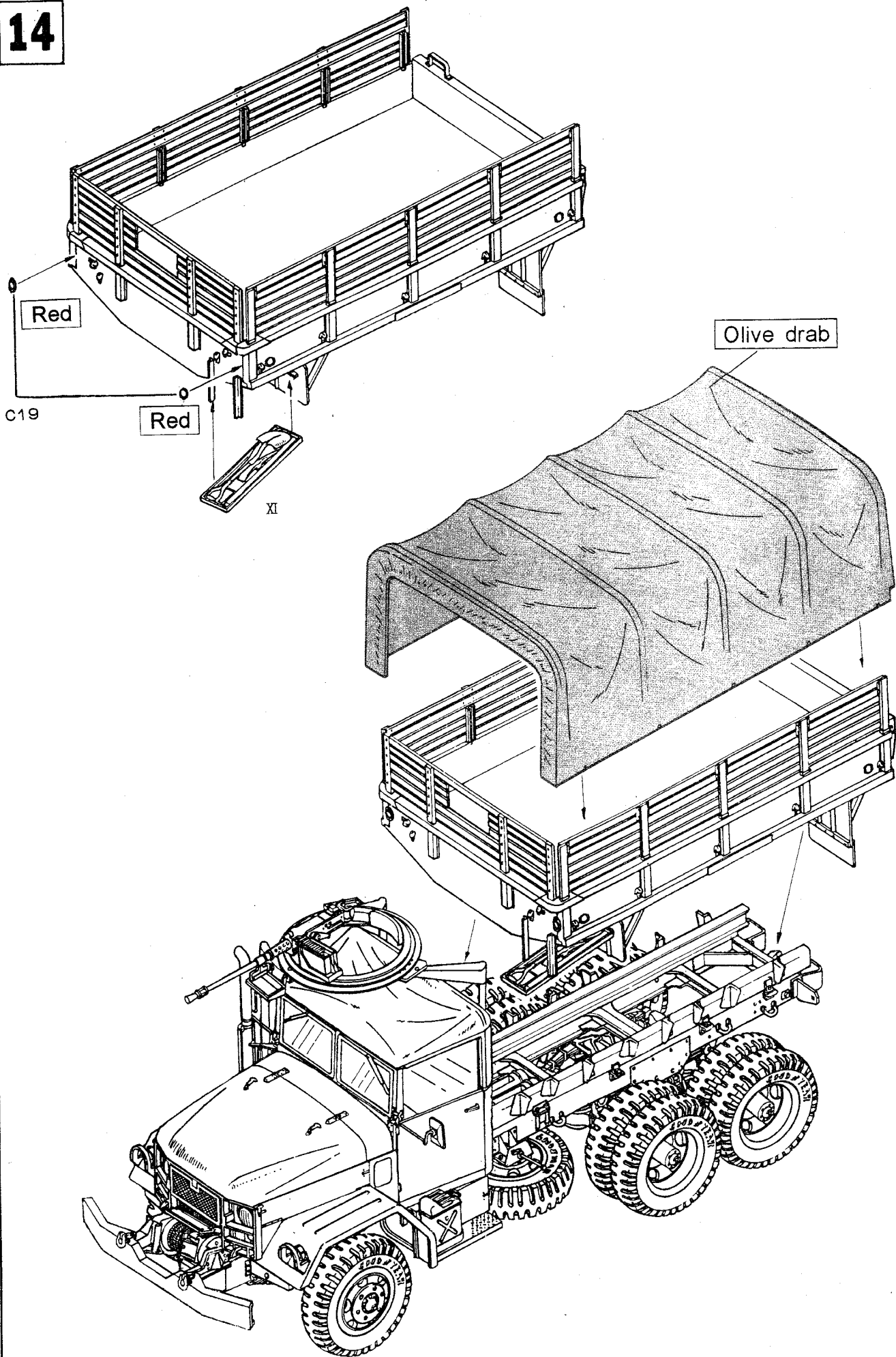

完成圖 附機槍及絞盤型M35A2

COMPLETE M35A2 WITH MG  
MOUNTRING & LAPSTAB

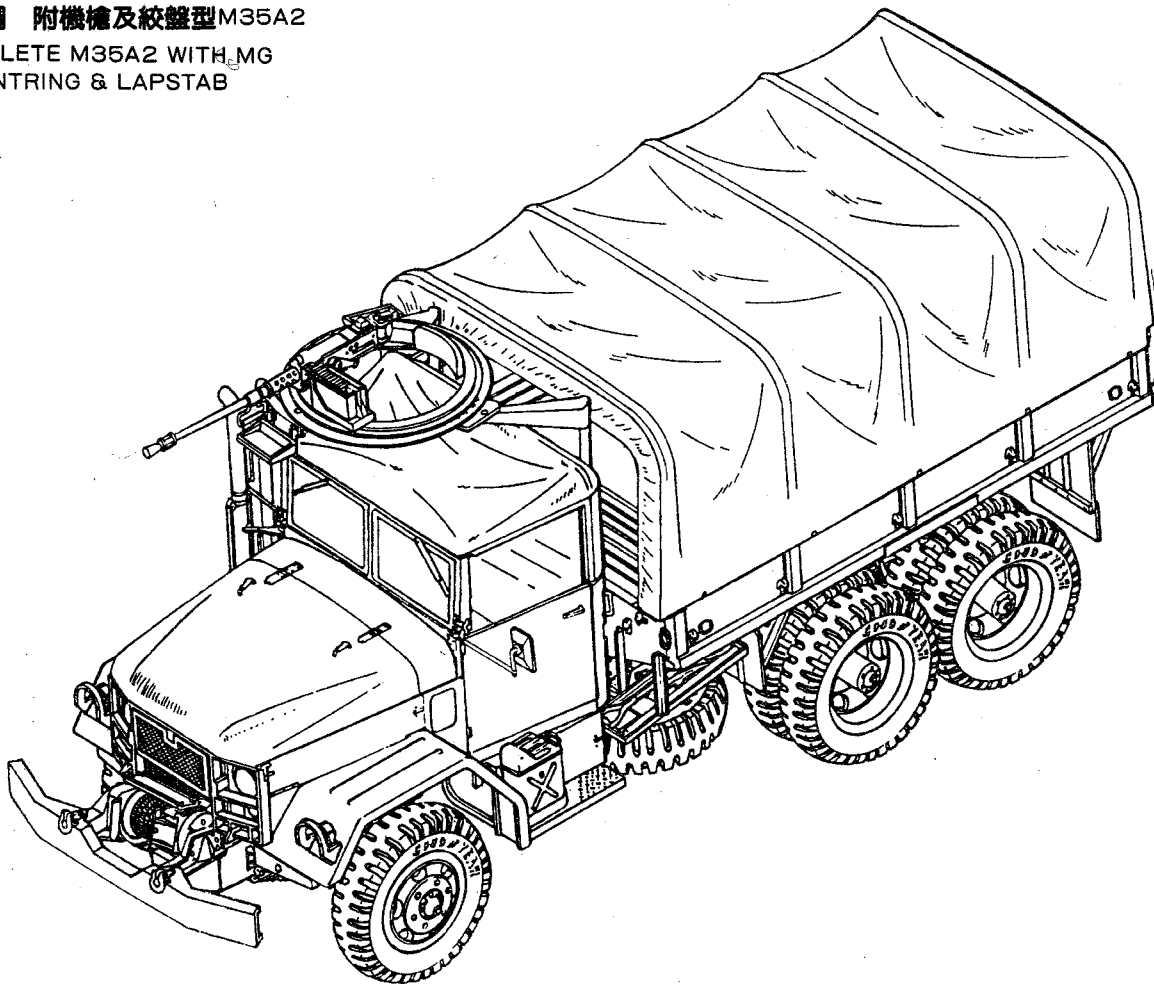

PAINTING & APPLYING DECALS

中華民國陸軍 車體色： Olive drab  
R.O.C. ARMY BODY: Olive drab

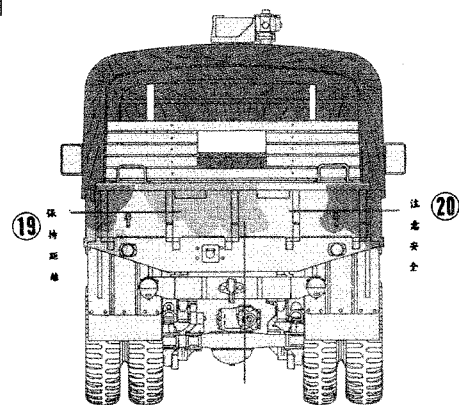
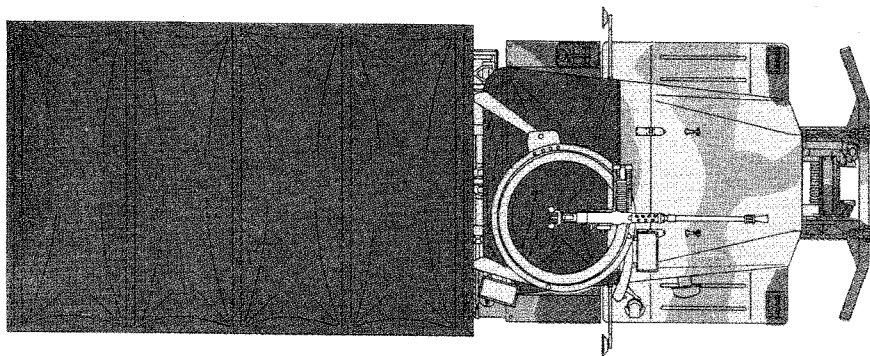

743-21140 12

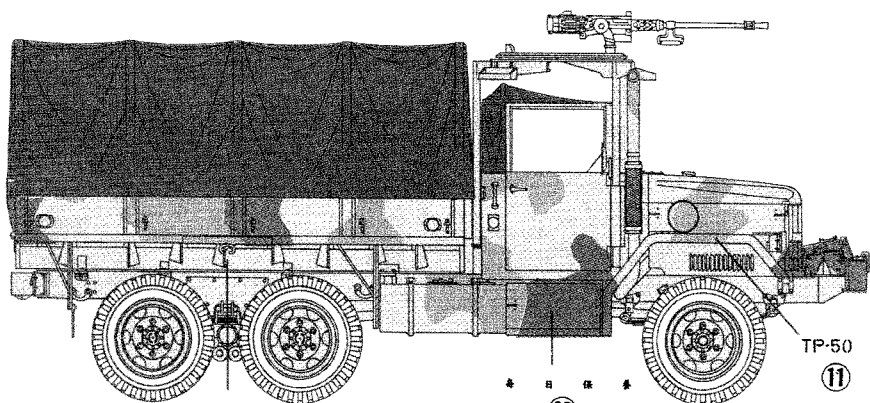

TP-50  
11

22

11

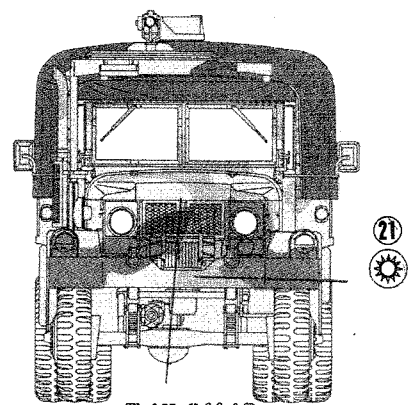

743-21140 12

美國陸軍(沙漠風暴) 車體色：  
U.S. ARMY (DESERT STORM) BODY:

Yellow FS33531

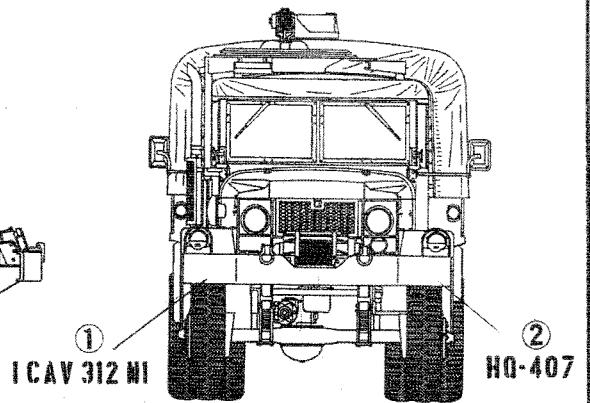
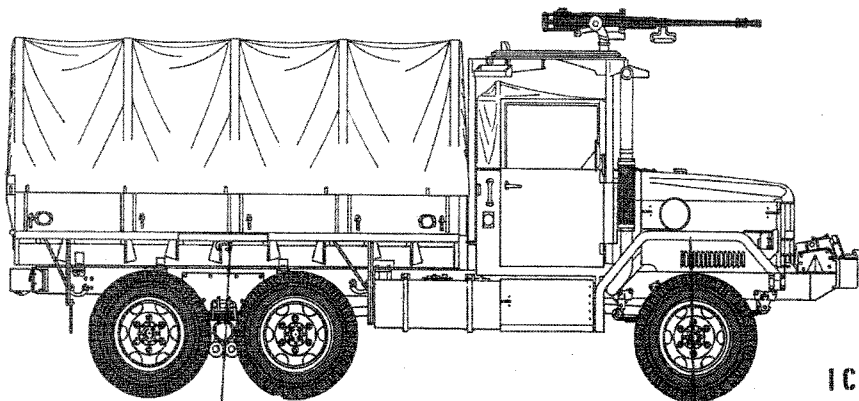
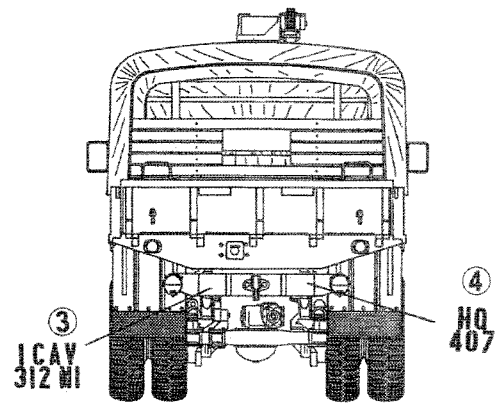
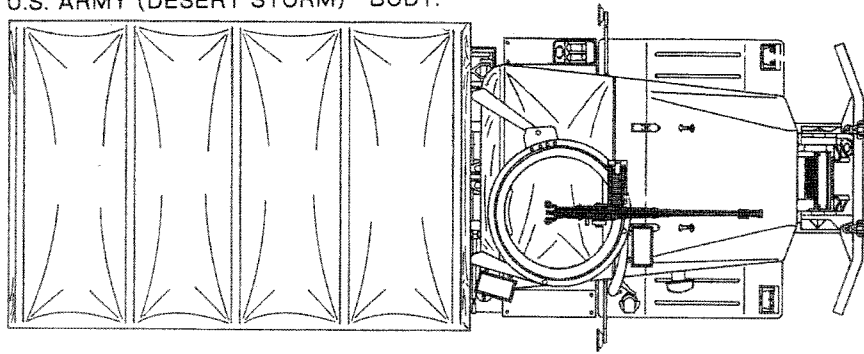

TP-50 ⑩

TP-50 ⑩

美國陸軍  
U.S. ARMY

Tar black RAL 9021

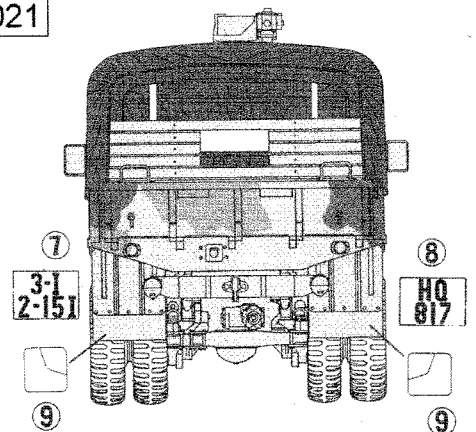
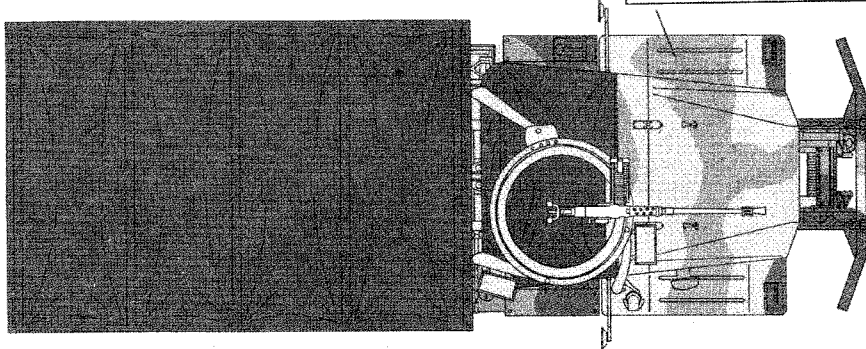

Olive drab

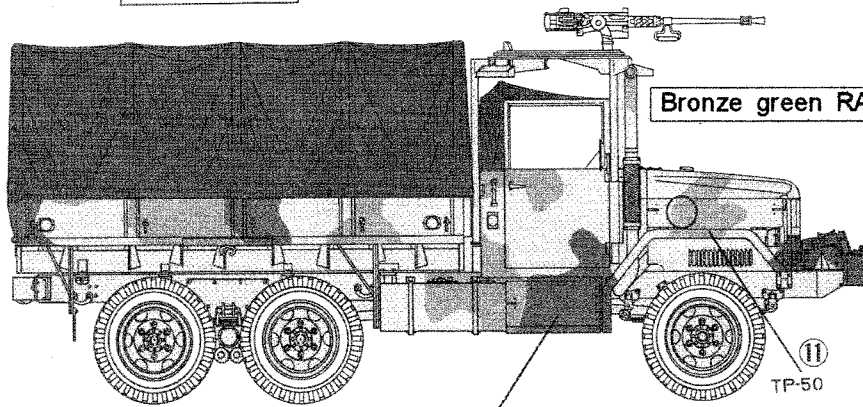

Bronze green RAL 6031

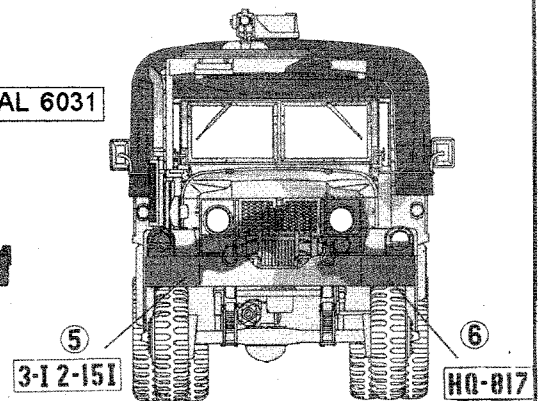

TP-50 ⑪

Leather brown RAL 8027