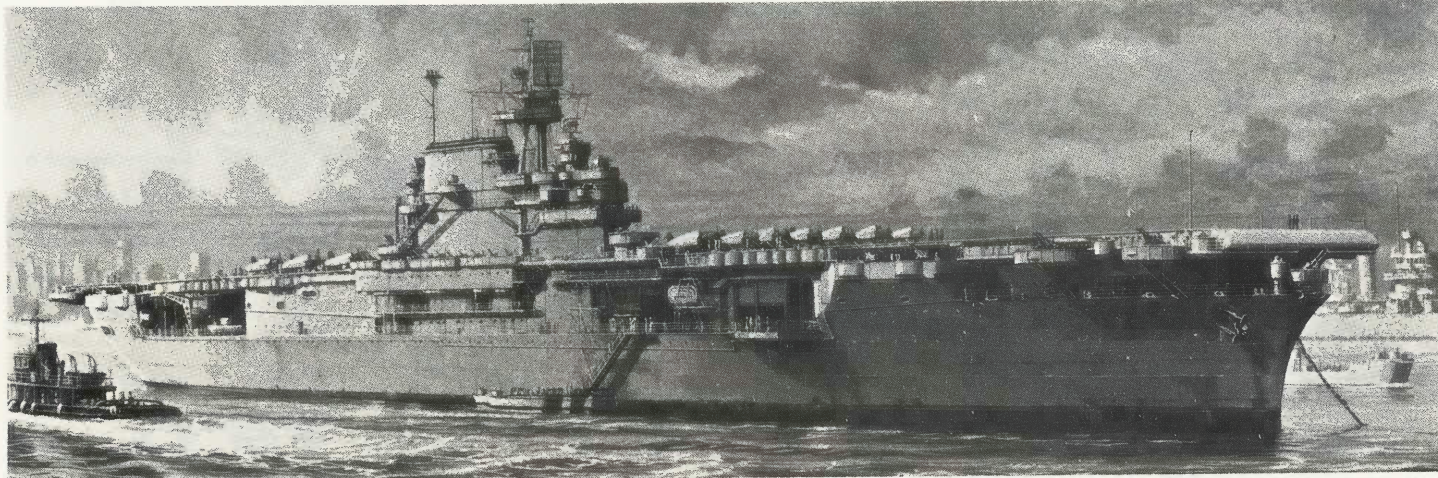

# ENTERPRISE

ウォーターラインシリーズ NO.114

アメリカ海軍 航空母艦 エンタープライズ  
U.S. AIRCRAFT CARRIER

## WATER LINE SERIES

### 《The Aircraft Carrier Enterprise》

The aircraft carrier Enterprise was called "Big E" by the U.S. Navy. Completed in 1938 as the U.S. Navy's sixth carrier by the Newport News Navy Dockyard, the Enterprise was a medium carrier with a displacement of about 19,900 tons and the second Yorktown-type vessel. Although she was able to carry many planes for her size and had fighting capacity comparable to that of large carriers, she was much smaller than the carrier Lexington called "Lady Lex" the carrier Saratoga nicknamed Sara or "Dear Sara" and Essex-class carriers commissioned in service one after another in the latter half of world war II. Still she was called "Big E" in praise of her distinguished services. She participated in 18 of the 22 main naval battles fought in the Pacific War and suffered serious damage for no less than 15 times. But she struggled through the difficulties and continued to fight. The immortal carrier Enterprise thus became the symbol of victory and the boast of the U.S. Navy.

Just before the outbreak of the Pacific war, the 8th Task Force consisting of the carrier Enterprise, three heavy cruisers and nine destroyers under the command of Rear Admiral William F. Halsey ferried the 211th Fighter Squadron of the Marine Corps to Wake Island. They were overtaken by a storm at sea and delayed in returning to Pearl Harbor. On December 8, 1941, they were still at sea away from Pearl Harbor and saved from being attacked by Japanese Vice Admiral Chuichi Nagumo's force. It is reported that Rear Admiral Halsey of dauntless courage stamped with mortification when he knew the Pearl Harbor tragedy. If the carrier Enterprise had been in Pearl Harbor on that day, she would undoubtedly have shared her lot with American battleships such as the Arizona. Thus Destiny saved her life.

Late in January 1942, the Enterprise escorted reinforcement troops to Samoa. On February 1, 1942, her planes carried out an air raid on Kwajalein, Wotje and Maloelap of the Marshall Islands. This was the first air raid on Japanese territory.

At 7:05 a.m. of that day, Lieutenant Commander Hopping in command of the 6th Bombing Squadron dropped the momentous first bomb, but immediately after that he was brought down by Japanese anti-aircraft fire. The Enterprise attacked Wake Island on February 20 and Marcus Island on March 4, 1942. In the first air raid on Japan proper of April 18, 1942, the Enterprise, the then flagship of the 16th Task Force under Rear Admiral Halsey, escorted her consort carrier Hornet fully loaded with B-25 bombers and contributed to the success of the plan. In the Battle of Midway of June 5, 1942, the

Enterprise served as the flagship of the 16th Task Force now under the command of Vice Admiral Raymond A. Spruance and rendered distinguished services. Douglas SBD Dauntlesses of a dive bomber unit from the Enterprise sank the Japanese carriers Kaga, Soryu and Hiryu, which were three of Japan's four main carriers that participated in this naval battle, and also sent the Japanese heavy cruiser Mikuma to the bottom.

Thereafter the war theatre was shifted to the Solomon Islands. As the flagship of the 16th Task Force now under Rear Admiral Thomas C. Kinkaid, the Enterprise took part in the Guadalcanal landing operations on August 7, 1942 and thereafter continued to be active in Solomon waters until the end of May 1943. In the Second Battle of the Solomons fought on August 24, 1942, the Enterprise sank the Japanese carrier Ryuki in cooperation with the U.S. carrier Saratoga, but she received three direct hits and was forced to return to Pearl Harbor for repairs. After completing repairs, the Enterprise participated in the Battle of the South Seas (October 25-26, 1942) where she delivered an unsuccessful attack against the Japanese battleship Kongo. On the contrary, she received three direct hits from the Japanese Junyo unit and had to leave the line of battle again. She underwent temporary repairs in Noumea, east of Australia. Immediately after that, the Third Battle of the Solomons (November 13, 1942) broke out, where she gave a fatal blow to the already damaged Japanese battleship Hiei with her torpedo bombers and, in cooperation with U.S. attack planes from a Guadalcanal base, sank the Japanese heavy cruiser Kinugasa and damaged other cruisers, etc. In the first half of 1944, the Enterprise that had become the flagship of the 1st Group in the 58th Task Force under Vice Admiral Marc A. Mitscher attacked Truk Island, the Caroline Islands, Marcus Island, Wake Island, etc. In June 1944, she became the flagship of the 3rd Group and took part in the offensive against the Mariana Islands, thus inflicting heavy damage on the Japanese.

The 58th Task Force became the 38th Task Force (under Vice Admiral Mitscher) and the Enterprise was incorporated into its 4th Group commanded by Rear Admiral Davidson. Thereafter she participated in successive operations without rest including air raids on the Bonin Islands of August 21-September 2, 1944, air raids on the central part of the Philippines of September 12-14, air raids on Manila of September 20-24, offensive against Palau Island of early October, air raids on Formosa of October 12-14 and air raids on Luzon Island of October 14-16. In the Battle off the Philippines, the Enterprise delivered attacks against three Japanese fleets: On October 24, 1944, she attacked Vice Admiral Shoji Nishimura's fleet and inflicted damage on the battleship Fuso, etc. Then she made attacks on Vice Admiral Takeo Kurita's fleet and, in cooperation with her consorts, sank the battleship Musashi, etc. Also she turned her attacks against Vice Admiral Jisaburo Ozawa's fleet, sinking the carrier Zuicho and inflicting heavy damage on the battleships Ise and Hyuga.

Early in 1945, the Enterprise was incorporated into the 58th Task Force again. She was to show activity as part of its 5th Group whose main role was to conduct night operations. She participated in air raids on the Tokyo-Yokohama area made on February 16-17 and 23, and also in the operations against Iwo Jima Island. During air raids on the southern part of Kyushu which were a prelude to the invasion of Okinawa Island, the Enterprise was attacked by

Okinawa and supported U.S. landing forces on the island. On April 7 she delivered attacks against a Japanese special attack squadron containing the battleship Yamato. On April 11, the Enterprise was body-crashed by two special attack planes when she was making air raids on Japanese ships in the Inland Sea of Japan. She sustained damage to her fuel tanks, generators, etc. and was forced to return to Ulithi for repairs.

After completing repairs in about three weeks, the Enterprise joined the line of battle again and, as the flagship of Vice Admiral Mitscher's Task Force, made air raids on special attack plane bases in the southern part of Kyushu. Unfortunately, the Enterprise was to be attacked by Kamikaze suicide planes again. On May 14, 1945, about 30 Japanese planes made suicide attacks against Mitscher's Task Force which was sailing south of Kyushu. One of them bored relentlessly in toward the Enterprise through a storm of anti-aircraft fire, skimmed her flight deck from the stern to the stem as if it had been trying to make a deck landing, and crashed into the sea ahead. The Kamikaze's bomb hit the Enterprise near the fore elevator causing great damage to her. The elevator was blown off more than 100 metres high up in the air and the flight deck was swollen. The Enterprise moved Vice Admiral Mitscher's flag to the carrier Randolph and returned to her home port Bremerton for repairs, where she knew the end of the war.

During the war, the Enterprise moved around in the Pacific Ocean for a total of no less than 275,000 miles and rendered the most distinguished services by sinking 71 vessels, damaging 192 vessels and shooting down 911 planes. In 1960, she was broken up and ended her brilliant life. Her name "Enterprise" was inherited by the world's first atomic carrier.

《The Enterprise and Great Commanders》

#### ● William F. Halsey



William F. Halsey of dauntless courage who was known by the nickname of "Bull" fought on board the carrier Enterprise as the commander of the 6th and 16th Task Forces. Later he became the commander of the Third Fleet and distinguished himself in the Battle off the Philippines, etc. by using his 38th Task Force containing the Enterprise. His force was called "Halsey Typhoon." He was good at strong tactics referred to as "Bull Dash."

#### ● Raymond A. Spruance



He acted with the Enterprise as the commander of the heavy-cruiser squadron in the 6th and 16th Task Forces. In the Battle of Midway, he commanded the 16th Task Force. Later he became the commander of the Fifth Fleet and distinguished himself in the Mariana and Okinawa operations by using his 58th Task Force containing the Enterprise.

#### ● Marc A. Mitscher



He served as the captain of the carrier Hornet in the first air raid on Tokyo. Later he became the commander of the 58th and 38th Task Forces and distin-

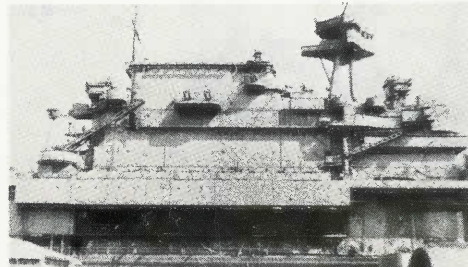

was the first air raid on Japanese territory. At 7 05 a.m. of that day, Lieutenant Commander Hopping in command of the 6th Bombing Squadron dropped the momentous first bomb, but immediately after that he was brought down by Japanese anti aircraft fire. The Enterprise attacked Wake Island on February 20 and Marcus Island on March 4, 1942. In the first air raid on Japan proper of April 18, 1942, the Enterprise, the then flagship of the 16th Task Force under Rear Admiral Halsey, escorted her consort carrier Hornet fully loaded with B-25 bombers and contributed to the success of the plan. In the Battle of Midway of June 5, 1942, the

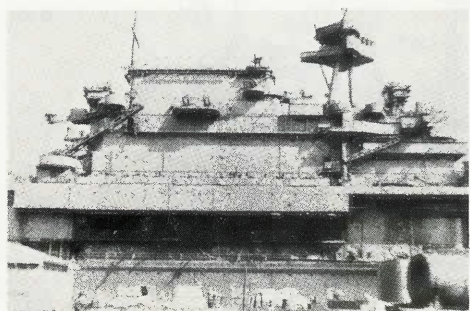

Photo from the National Archives, Washington D.C.

raids on the Bonin Islands of August 21 September 2, 1944, air raids on the central part of the Philippines of September 12-14, air raids on Manila of September 20-24, offensive against Palau Island of early October, air raids on Formosa of October 12-14 and air raids on Luzon Island of October 14-16. In the Battle off the Philippines, the Enterprise delivered attacks against three Japanese fleets: On October 24, 1944, she attacked Vice Admiral Shoji Nishimura's fleet and inflicted damage on the battleship Fuso, etc. Then she made attacks on Vice Admiral Takeo Kurita's fleet and, in cooperation with her consorts, sank the battleship Musashi etc. Also she turned her attacks against Vice Admiral Jisaburo Ozawa's fleet, sinking the carrier Zuiho and inflicting heavy damage on the battleships Ise and Hyuga.

Early in 1945, the Enterprise was incorporated into the 58th Task Force again. She was to show activity as part of its 5th Group whose main role was to conduct night operations. She participated in air raids on the Tokyo-Yokohama area made on February 16-17 and 23, and also in the operations against Iwo Jima Island. During air raids on the southern part of Kyushu which were a prelude to the invasion of Okinawa Island, the Enterprise was attacked by Japanese suicide planes on the first (March 18) and third (March 20) days but the damage was not serious. Then she attacked Japanese air bases in

Third Fleet and distinguished himself in the Battle off the Philippines, etc. by using his 38th Task Force containing the Enterprise. His force was called "Halsey Typhoon". He was good at strong tactics referred to as "Bull Dash".

● Raymond A. Spruance



He acted with the Enterprise as the commander of the heavy-cruiser squadron in the 6th and 16th Task Forces. In the Battle of Midway, he commanded the 16th Task Force. Later he became the commander of the Fifth Fleet and distinguished himself in the Mariana and Okinawa operations by using his 58th Task Force containing the Enterprise.

● Marc A. Mitscher



He served as the captain of the carrier Hornet in the first air raid on Tokyo. Later he became the commander of the 58th and 38th Task Forces and distinguished himself in the Mariana, Philippine and Okinawa operations, etc.

(Painting and Marking of Carrier Aircraft)

After June 1944 all surfaces were painted in Navy Blue.

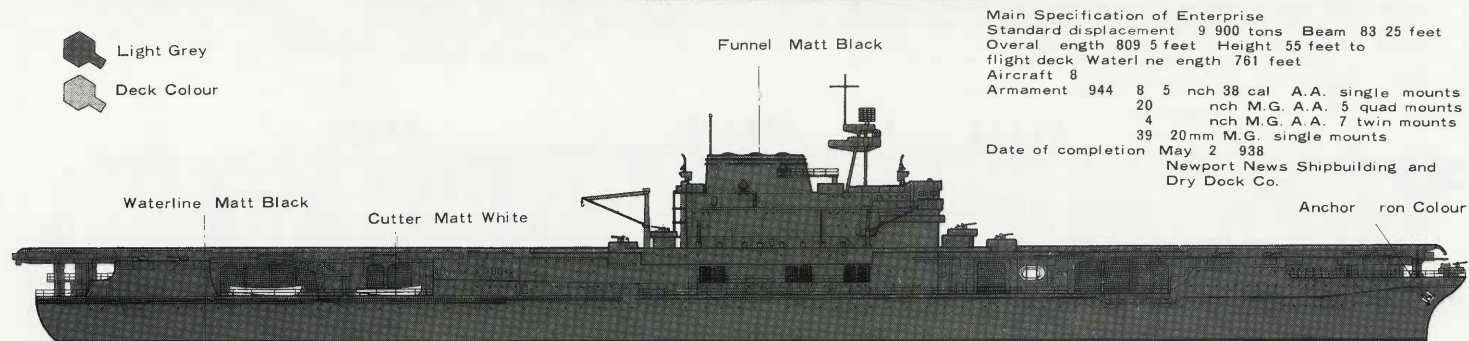
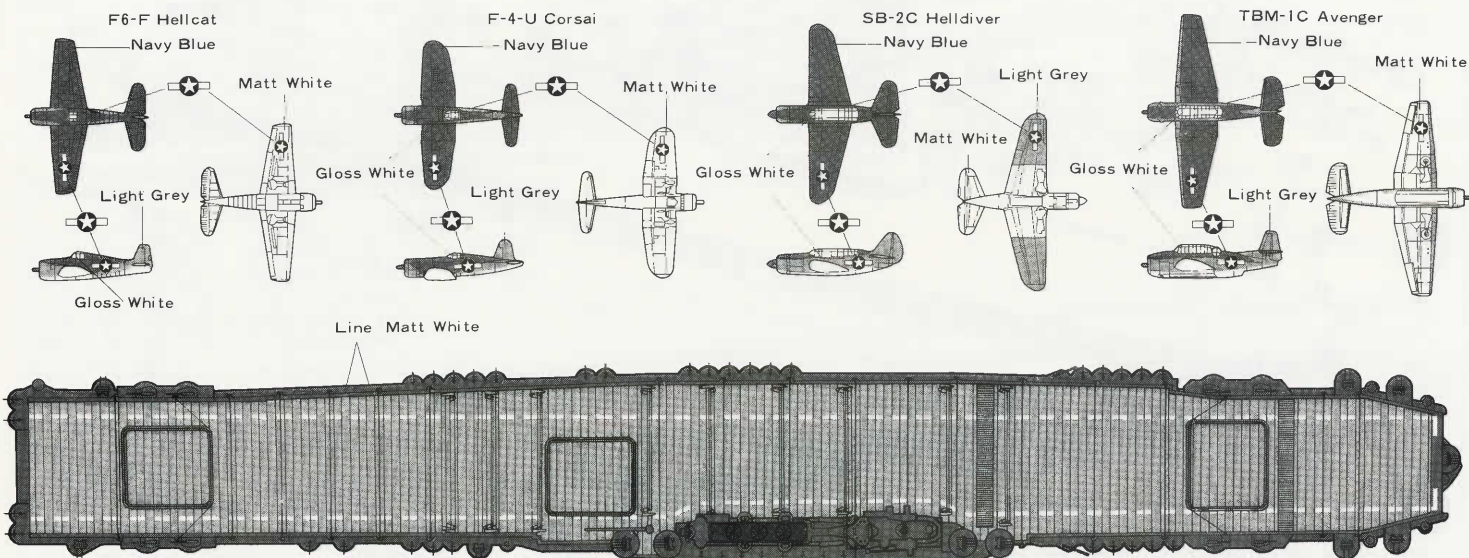

Main Specification of Enterprise  
 Standard displacement 9 900 tons Beam 83 25 feet  
 Overall length 809 5 feet Height 55 feet to flight deck Waterline length 761 feet  
 Aircraft 8  
 Armament 944 8 5 inch 38 cal A.A. single mounts  
 20 inch M.G. A.A. 5 quad mounts  
 4 inch M.G. A.A. 7 twin mounts  
 39 20mm M.G. single mounts  
 Date of completion May 2 1938  
 Newport News Shipbuilding and Dry Dock Co.

# ENTERPRISE エンタープライズ

<Please read this before commencing assembly>

★Do not break parts away from sprue, but cut off carefully with a pair of pliers. ★Apply cement to both parts to be joined. ★Use a pair of tweezers in assembling small parts.



**TAMIYA**  
TAMIYA PLASTIC MODEL CO.  
626, OSHIKA, SHIZUOKA-CITY, JAPAN

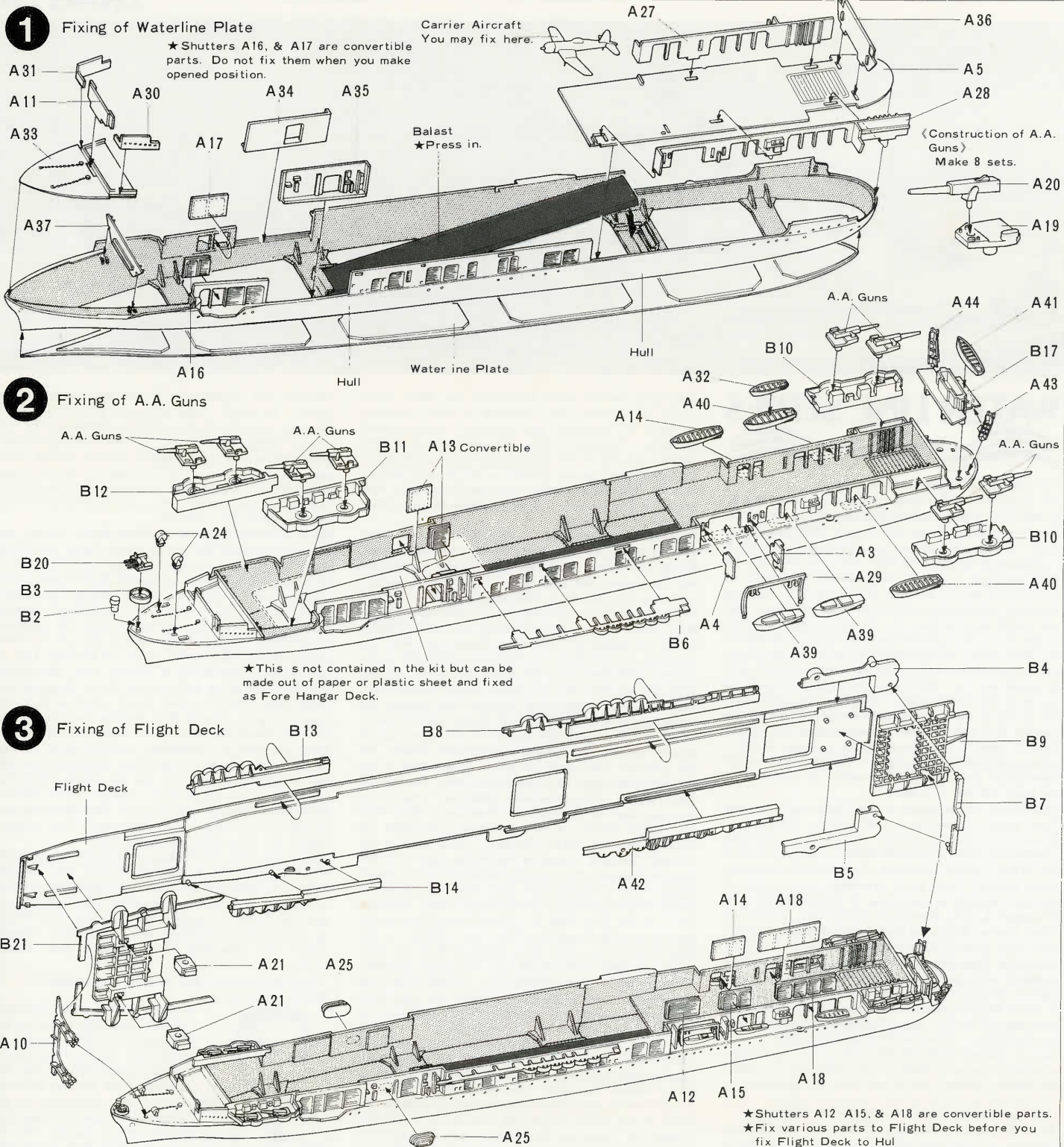



A25

★Shutters A12, A15, & A18 are convertible parts.  
★Fix various parts to Flight Deck before you fix Flight Deck to Hull

## 4 Construction of Bridge

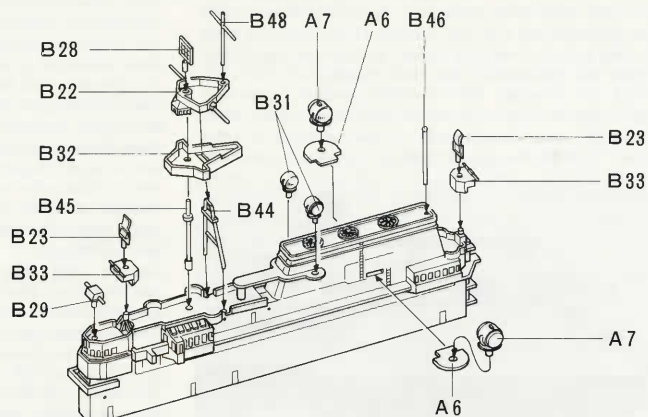
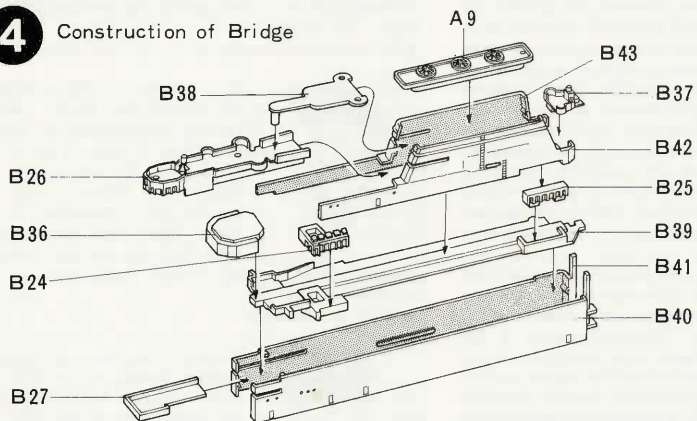

## 5 Fixing of Bridge

《Fixing of Life Boats》

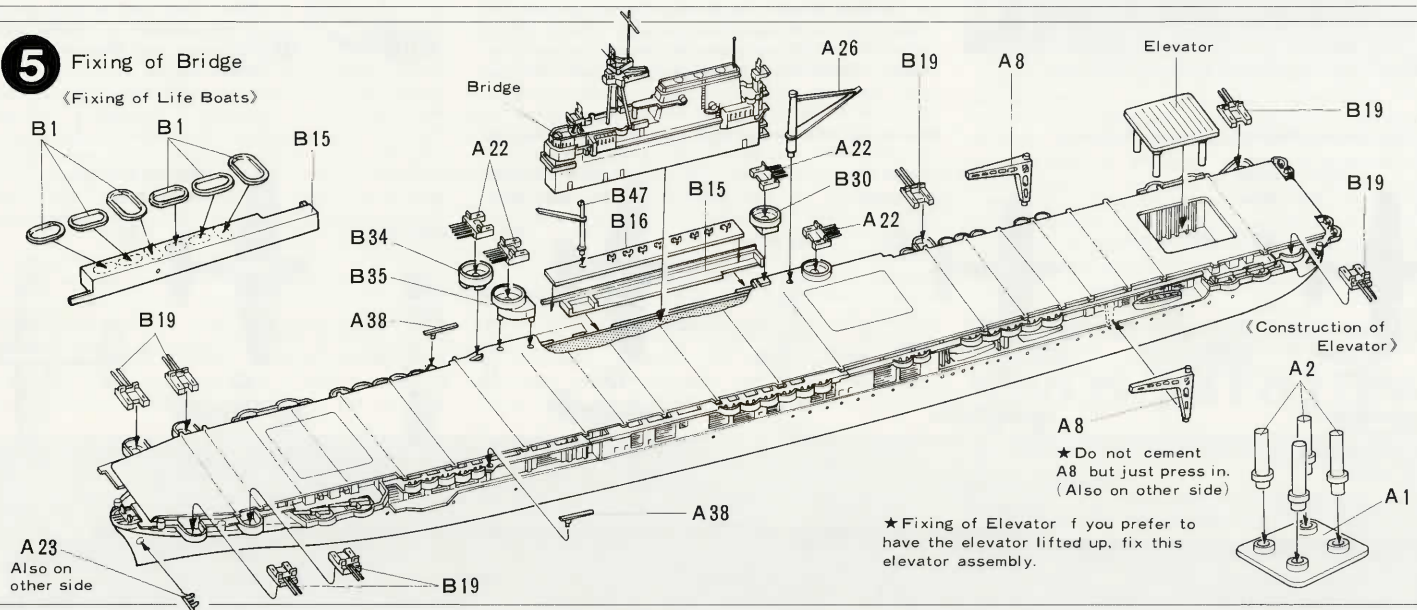

## 6 Fixing of Machine Guns & Carrier Aircrafts

★Use enamel wires or parts of A45 contained in the kit as machine gun barrels. Cut them in lengths shown in the scale below. In all 39 pieces are needed. They should be careful y fixed to respective positions indicated by the arrows ↓ with cement.

★Fix Carrier Aircrafts after painting. From bows, fix them in the order of the fighters, next the bombers.

3mm long

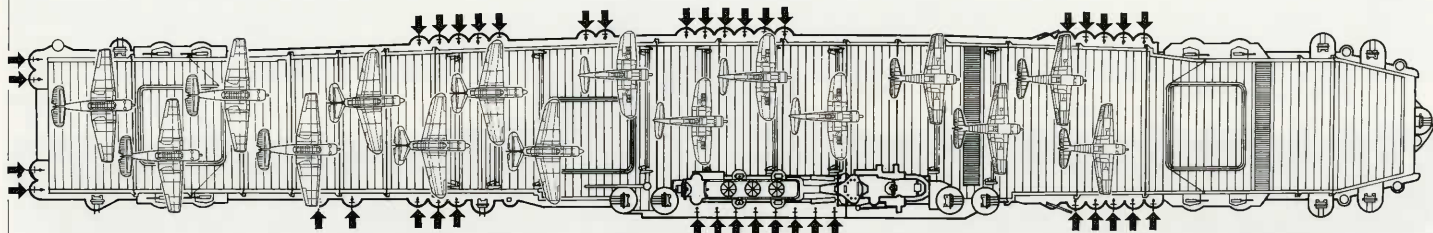
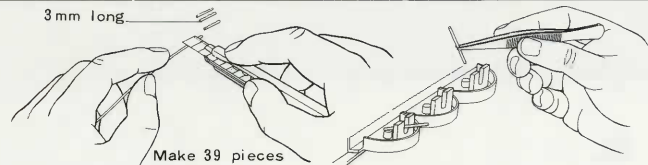

SCALE Use when you cut wire for M. G. gun barrel

PRINTED IN JAPAN