

PROFILE SERIES

mpe

MODEL PRODUCTS
126 GROESBECK HIGHWAY
MOUNT CLEMENS, MICHIGAN
48043

PLEASE READ THIS FIRST

Before you begin, read the instructions very carefully. Study the illustrations and become familiar with the pieces before you start assembly of your model. Following the procedures given, test fit all parts before cementing, this way you will become acquainted with the location of parts when it comes time to use cement.

The highest quality styrene goes into the making of each MPC model. Only paint and cement made for styrene should be used. Before test fitting parts, trim off excess "flash". To join parts, use cement sparingly. Apply cement to very small parts with a toothpick. For removing parts from the "runners" it is best to use your modelers knife, do not attempt to twist them off.

When painting your model follow the painting tips in each step. It is best to paint the very small parts while they are still on the runners. For realism use flat colors and use them carefully.

You should have no trouble assembling your kit if the instructions are followed properly.

WATCH FOR PAINTING NOTES

⑤ ASSEMBLY NUMBERS

5 PART NUMBERS

A-26 Invader

2003

Entering service late in World War II, designated then as the A.26, the Invader was America's fastest bomber, proving to be especially deadly in attack missions, it performed brilliantly in knocking out D-Day enemy ground installations, supporting troop advances and securing the skies from German counter-attacks. It also participated in spectacular actions against the Japanese in the Pacific. When the Korean War began, Invaders were immediately pressed into service. They were assigned primarily, and very successfully on night raids against Communist supply lines and on close ground support missions. Despite frantic efforts by the jet-equipped Communist air force to keep supply lines open, the Invaders exacted a tremendous toll of enemy ground equipment, installations and supplies. Powered by two Pratt & Whitney R.2800-27 eighteen cylinder radial engines, giving a maximum speed of 355 mph. Armament varied according to role. Wing span 70 ft. and length 49 ft. 11 in.



Paint crew members as noted (flat colors):

Jacket BROWN
Pants BLUE GREY
Helmet BROWN
Goggles BLACK (lenses BLUE)
Scarf WHITE
Hands BLACK (Gloves)
Face FLESH
Boots BROWN

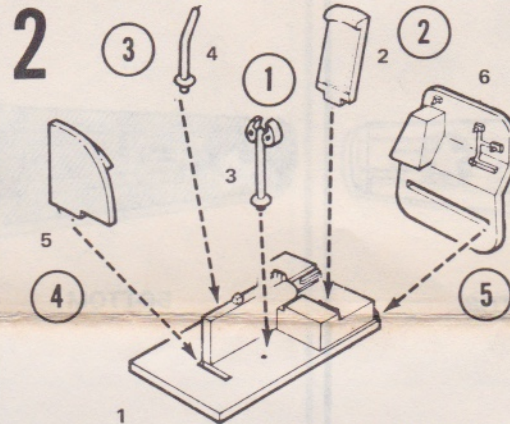

Paint parts YELLOW-GREEN

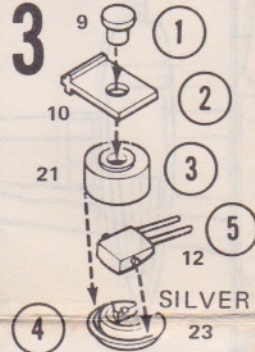

Use for A26 Invader
Korean Conflict
Paint FLAT BLACK

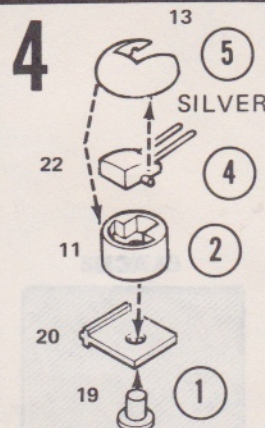

③ Use for A26 Invader
Paint FLAT BLACK

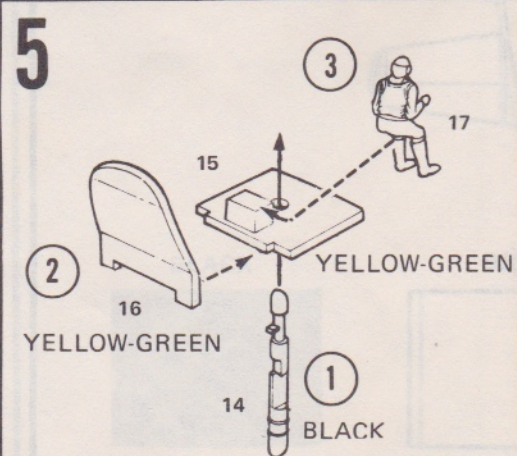

6

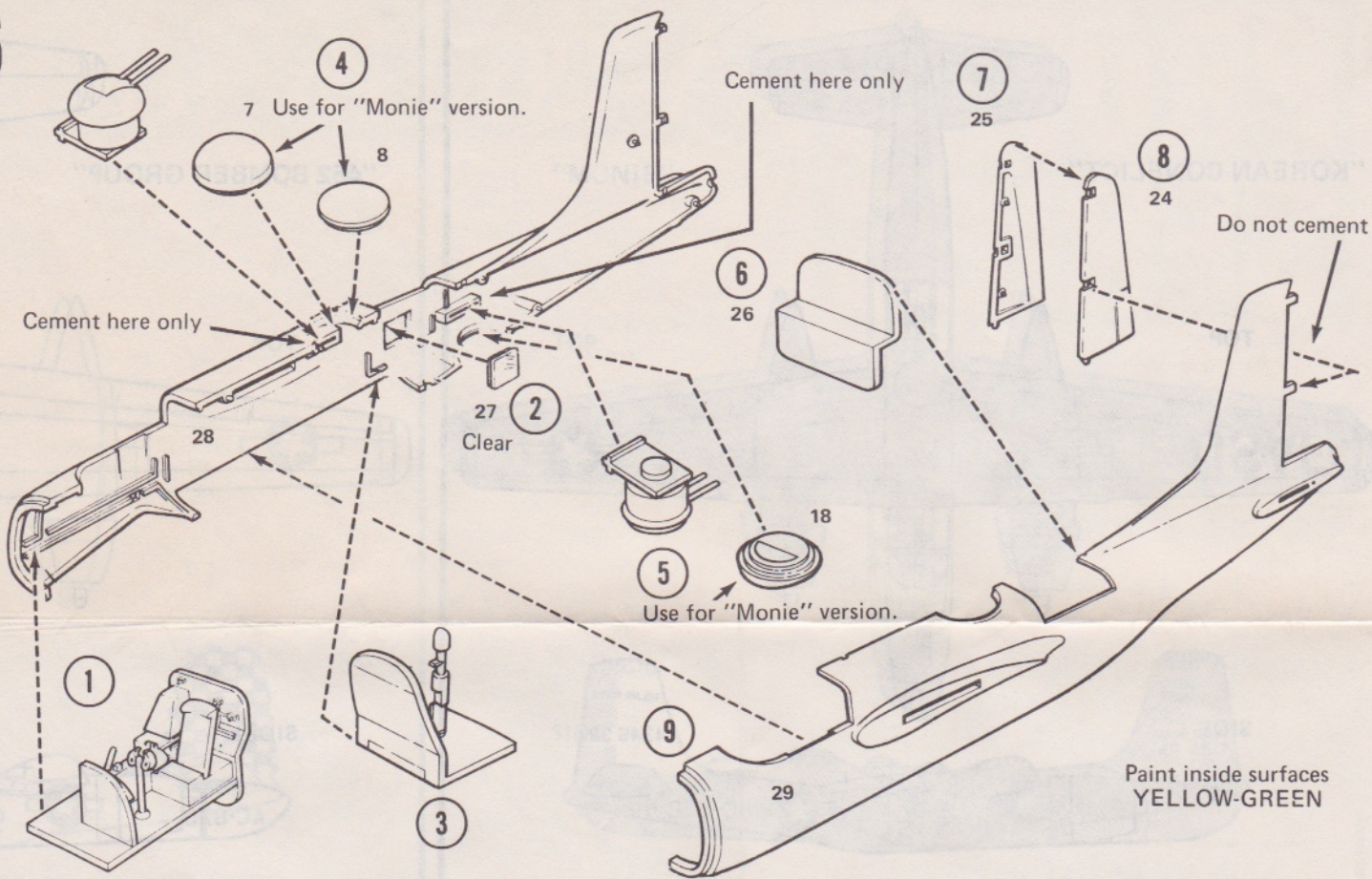

7

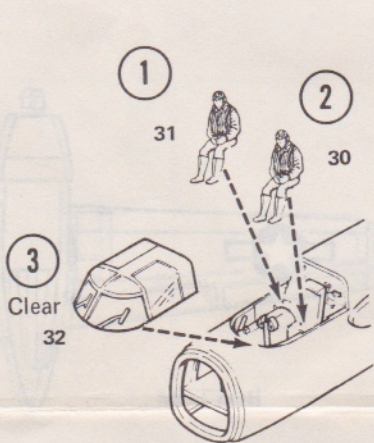

8

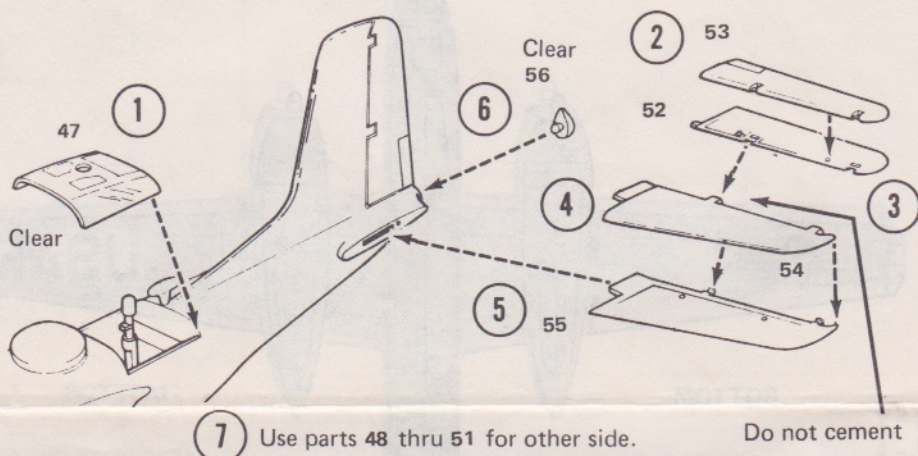

9

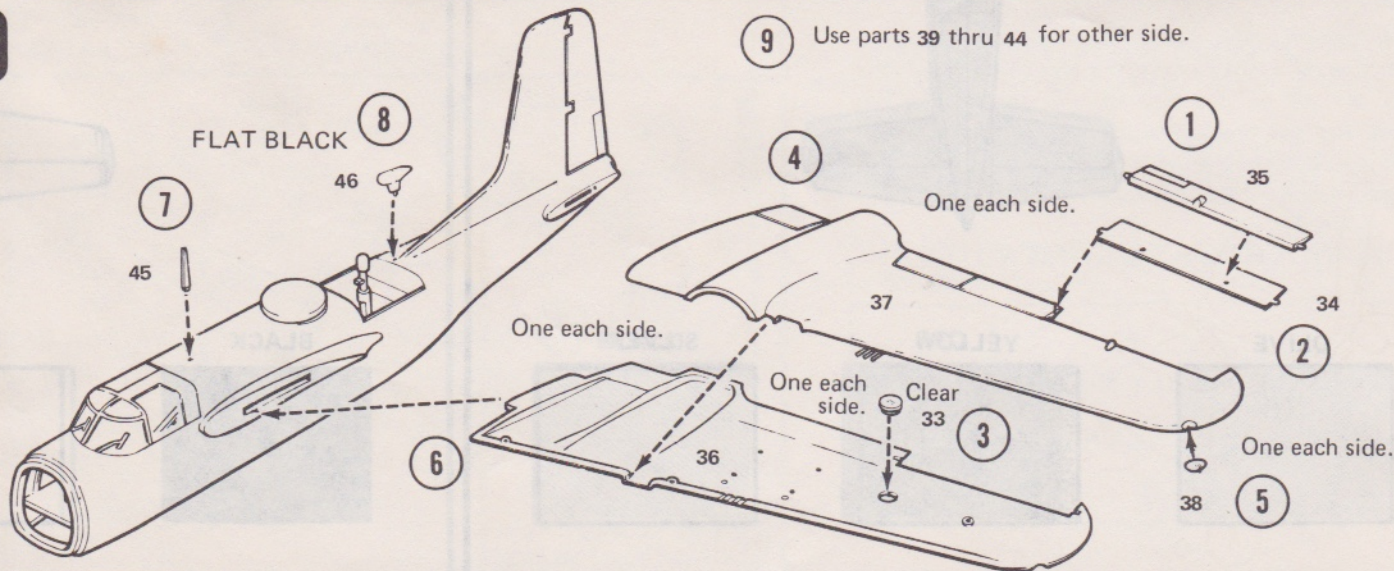

14

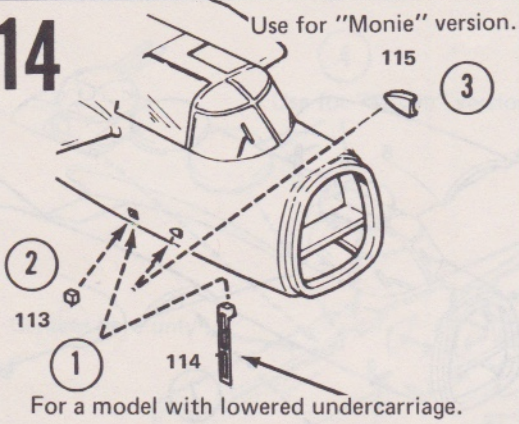

15

CLOSED HATCH OPTIONAL

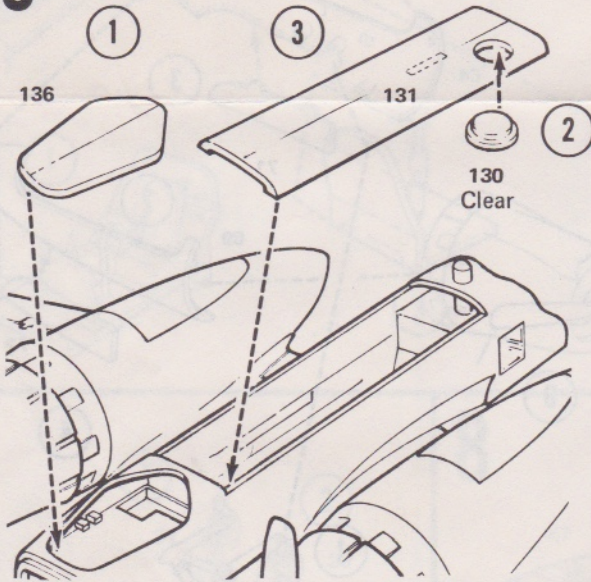

11

Use parts 123 thru 129 for other side.

Use 134 for other side.

OPEN HATCH

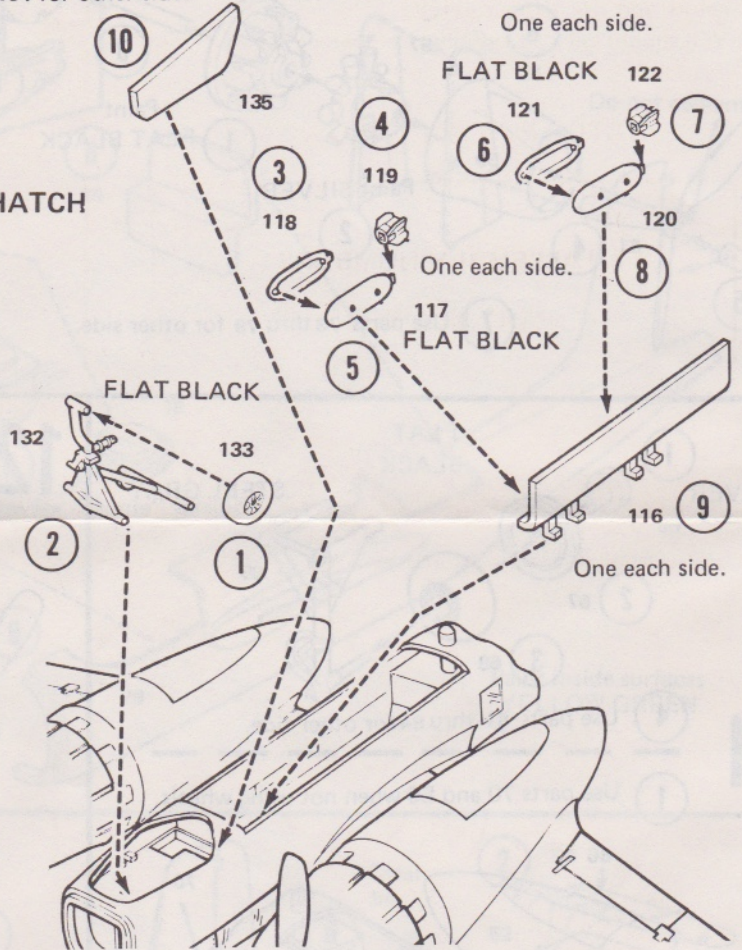

16

YELLOW-GREEN

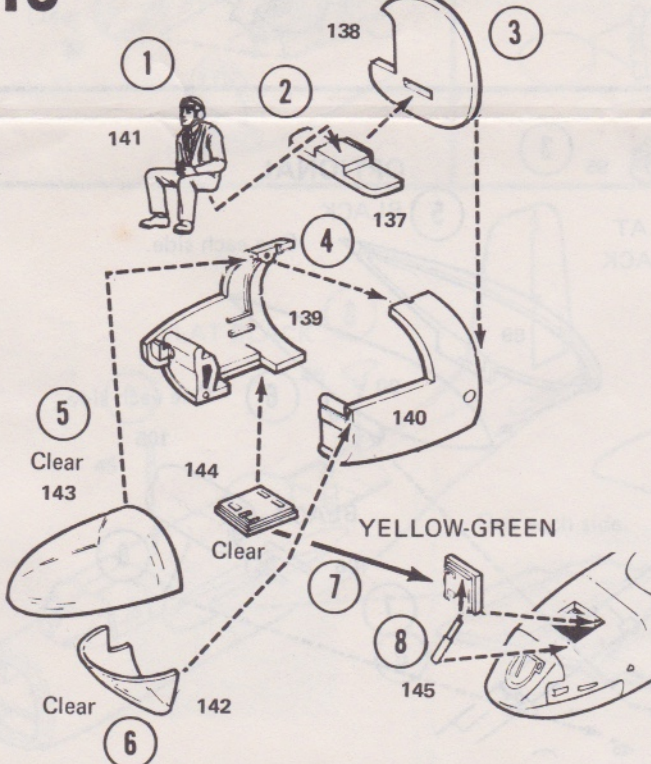

17

FLAT BLACK

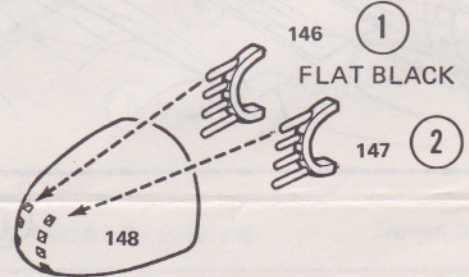

For aircraft standing on lowered undercarriage a suitable weight, such as Plasticine or clay should be added inside nose before cementing.

Use for "Monie" version.
Use for 452 Bomber.

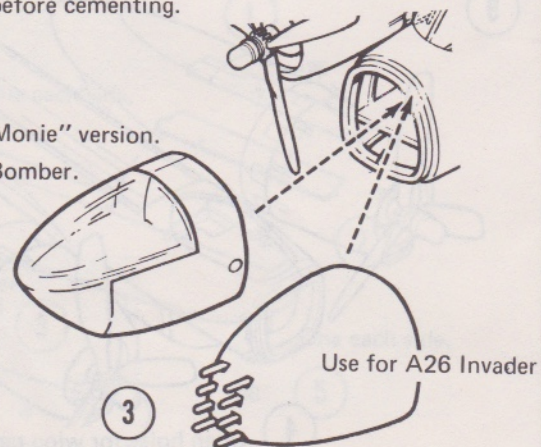

"KOREAN CONFLICT"

TOP

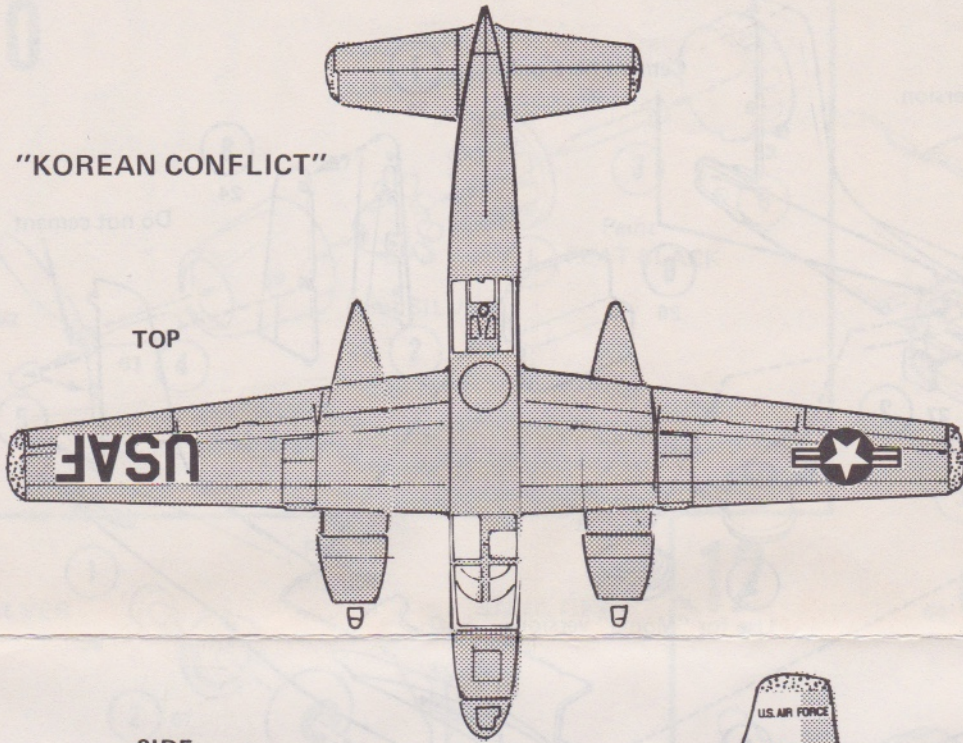

SIDE

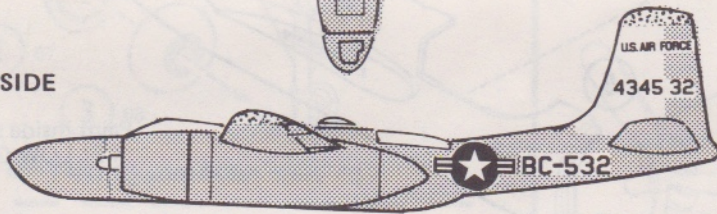

BOTTOM

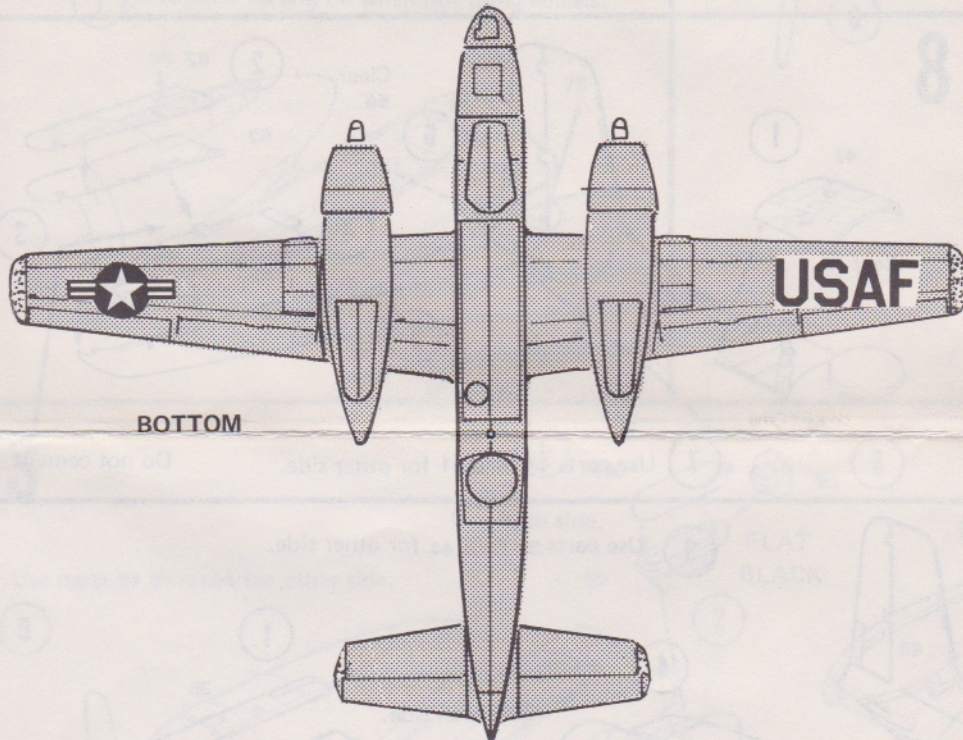

OLIVE



YELLOW

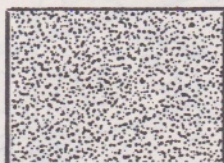

SILVER

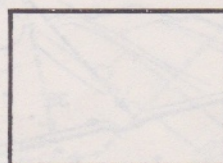

"452 BOMBER GROUP"

TOP

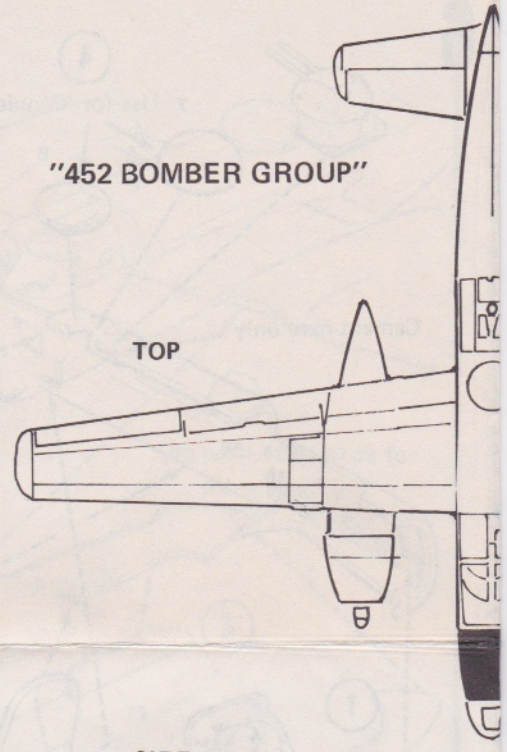

SIDE

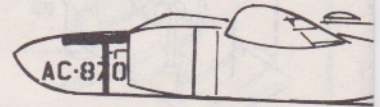

BOTTOM

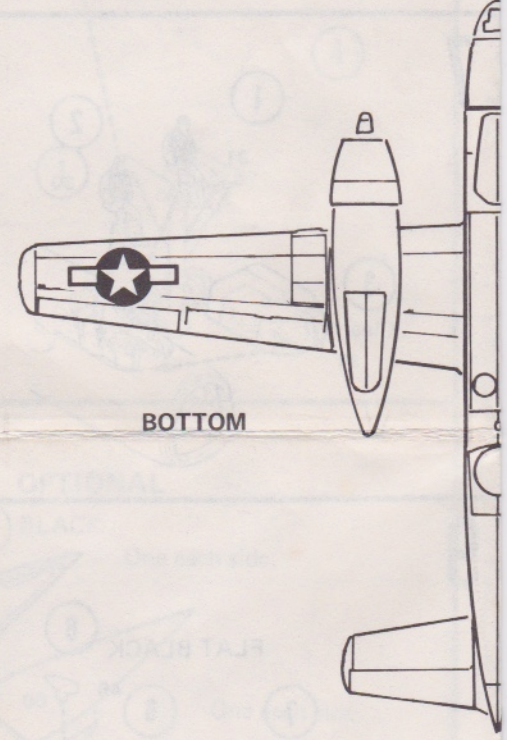

BLACK



SILV

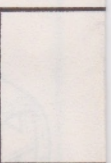

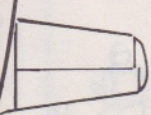
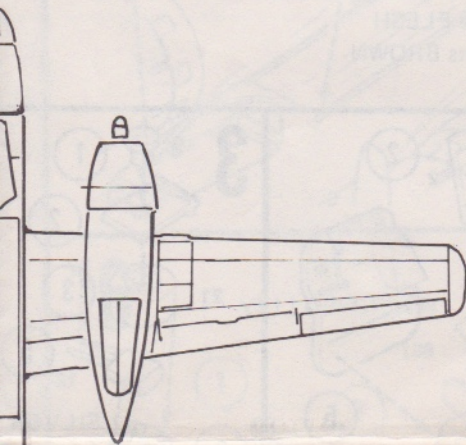
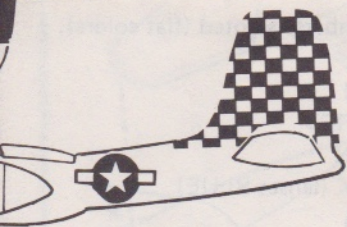
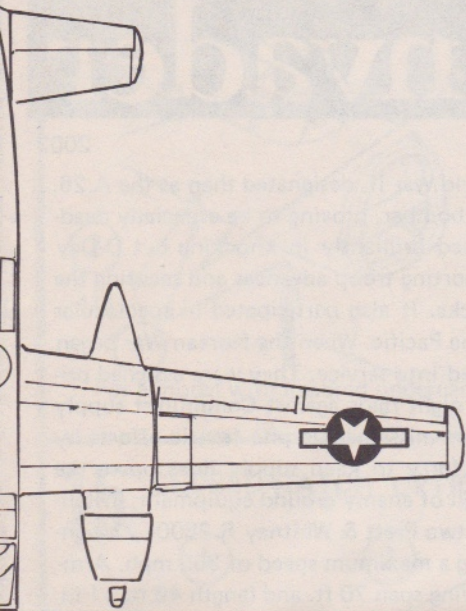

VER

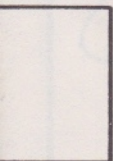

"MONIE"

TOP

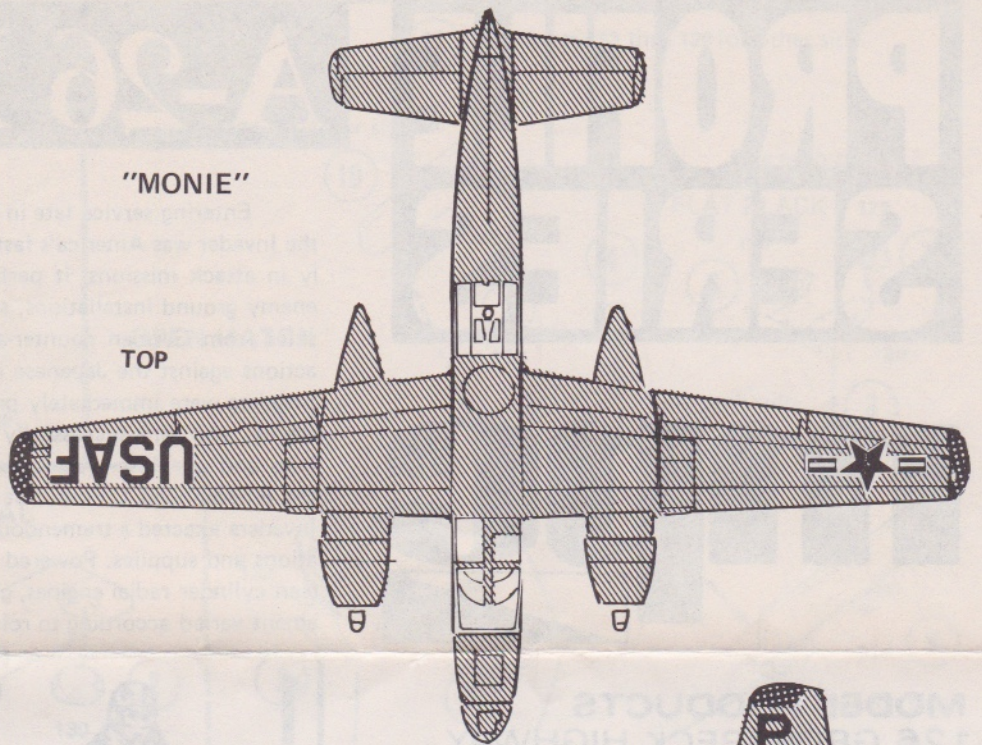

SIDE

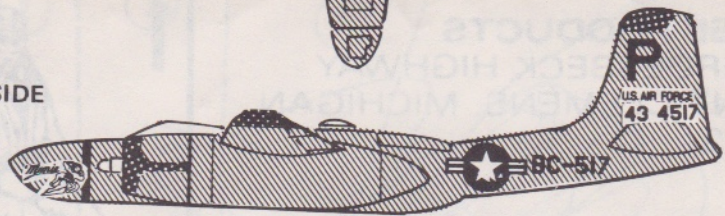

BOTTOM

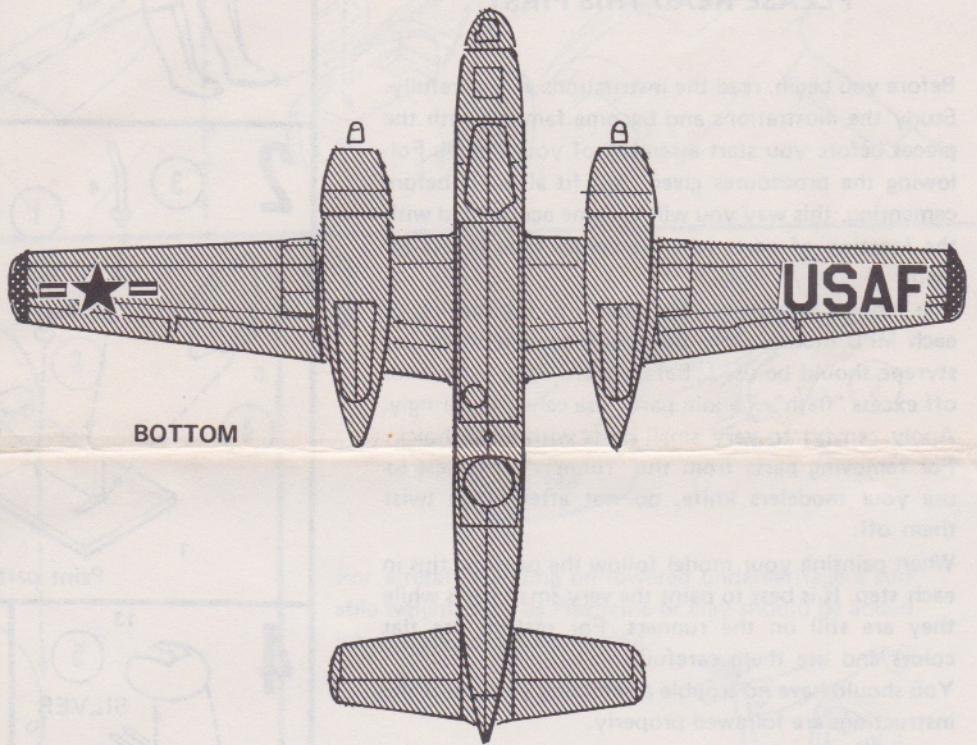

BLACK



RED

