

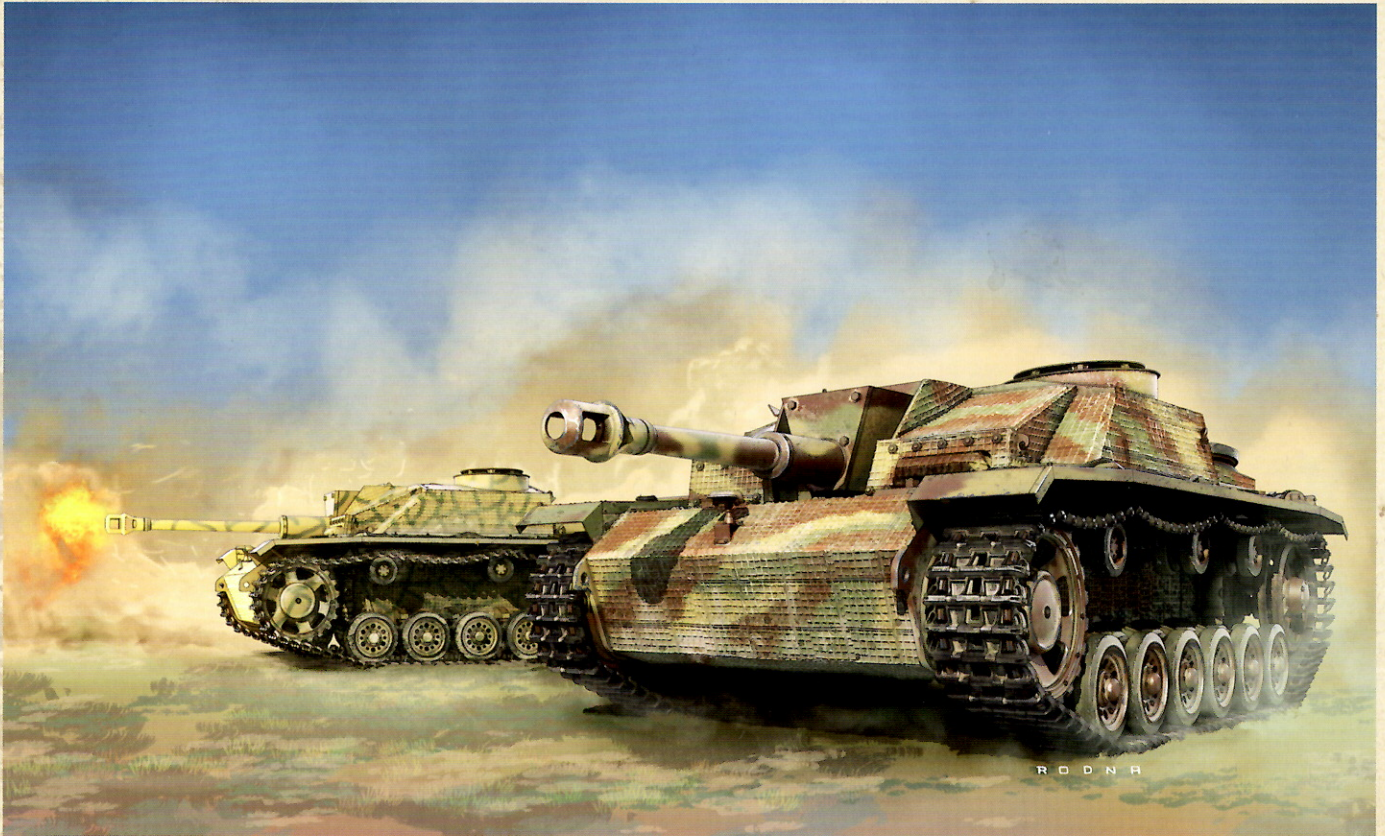

10,5cm StuH42 / 7,5cm StuG III Ausf.G with Zimmerit

2 in 1



Vor dem Zusammenbau lesen!

DW35021

組立ての注意

- ・接着剤や塗料は火の近くで使わないでください。使う時はときどき窓を開けて換気は気をつけましょう。
 - ・部品をランナーから切り離す時は模型用ハサミ等を使い、余分な部分はカッターやヤスリ等で仕上げてください。
 - ・組立図のサインマークは下の説明をごらんください。
- 《注意》
- ・勿於近火處使用膠水或油漆・並打開窗戶保持空氣流通。
 - ・自膠架中取出部件時・應用模型專用剪・並用界刀或小銼除去多餘的膠料。
 - ・各圖型的含意可參考本欄以下的說明。

ZUR BEACHTUNG

- ・ Kleber und Farbe nicht nahe von offenem Feuer verwenden und das Fenster von Zeit zu Zeit zur Belüftung öffnen.
- ・ Zum Abschneiden der Teile vom Verbundstück eine Modellierschere verwenden und die überstehenden Plastikteile mit einem Messer oder einer Feile beseitigen.
- ・ Die Bedeutung der Symbols finden Sie unten in dieser Spalte.

CAUTION

- ・ When you use glue or paint, do not use near a naked flame, and use in a well-ventilated room.
- ・ When you take parts off the runner frame, use modeling scissors and trim excess plastic with a cutter or a file.
- ・ See below for the meaning of symbols.

ATTENTION

- ・ Ne pas utiliser de colle ou de peinture a proximité d'une flamme nue, et aérer la pièce de temps en temps.
 - ・ Pour retirer les pièces hors du cadre, utiliser des ciseaux spéciaux pour maquette le plastique en excès avec un cutter ou une lime.
 - ・ Voir la fin de cette colonne pour la signification des symboles
- ATTENZIONE**
- ・ Non usare colla o vernice vicino a fiamme esposte, e aprire le finestre di tanto in tanto per cambiare l'aria.
 - ・ Quando si staccano parti del carrello, usare forbici da modellismo e eliminare la plastica in eccesso con un coltello o una lima.
 - ・ Vedere in fondo a questa colonna per il significato dei simboli.

x2 2 つおつてください
MAKE 2PCS
2 TEILE FERTIGEN
EFFECTUER 2 PIECES
FARE DUE PEZZI
TEE 2 KPL
GÖR 2 ST
製作二組

切り取ってください
REMOVE
ENTFERNEN
RETRIERER
SEPARARE
POIŠTA
AVLÄGSNA
除去

接着しないでください
DO NOT CEMENT
NICHT KLEBEN
NE PAS COLLER
NON INCOLLARE
EILIJMÄÄ
LIMMAEJ
不用貼合

テカールを付けてください
APPLY DECAL
HIER ABZIEHBILD
APPLIQUER DECALCOMANIE
APPLICARE DECALCOMANIE
ASETA SIIRTOKUVÄ
APPLICERA DECALEN
貼上水印紙

穴をうめてください
FILL HOLE
SCHLIESSEN
BOUCHER LE TROU
FORD PIENO
TAYTÄ REIKA
FYLL HÄLET
填孔填平

接着剤が乾くまで2-3分待ちます。
PLEASE WAIT FOR A FEW MINUTES UNTIL DRY
ENGIG MINUTEN WARTEN BIS DER KLEBSTOFF GETROCKNET IST
ASPETTARE ALCUNI MINUTI FINCHE LA COLLA SI E ASCIUGATA
VEUILLEZ PATIENTER QUELQUES AUQUVAU SECHAGE
VÄNTÄ NÄKÄMÄ MINUUTTI KUUNES KUUVAINUT
ODOTA NÄKÄMÄ MINUUTTI KUUNES KUUVAINUT
稍候數分鐘 直至接著劑乾固

注意してください
BE CAREFUL
HIER VORSICHT
USARE ATTENZIONE
VAROVASTI
FORIKTIGT
小心留意

穴をめてください
OPEN HOLE
OFFENEN
FAIRE UN TROU
FORO APERTO
AVAA REIKA
ÖPPNÄ HALET
鑽孔

接着してください
CEMENT TOGETHER
ZUSAMMENKLEBEN
COLLER ENSEMBLE
INCOLLARE INSIEME
LIIMAA YHTEEN
LIMMA IHOP
用膠貼合

折り曲げてください
BEND
BITTE BIEGEN
PLIER S'IL VOUS PLAÎT
PIEGARE
TAITA
BOCKA
屈曲

どちらかを選んでください
OPTIONAL
NACH BELIEBEN
FACULTATIF
FACOLTATIVO
VALINNANVARAINEN
VALBAR
可以選擇採用

瞬間接着剤 (金属用)
INSTANT GLUE FOR METAL
METALLKIEBER
COLLA A METAL INSTANTANEE
COLLA Istantanea per metallo
PIKALIMAA METALLIOSIA VARTEN
SNABBIM FOR METALLDELAR
金屬用速乾膠

		COLOR	RAL	Tamiya	Mr Hobby H-Series	AMMO of MIG	Vallejo	Humbrol	Mission Models
	A	Black	9005	XF1	H12	0046	71.057	33	MMP-047
	B	Rubber		XF85	H77	0033	71.315	85	MMP-040
	C	Dunkelgelb	7028	XF60	H403	0011	71.025	83	MMP-011
	D	Rotbraun	8012	XF64	H460	0014	71.271	100	MMP-015
	E	Olivgrün	6003	XF58	H405	0002	71.092	117	MMP-009
	F	White	9010	XF2	H11	0047	71.001	34	MMP-001
	G	Wood		XF94	H37	0036	71.077	110	MMP-123
	H	Steel		XF56	H18	0191	71.065	27003	MMM-002
	I	Rust		XF9	H344	0040	71.080	113	MMW-005
	J	Off-White	9001	-	H21	0017	71.270	41	MMP-082
	K	Transparent Green		X25	H94	0092	70.936	1325	-

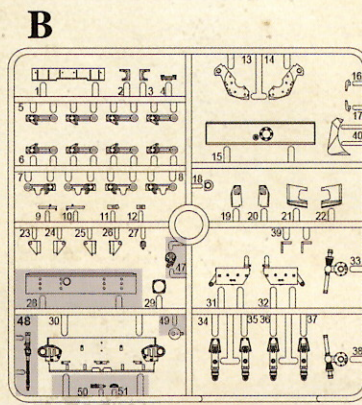
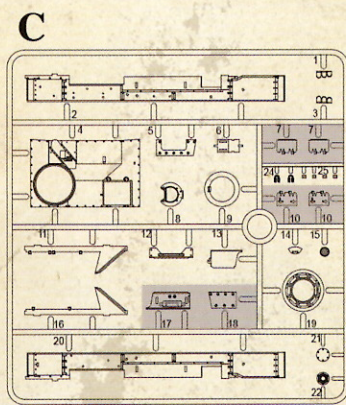
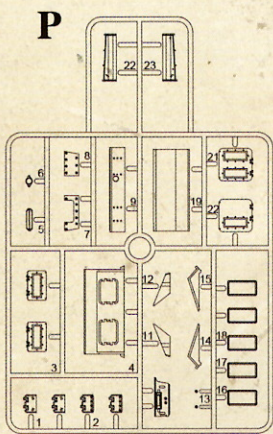
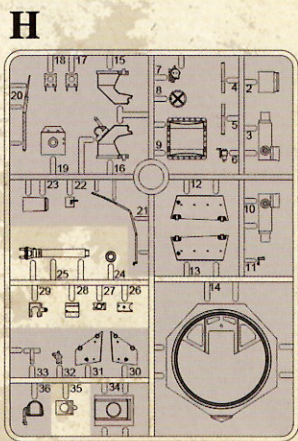
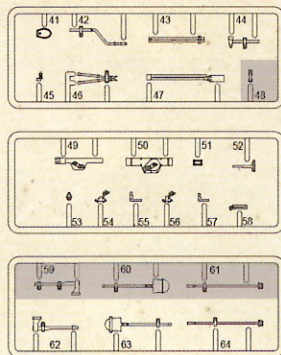
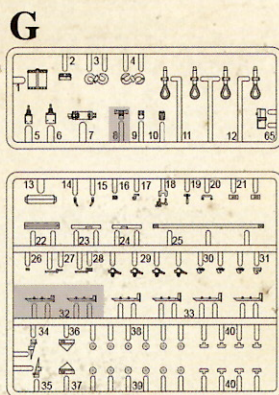
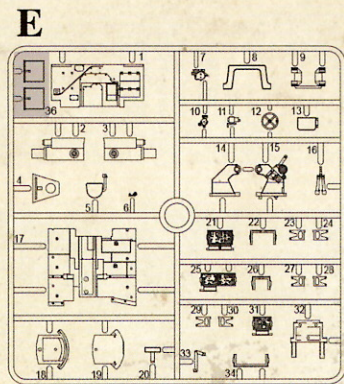
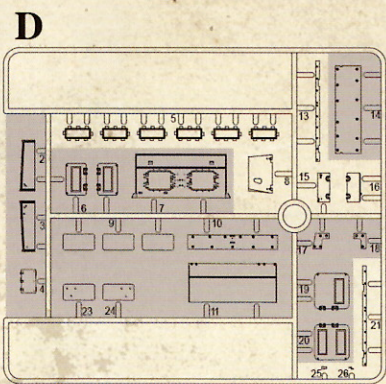

Ax2

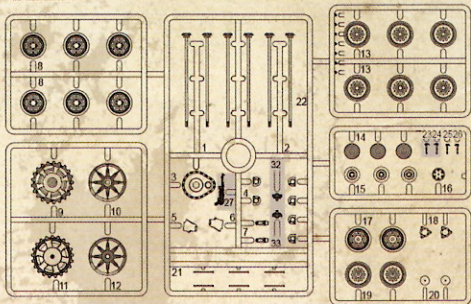

Zx2

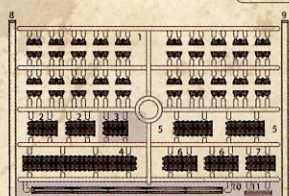

J

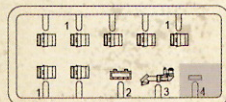

Q

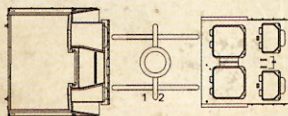

X

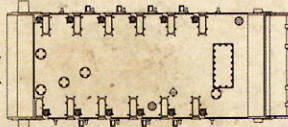

Z (Metal Tow Cable) (340mm)



F

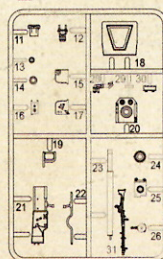

MA (Photo-etched Parts)

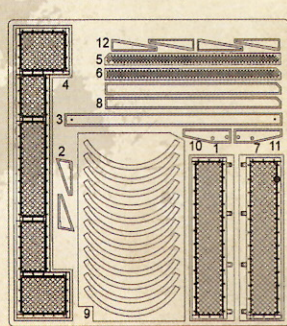

この部品は使用しません
Parts not for use.
Telle werden nicht verwendet.
Pièces a ne pas utiliser.
Parti nin utilizzati.
不需要使用的部件

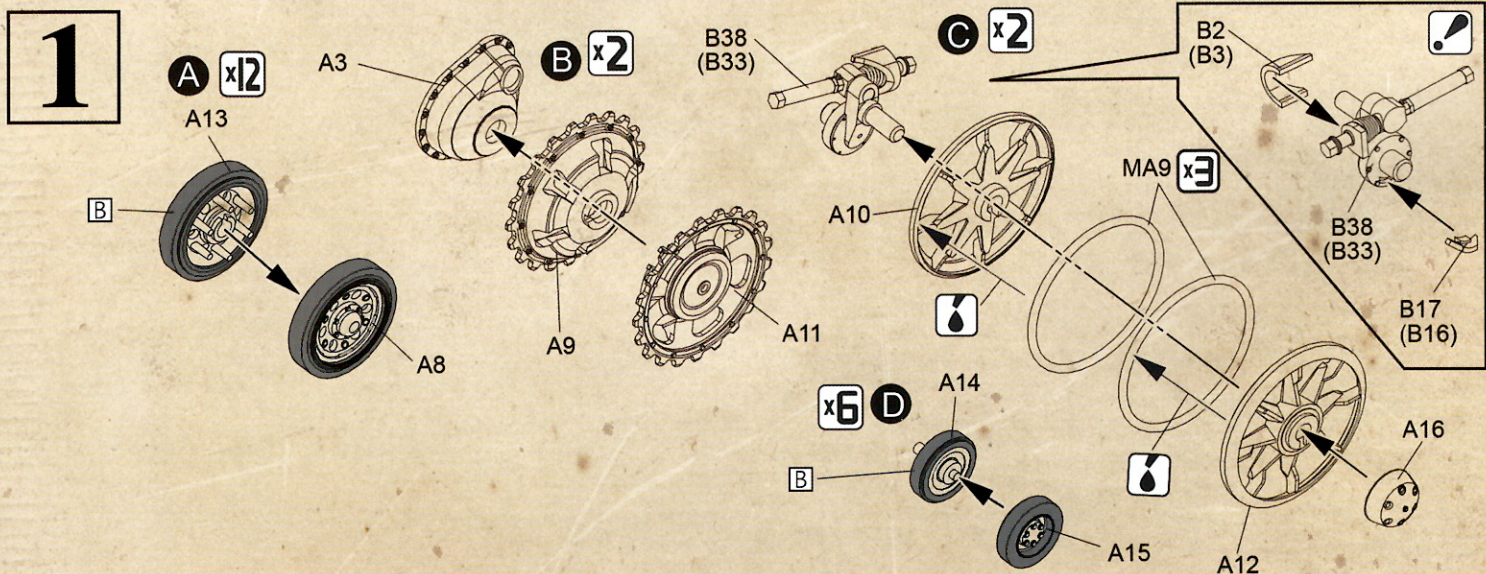

2

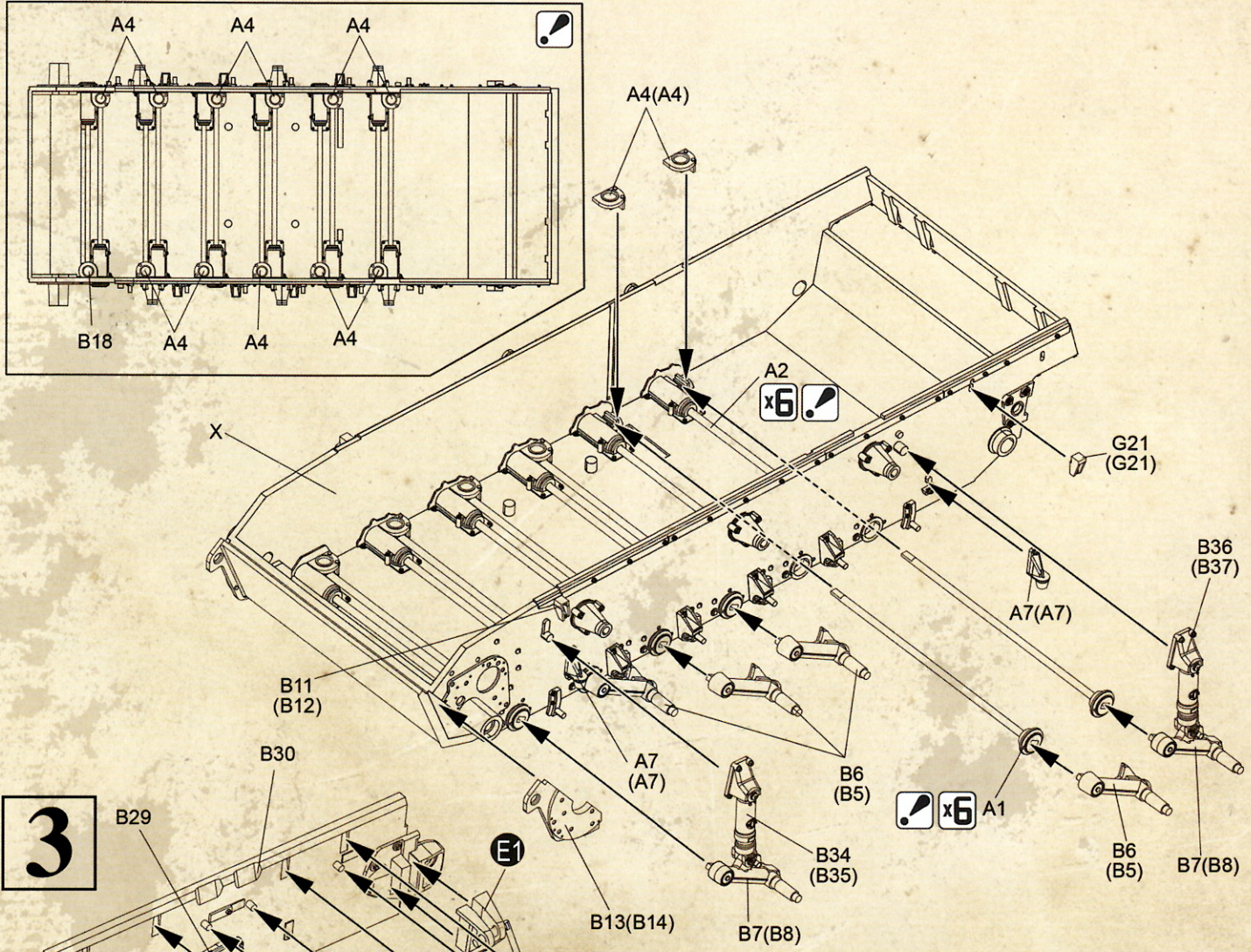

3

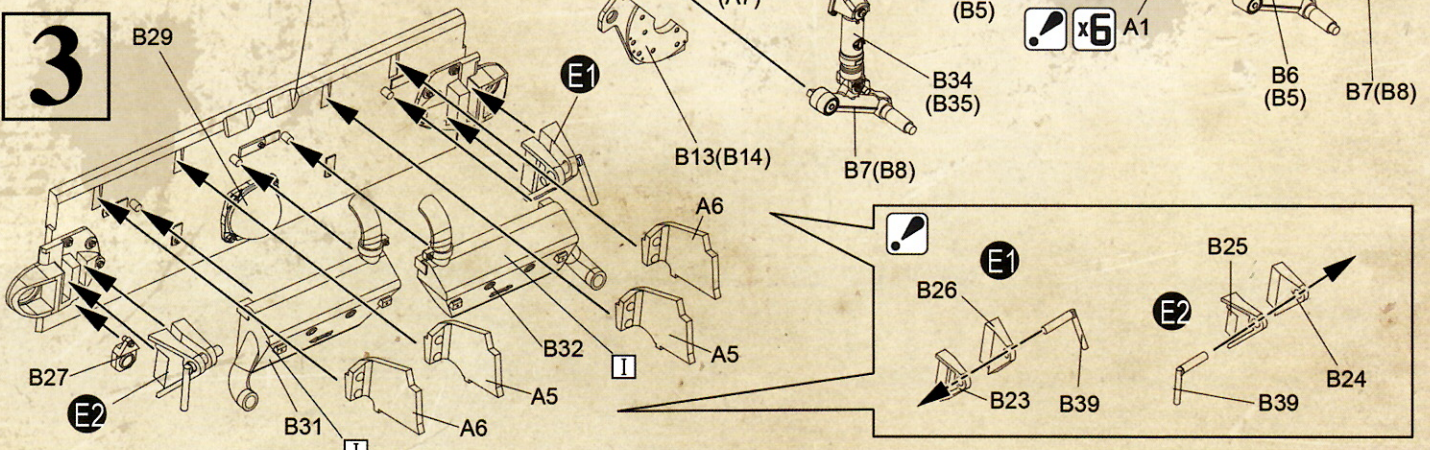

4

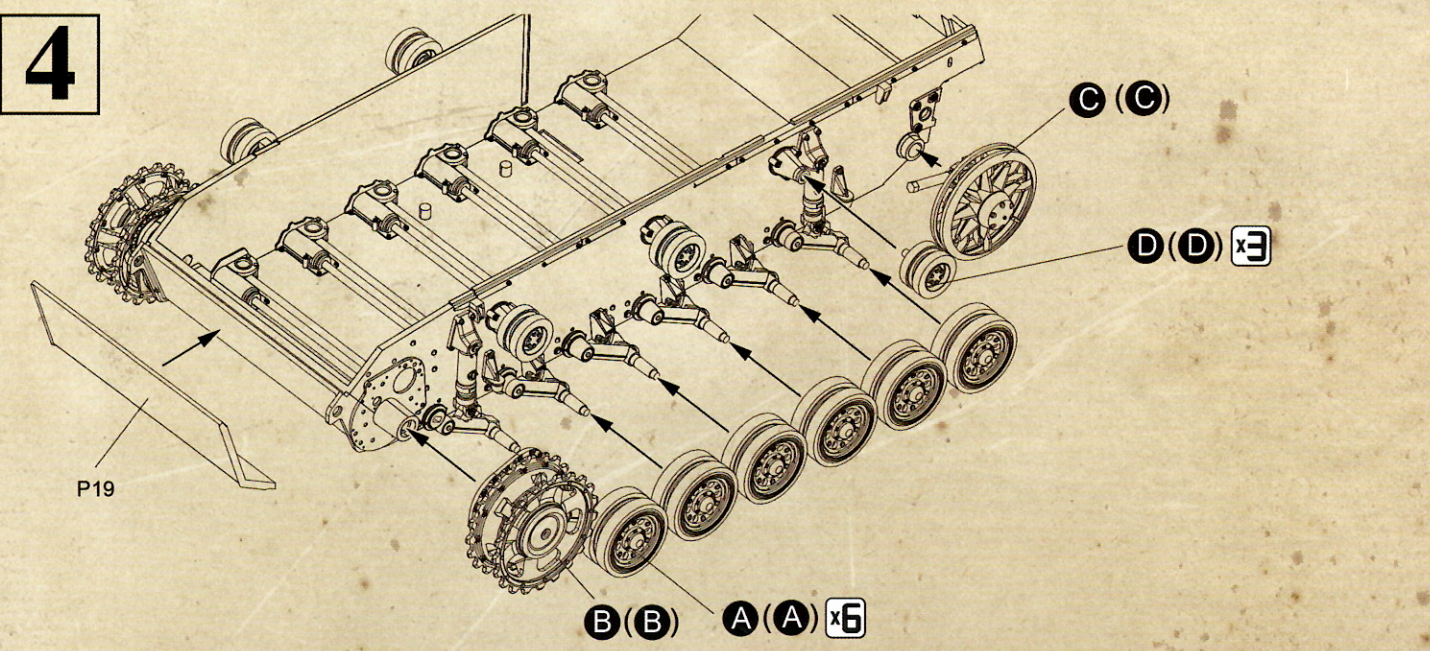

5

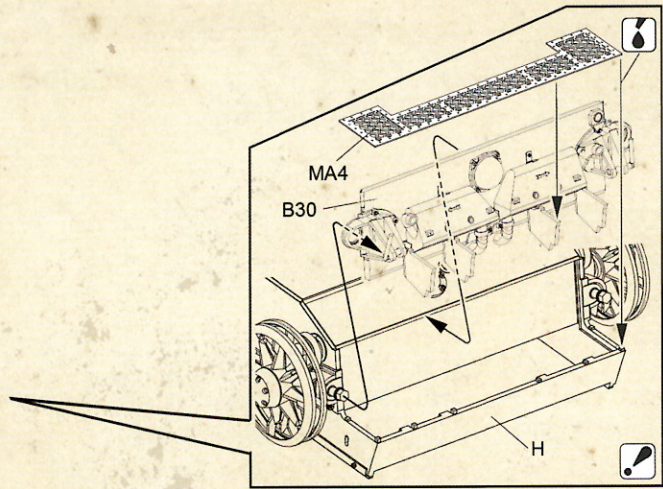
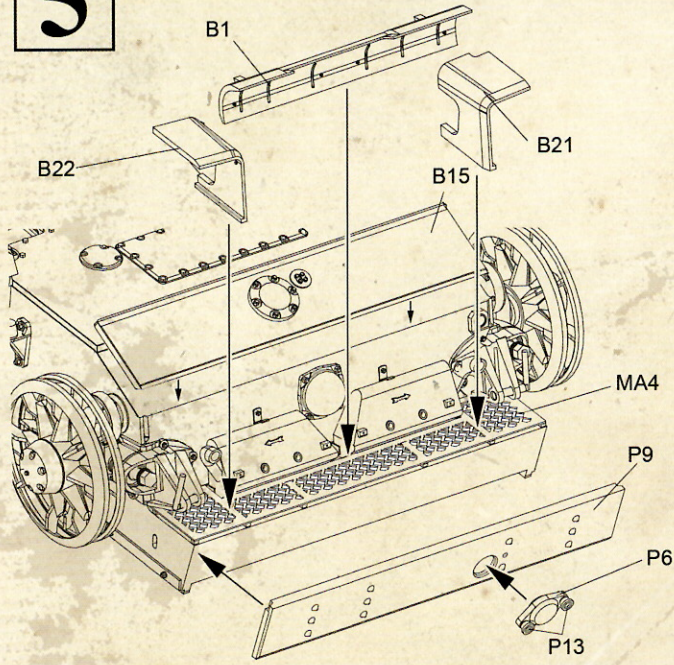

6

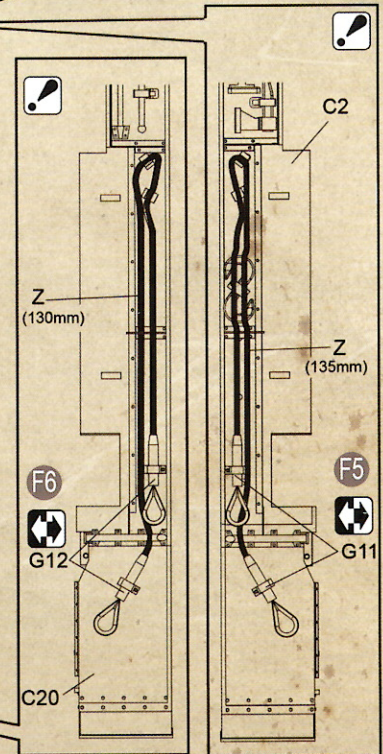
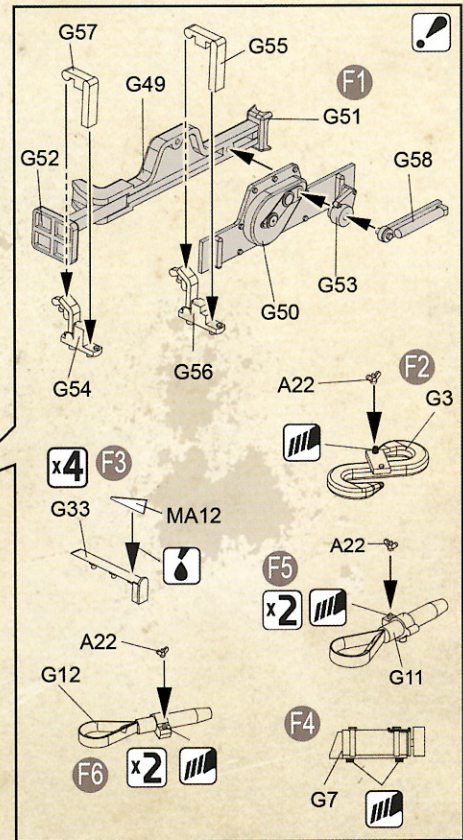
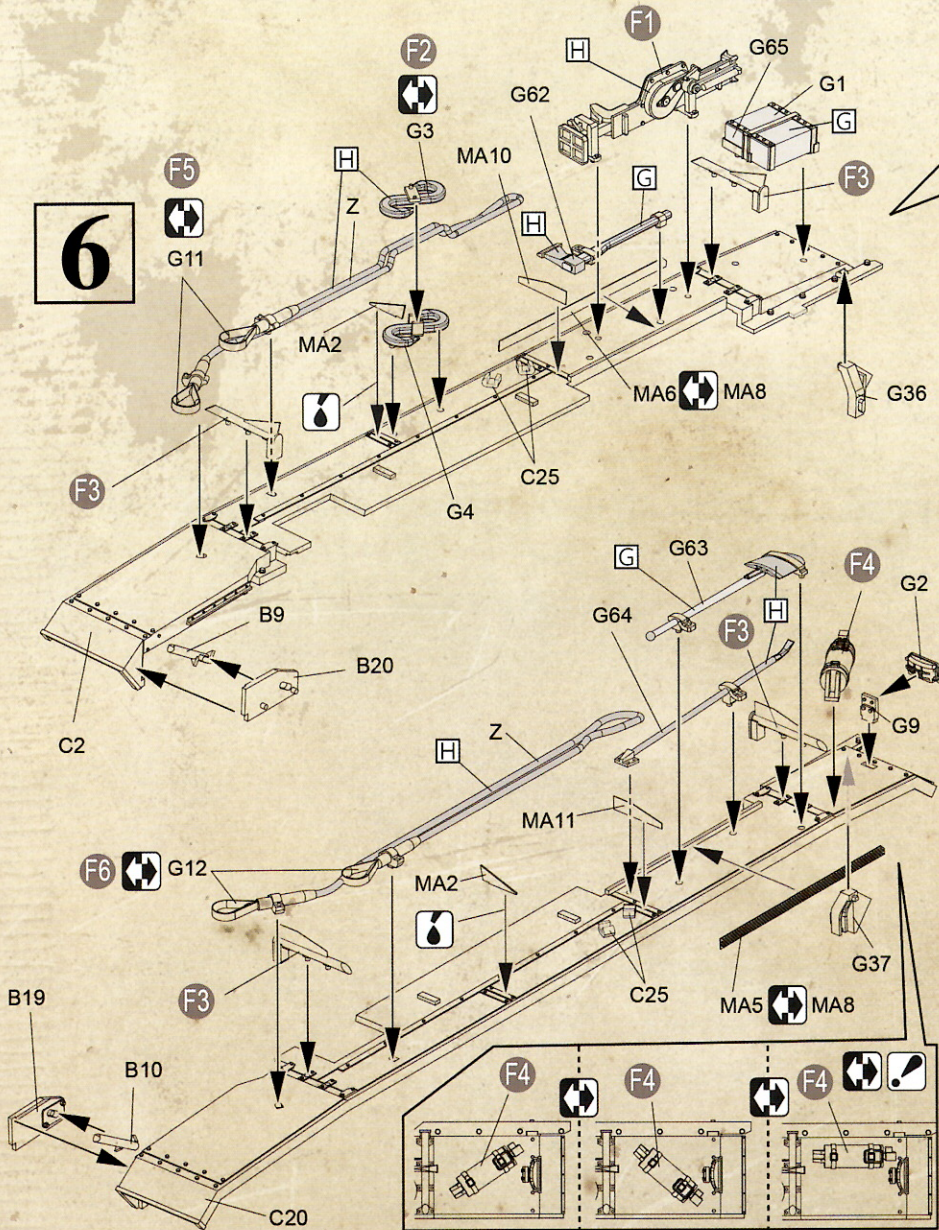

7

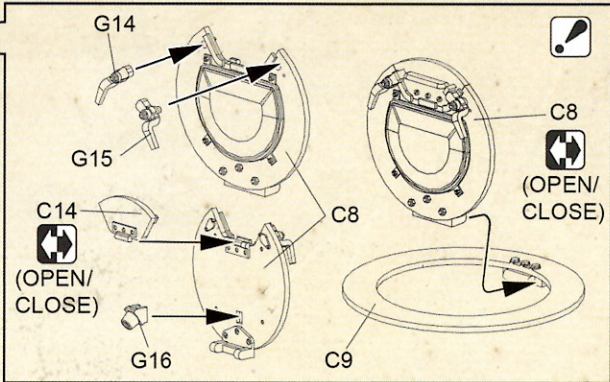
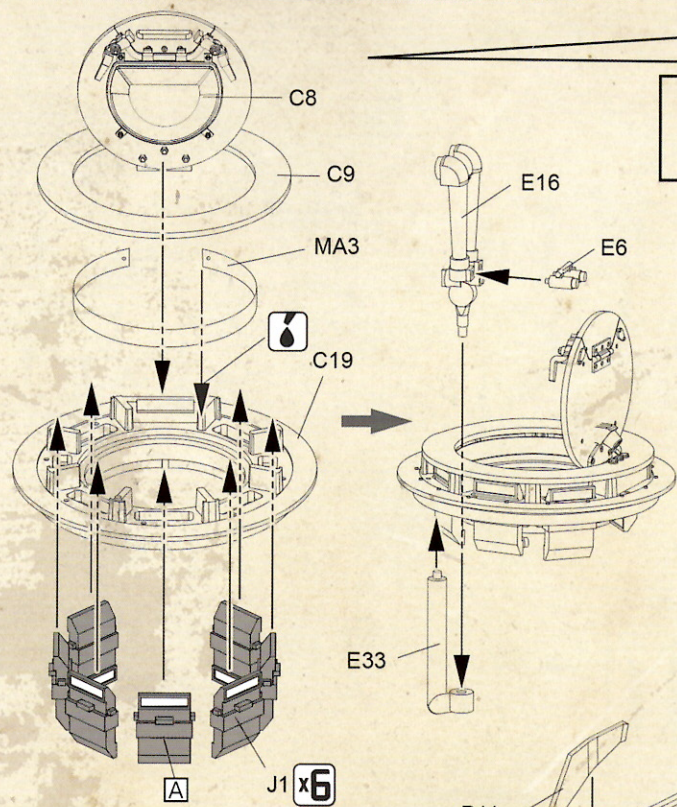

8

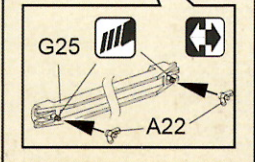
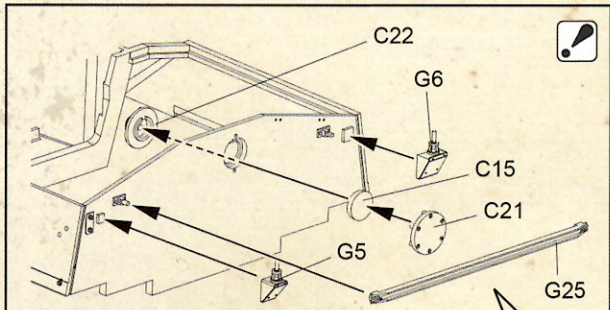
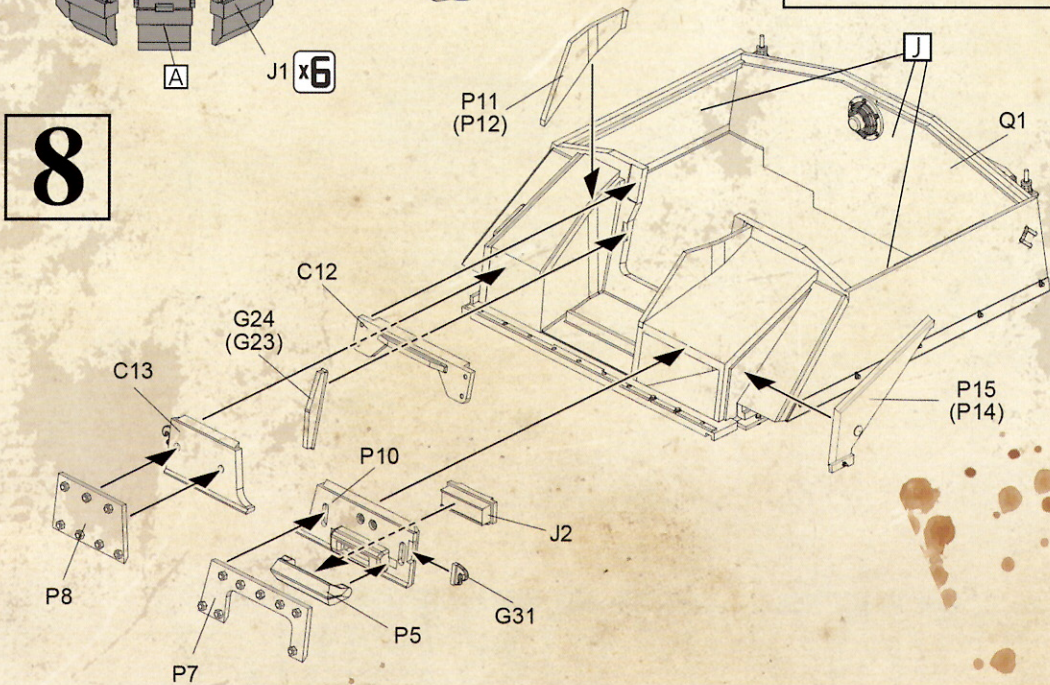

9

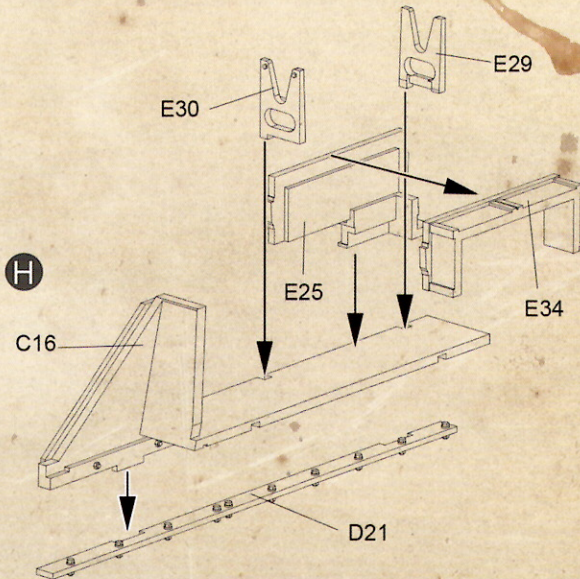
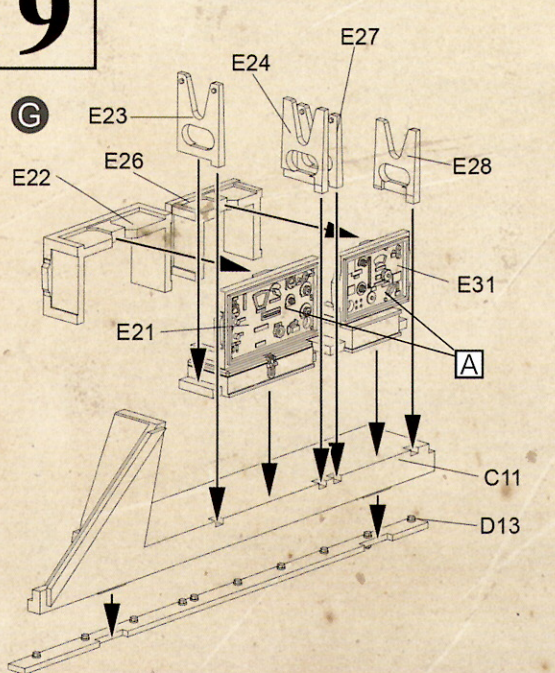

10

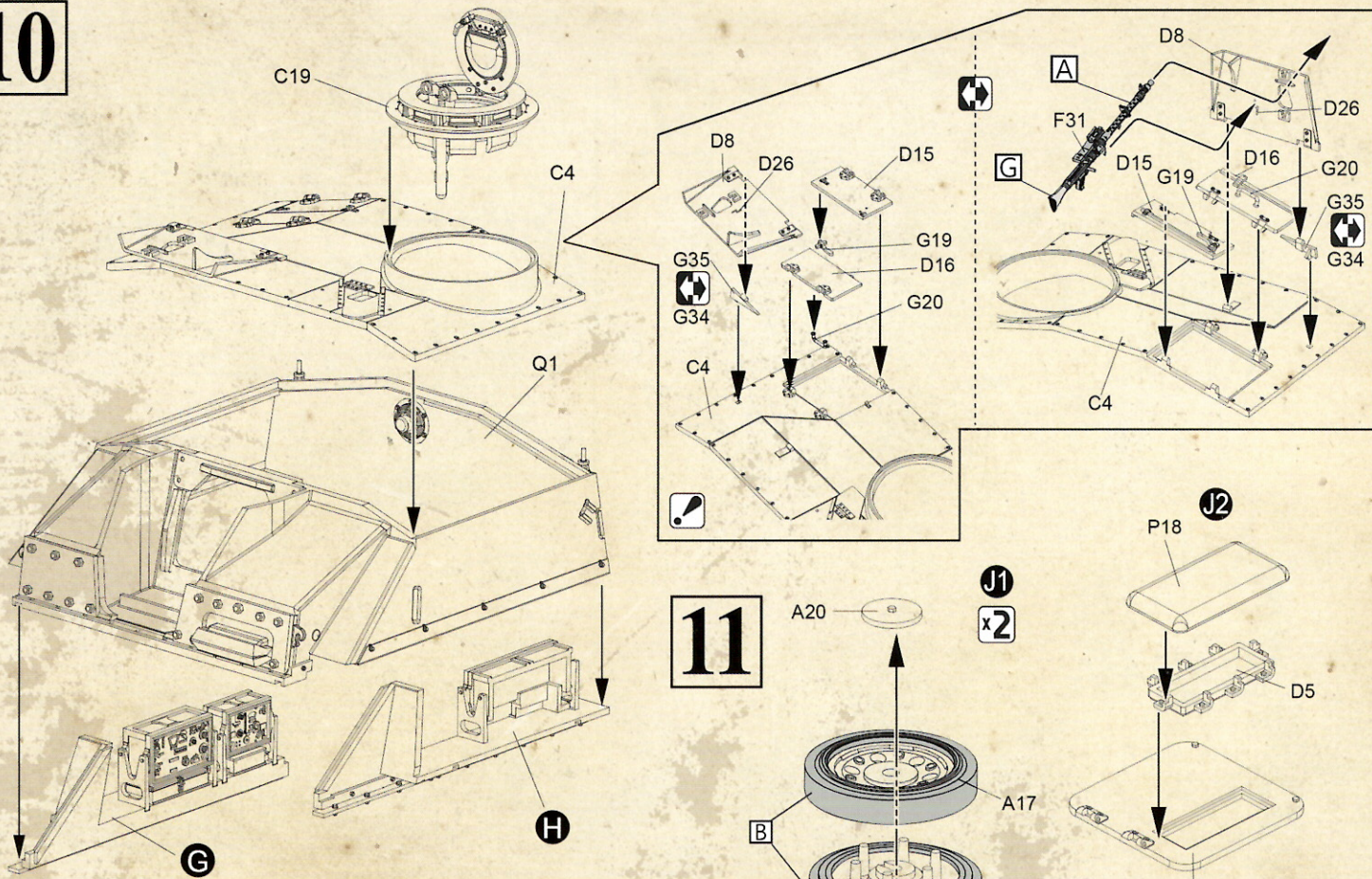

11

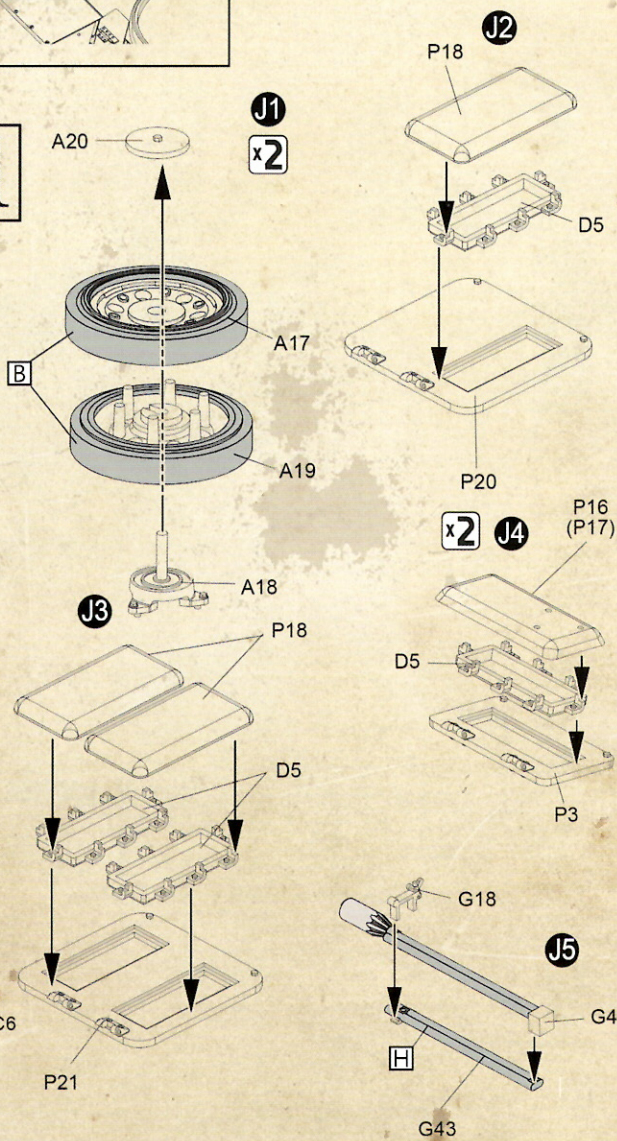

12

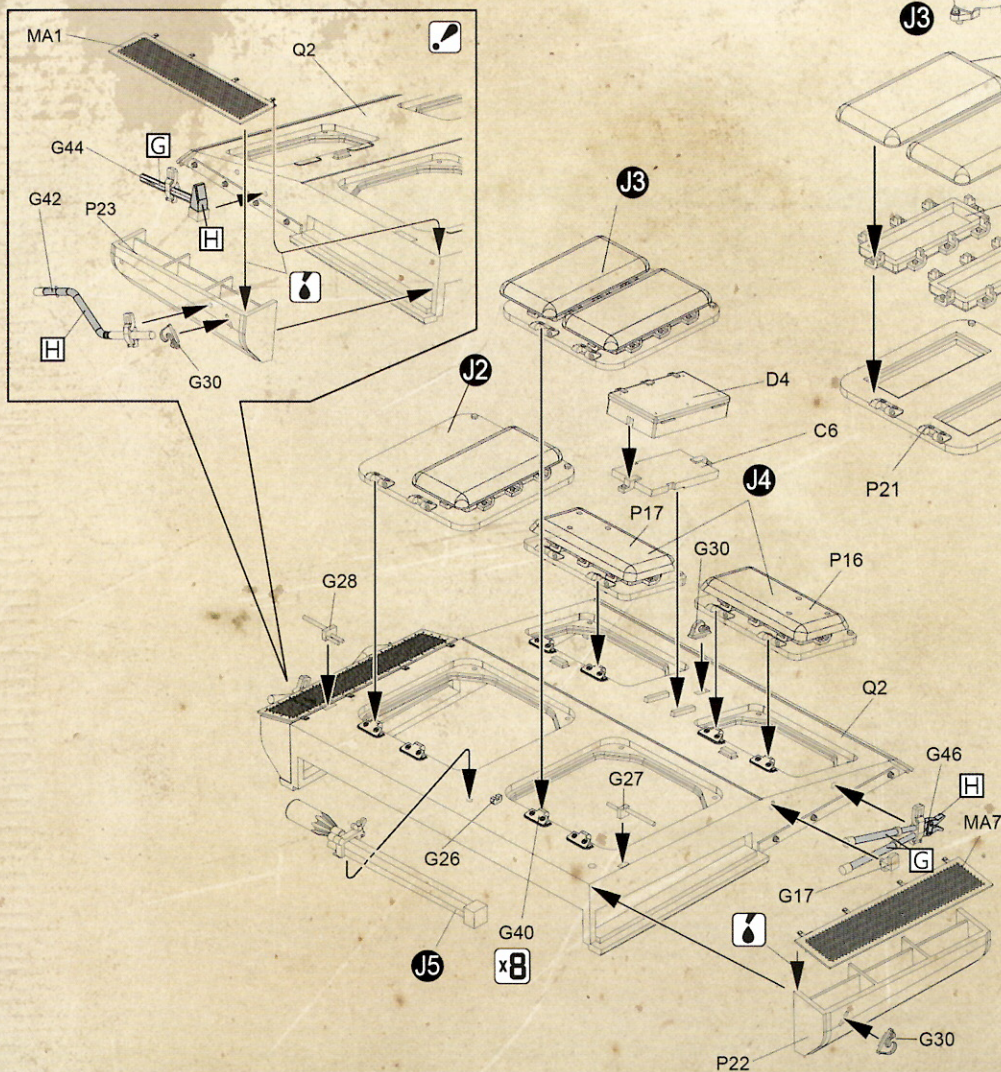

13

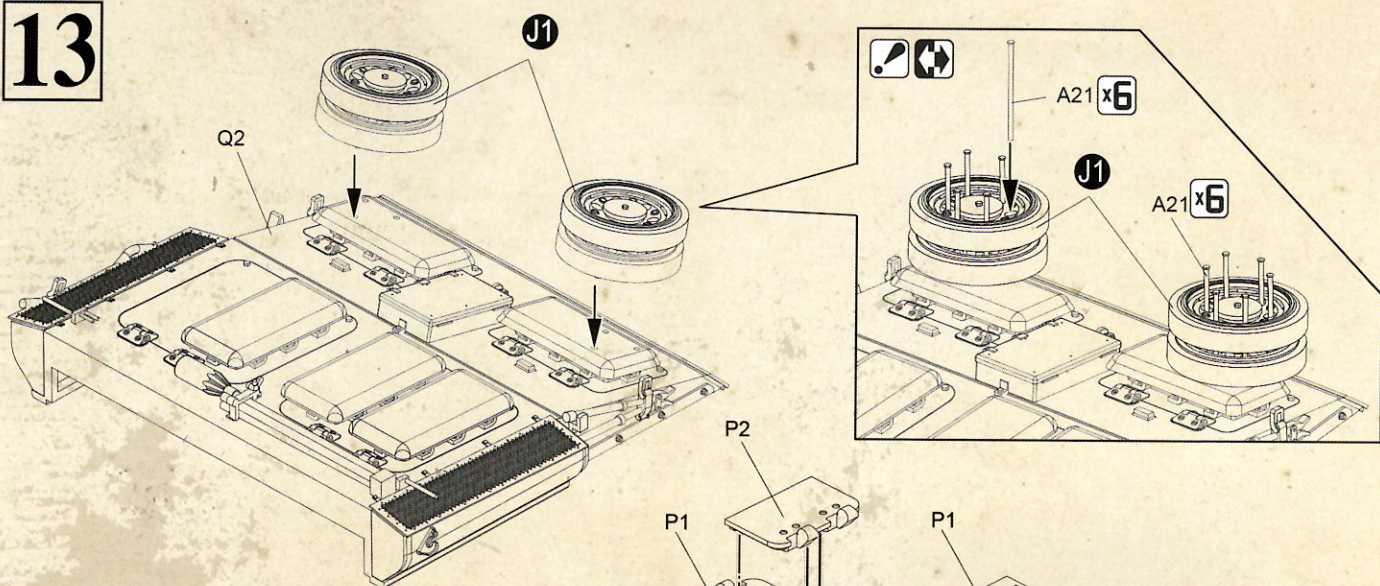

14

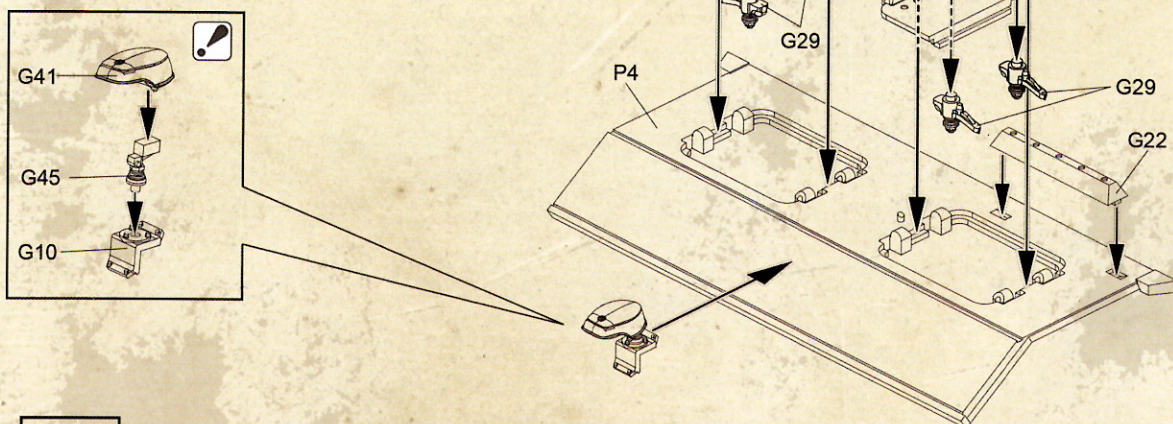

15

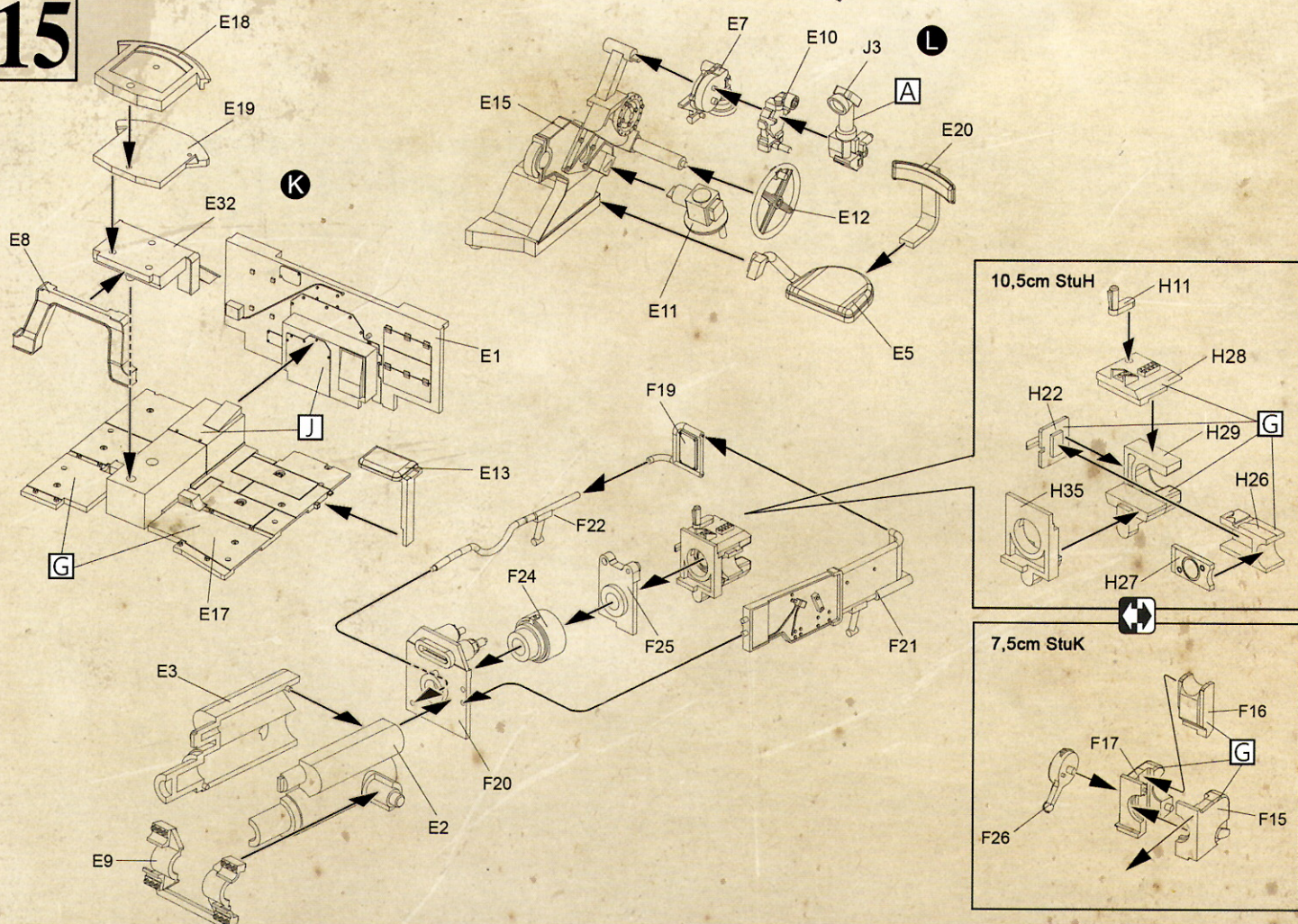

16

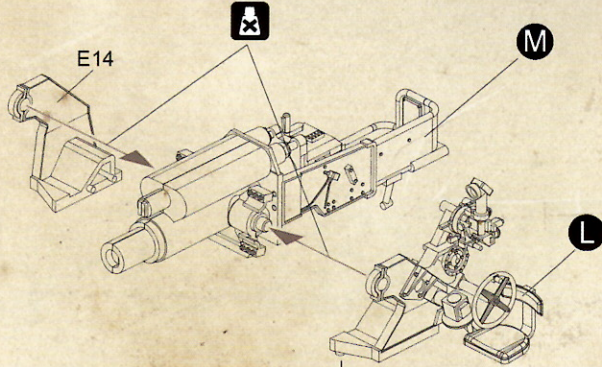
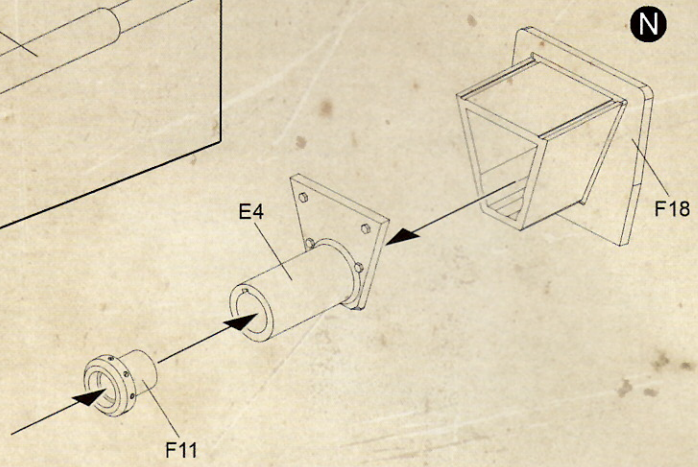
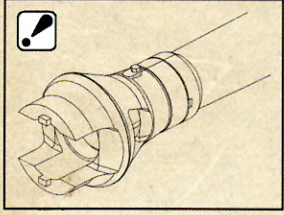
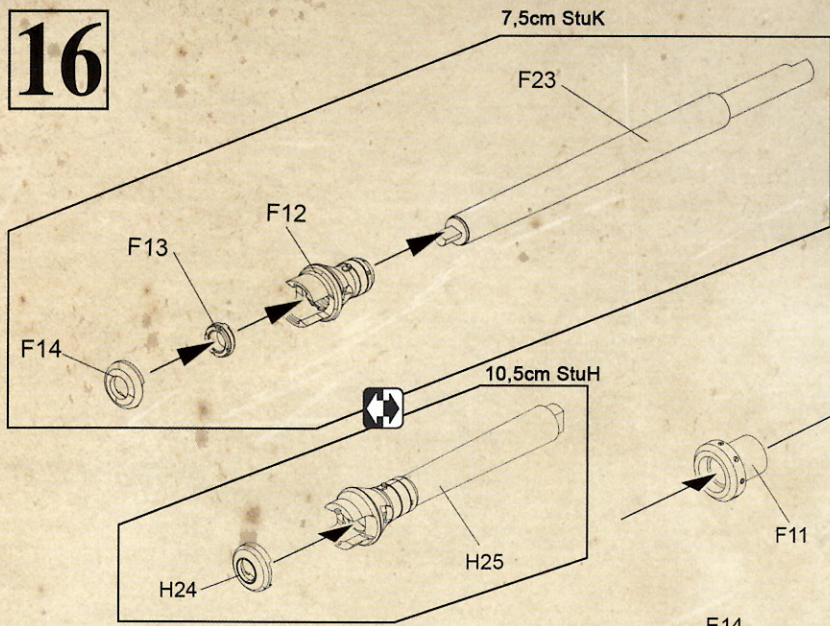

17

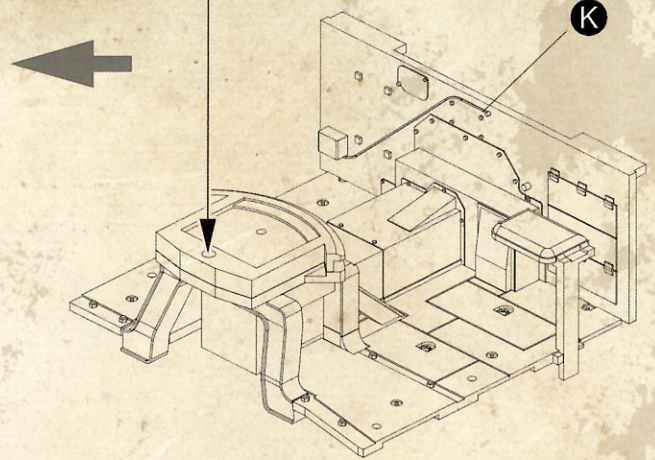
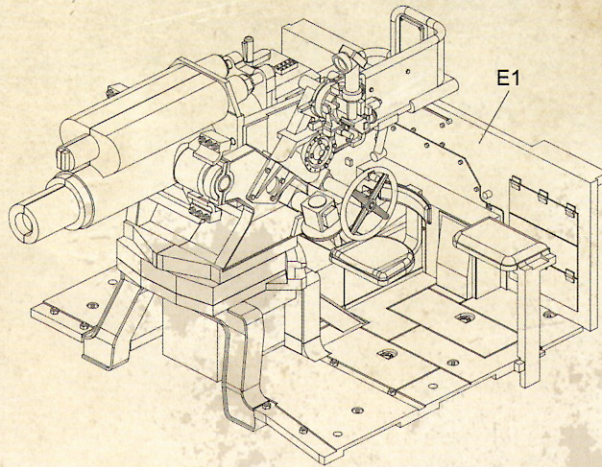

18

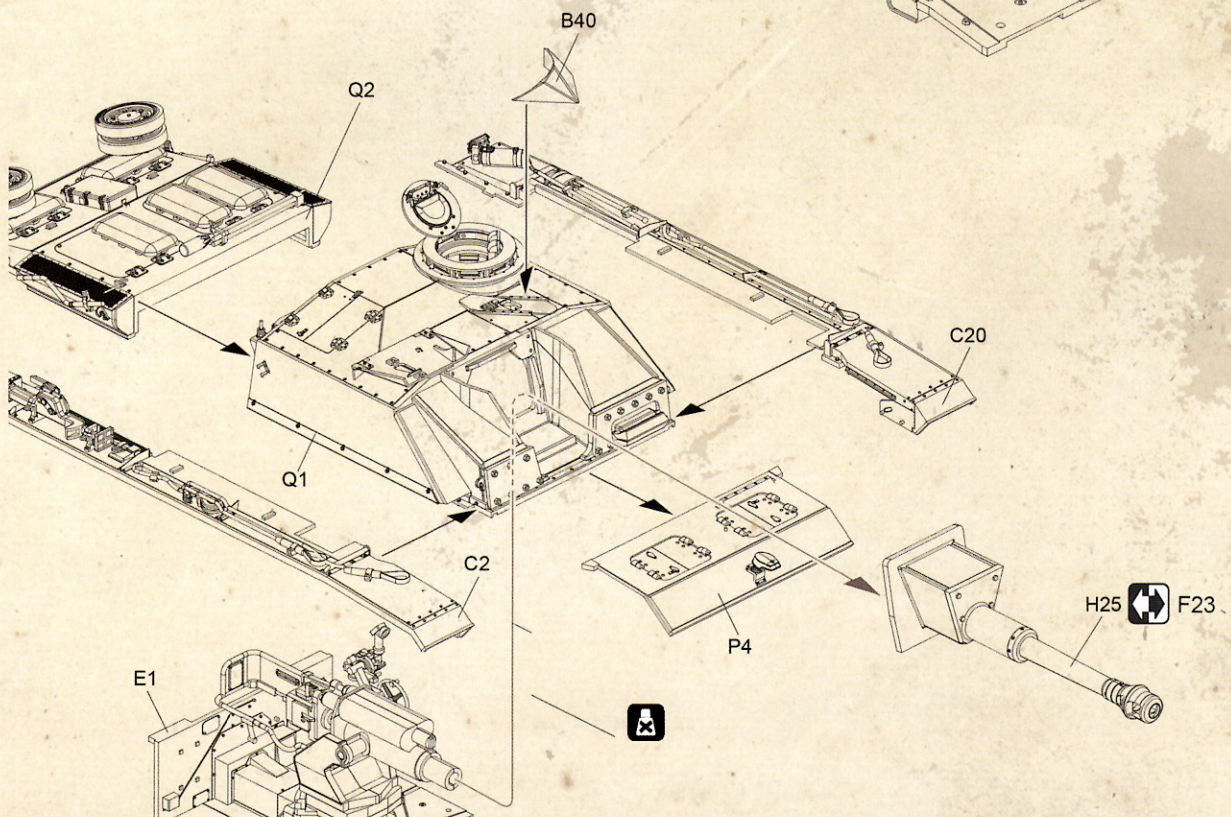

19

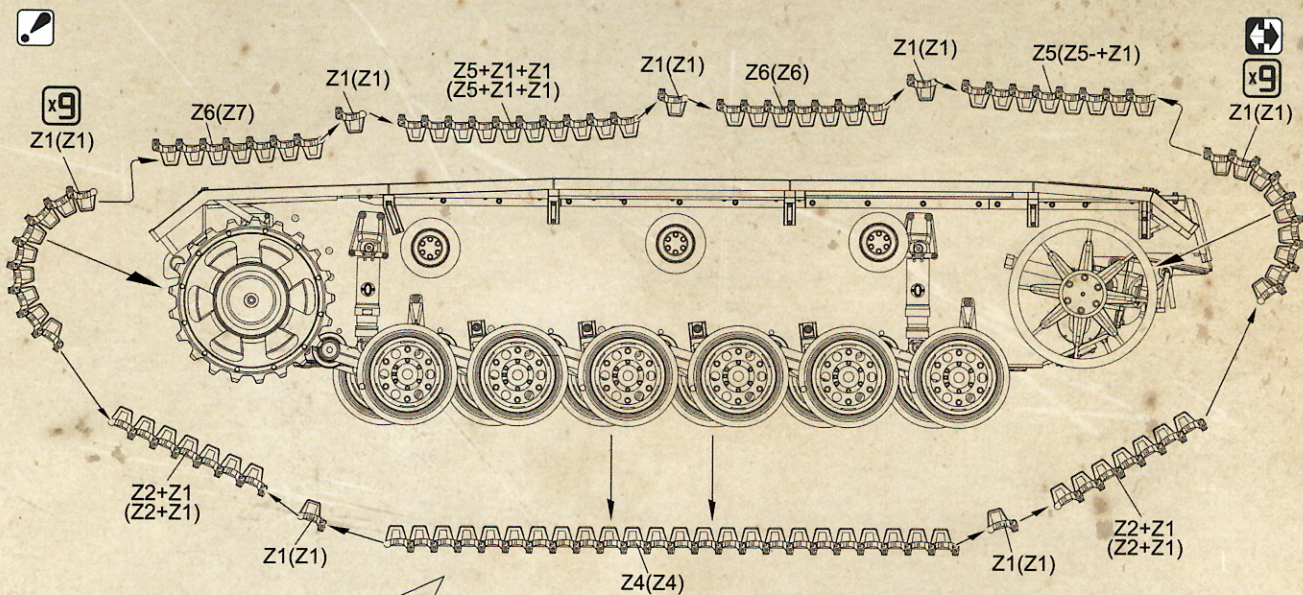

#Although the four upper track sections can be curved, it is not intended that they be continuously bent backwards and forwards. Otherwise, they may break.
 #When creating the track sections on the pre-curved jig, carefully add the track links one by one.

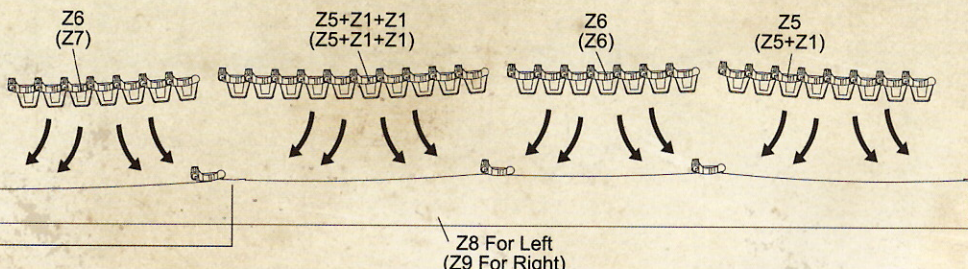
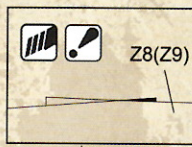

20

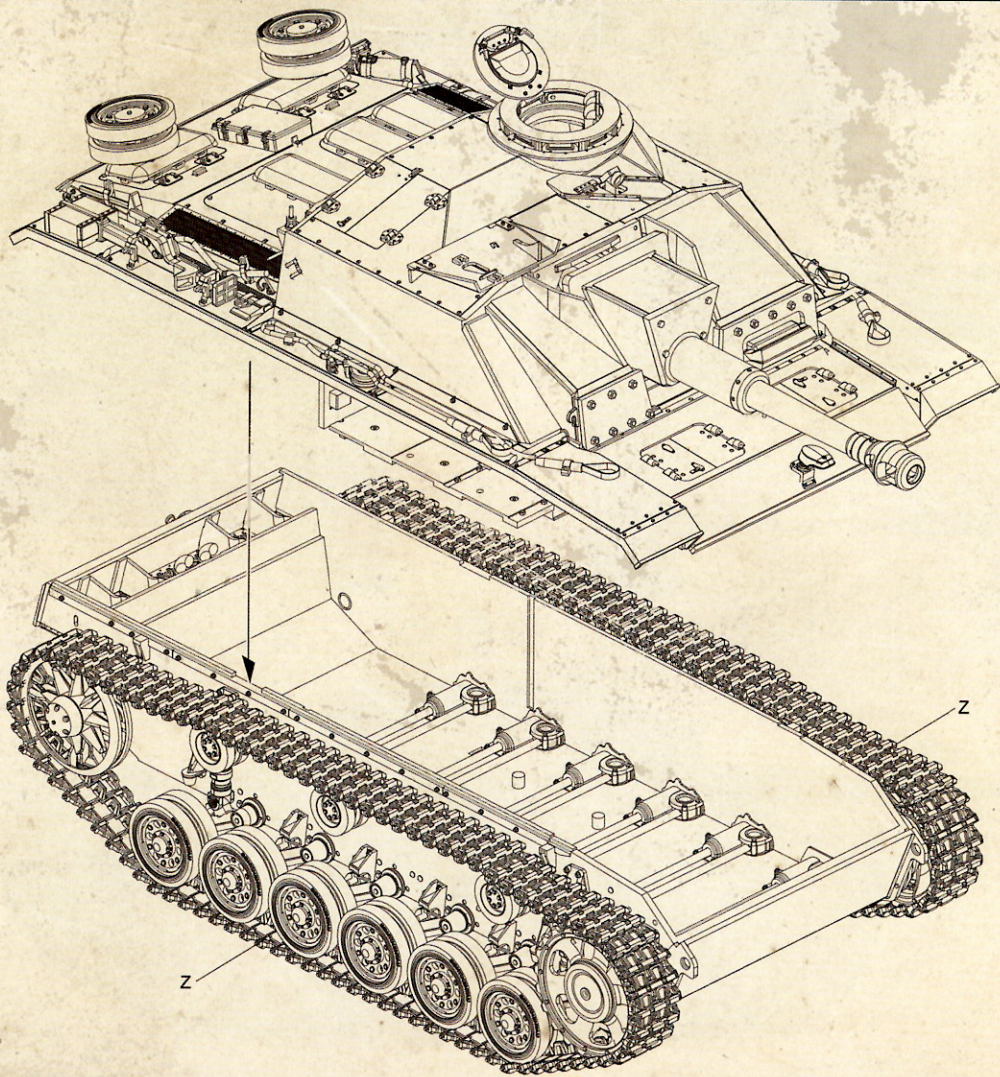

7,5cm StuG III Ausf.G

Painting and Marking Guide

Gebirgs-Panzerjägerabteilung 95, Hungary, late 1944

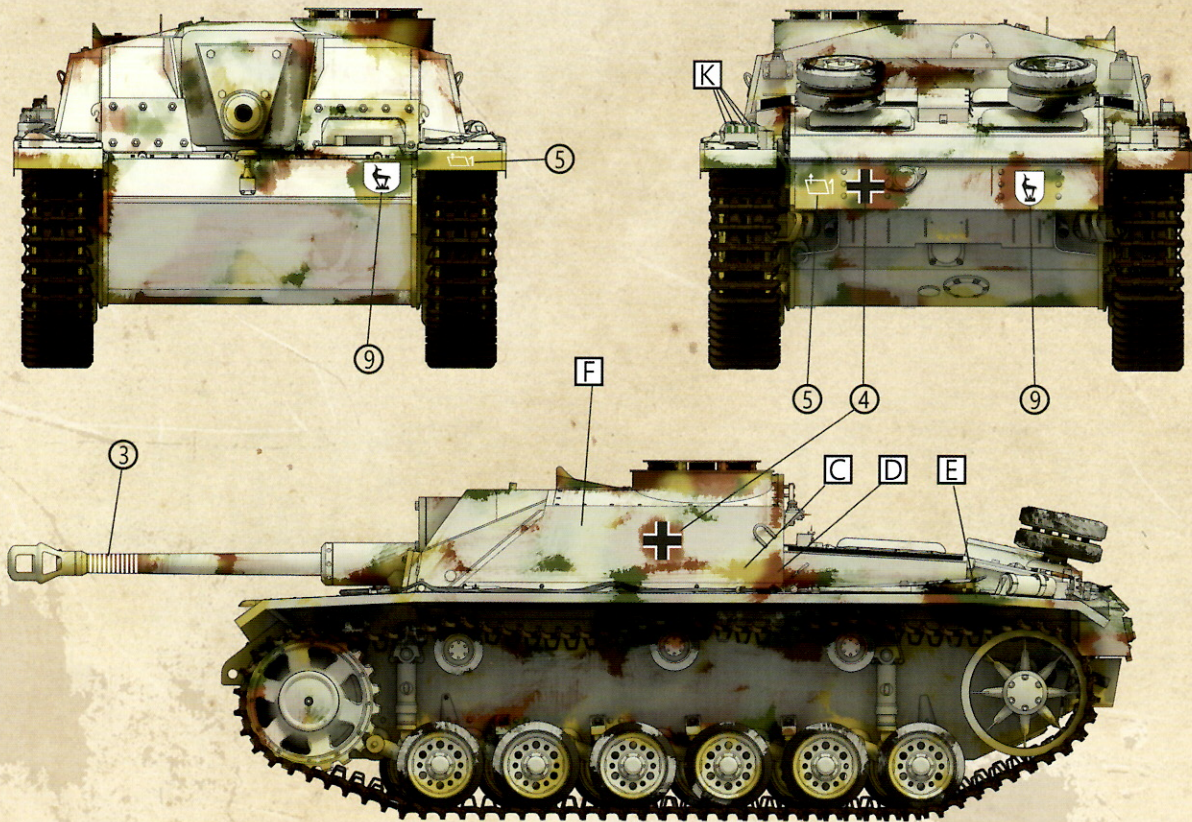

StuG Brig. 277, Lithuania, between Vilnius and Kaunas, July 1944

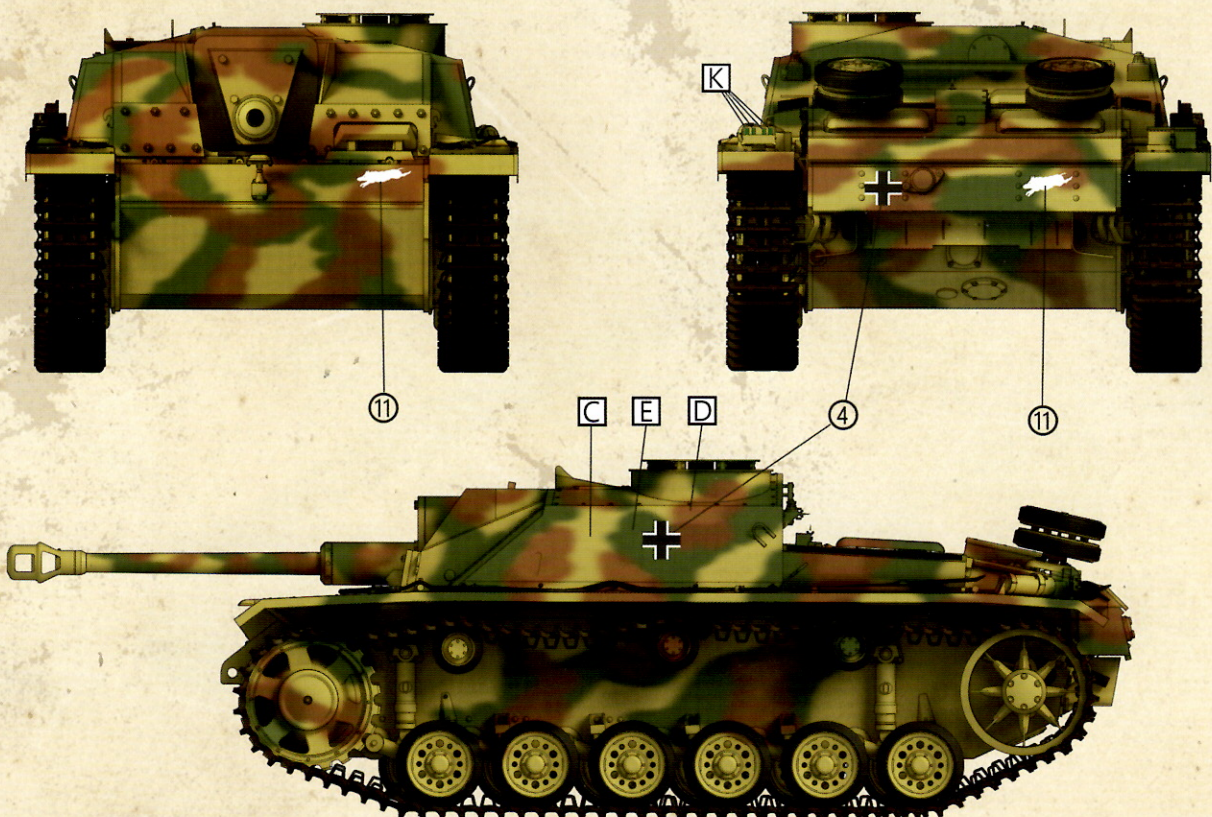

10,5cm StuH42

Painting and Marking Guide

StuG Abteilung 261, Eastern front, late October 1943

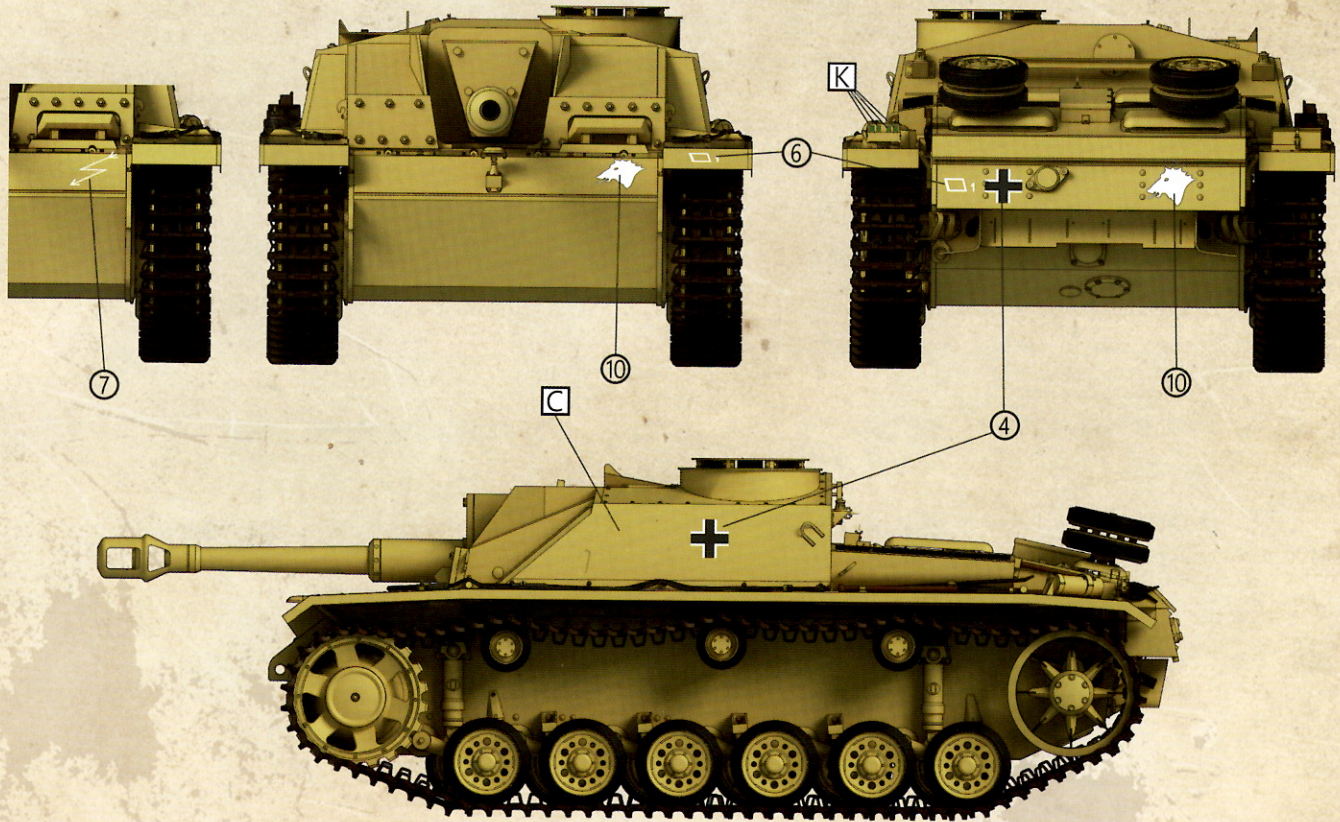

StuG Brig. 322, Kovel, Russia, June 1944

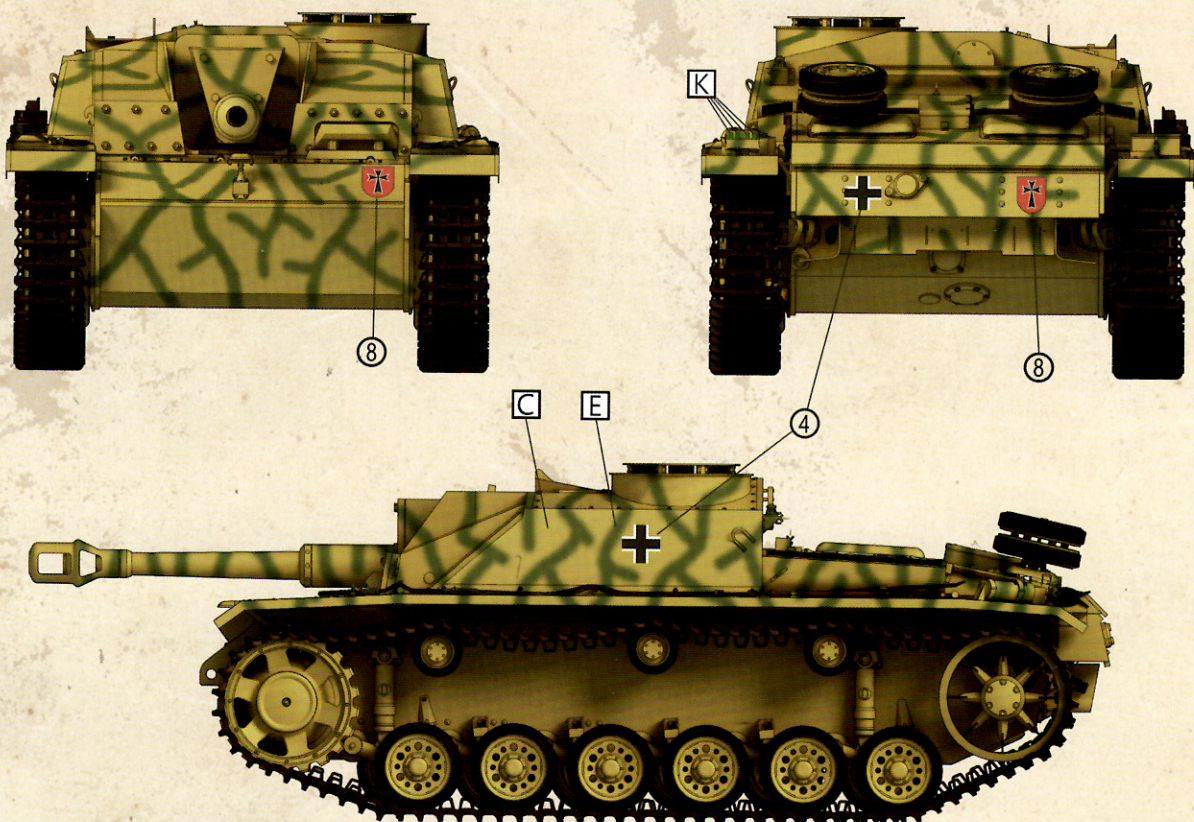

Painting and Marking Guide

StuG Brigade 202, Kurland 1945

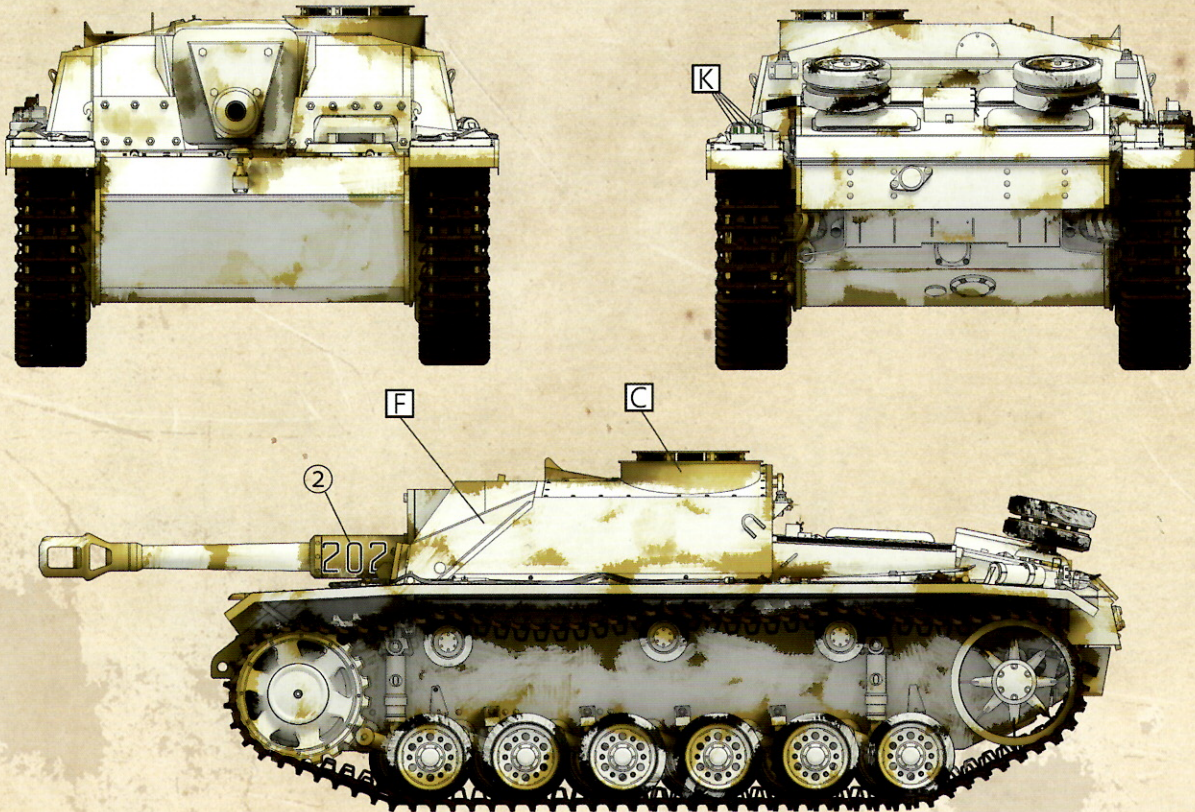

Already available from us in scale 1:35:



35021 - Sd.Kfz.2 kleines Kettenrad



35014 - FMG39/FuSE 62D „Würzburg“



35015 - German Kugelpanzer



35005 - 2cm SMK Type 2



35002 - Sonderanhänger 115



35006 - Einheitsanhänger 5t