



1/35th SCALE

이스라엘 M113 피터 전투 수리차

COMBAT REPAIR VEHICLE I.D.F. M113

FITTER

#1388

The IDF employs almost seven thousands of M-113s as fighting machines, to transport troops, service the other armored units and be a universal do-all to the army. The IDF have had many years of battle-tested experience in which to perfect their modifications to the M-113. Many ideas developed by the IDF have since appeared on the M-113 APC's of the US and other nations using this weapons system. Among the many variants of the Israeli M-113, the FITTER with its externally mounted hoisting crane is very interesting vehicle. FITTER is no exception of which one or two are assigned to each battalion be used by the technical teams within each unit to do repair mission in the field. FITTER can be distinguished as belonging to a battalion of Merkava, Centurion or M-60's by the kind of spare parts they carry. This is made easy and rapid because most of the equipments and spare parts are side-mounted outside the vehicle. And the space of inside is reserved to take a space powerpack which can be discharged by the crane through the large loading door which holded four winged nut in the upper deck. FITTER has a HIAB hydraulic crane with Gearmatic winch made by Canadian company which mounted on the left side of the upper deck which can lift a maximum load of 3,085 kg(6,800 lbs). FITTER also service the Royal Australian army, Belgium army and some of other nation's army.

약 6,500대 가량의 M113을 자국의 실정에 맞게 개조하여 보유하고 있는 IDF(이스라엘 국방군)는 독자적인 M113의 변형 차량이 많기로 유명하다. 그 중에서도 이스라엘군이 각 대대로 1~2대씩을 배치하여 광범위하게 운용하고 있는 전투 수리차인 FITTER는 대단히 특이한 존재라고 할 수 있다. FITTER는 예초에 M-579라는 모델명으로 미국에서 처음 개발되었지만 정작 미국에서는 채용되지 않았고, 월남전 당시 호주군에 의해 최초로 전장에 투입되었다. 호주군은 지금도 이스라엘군과 함께 FITTER를 운용하고 있는 주요 국가이고, 이스라엘군 또한 1980년에 첫 도입되어 오늘에 이르게 되었다. 이스라엘군은 여단 단위 별로 장갑 차량의 종류를 통일시켜서 보급과 수리의 편의를 도모하고 있기 때문에 FITTER 또한, 센투리온, M60, 메르카바등 소속 부대가 운용하는 차량에 따라 그 예비 부품을 구별하여 탑재한다. FITTER의 기본 구조는 M113의 상판에 기존의 큐포리하 상부햇치가 이식된 대형 햇치가 증설되어 내부의 유압 선회 장치와 동력 장치의 수납을 용이하게 하였고 그 장치에 견인 크레인인 연결되어 상판 좌측에 설치된 것이다. 그 외의 각종 예비 부품과 도구류들은 이스라엘군 차량 특유의 '주렁 주렁 매달리기'로 차체를 빙 둘러싸고 있어서 일견 복잡해 보인다. FITTER에 장착된 크레인은 미국제나 이스라엘제 아니고 캐나다에서 제작된 모델 6E HIAB 라는 상품명의 유압식 소형 견인 크레인을 별도 구입하여 증설한 것으로, 최대 직경 3.2m 거리의 견인물중 3,085kg의 중량까지 기증할 수 있다. 차체 외부의 증설물들은 모두 수리에 필요한 도구류, 예비 부품들의 수납 박스 또는 브러켓, 예비 배류류들로, 차량에 따라 여러가지 변칙적인 장착 형태를 보이고 있다. FITTER는 현재 이스라엘군을 비롯하여 호주군, 벨기에군등 여러 나라에서 사용하고 있다.

■ 조립하기전에

- 제품을 조립하기전에 설명서를 꼭꼭지 잘 읽어본다.
- 부품을 자를때에는 칼이나 니퍼로 깨끗이 잘라준다.
- 접착하기전에 부품을 맞추어 확인한 후 접착한다.
- 접착제를 사용할 곳과 사용하지않는 곳에 주의하고 너무 많이 바르지 않도록 한다.
- 에나멜 페인트나 접착제를 사용할때에는 환문을 열어 환기를 시키고 화기를 멀리한다.

- 판매점 문의 A/S센터 : 삼성로 742-9293, 대지동 552-9293, 양재동 575-9997, 용산 706-9293
- A/S 센터 : 본사 908-7000 (공한 147), 동대문 745-9293, 진주동 473-9293
- 총판점 문의 A/S센터 : 노원아카데미 907-0960, 양천아카데미 691-7108, 강남아카데미 522-1577, 김천아카데미 762-0986, 경기아카데미 (0343)458-5551, 부산아카데미 (051)293-7443, 대구아카데미 (053)744-9293, 광주아카데미 (061)969-7000
- ◆ 고객 상담 문의 : 080-969-7000
- 홈페이지 : <http://www.academyhobby.com>

1

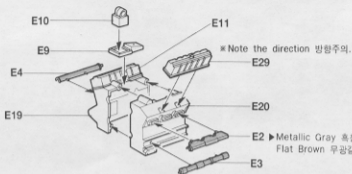

- → Cement. ● - - - - -> Do not Cement. 접착하지 않는다.

- () is opposite decal number. () 안의 번호는 반대편 전사지 번호임.

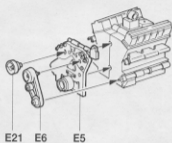

● Engine 엔진전체 ▶ Metallic Gray 흑철색

2



- ▶ Olive Drab 국방색 C44
- ▶ Interior 내부색 ▶ Light Interior 라이트 인테리어

※ Movable 움직인다.

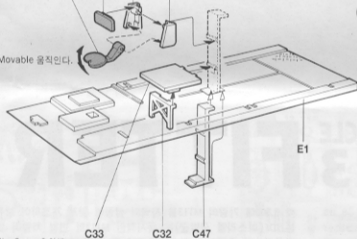

3

- ▶ Metallic Gray 흑철색 + Flat Brown 무광갈색

- E18
- E17
- E27 ▶ Metallic Gray 흑철색

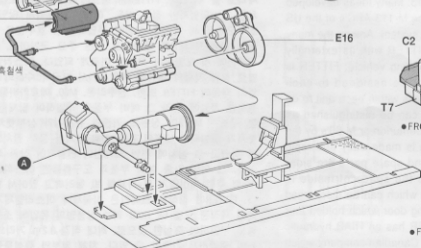

- ▶ Silver 은색 ▶ Silver 은색 + Blue 청색소담 E22

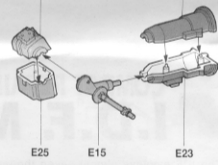

● REAR 뒤

● FRONT 앞

● FRONT 앞

● REAR 뒤

접착한다.
Cement Parts
Glue
Kleben
Peglar
Incollare
Collar
Kleben

접착하지 않는다.
DO NOT cement
NE use other
Nicht kleben
NO Peglar
NGK incollare
Nao colar
Niet kleven

잘라낸다.
Cut away
Cleave
Scheiden
Cortar
Tagliare
Cortar
Schnitten

선택한다.
Optional parts
Chose
Auswahlmoglichkeiten
Electio
Sceita
Opcao
Khuze

수만번 반복한다.
Repeat operation
Repetir il operacion
Vorgang wiederholen
Repetir la operacion
Repetire
Repetir a operacion
Herhalen

4

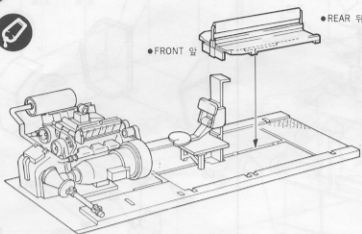

DECAL APPLY 전사지의 부착

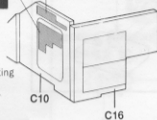

Apply decals after painting
색칠후 전사지를 붙인다.

5

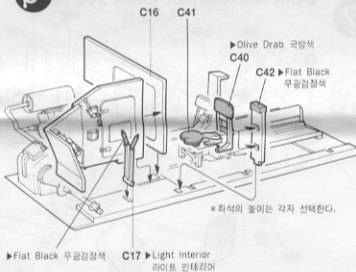

회색의 돌이는 각자 선택한다.

Flat Black 무광검정색 C17 Light Interior
라이트 인테리어

6

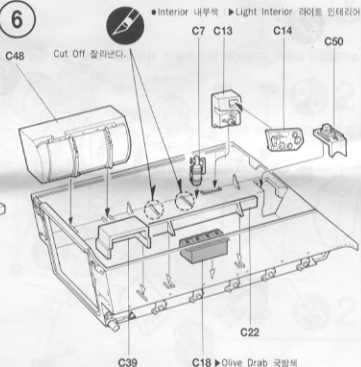

7



PAINTING(C14) 계기판(C14)의 색칠

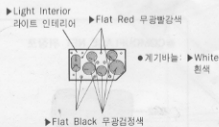

PAINTING(C7) 소화기(C7)의 색칠

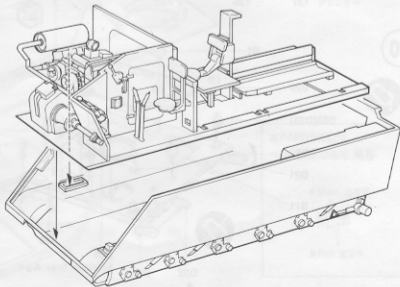

8

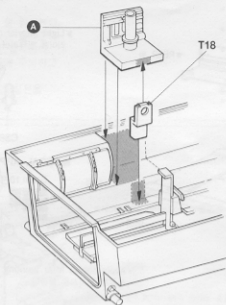
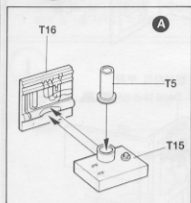

B

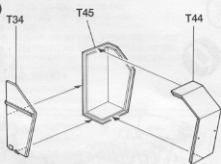

D6

D12

C

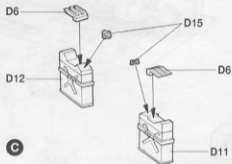

9

■ ISRAELI ARMY VERSION 이라열군 사용차림 D32

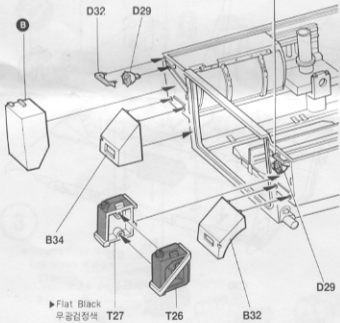

▶ Flat Black
무광검정색

■ ROYAL AUSTRALIAN ARMY VERSION 호주군 사용차림

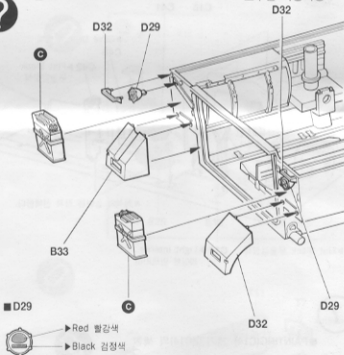

▶ Red 빨간색
▶ Black 검정색

10

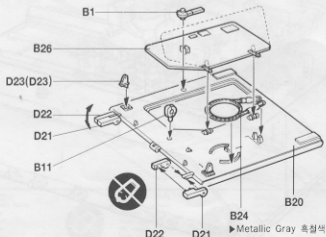

▶ Metallic Gray 흑철색

■ COMOUFLAGE NET 위장모



▶ Olive Drab 옥망색



▶ Attach accessories your desire.
악세서리 부품은 자유롭게 장착한다.

11

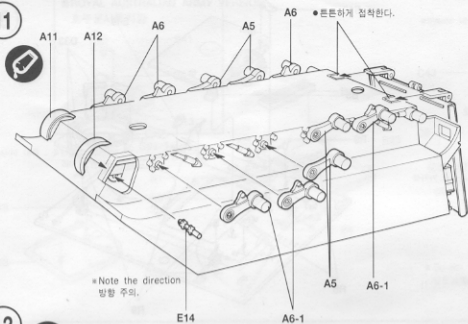

12

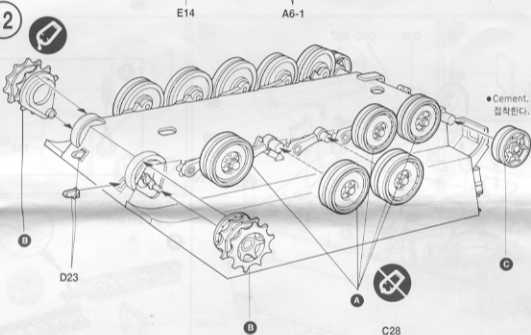

13

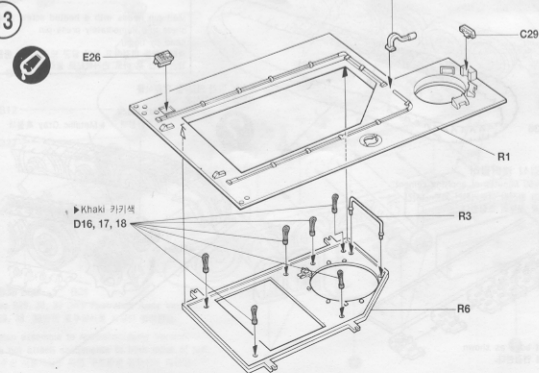

ROAD WHEEL 전용

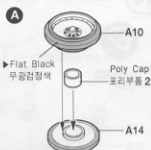

10

DRIVE SPROCKET

스프로킷 휠

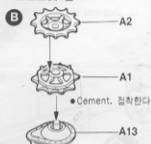

2

IDLER WHEEL 아이들러 휠

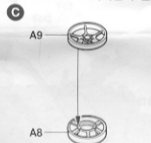

2

PAINTING(29)

경고등(C29)의 색칠

▶ Black 검정색

▶ Red 빨강색

14

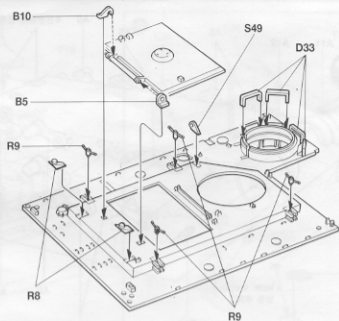
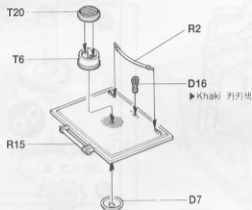

15

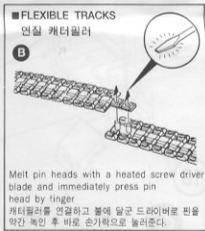
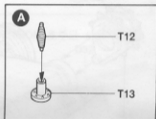
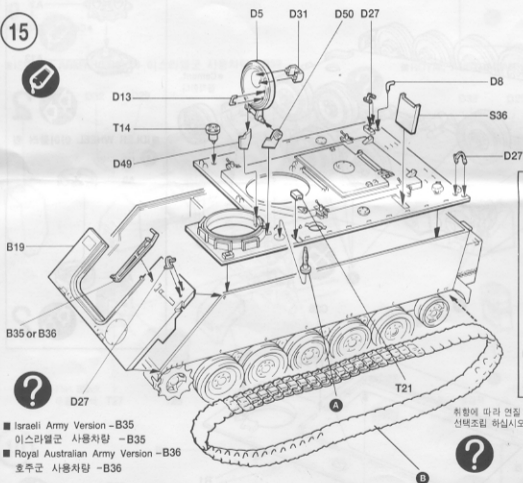

■ FLEXIBLE TRACKS
연식 캐터필러

Melt pin heads with a heated screw driver and immediately press pin head by finger
캐터필러를 연결하고 볼에 달고 드라이버로 핀을 약간 녹인 후 바로 손가락으로 눌러준다.

- Israeli Army Version - B35
이스라엘군 사용차량 - B35
- Royal Australian Army Version - B36
호주군 사용차량 - B36

■ INDIVIDUAL TRACKS 연식식 캐터필러
 ● From the tracks within 30~60 Minutes of applying cement.
 캐터필러를 연결시킨 후 접착제가 완전히 마르기전인 30분~1시간
 사이에 조심스럽게 알맞은 형태로 구부려 조립한다.

- Flat Black
무광검정색
- Metallic Gray
흑합색

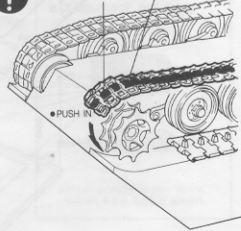

● Assemble the treads against edge as shown
 자동차를 이동하여 벽돌이 지지 않게 연결한다.

16

ROYAL AUSTRALIAN ARMY VERSION

호주군사용차량

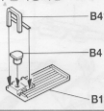

B14

D27-1

B23

● Inside 내측 ▶ Light Interior 라이트 인테리어

B18

B7

B9

B6

B16

D28

● Inside 내측 ▶ Light Interior 라이트 인테리어

C43

C8

C15

C9

Decal 14 전사지
▶ Metallic Gray 흑철색

Decal 16 전사지

E13

E12

C49

▶ Metallic Gray 흑철색

■ Do not fix C49, when you assemble closed position, 닫힌상태에서는 C49를 조립하지 않는다.

A

T24

T23

B

T10

T9

C

T22

T19

T17

T19

17



B8

B28

D4

B12

B27



B38 B39

B29

■ Use B29, 38, 39 Only Australian Army Version.
B29, 38, 39번은 호주군사용 차량만 접착한다.

■ When assemble to Australian Army Version,
Do not attach equipments to both sides of hull,
호주군 사용차량은 측면 구조물을 접착하지 않는다.

▶ Silver 은색 ▶ Black 검정색
▶ Silver 은색 ▶ Black 검정색



B28



B27

C

D

▶ Flat Black 무광검정색

T2(T3)

T1(T4)

18

■ CUPOLA 큐포라

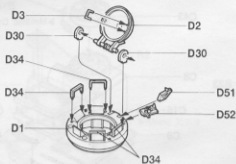

■ Cal. 50 ASSEMBLY Cal. 50의 조립



19

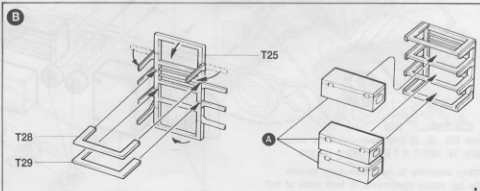
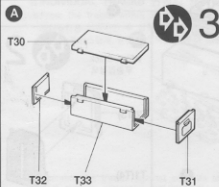
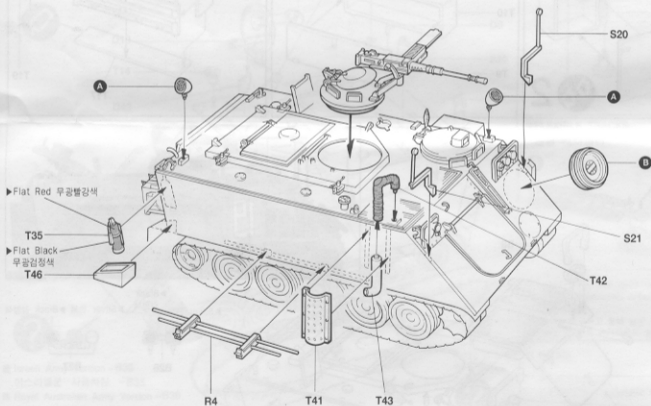

20

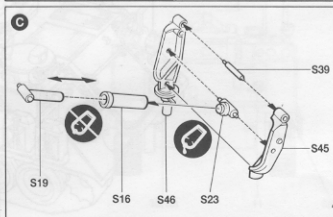
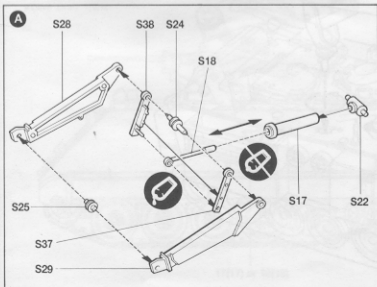
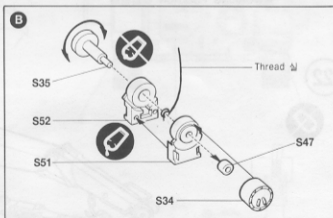
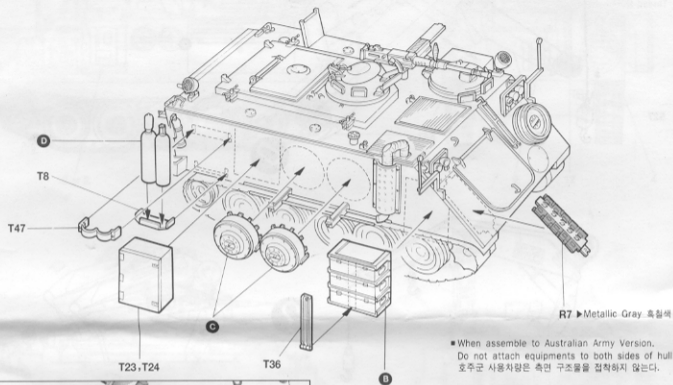
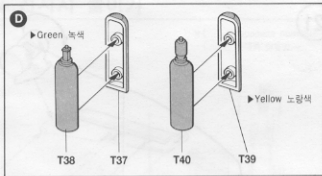
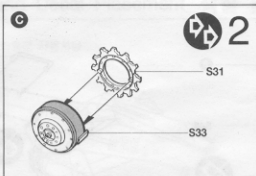

21

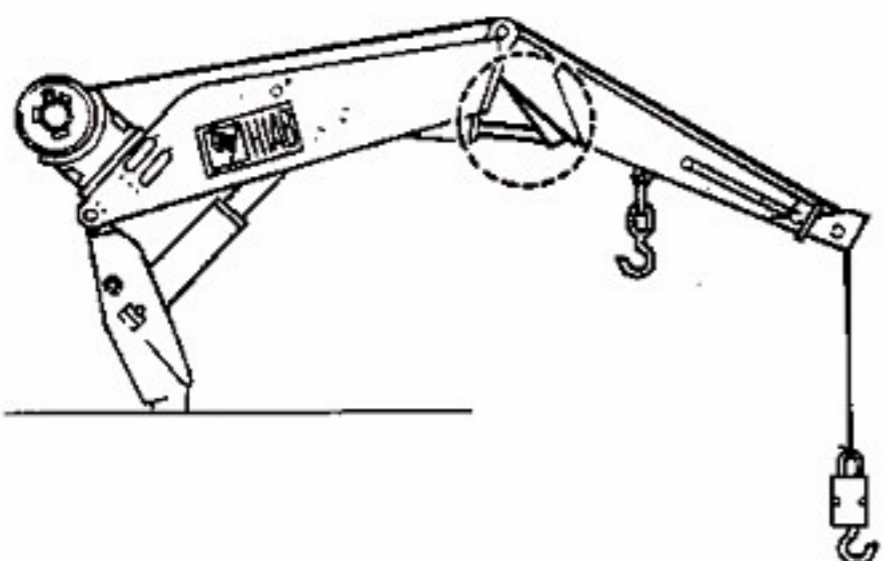
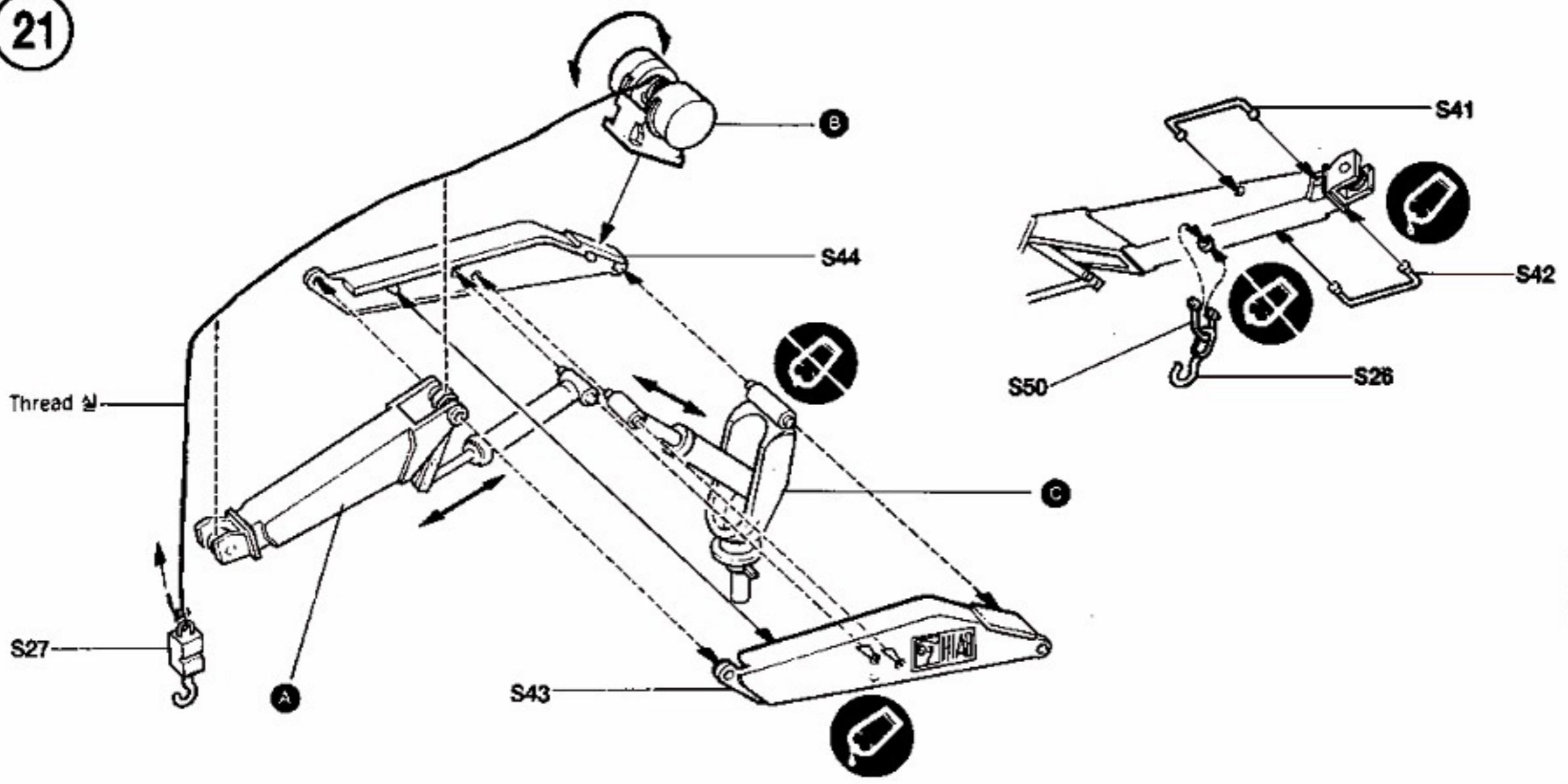

■WORKING POSITION 작업상태

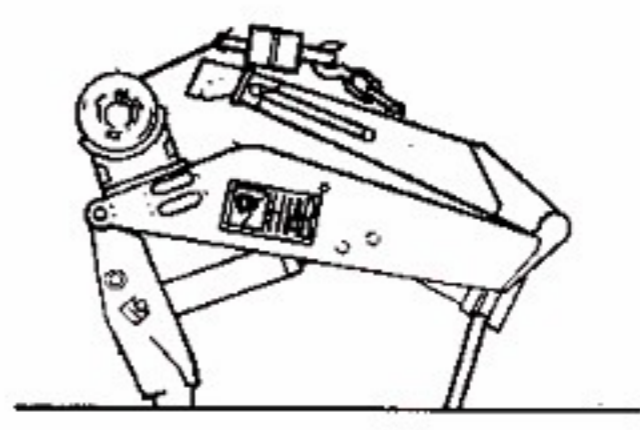

■TRAVELLING POSITION 이동상태

22

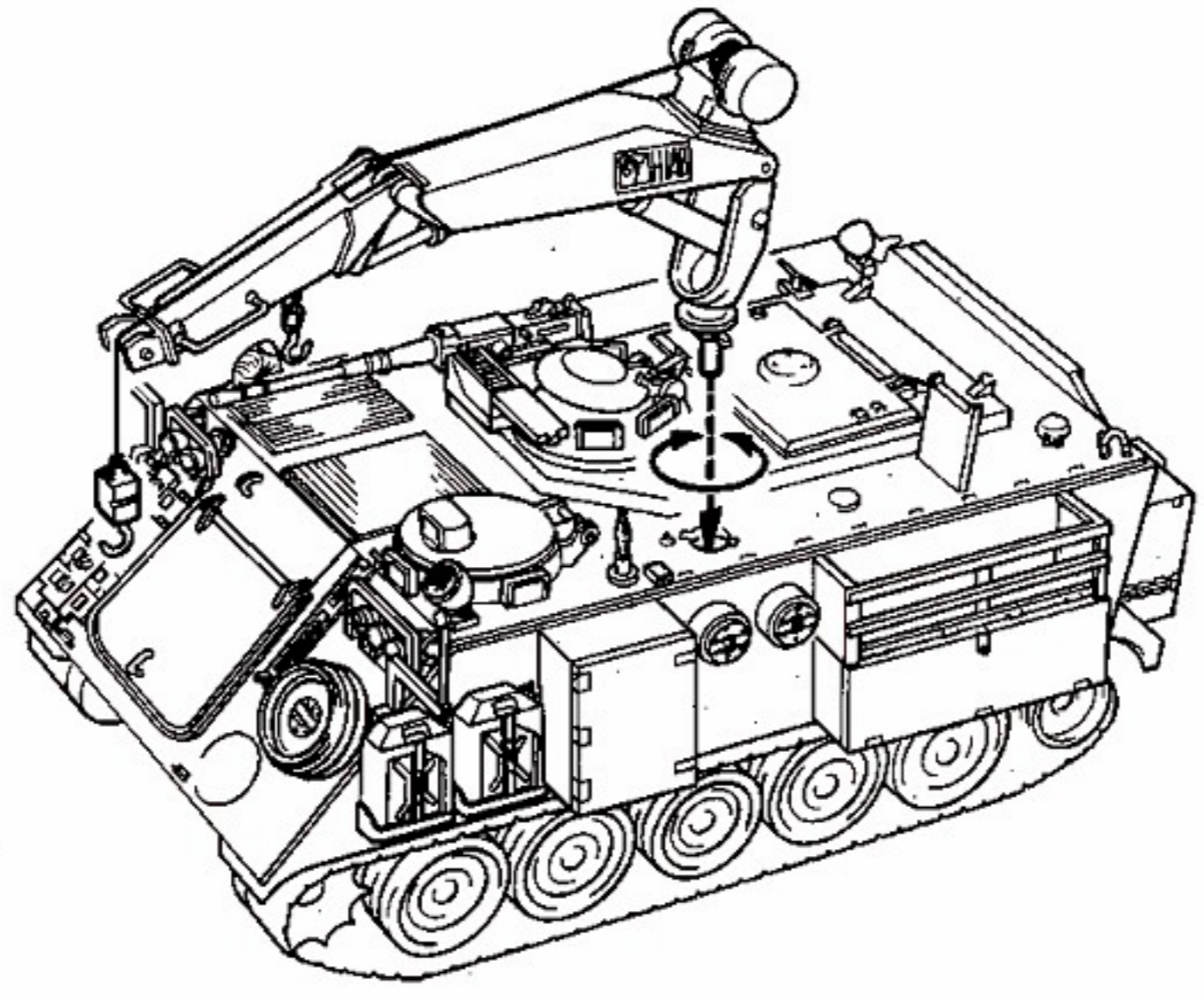

Israeli Defense Force MODERN INFANTRY SET

색칠 (PAINTING)

- ★철모: 국방색 또는 카키색
(Helmet: Olive Drab or Khaki)
- ★각소총, 기관총류: 갈색, 건메탈
(Side Arms: Brown & Gun Metal)
- ★전투화: 무광검정(Boots: Flat Black)
- ★FN-MAG 기관총 탄약지주: 카키색
(Ammo Pouch: Khaki)
- ★배낭, 수통, 군장류: 카키색
(Canteen, Pack-Bags: Khaki)
- ★군복은 카키색(50%)+무광녹색
(50%)을 섞어서 칠한다.
(Uniform: Khaki(50%)+Flat green(50%))

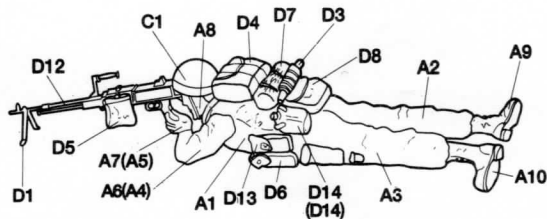
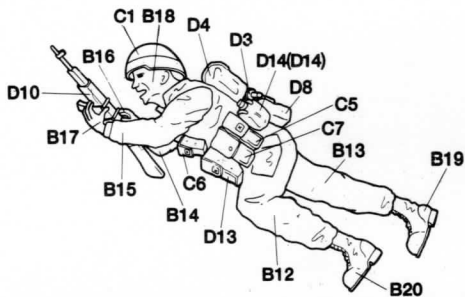
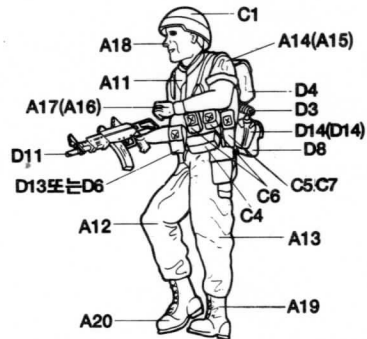
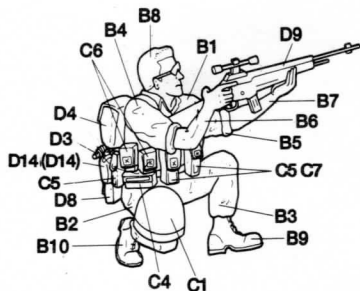

[이스라엘 보병세트의 특징]

- ★이 제품은 1982년 레바논 분쟁에서 현재까지의 이스라엘 육군 보병의 1/35 스케일 축소 인형세트이다.
- ★풍부한 장비류와 총기, 군장을 자유롭게 조립할 수 있다.
- ★가일소총, AK-47, M-21 저격소총, FN-MAG 기관총등 다양한 총기류 포함.

ACADEMY
HOBBY MODEL KITS

ACADEMY PLASTIC MODEL CO., LTD.
273-64, Suyu-dong, Kangbuk-gu, Seoul, Korea
TEL:82-2-908-7000 FAX:82-2-997-3003