

Verwendete Symbole / Used Symbols

Bitte beachten Sie folgende Symbole, die in den nachfolgenden Baustufen verwendet werden.

Veillez noter les symboles indiqués ci-dessous, qui sont utilisés dans les étapes suivantes du montage.

Sívanse tener en cuenta los símbolos facilitados a continuación, a utilizar en las siguientes fases de construcción.

Si prega di fare attenzione ai seguenti simboli che vengono usati nei successivi stadi di costruzione.

Huomoni seuraavat symbolit, jotta käytetään seuraavissa kokoomisvaiheissa.

Legg merke til symbolene som benyttes i monteringsstapene som følger.

Proszę zwrócić na następujące symbole, które są użyte w poniszczonych etapach montażowych.

Daha sonraki montaj basamaklarında kullanılabacak olan, aşağıdaki sembollere lütfen dikkat edin.

Kérjük, hogy a következő szimbólumokat, melyek az alábbi építési fokokban alkalmazásra kerülnek, vegyétek figyelembe.

Please note the following symbols, which are used in the following construction stages.

Neem a.u.b. de volgende symbolen in acht, die in de onderstaande bouwfasen worden gebruikt.

Por favor, preste atenção aos símbolos que seguem pois os mesmos serão usados nas próximas etapas de montagem.

Observera: Nedanstående piktogram används i de följande arbetsmomenten.

Lag vänligt merke til følgende symboler, som benyttes i de følgende byggestadier.

Пожалуйста, обратите внимание на следующие символы, которые используются в последующих операциях сборки.

Παρακαλώ προσέξτε τα παρακάτω σύμβολα, τα οποία χρησιμοποιούνται στις παρακάτω βαθμίδες συναρμολόγησης.

Objezte prosím na dále uvedené symboly, které se používají v následujících konstrukčních stupních.

Prosimo za Vašu pozornost na sledeće simbole ki se uporabljajo v naslednjih korakih gradbe.



Abziehbild in Wasser einweichen und anbringen
Soak and apply decals
Mouiller et appliquer les décalcomanies
Transfer in water even laten weken en aanbrengen
Remojar y aplicar las calcomanías
Pór de molho em água e aplicar o decalque
Immergere in acqua ed applicare decalcomanie
Blöt och läst dekalerna
Kostula siirtokuvaa vedessä ja aseta paikalteen
Overføringsbilledet lægges i blød og anbringes
Dypp bildet i vann og sett det på
Переводничку картички намочить и нанести
Złpićczyć kalkomanie w wodzie a następnie nakleić
βουτήξτε τη χαλκομανία στο νερό και τοποθετήστε την
Çikartmayı suda yumuşatın ve koyun
Óbtisk namočit ve vodě a umístit
A matricát vizben beáztatni és felhelyezni
Preslikać potopiti v vodo in zatem nanašati



Kleben
Glue
Coller
Lijmen
Engomar
Colar
Incollare
Limmas
Limaa
Klæbning
Lim
Клеить
Przykleić
κόλλημα
Yapıştırma
Lepeni
ragasztani
Lepiti



Nicht kleben
Don't glue
Ne pas coller
Niet lijmen
No engomar
Não colar
Non incollare
Limmas ej
Älä limaa
Må ikke klæbes
Ikke lim
Не клеить
Nie przyklejać
μη κολλάτε
Yapıştırmayın
Nelepit
nem szabad ragasztani
Ne lepiti



Wahlweise
Optional
Facultatif
Naar keuze
No engomar
Alternado
Facoltativo
Valfritt
Valitohetoisesti
Eter eget valg
Valgfritt
Do wyboru
εναλλακτικά
Seçmeli
Voliteľné
tetszés szerint
način izbire



Anzahl der Arbeitsgänge
Number of working steps
Nombre d'étapes de travail
Het aantal bouwstappen
Número de operaciones de trabajo
Número de etapas de trabalho
Numero di passaggi
Antal arbetsmoment
Työvaiheiden lukumäärä
Antal arbetsförlopp
Antall arbeidstrinn
Количество операций
Liczba operacji
αριθμός των εργασιών
İş safhalarının sayısı
Počet pracovnich operáci
Munkafolyamatok száma
Številka koraka montaže



Gleichen Vorgang auf der gegenüberliegenden Seite wiederholen
Repeat same procedure on opposite side
Opérer de la même façon sur l'autre face
Dezelfde handeling herhalen aan de tegenoverliggende kant
Realizar el mismo procedimiento en el lado opuesto
Repetir o mesmo procedimento utilizado no lado oposto
Stessa procedura sul lato opposto
Upprepa proceduren på motsatta sidan
Toista sama toimenpide kuten vierreisellä sivulla
Det samme arbejdet gentages på den modsatliggende side
Gjentla prosedyren på siden lvers overfor
Повторять такую же операцию на противоположной стороне
Taki sam przebieg czynności powtórzyc na stronie przeciwnej
επαναλάβετε την ίδια διαδικασία στην απέναντι πλευρά
Αynı işlemi karşı tarafta tekrarlayın
Stejný postup zopakovat na protilehlé straně

ugyanazt a folyamatot a szemben található oldalon megismételni
Isti postopek ponoviti in na suprotni strani



Abbildung zusammengesetzter Teile
Illustration of assembled parts
Figure représentant les pièces assemblées
Afbeelding van samengevoegde onderdelen
Ilustración piezas ensambladas
Figura representando peças encaixadas
Illustrazione delle parti assemblate
Bildn visar dalarna hopsatta
Kuva yhteenlittetyistä osista
Illustration af sammensatte dele
Illustrasjon, sammensatte deler
Изображение смонтированных деталей
Fysunek złożonych części
απεικόνιση των συναρμολογημένων εξαρτημάτων
Birleştirilen parçaların şekli
Zobrazeni sestavených dílů
összeállított alkatrészek ábrája
Slika slopljenega dela

Benötigte Farben / Used Colors

Benötigte Farben Required colours	Peintures nécessaires Benötigde Kleuren	Pinturas necesarias Tintas necessárias	Colori necessari Använda färger	Tarvittavat värit Nødvendige farver	Nødvendige färger Необходимые краски	Potrzebne kolory Απαιτούμενα χρώματα	Gerekli renkler Potřebné barvy	Szükséges színek. Potrebne barve
A	B	C	D	E	F	G		
bronzegrün, matt 65 bronze green, matt vert bronze, mat bronzegroen, mat verde bronceado, mate verde bronze, fosco verde bronzo, opaco bronzgrön, matt pronsisvihreä, himmeä bronzegrön, mat bronzegränn, matt бронзово-зеленый, матовый brązowozielony, matowy πράσινο μπρούτζου, ματ bronz yeşilli, mat bronzové zelená, matná bronzöld, matt bronz zelena, mat	lederbraun, matt 84 leather brown, matt brun cuir, mat lederbruin, mat marrón cuero, mate castanho couro, fosco marrone couio, opaco läderbrun, matt nahkanruskea, himmeä läderbrun, mat läderbrun, matt коричневая кожа, матовый brunatny jak skóra, matowy καφέ δέρματος, ματ deri kahverengi, mat kožená hnědá, matná bőrbarna, matt koža rjava, mat	teerswarz, matt 6 tar black, matt noir tarte, mat teerzwart, mat negro alquitrán, mate alcatrão, fosco nero calame, opaco asfaltswart, matt tervanmusta, himmeä tjæresort, mat tjæresort, matt смолисто-черный, матовый czarny-smola, matowy μαύρο πίσος, ματ kaltran siyah, mat dehtové černá, matná kátrányfekete, matt ter črna, mat	ocker, matt 88 ochre brown, matt ocre, mat oker, mat ocre, mate ocre, fosco ocra, opaco ockra, matt okra (keltamulta), himmeä ockker, mat oker, matt охра, матовый oczary, matowy óçra, mat koyu kavuniçi, mat okrově žlutá, matná okker, matt oker, mat	anthrazit, matt 9 anthracite grey, matt anthracite, mat antraciet, mat antracita, mate antracite, fosco antracite, opaco antracit, matt antrasitti, himmeä koksgrå, mat antrasit, matt антрацит, матовый antracyt, matowy ανθρακί, ματ antrasit, mat antracit, matná antracit, matt tamno siva, mat	silber, metallic 90 silver, metallic argent, métallique zilver, metallic plata, metalizado prata, metálico argento, metálico silver, metallic hopea, metallikiilto salv, metallic salv, metallic серебристый, металл srebro, metaliczny σημί, μεταλλικό gümüş, metalik stříbrná, metaliza ezüst, metál srebrna, metalik	ferroet, glänzend 31 fiery red, gloss rouge feu, brillant rood helder, brillant rosso luoco, lucente vermelho vivo, brilhante tulipunainen, kiiltävä ildrød, skinnende ildrød, blank огненно-красный, блестящий szeryony ognisty, blyszczący κόκκινο φωτιάς, γυαλιστερό ateş kırmızısı, parlak ohnivě červená, lesklá tűzpiros, fényes ogjen rdeča, bleskajoča		
H	I	J	80%	K	20%			
rost, matt 83 rust, matt rouille, mat roest, mat orin, mate ferrugem, fosco color ruggine, opaco rost, matt ruste, himmeä rust, mat rust, matt ржавчина, матовый rdzawy, matowy χρώμα σκουριάς, ματ pas rengi, mat rezavá, matná rozsdá, matt rjava, mat	schwarz, glänzend 7 black, gloss noir, brillant zwart, glansend negro, brillante preto, brilhante nero, lucente svart, blank musta, kiiltävä sort, skinnende sort, blank черный, блестящий czarny, blyszczący μαύρο, γυαλιστερό siyah, parlak černá, lesklá fekete, fényes črna, bleskajoča	schwarz, matt 8 black, matt noir, mat zwart, mat negro, mate preto, fosco nero, opaco svart, matt musta, himmeä sort, mat sort, matt черный, матовый czarny, matowy μαύρο, ματ siyah, mat černá, matná fekete, matt črna, mat	schwarz, glänzend 7 black, gloss noir, brillant zwart, glansend negro, brillante preto, brilhante nero, lucente svart, blank musta, kiiltävä sort, skinnende sort, blank черный, блестящий czarny, blyszczący μαύρο, γυαλιστερό siyah, parlak černá, lesklá fekete, fényes črna, bleskajoča	+	eisen, metallic 91 steel, metallic coloris fer, métallique ijzerkleurig, metallic ferroso, metalizado ferro, metálico ferro, metalico järnårg, metallic teräksenvärinen, metallikiilto jern, metalik jern, metalik стальной, металл żelazo, metaliczny σιδηρού, μεταλλικό demir, metalik železná, metaliza vas, metál železna, metalik			

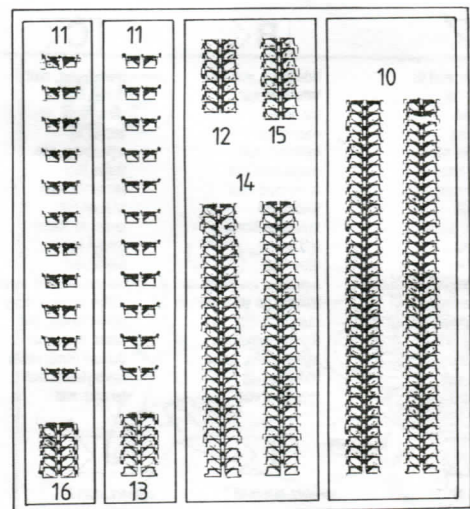
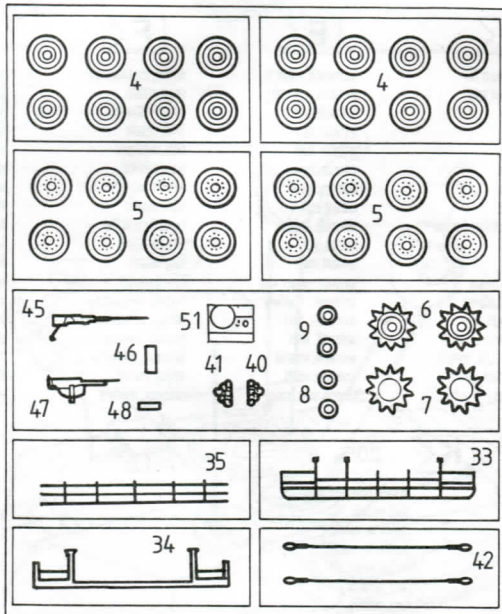
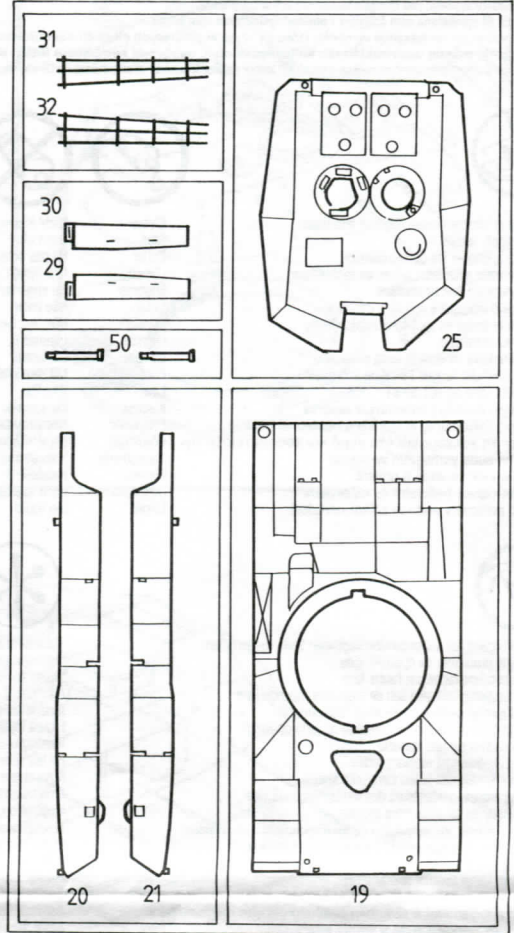
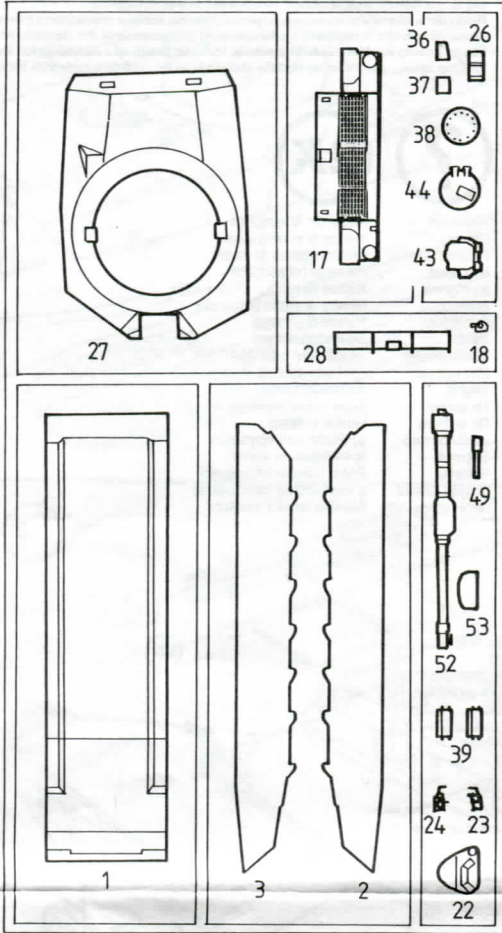

1 

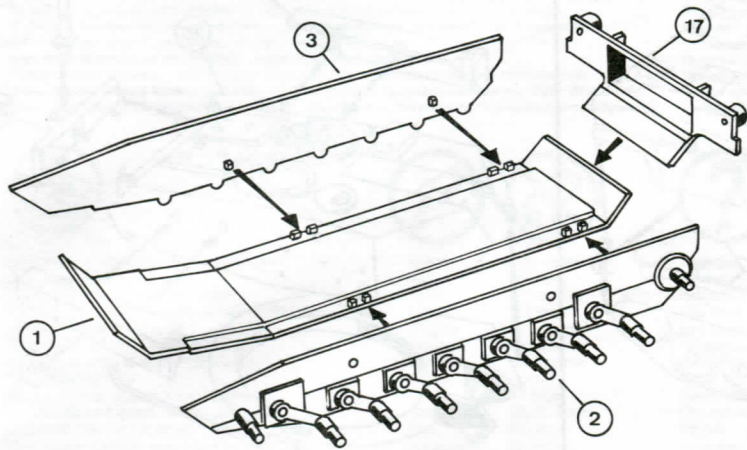

2 

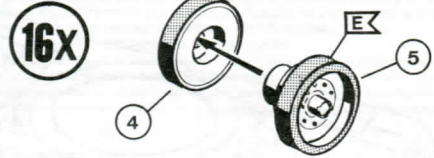

3 

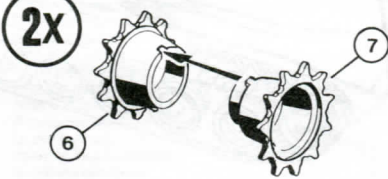

4 

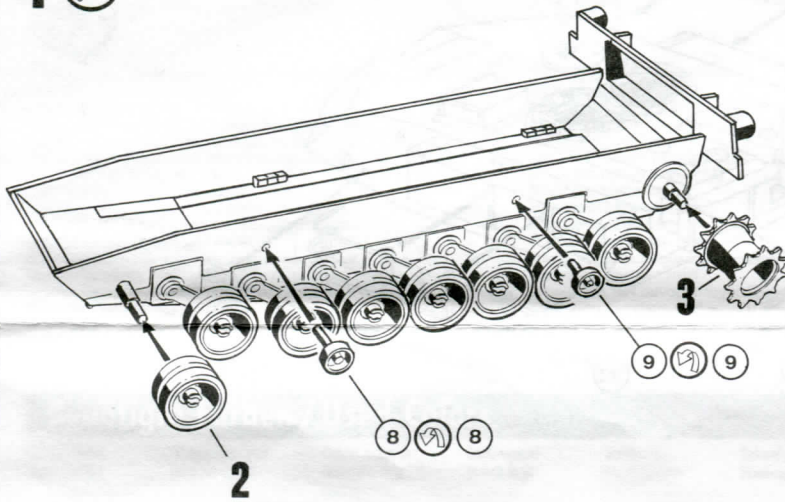

5 

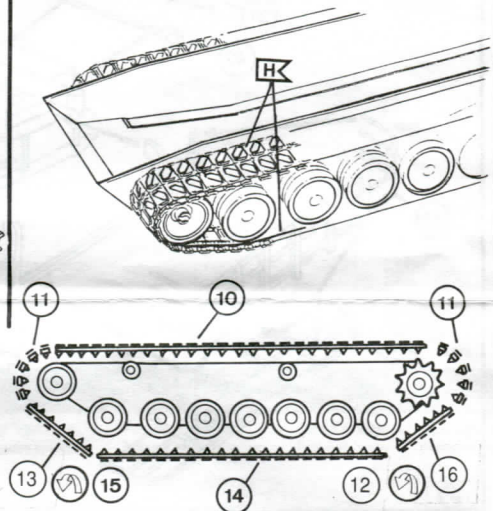

6 

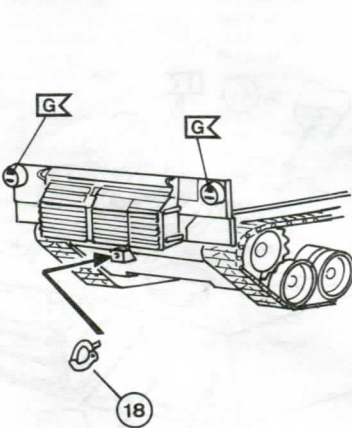

7 

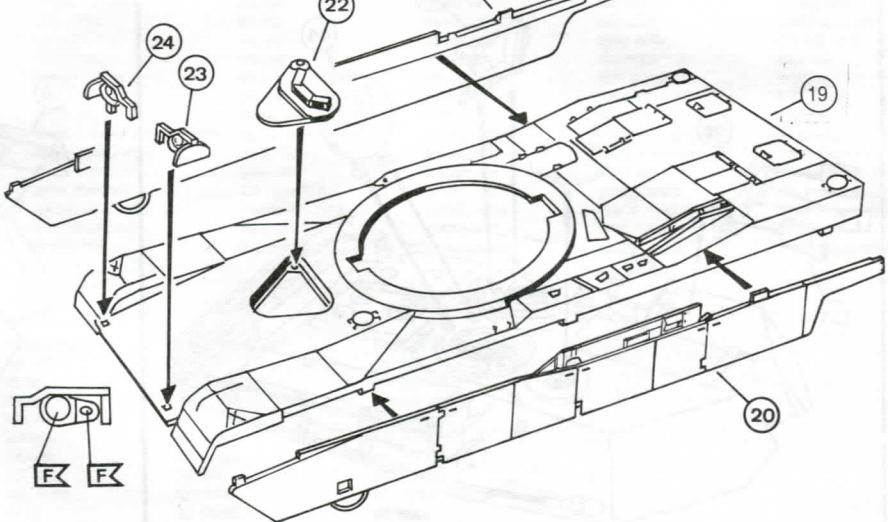

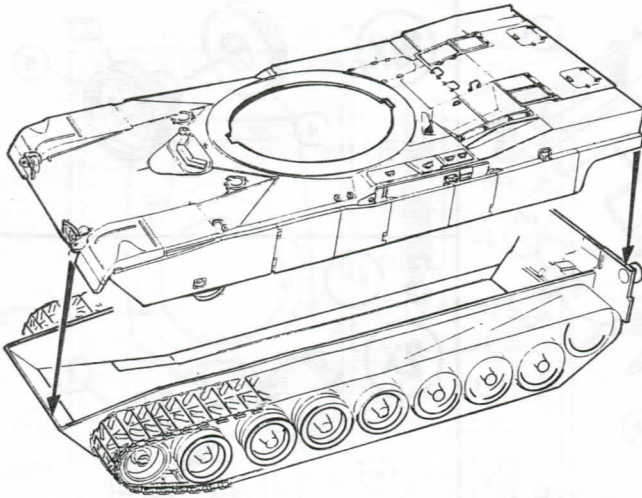
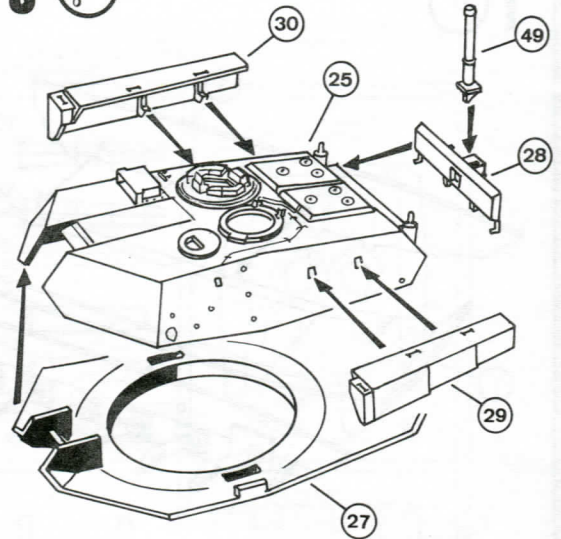
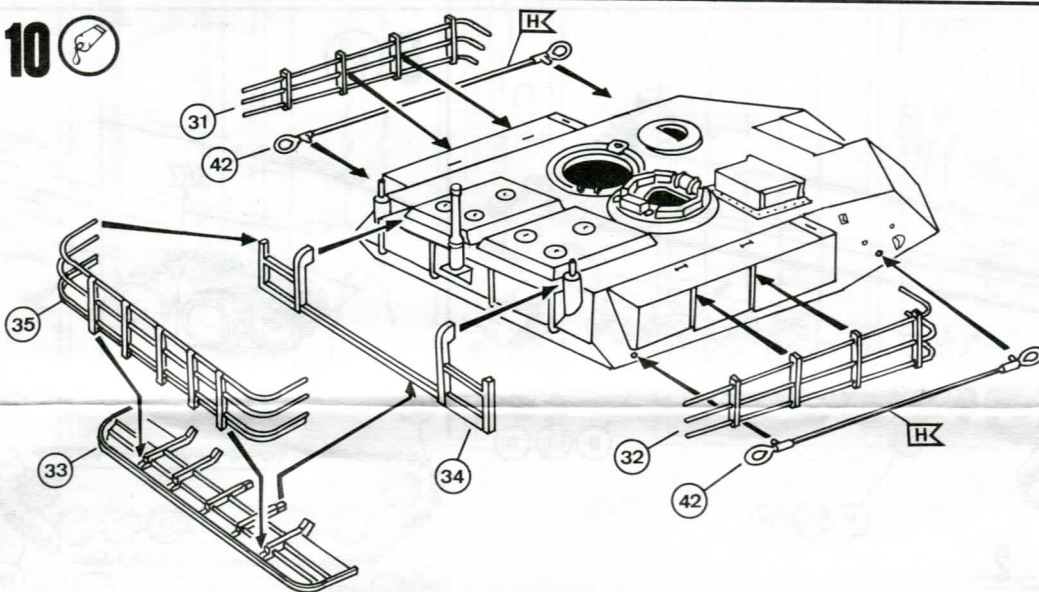
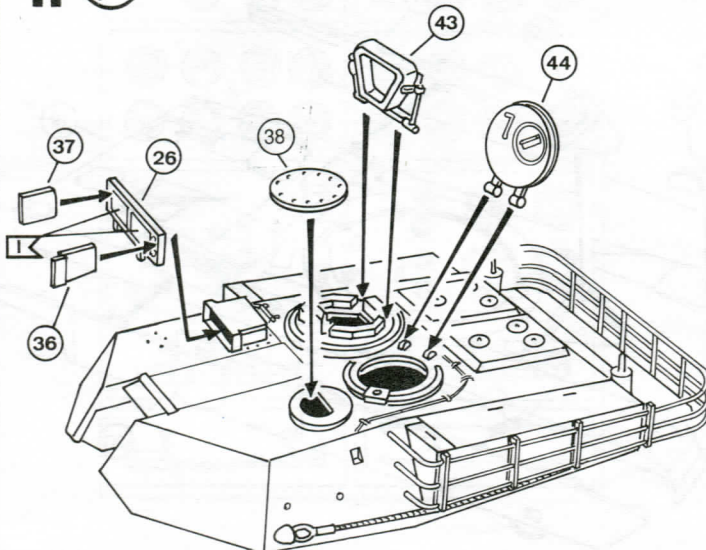
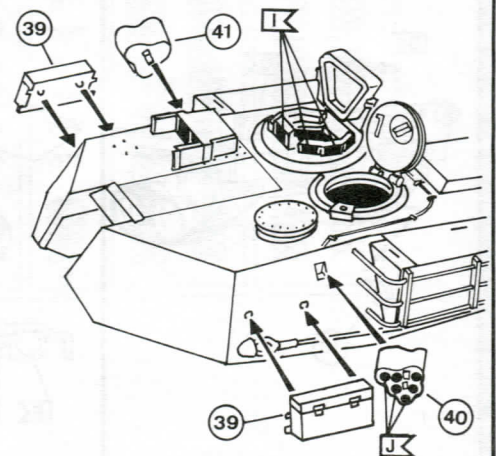
8 9 10 11 12 

13

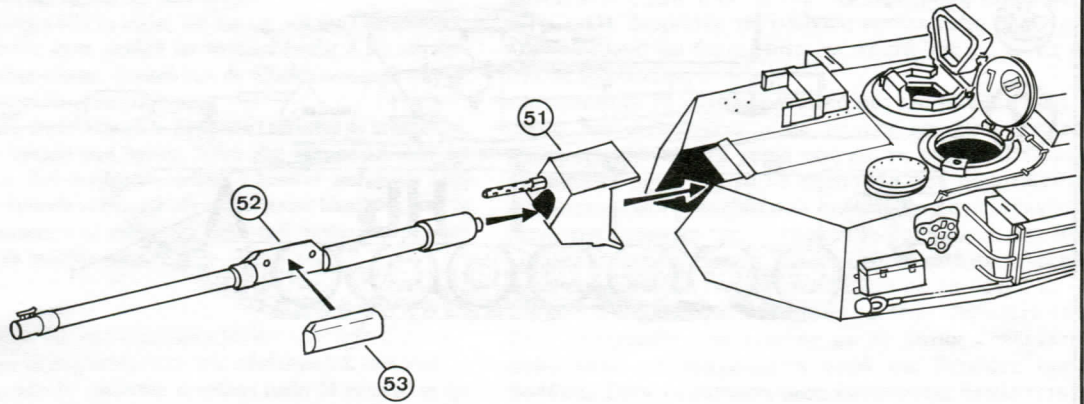

14

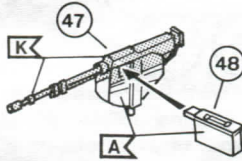

16

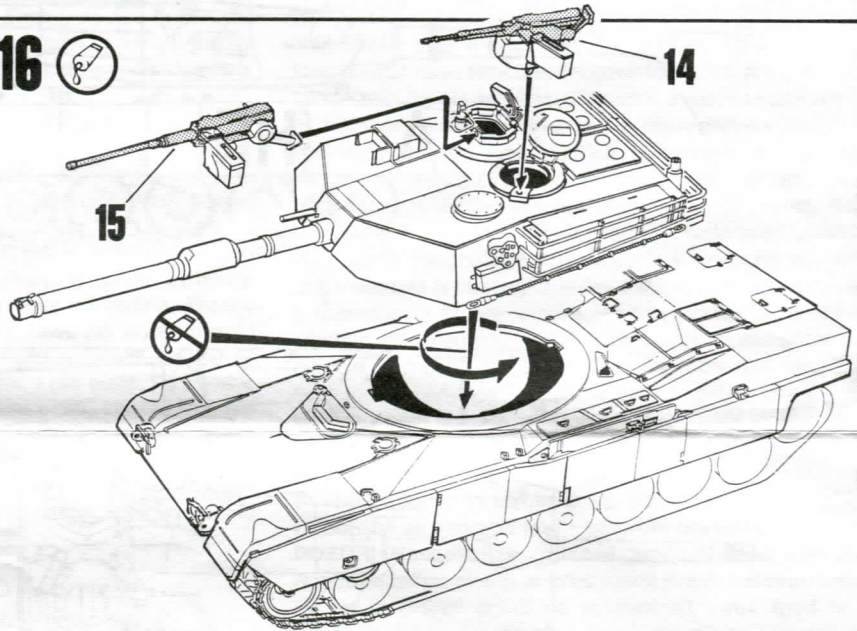

15

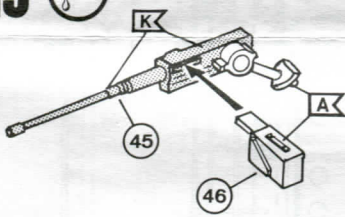

17

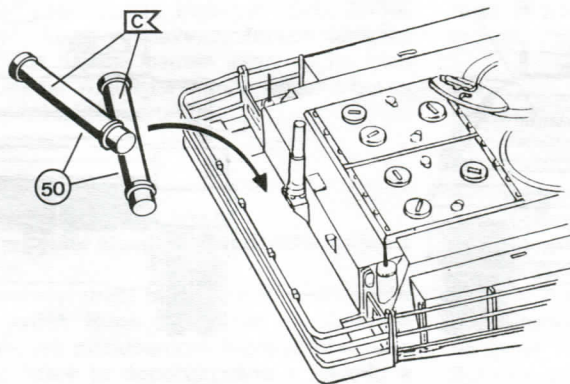

18

AV H6 H6

AV	H6	H6
AV	H6	H6
AV	H6	H6
AV	H6	H6

AVH6A 03112 0240 D
AVH6A 03112 0240 D

3rd Armored Cavalry Regiment Desert Storm

