

I.A.I KFIR C2

1/72 Scale Series

KIT No. JS-149

י.א.י. כפיר C2



HASEGAWA



IAI KFIR C-2 HISTORY

Relying on the French aircraft industry for the bulk of its military aircraft, Israel built its air force around the Dassault Mirage III, which it used to good advantage during the now famous "Six Day War" in 1967. The Israelis were delighted with the performance of Mirage III and ordered the more advanced -5 attack version, which was built to their specifications. However, the French government refused to let Dassault deliver the Mirage 5's to Israel, forcing the Israelis to develop and manufacture their own machines. The first planes were virtually carbon copies of the favored Mirage 5 design, and the Israelis named them "Nesher", or Eagle.

The Nesher was powered by the same type of engine used in the original Mirage series, but early

in 1970, the more powerful General Electric J79 became available to the Israeli engineers. This led to an extensive redesign of the Nesher to accommodate the American engine. The combination proved a perfect marriage and the Kfir (Lion Cub) was created. By 1975, Kfirs were filling the ranks of Israel's air force, the Heyl Ha' Avir. The Kfir C-2 features canard-like foreplanes to enhance its maneuverability and distinguishes it from the earlier models.

Although still somewhat shrouded in secrecy, it is known that the Kfirs carry the latest electronic flight control systems (Fly by wire) and advanced radar gear, making it one of the most formidable fighters and ground attack planes in the air today. And to top that off, it is the lowest priced fighter in production, with a tag of about four million dollars.

This feature alone has attracted the attention of

several smaller air forces throughout the free world which are seeking a first-line fighter at an affordable price. And they would be acquiring one of the finest fighters in the world!

IAI KFIR C-2 CHARACTERISTICS

- Dimensions: Wingspan - 27 feet
Length - 54 feet
- Powerplant: One General Electric J79-17 turbojet engine of 17,900 lbs thrust with afterburning.
- Performance: Maximum speed - 1,550 mph (Mach 2.35)
Service Ceiling - 55,000 feet
- Armament: Two 30mm DEFA 553 cannons, two Shafrir air-to-air missiles (Similar to U.S. Sidewinder).

Marking & Color Painting Guide

1 Israeli Air Force

- 7 Clear red
- 12 Mahogany



2 At paris Air Show 1977

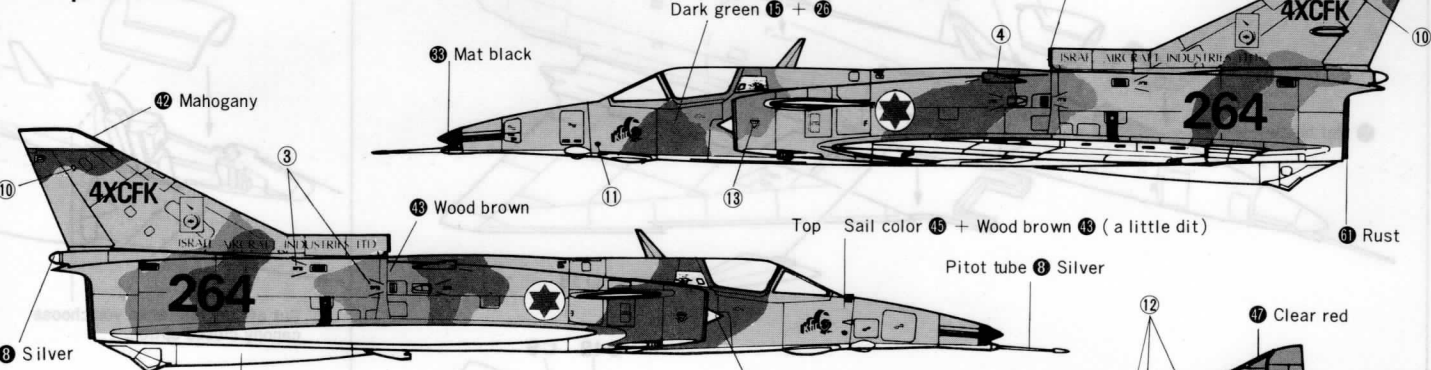

Top & Bottom view of 1

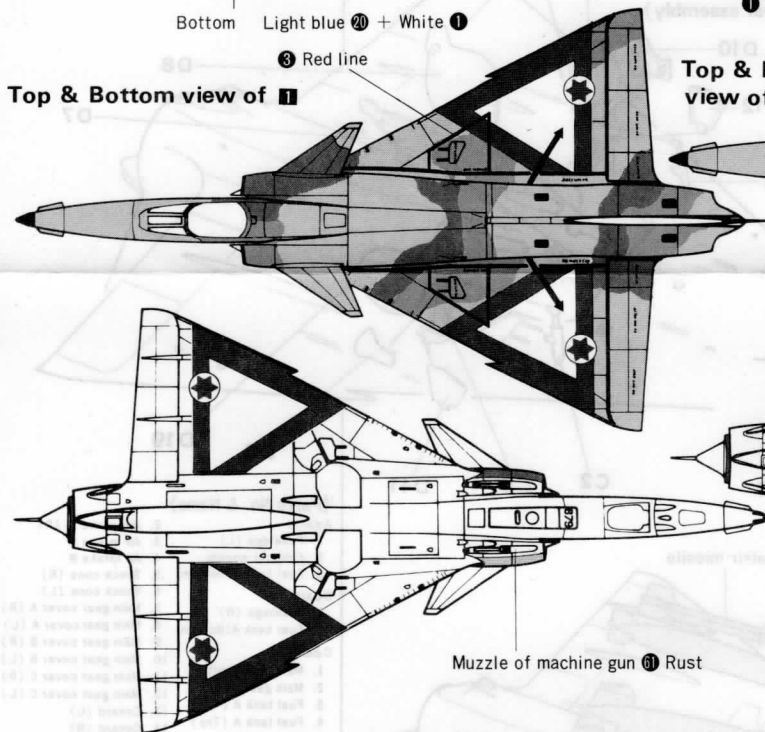

Top & Bottom view of 2

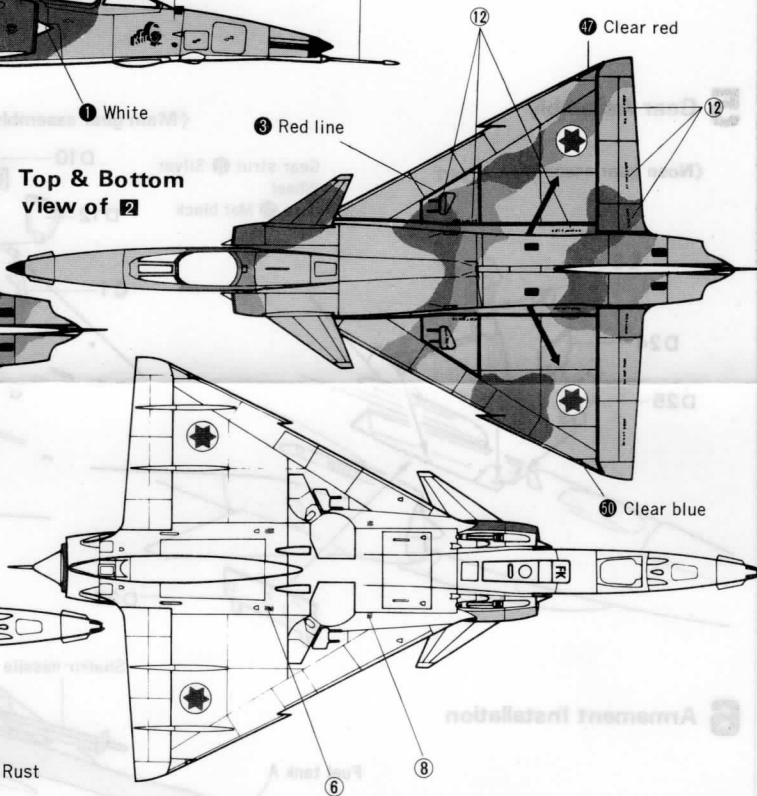

Color Painting of KFIR C-2

Kfir C-2 is camouflaged with yellow, tan and green in mat finish just the same as the other Israeli Air Force planes. The border line of each color is vaguely sprayed. Line on the main wing and front edge of air-intake in front of vertical tail are red. Front edge of vertical tail top is supposed to be very dark brown. Pitot tube and drag shoot cover are supposed to be silver and the bottom of fuselage seems to be partially painted in silver, too. Tip of nose and the swelling under nose Israeli Air Force operational version are mat black.

HOW TO APPLY DECALS

1. Cut out the decal and remove the film covering. Place it in water for 20 seconds.
2. Slide slightly the decal on the paste-board.
3. Press the decal with a soft cloth and remove the moisture and surplus adhesive.

MODEL COLORS

Model Colors are numbered. After assembling, be sure to paint the model in order to enhance your workmanship. As to paint tiny parts, use a profile brush, and paint wide area, use a flat brush.

1 Cockpit Assembly

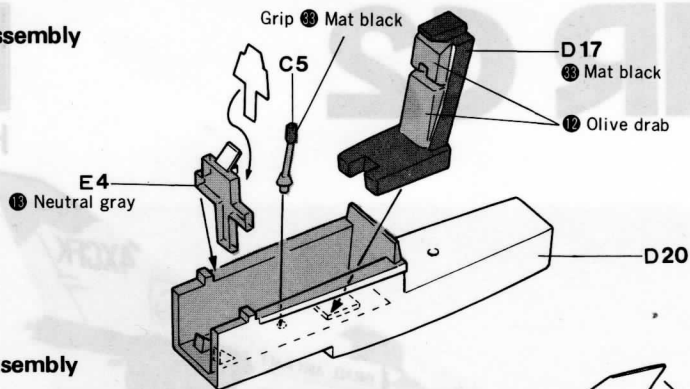

2 Fuselage Assembly

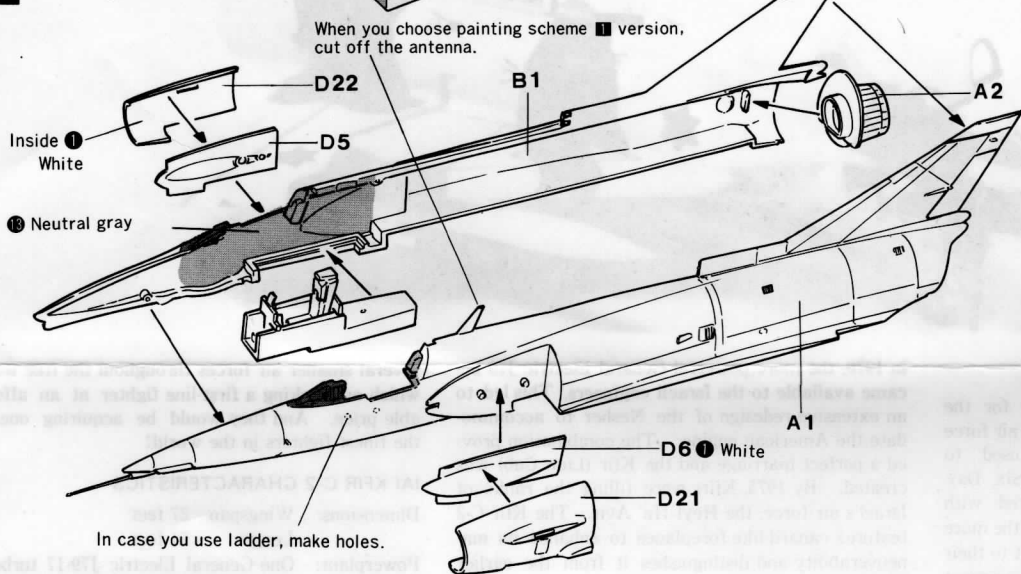

3 Main Wing Assembly

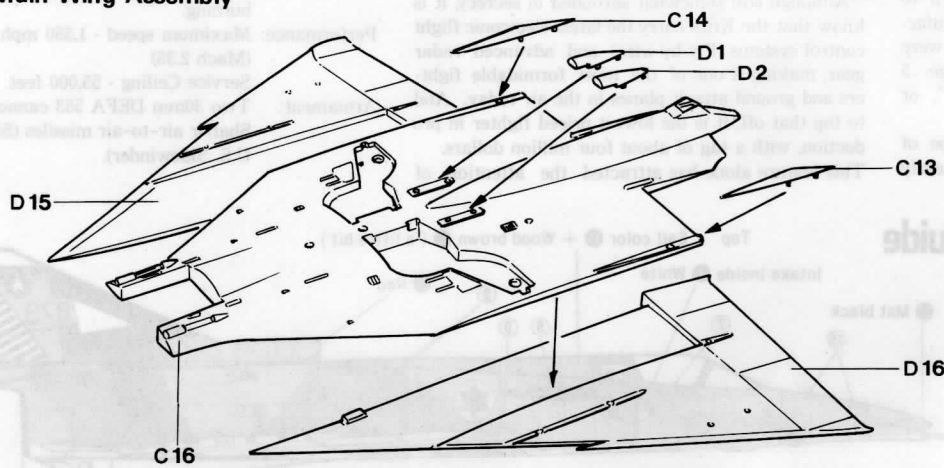

4 Main Wing Installation

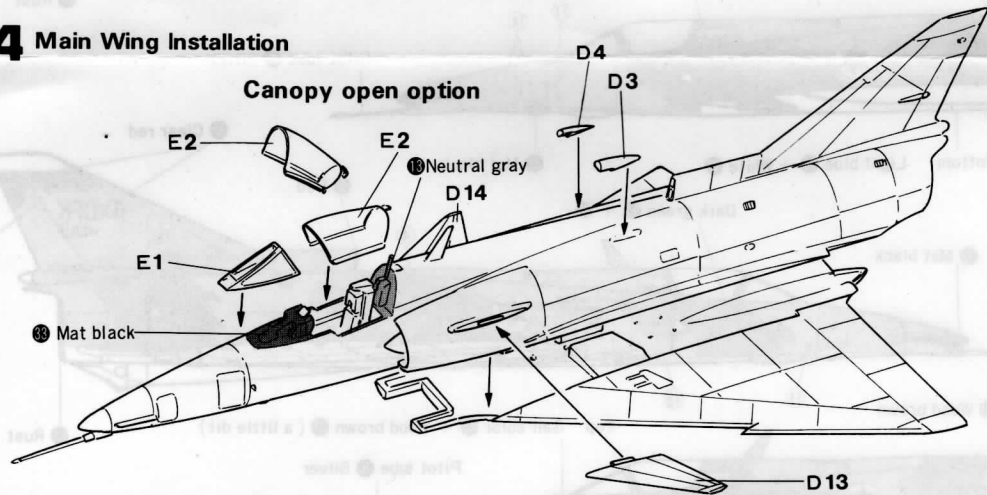

5 Gear Assembly

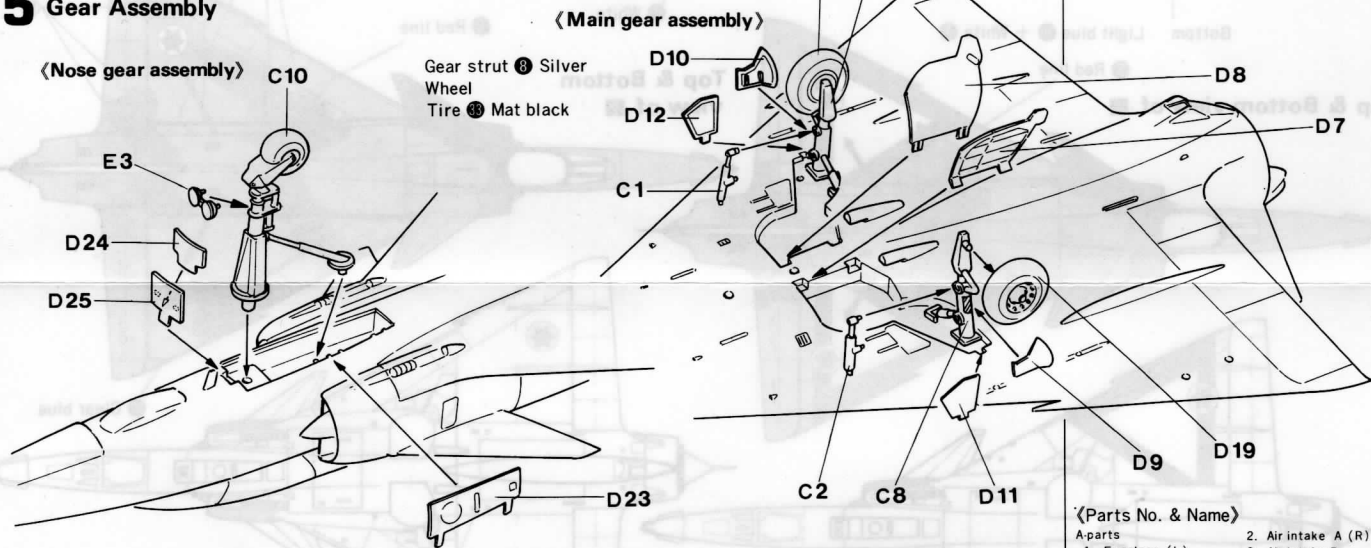

6 Armament Installation

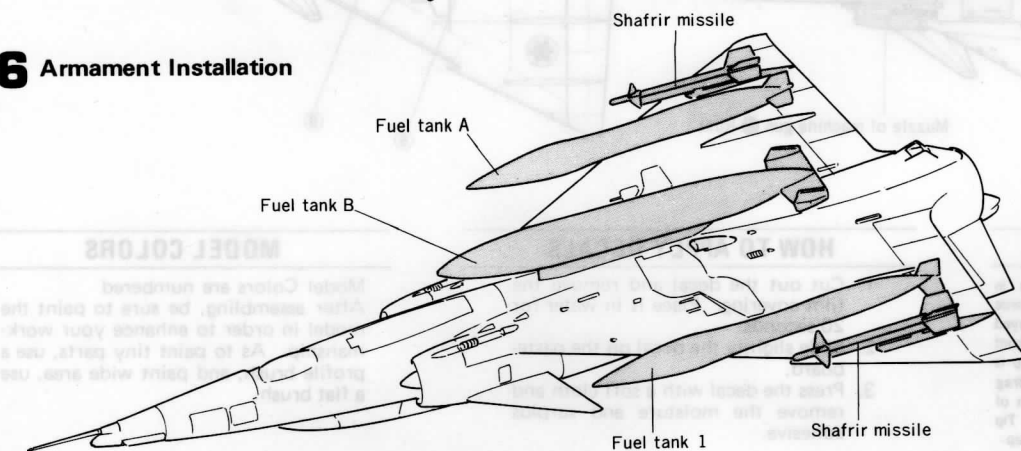

★ Before assembling

- Follow the instructions carefully.
- Cut off the parts from the stem with a nipper or cutter.
- When using adhesive, apply it to both parts to be cemented. Please take care not to apply too much adhesive.
- Pay attention to proper fitting of each parts using cello-tape before cementing the parts.

★ MODEL COLOR

The number ①-⑦ mean Model Color number. Let's make the beautiful air-planes with color painting!

■ Armament Assembly

Fuel tank A assembly

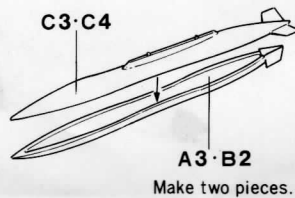

Fuel tank B assembly

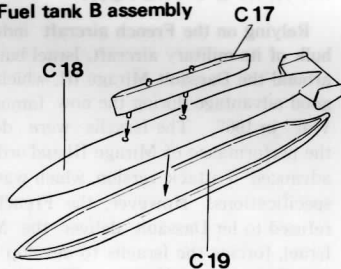

■ Shafrir Missile Assembly

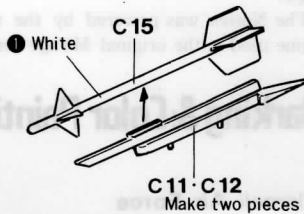

■ Ladder Assembly

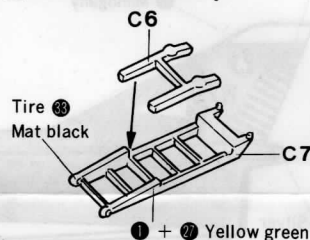

■ Canopy Closed Option Assembly

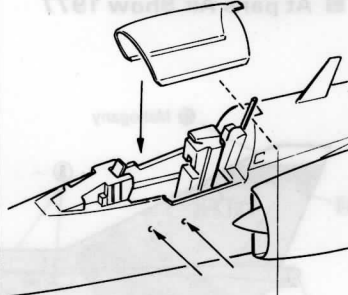

Cut off the pin, when you choose canopy closed option.

《Parts No. & Name》

- | | |
|--------------------------|---------------------------|
| A-parts | |
| 1. Fuselage (L) | 2. Air intake A (R) |
| 2. Fuselage (R) | 3. Air intake B |
| 3. Exhaust nozzle | 4. Air intake C (L) |
| 4. Fuel tank A (Bottom) | 5. Shock cone (R) |
| 5. Fuel tank A (Top) | 6. Shock cone (L) |
| B-parts | |
| 1. Main gear (R) | 7. Main gear cover A (R) |
| 2. Main gear (L) | 8. Main gear cover A (L) |
| 3. Main gear (R) | 9. Main gear cover B (R) |
| 4. Main gear (L) | 10. Main gear cover B (L) |
| 5. Main gear (R) | 11. Main gear cover C (R) |
| 6. Main gear (L) | 12. Main gear cover C (L) |
| C-parts | |
| 1. Main gear strut | 13. Canard (L) |
| 2. Main gear strut | 14. Canard (R) |
| 3. Fuel tank A (Top) | 15. Main wing top (L) |
| 4. Fuel tank A (Bottom) | 16. Main wing top (R) |
| 5. Control stick | 17. Ladder (A) |
| 6. Ladder (B) | 18. Seat |
| 7. Ladder (C) | 19. Main wheel |
| 8. Main gear (R) | 20. Main wheel |
| 9. Main gear (L) | 21. Cockpit floor |
| 10. Nose gear | 22. Air intake C (L) |
| 11. Pylon (A) | 23. Air intake C (R) |
| 12. Pylon (B) | 24. Nose gear cover A |
| 13. Flap hinge | 25. Nose gear cover B |
| 14. Flap hinge | 26. Nose gear cover C |
| 15. Shafrir missile | |
| 16. Main wing bottom | |
| 17. Pylon (B) | |
| 18. Fuel tank B (Top) | |
| 19. Fuel tank B (Bottom) | |
| E-parts | |
| 1. Front canopy | |
| 2. Rear canopy | |
| D-parts | |
| 1. Air intake A (L) | 4. Instrument panel |