

# Peška/Peshka

eduard

## RUSSIAN WWII BOMBER

### 1/48 SCALE PLASTIC KIT

# #11112



DECALS DESIGNED BY

 Begemot

## INTRO

The birth of this most numerous Russian twin engine aircraft of WW II started in an awkward manner - in prison. Better to say in so called "sharashka" (NKVDs' prison No. 100 in Bolshino), where imprisoned aircraft designers (mainly from TsAGI - The Central Aerodynamic Institute) were concentrated upon the charges of sabotage and espionage. Vladimir Mikhailovich Petlyakov was one of them. Prior to his arrestment he worked as the Chief Designer on the TB-7, four engined heavy bomber, but NKVD officials suspected the design process was slowed down deliberately and Petlyakov arrested. Two years later was moved into the sharashka with a task to develop high altitude twin engined fighter intended as the escort of the TB-7s. The prototype got designation VI-100, but, just before approval of the serial production, Petlyakov was ordered to redesign the plane for a dive bomber at the end of May 1940 with very short deadline for the mock-up of PB-100 to be ready for inspection on September 1st, 1940. Petlyakov reworked VI-100 into the PB-100 (PB stands for Dive bomber in Russian). The pressurized cabin was gone, canopy shortened, new main bomb bay for four 220 lb bombs was created in the fuselage, two bomb bays were added to the back of the reworked engine nacelles (each for one 220 lb bomb). Up to four 550 lb bombs added to the full payload on the external bomb racks. To slow the dive, the wings were equipped with aerodynamic brakes. The PB-100 prototype made its maiden flight on December 15th, 1940 and was impressive enough to win the mercy for Petlyakov who not only was released, but even honored with naming the aircraft after him. The Pe-2 was rushed into production and deliveries to combat units began in the Spring of 1941.

### Fast "on paper"

In the middle of 1941 units had nearly 500 of new Pe-2s, but, due to the rushed design process and fast pre-production preparations, the problems started to arise. True, the Pe-2 was quite fast, the first prototype achieved 360 mph at 13 100 ft and, thanks to the turbocharged engines, some 373 mph at 23 000 ft. The speeds were match to the German Bf 109E fighter, but... Production planes (produced in factories No. 22 and No. 39) were of much lower craftsmanship quality than prototype and the engines Klimov M-105 had less effective mechanical compressors instead turbochargers. More to it, as Pe-2 had to carry the main payload as external stores, it added to drag significantly. All of this led to the drop of the real maximum speed and, as the first combat experience proved, the Pe-2 was not fast enough to operate without the fighter escort. Also defensive armament consisting of four ShKAS 7,62 mm machine guns (two operated rearward firing and two fixed forward firing) was rather weak. Petlyakov died on January 12th, 1942 when travelling in second production Pe-2 to Moscow, so the further development of Pe-2 was shortly in hands of less experienced A.M. Izacson, who was replaced in 1943 by A. I. Putilov and later, at the end of that year by V. M. Myasishev.

### Birth of FT

The changes started with series 13. The starboard fixed 7,62 mm ShKAS was replaced with more powerful 12,7 mm UBS and the same change was done at the lower firepost. The series 22 featured more powerful M-105RA engines rated at 1100 hp and starting from series 83 the TSS-1 gun mount with ShKAS 7,62 mm operated by bomber/navigator was replaced with 12,7 mm UBT machine gun. The change for new weapon necessitated deletion of rear canopy glazing and also a new mount. As the frontline pilots required such a change, the new mount was, rather unofficially, named FT as abbreviation of "frontovoye trebovanie" (frontline needs). The new FT mount was then produced also as a kit for converting existing Pe-2s. Some 1010 of them were produced for apart from those supplied for new series 83 Pe-2s, also sporting new front nose glazing with side windows deleted. The FT mount with open canopy was considered as an interim solution. The final arrangement was made by installation of new VUB-1 closed turret which bettered field of fire. On the other side the turret lowered the speed of plane by some 12 km/h. The first series receiving VUB-1 was 110 in June 1942, considered as a first "real" Pe-2FT version, although officially the PF designation was not used.

### Battle for speed

Drop in quality of production led to the drop of the performance. The maximum speed of series 95 was only 303 mph in summer of 1942. The weight and drag were growing and so were combat losses. The need for further development was obvious. Apart of several try outs with different engines and planned Pe-2F version with repositioned wing, the real redesign started only after the TsAGI was able to restore their activities in Moscow in 1943. First of all, more powerful M-105PF engine with 1210 hp was used for series 179. There were also numerous small aerodynamic changes. The performance was growing again and series 205 with redesigned engine front cowling was reaching 324 mph at 12 140 ft in March 1943. The last production series is represented by series 359 with revised radio operator windshield, changed exhaust and some internal changes like new oxygen system. The series 359 was kept in production without changes to the end of the war and supplied also to the Polish or Czechoslovak units and exported after the war to other countries. Apart of the series 115 with wooden back section of the fuselage, the Pe-2 was of all metal construction with fabric cover of the control surfaces. Some 11 070 examples were built, mainly in factory No. 22.



Carefully read instruction sheet before assembling. When you use glue or paint, do not use near open flame and use in well ventilated room. Keep out of reach of small children. Children must not be allowed to suck any part, or pull vinyl bag over the head.



Před započítím stavby si pečlivě prostudujte stavební návod. Při používání barev a lepidla pracujte v dobře větrané místnosti. Lepidla ani barvy nepoužívejte v blízkosti otevřeného ohně. Model není určen malým dětem, mohlo by dojít k požití drobných dílů.



OPTIONAL  
VOLBA



BEND  
OHNOUT



OPEN HOLE  
VYVRTAT OTVOR



SYMMETRICAL ASSEMBLY  
SYMETRICKÁ MONTÁŽ



REMOVE  
ODŘÍZNOUT



REVERSE SIDE  
OTOČIT



APPLY EDUARD MASK  
AND PAINT  
POUŽÍT EDUARD MASK  
NABARVIT



## PLASTIC PARTS

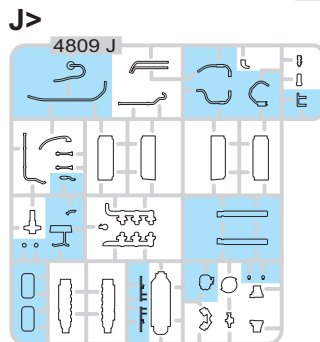
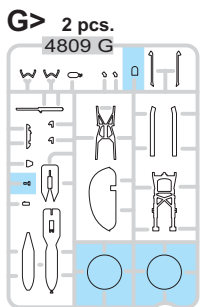
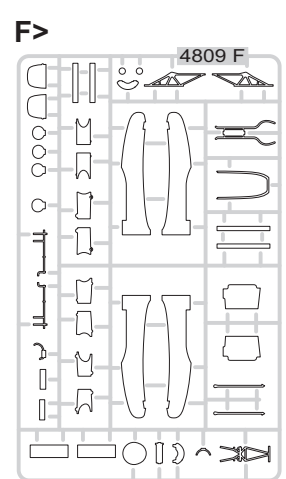
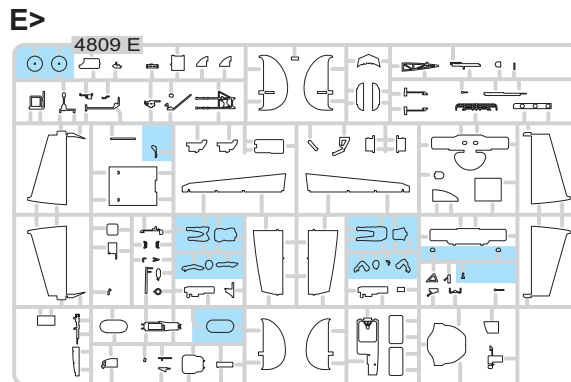
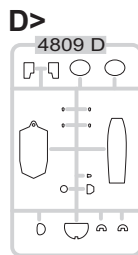
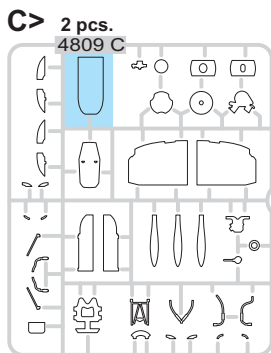
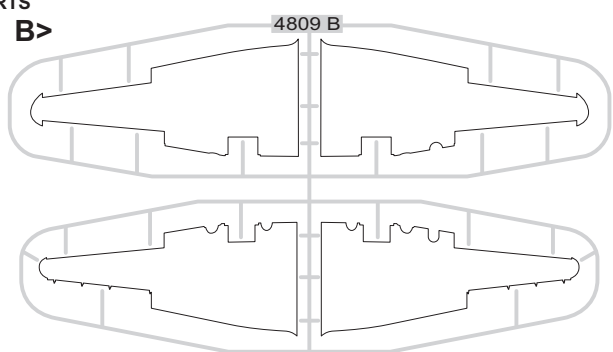
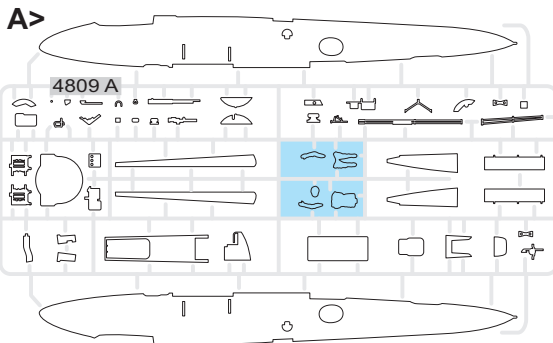

## PE - PHOTO ETCHED DETAIL PARTS

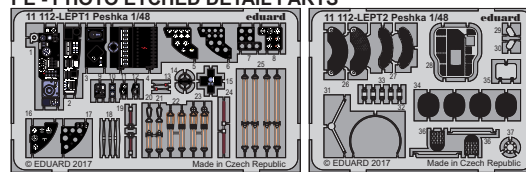

eduard  
MASK

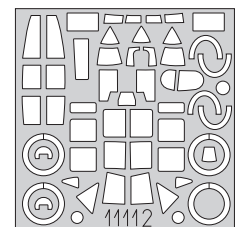

## RP - RESIN PARTS

R1 2 pcs.



R2



R3 2 pcs.



R4 6 pcs.



R5 2 pcs.



R6

-Parts not for use. -Teile werden nicht verwendet. -Pièces à ne pas utiliser. -Tyto díly nepoužívejte při stavbě. - 使用しない部品



GSI Creos (GUNZE)		
AQUEOUS	Mr.COLOR	
H2	C2	BLACK
H4	C4	YELLOW
H6	C6	GREEN
H11	C62	WHITE
H12	C33	FLAT BLACK
H13	C3	FLAT RED
H27	C44	TAN
H47	C41	RED BROWN
H67	C115	LIGHT BLUE
H72	C22	DARK EARTH
H76	C61	BURNT IRON
H77	C137	TIRE BLACK

AQUEOUS	Mr.COLOR	
H78	C38	OLIVE DRAB
H90	C47	CLEAR RED
H94	C138	CLEAR GREEN
H303	C303	GREEN
H305	C305	GRAY
H325	C325	GRAY
H331	C331	DARK SEAGRAY
Mr.METAL COLOR		
MC214		DARK IRON
MC218		ALUMINIUM
Mr.COLOR SUPER METALLIC		
SM01		SUPER CHROME

# FOR OPEN LEFT ENGINE ONLY

1

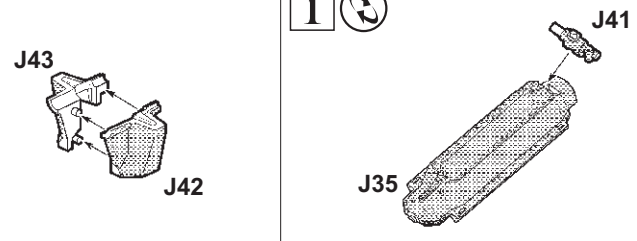

2

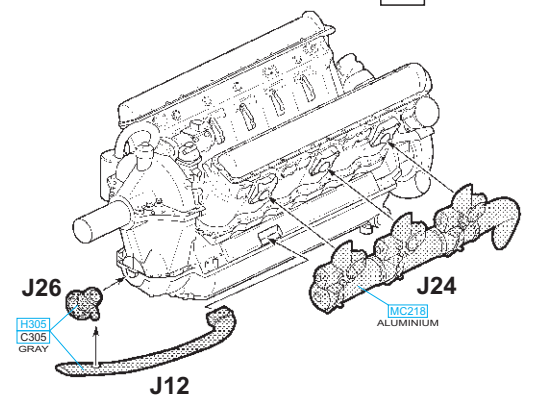
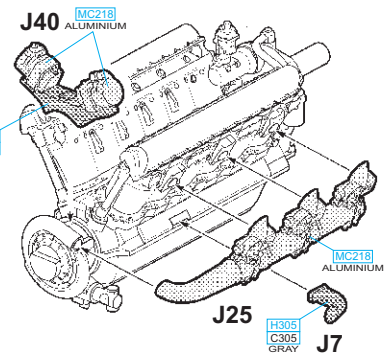
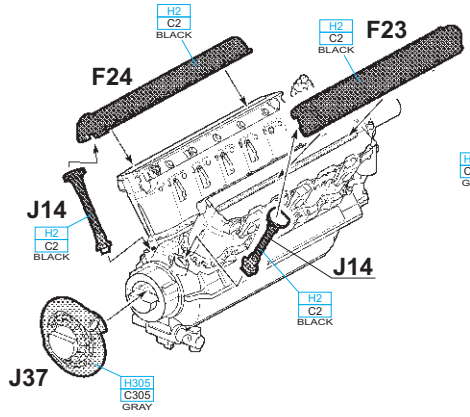
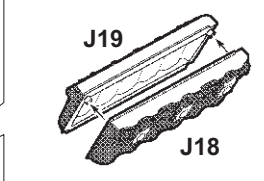
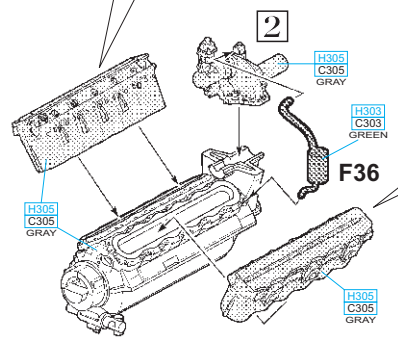
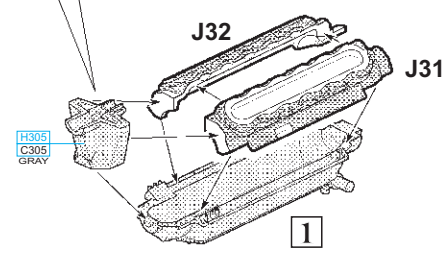

4

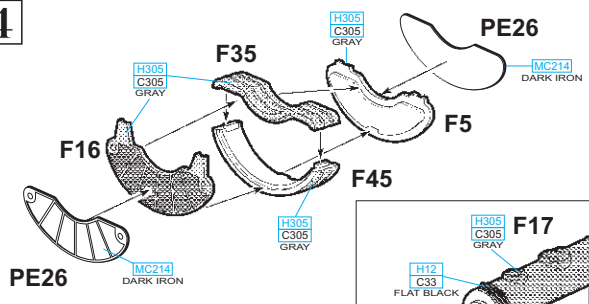

3

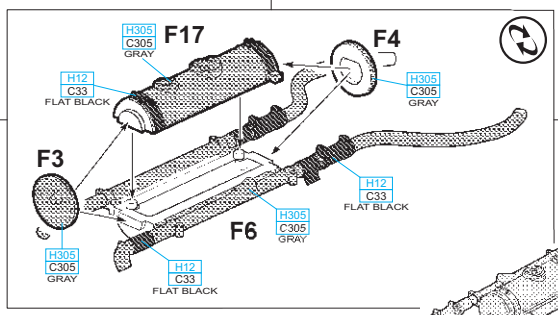
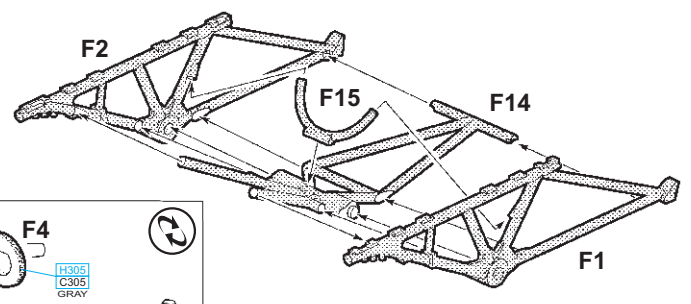

5

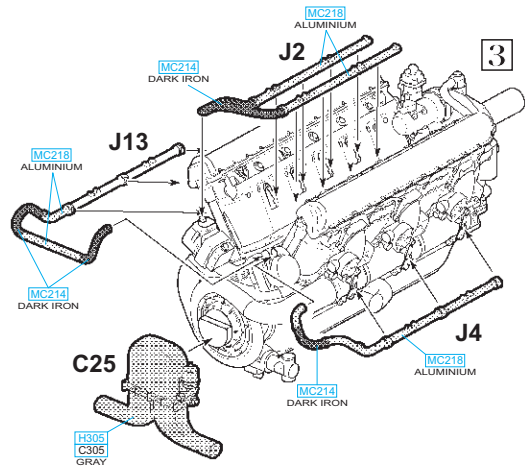

3

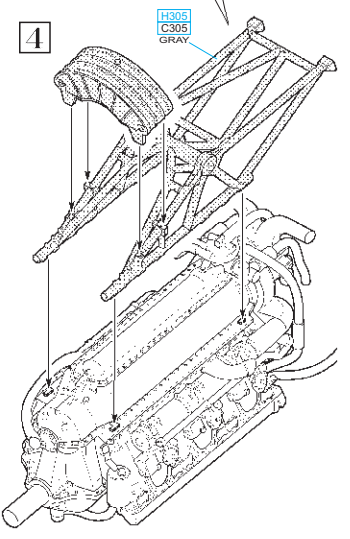
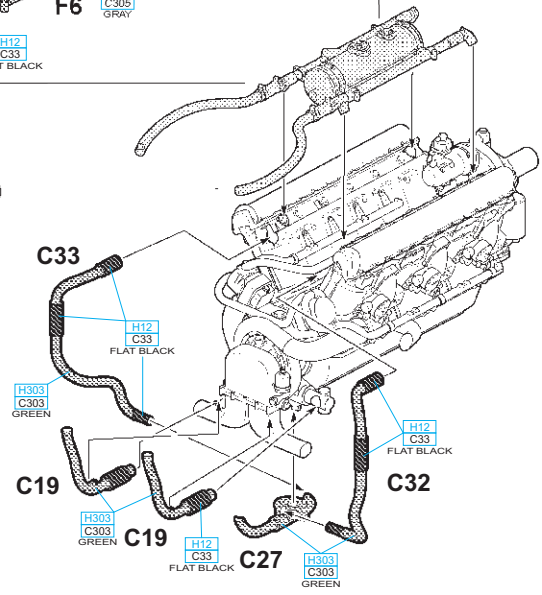

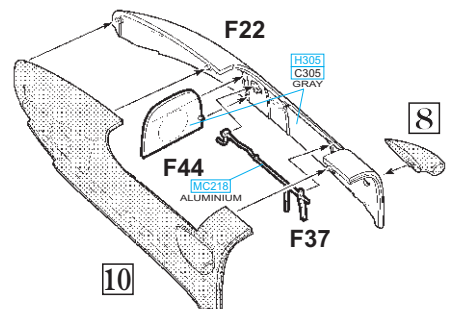
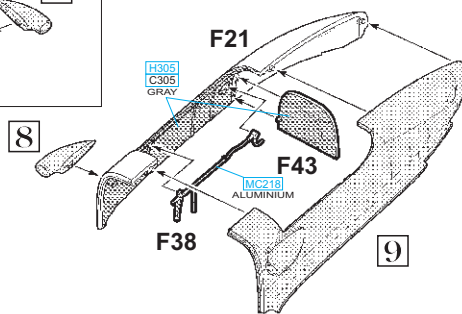
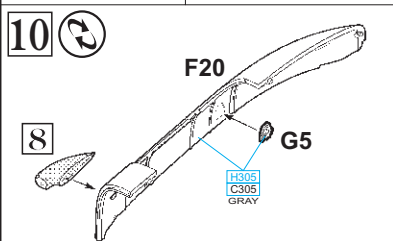
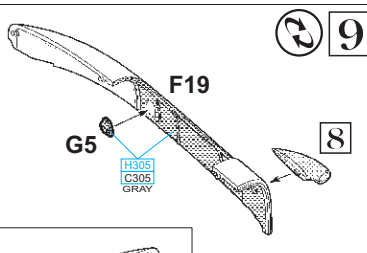
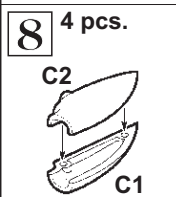
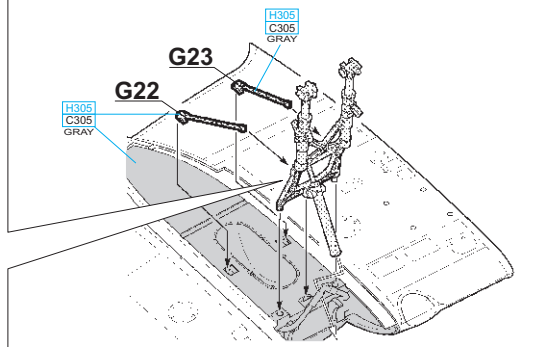
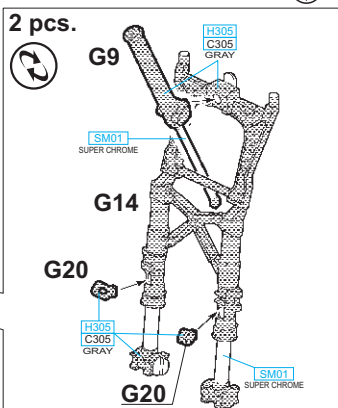
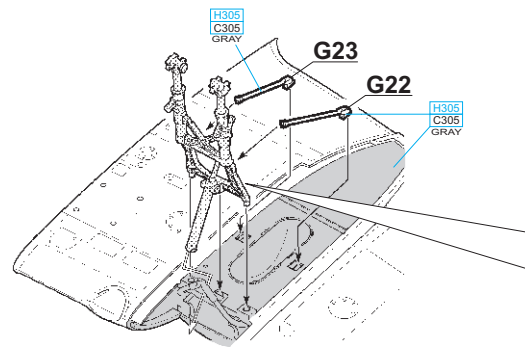
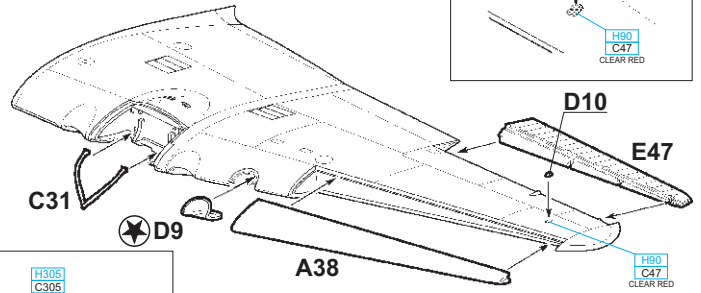
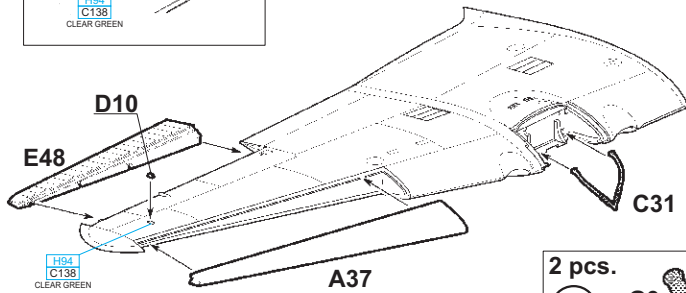
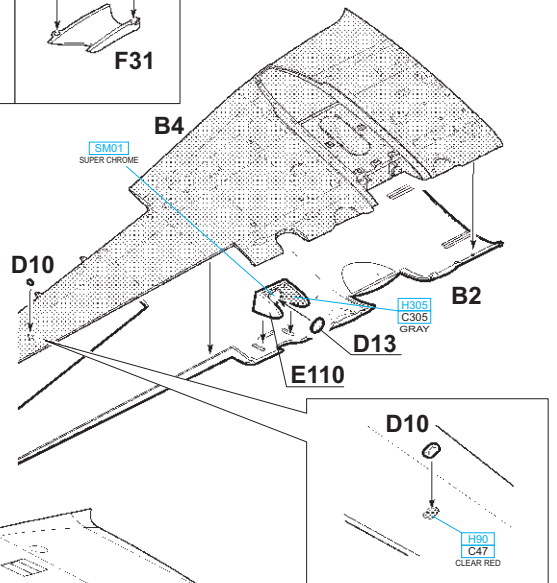
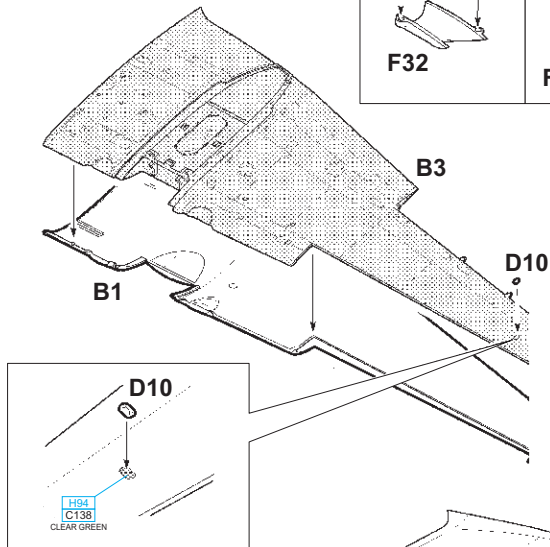
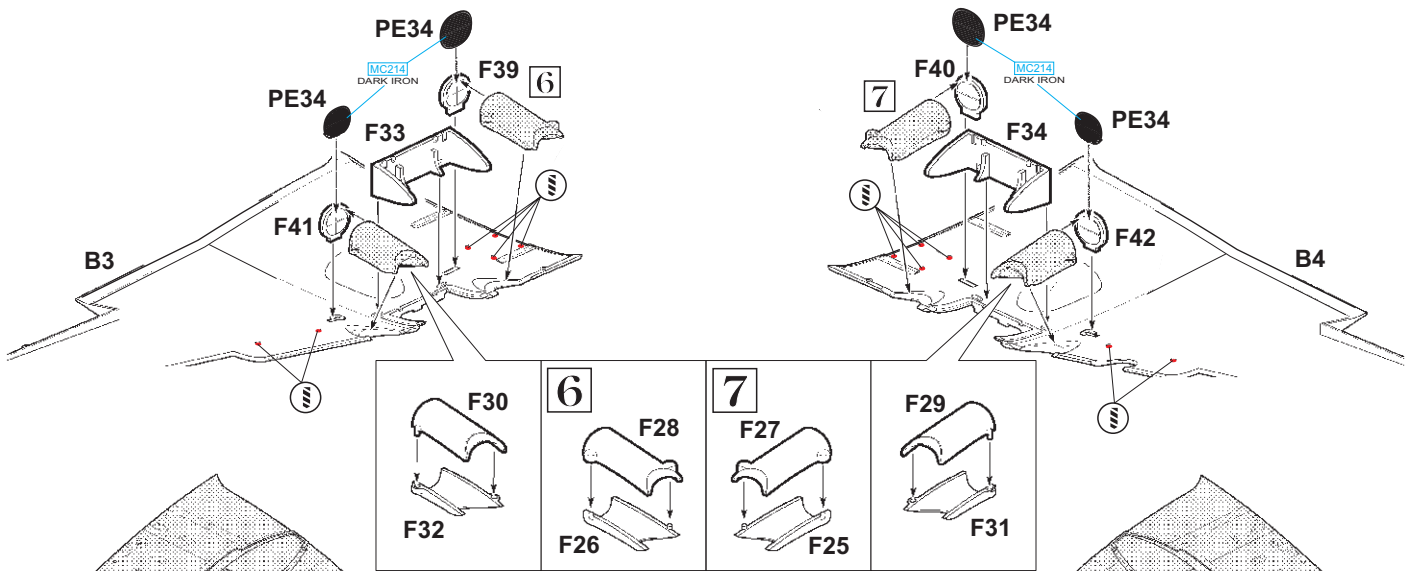

11 2 pcs.

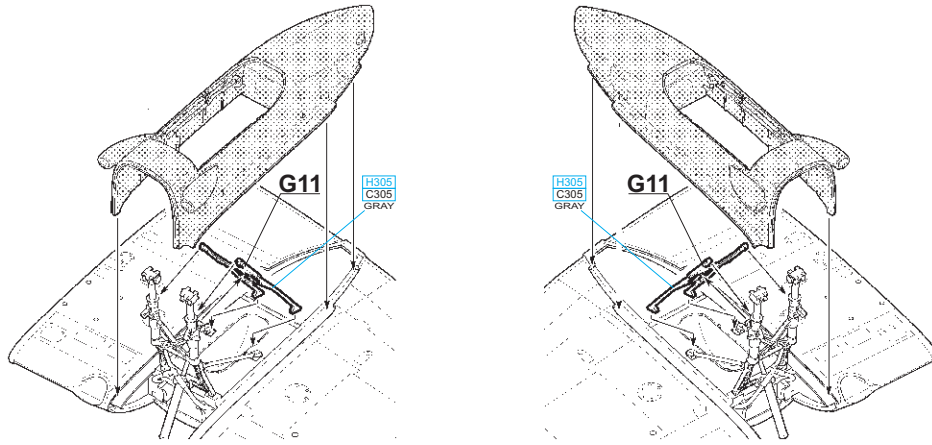
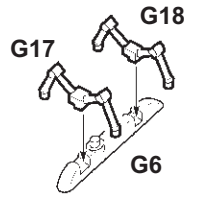

12 2 pcs.

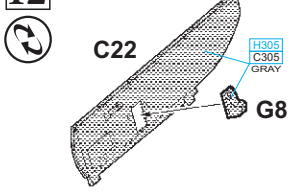

13 2 pcs.

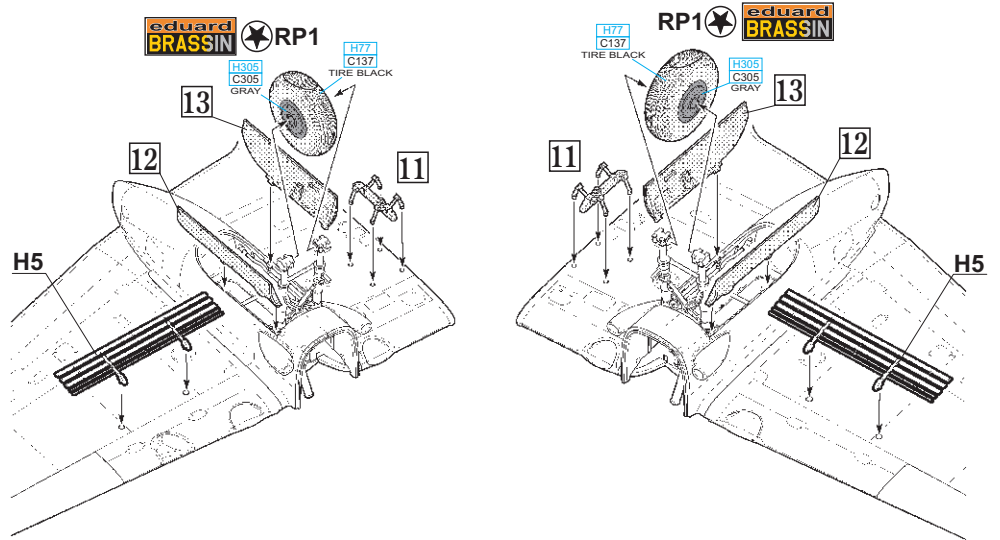
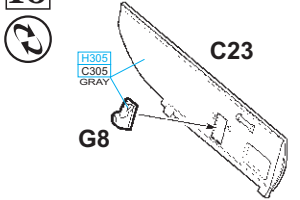

14

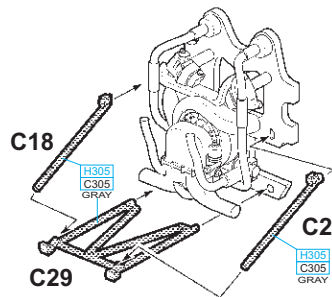
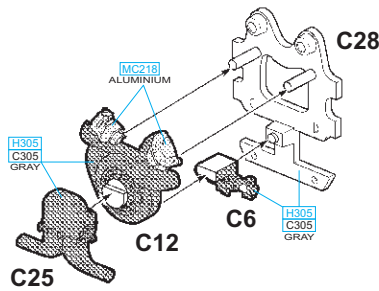

15 2 pcs.

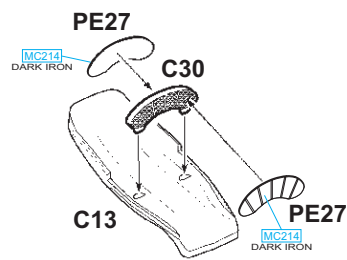

16 2 pcs.

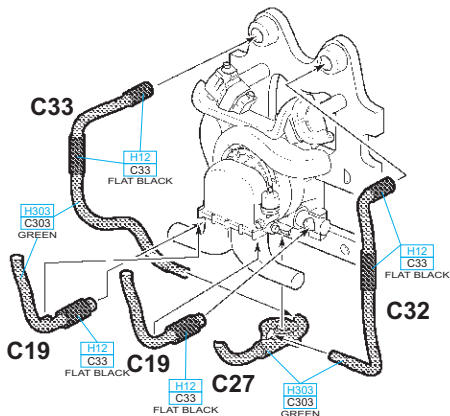
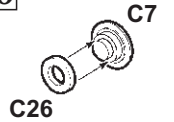

2 pcs.

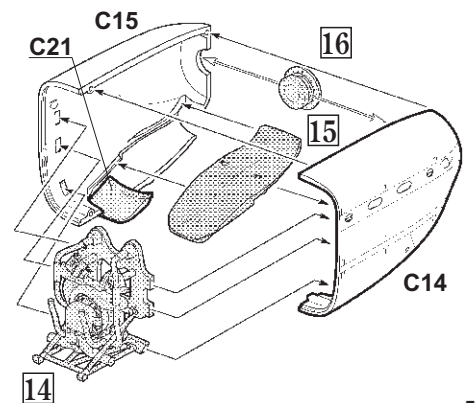
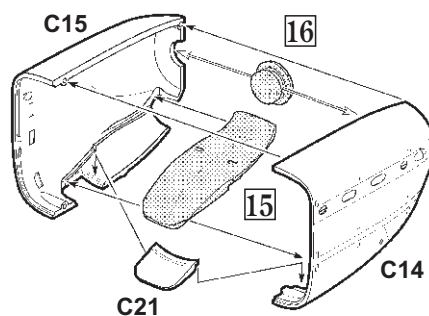

17

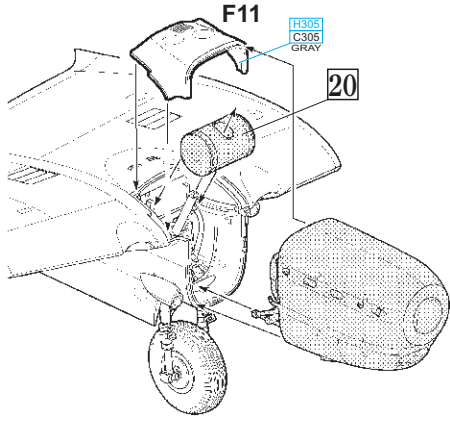

18

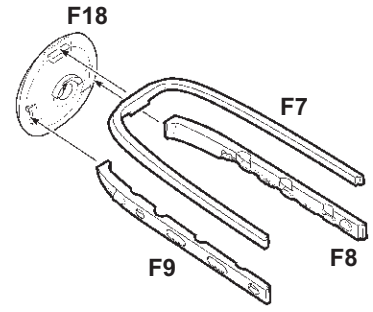

19

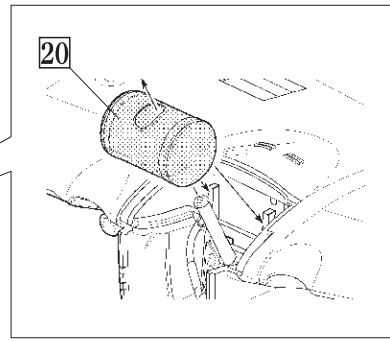
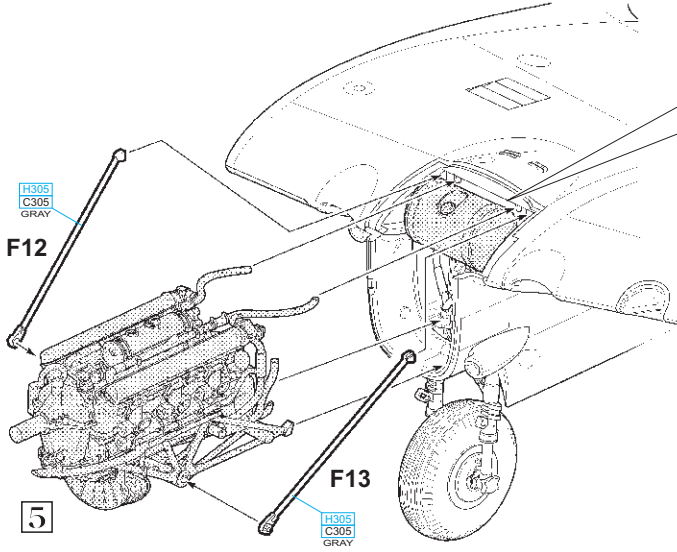

20 2 pcs.

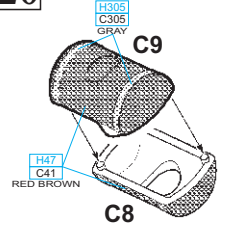

2 pcs.

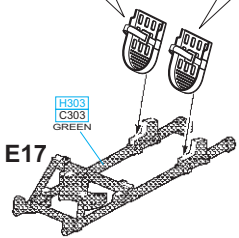
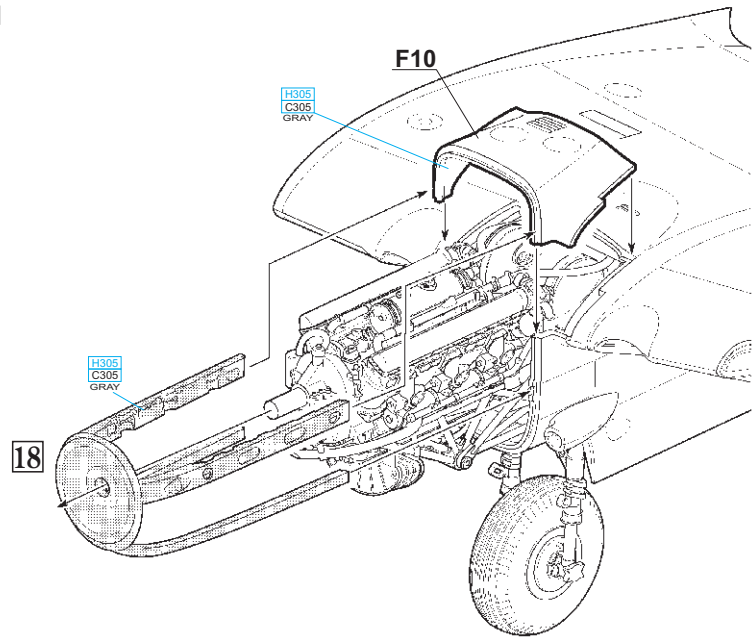
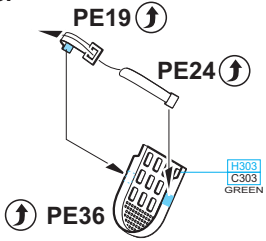

22

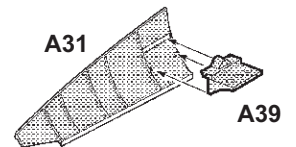

21

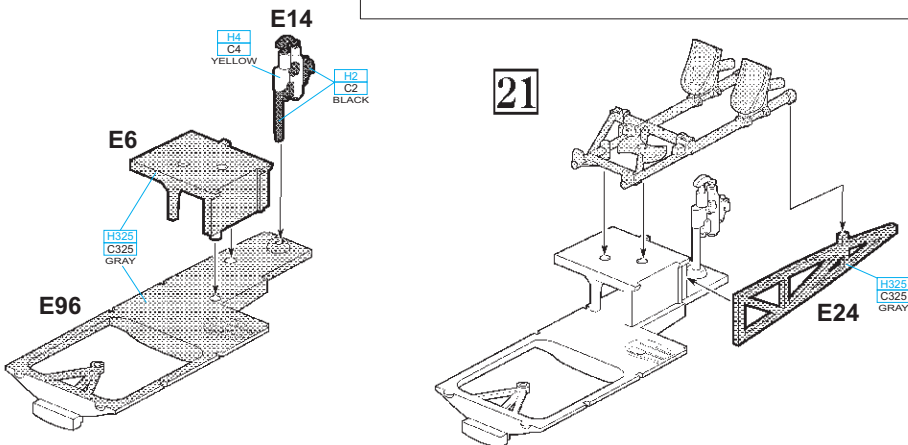



24

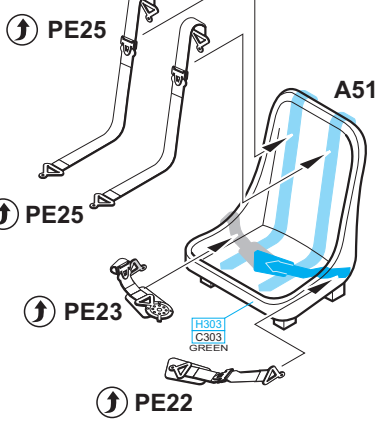
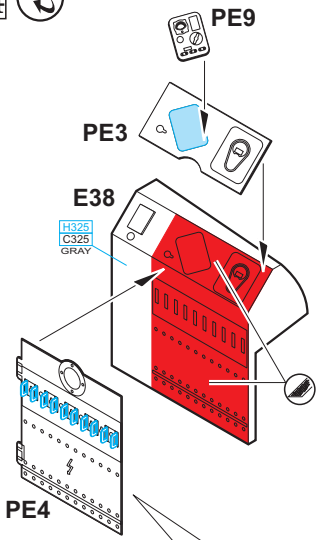

25

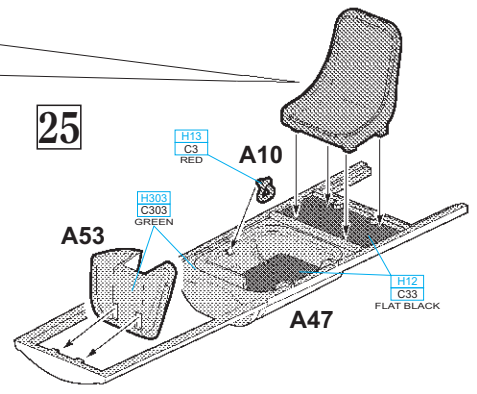

24

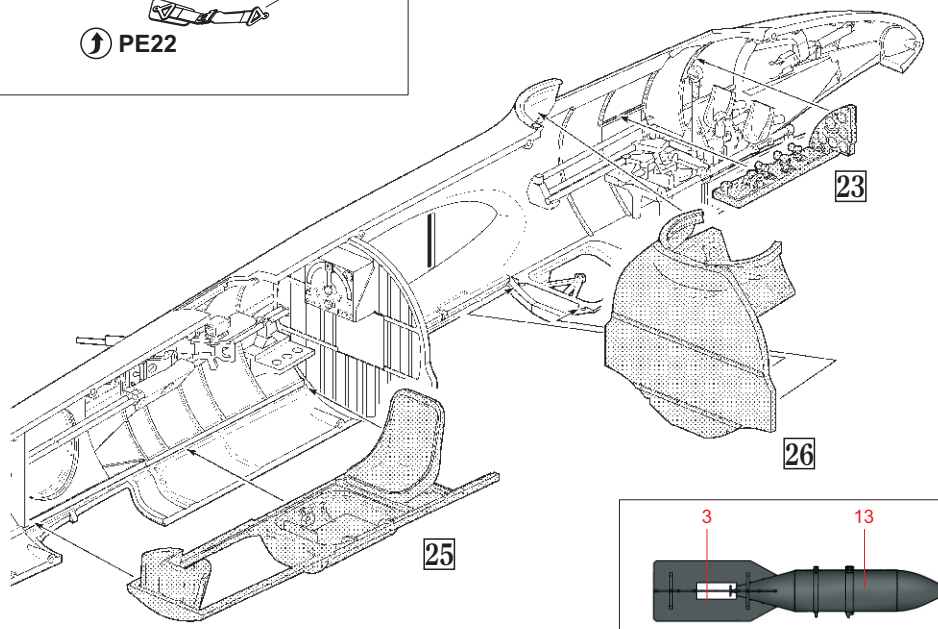
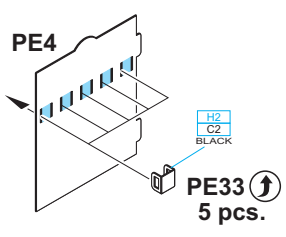

26

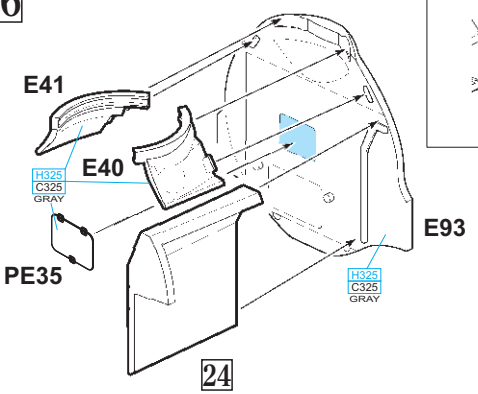

27 2 pcs.

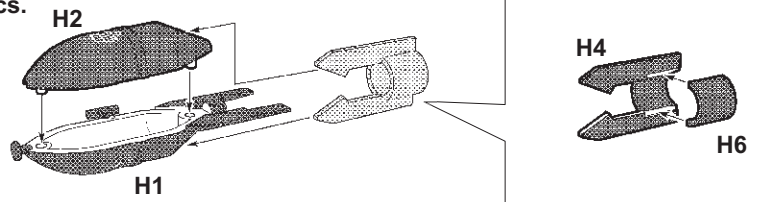

28

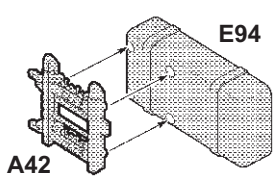

29

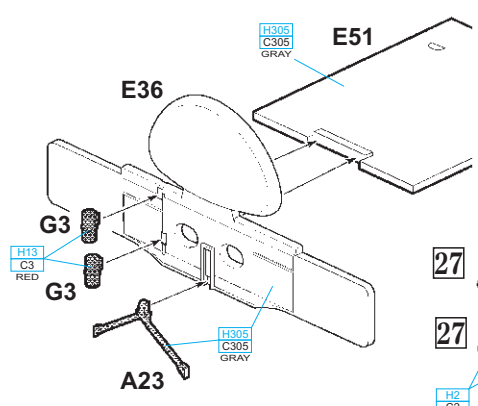
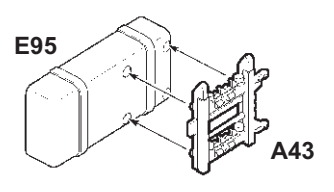

27

27

H2 C2 BLACK

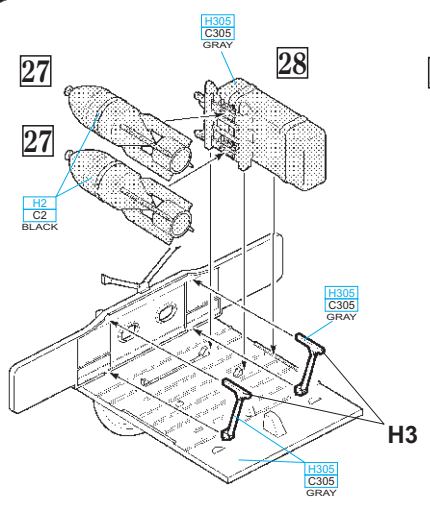

30

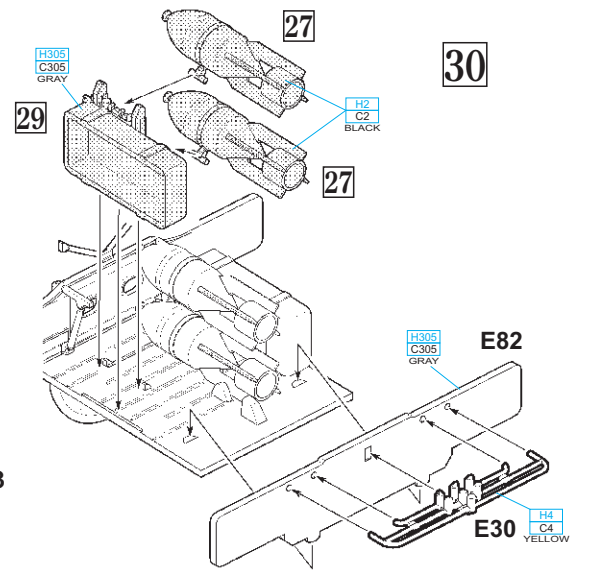



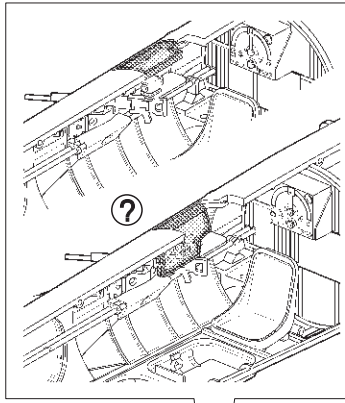
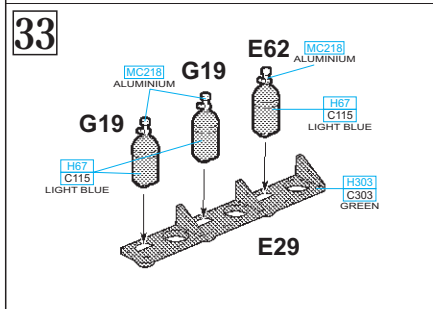
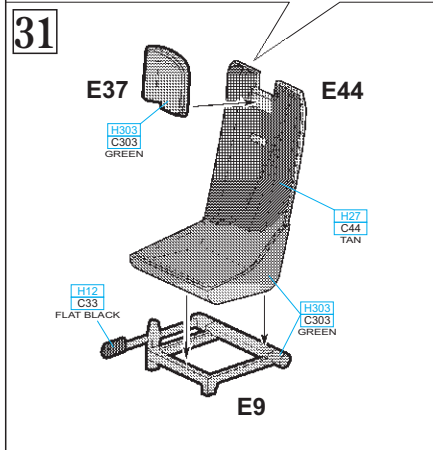
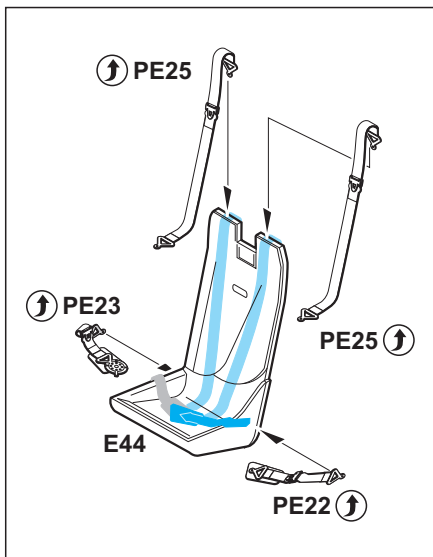

D4 - MARKINGS B;C;D ONLY

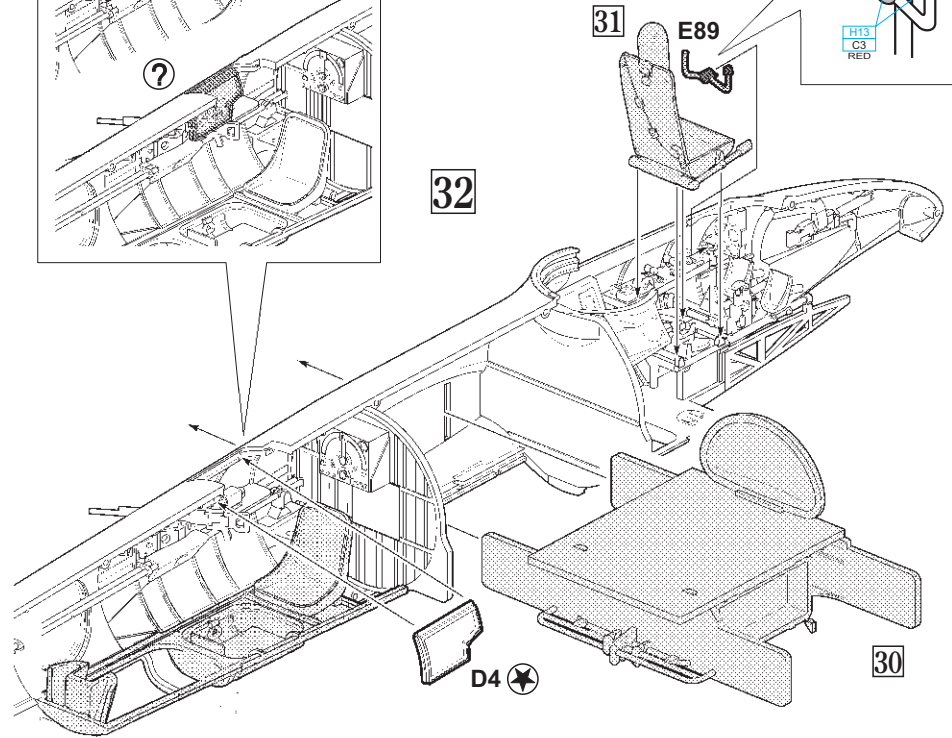
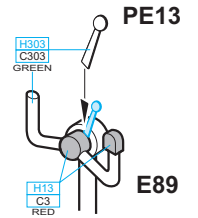

MARKINGS A;E ONLY

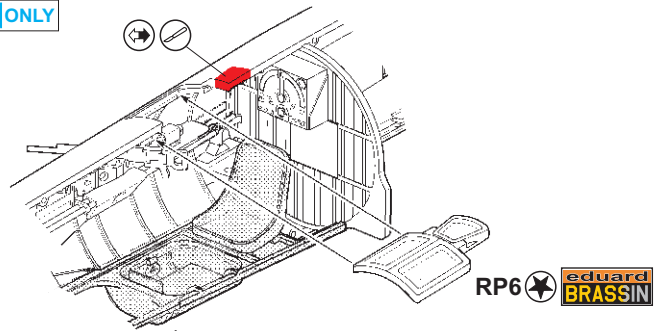

RP6 eduard BRASSIN

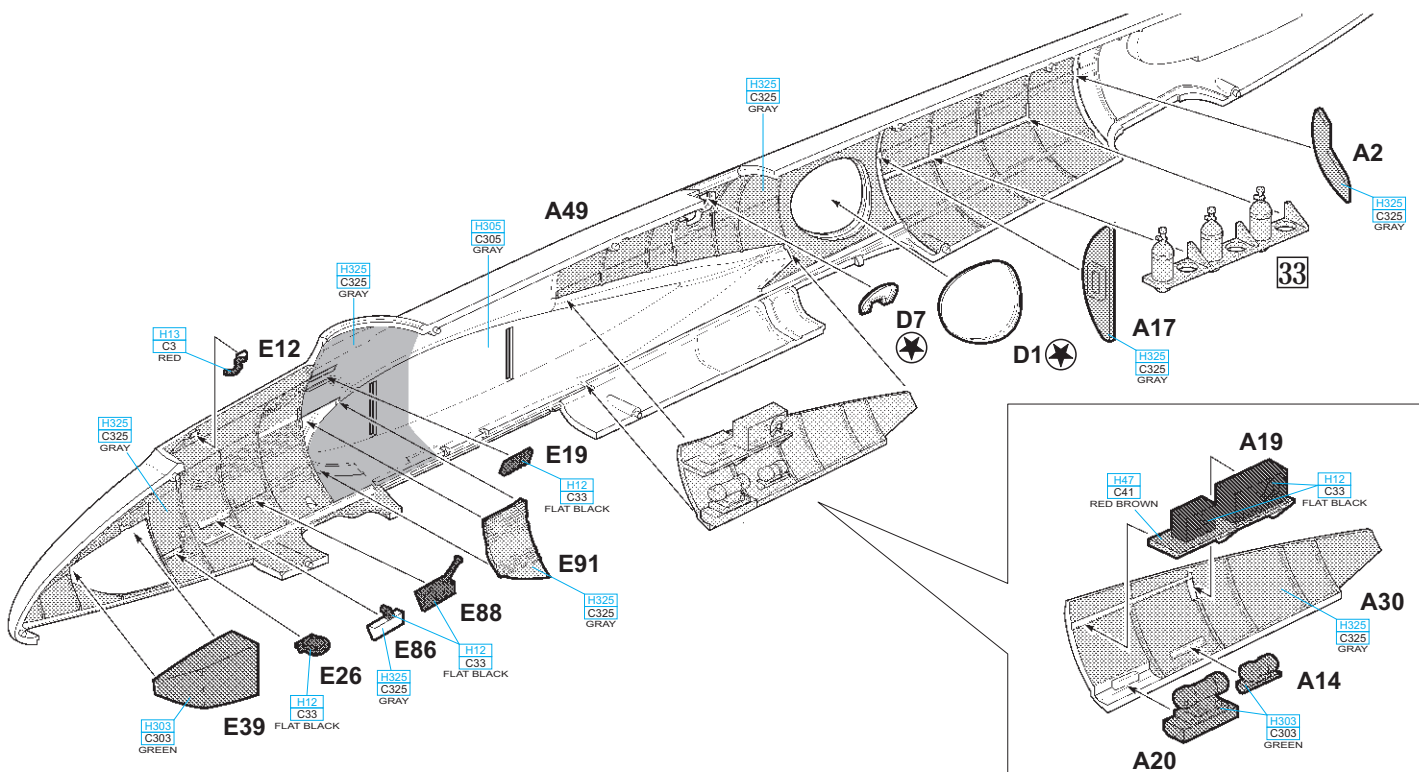

34

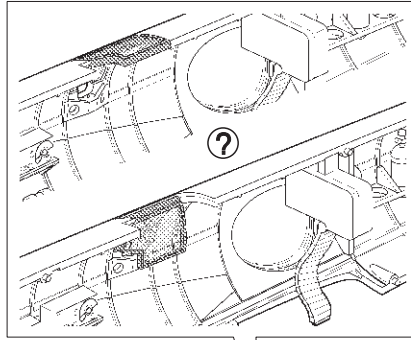
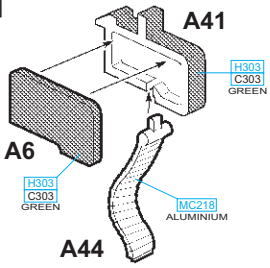

D3 - MARKINGS B,C,D

35

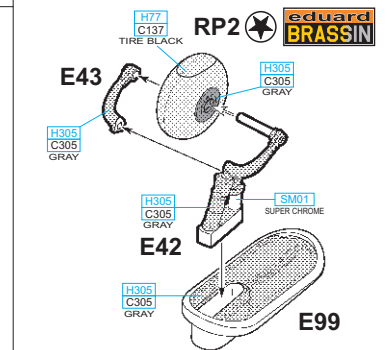
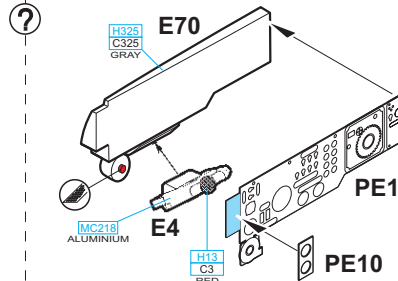
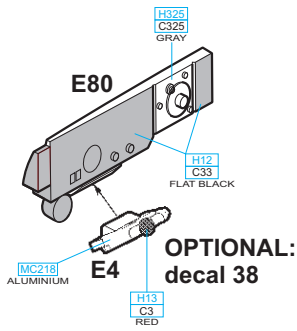
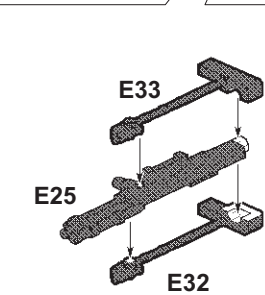
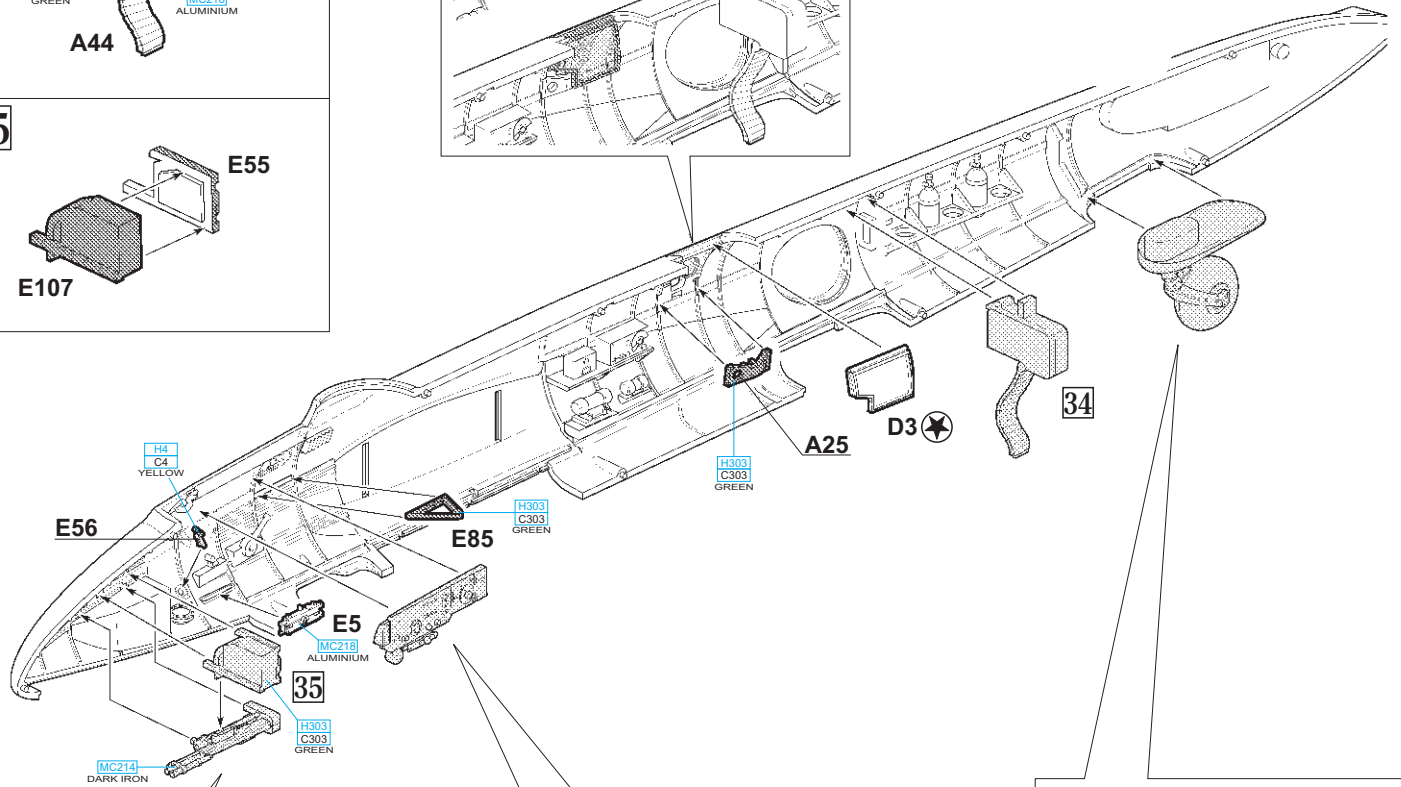
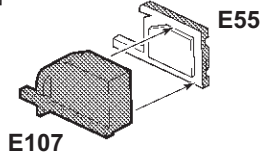

36

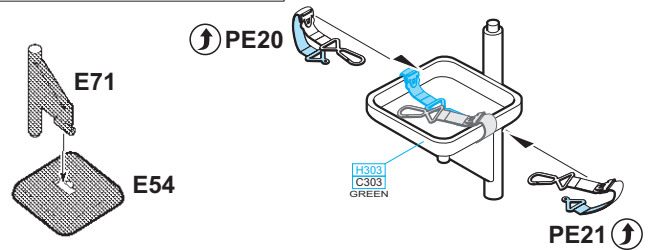
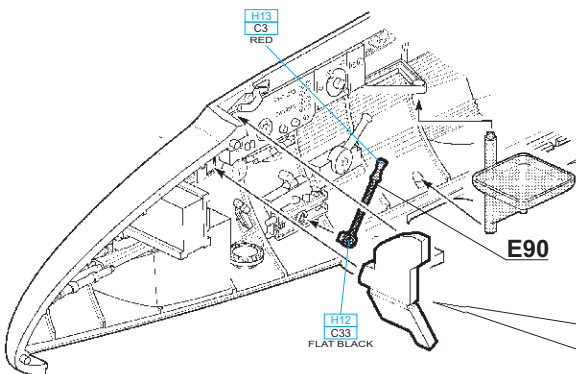

OPTIONAL:  
decal 36

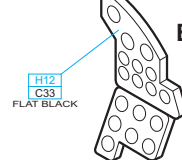

OPTIONAL:  
decal 34

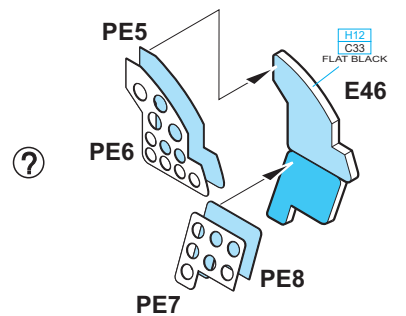

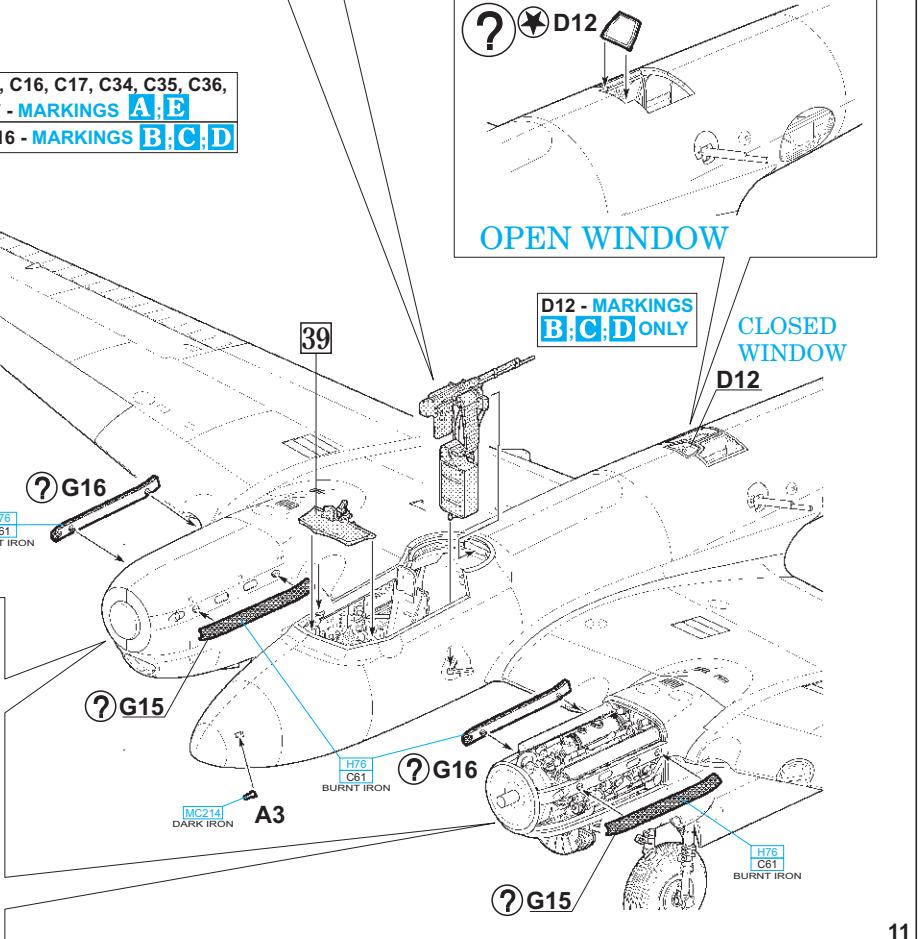
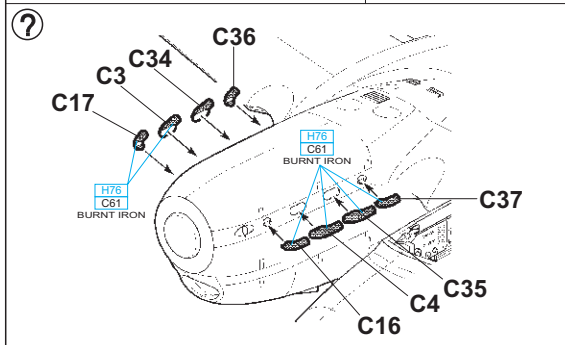
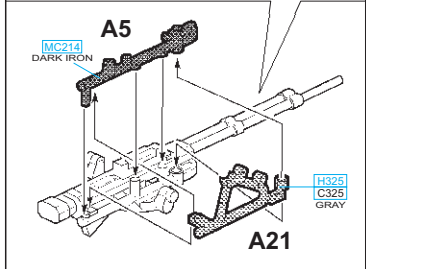
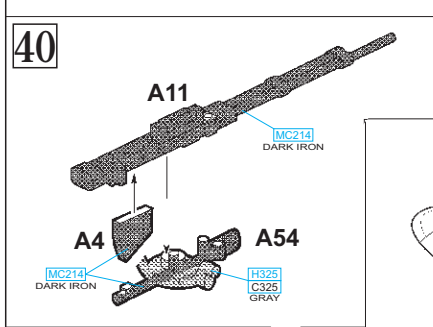
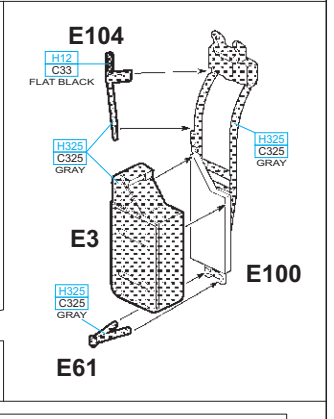
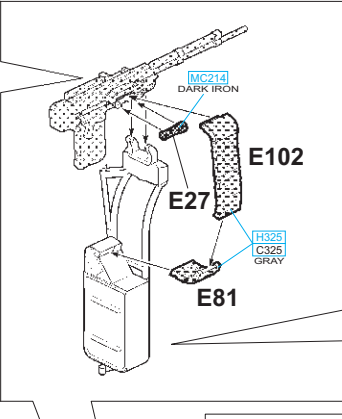
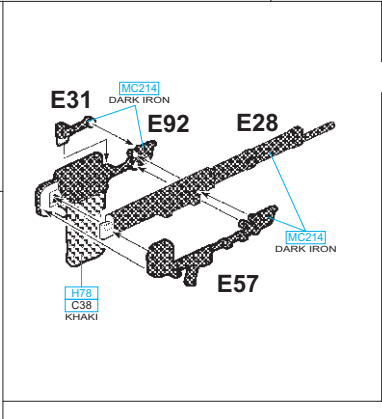
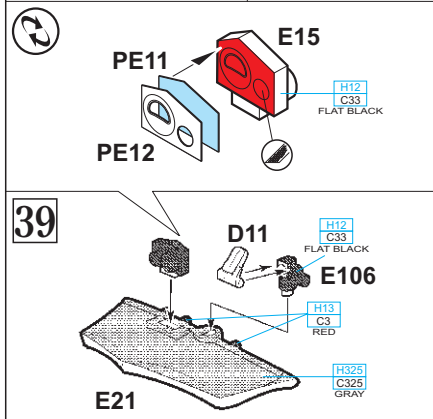
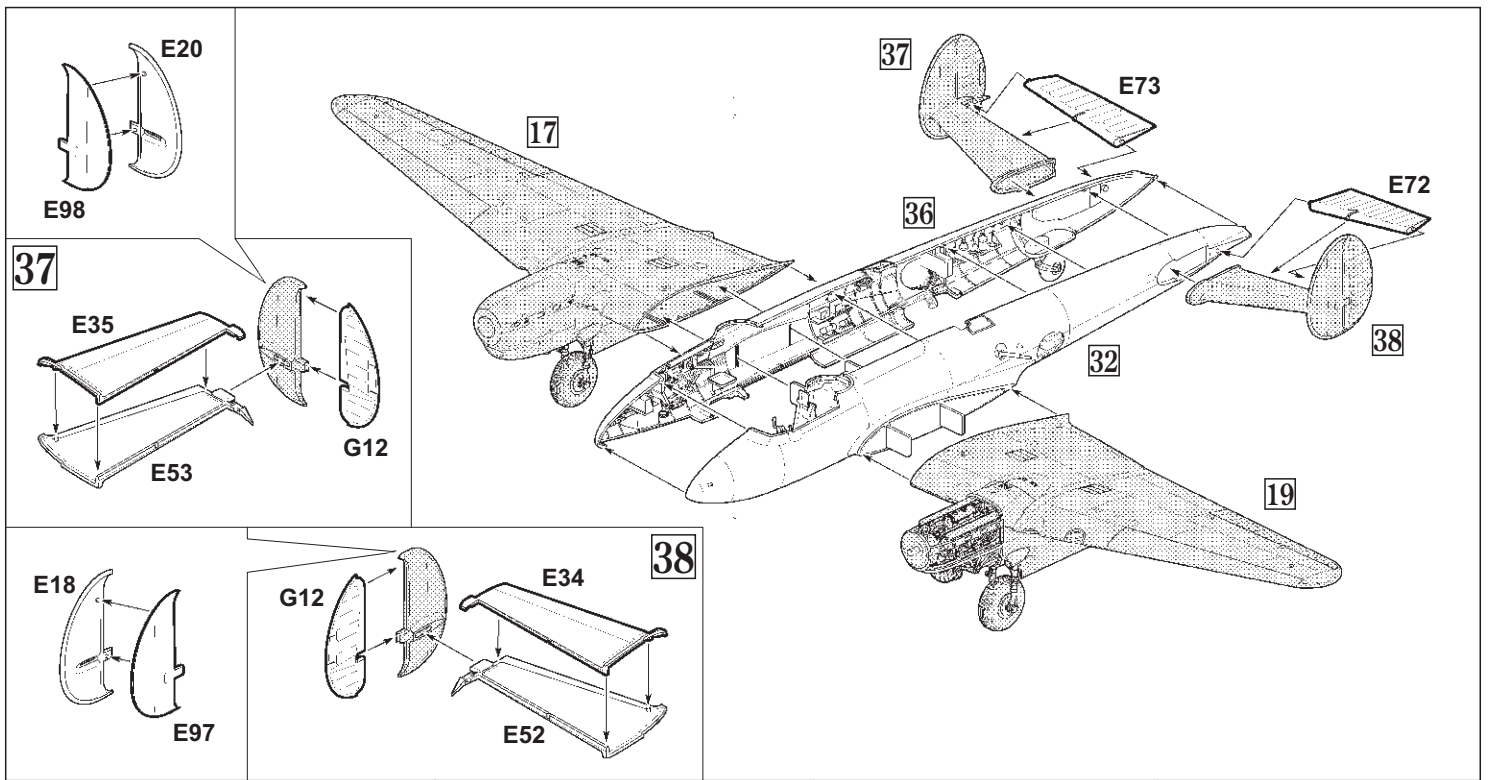

C3, C4, C16, C17, C34, C35, C36,  
 C37 - MARKINGS **A, E**  
 G15, G16 - MARKINGS **B, C, D**

**OPEN WINDOW**

**D12 - MARKINGS B, C, D ONLY**

**CLOSED WINDOW**

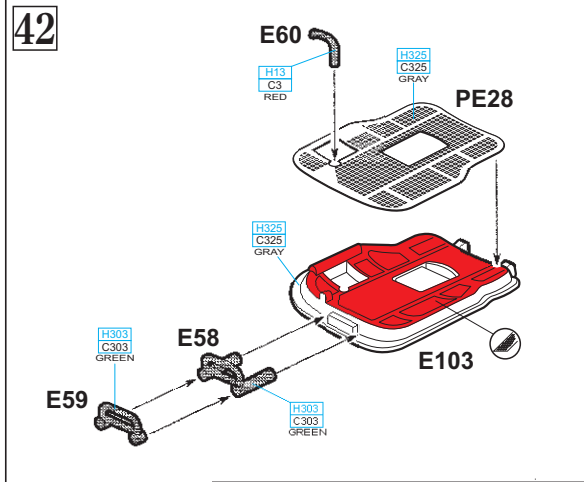
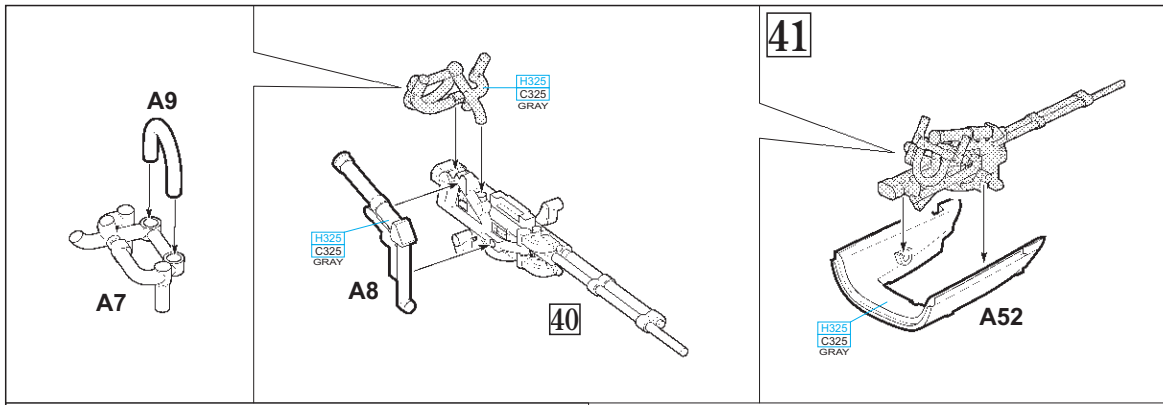

OPEN BOMB BAY  
OPEN ENTRANCE DOOR

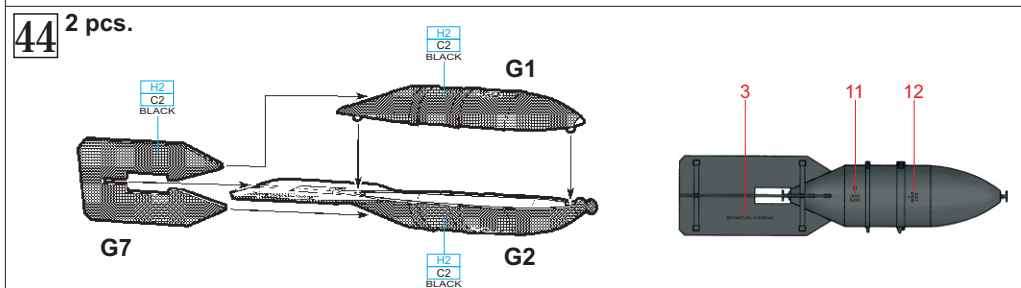
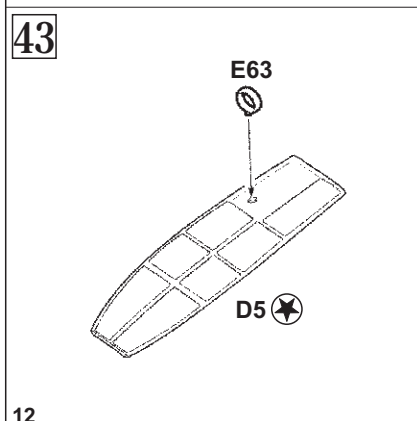
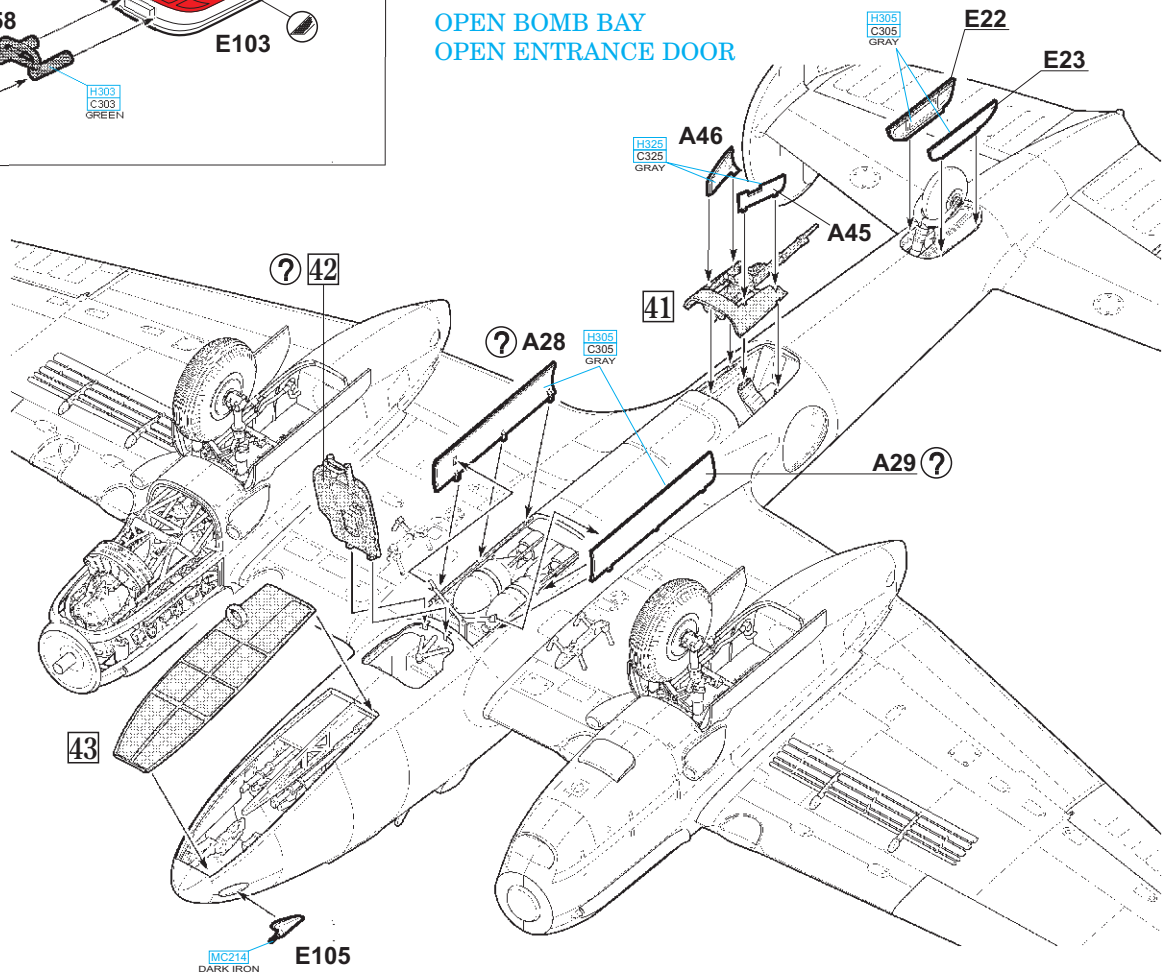

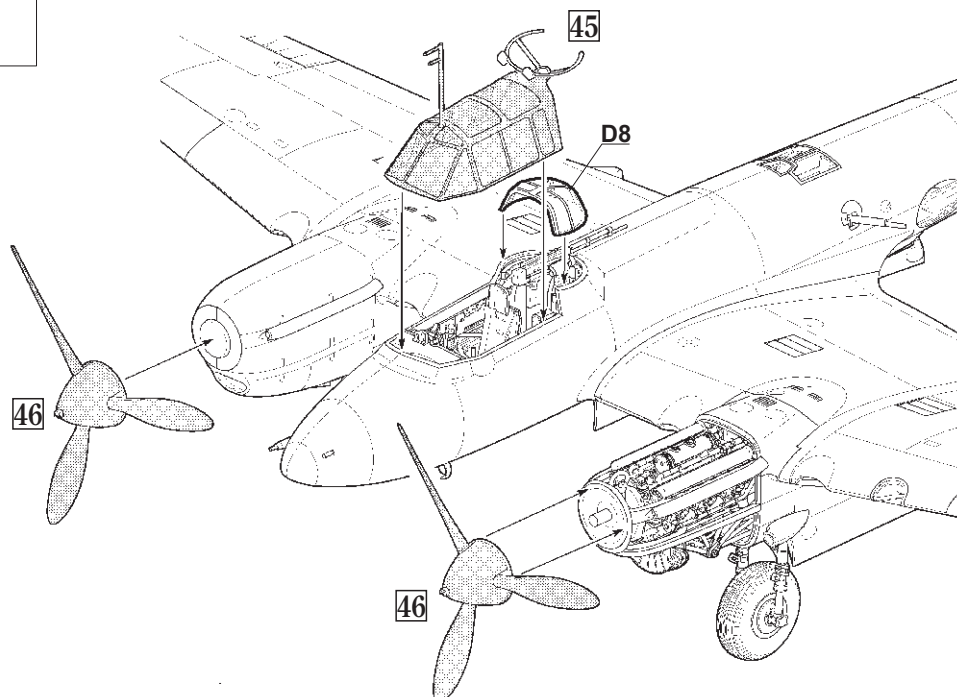
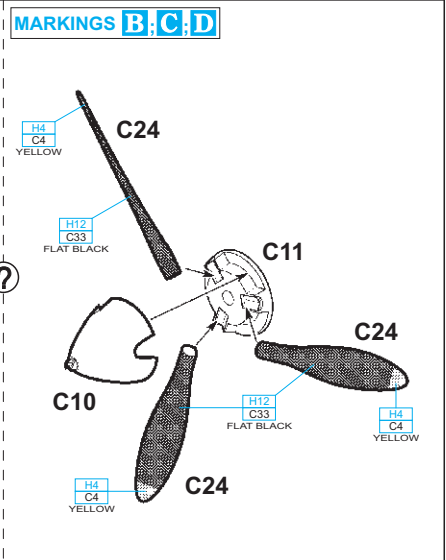
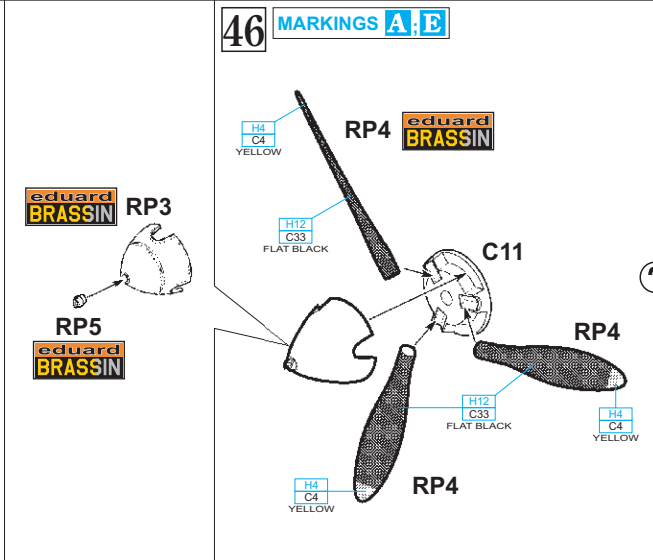
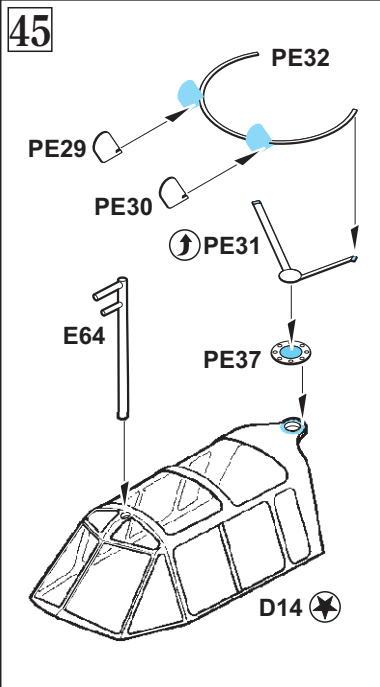
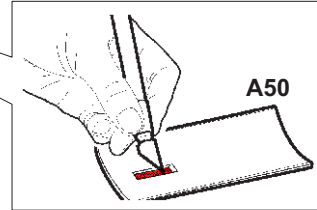
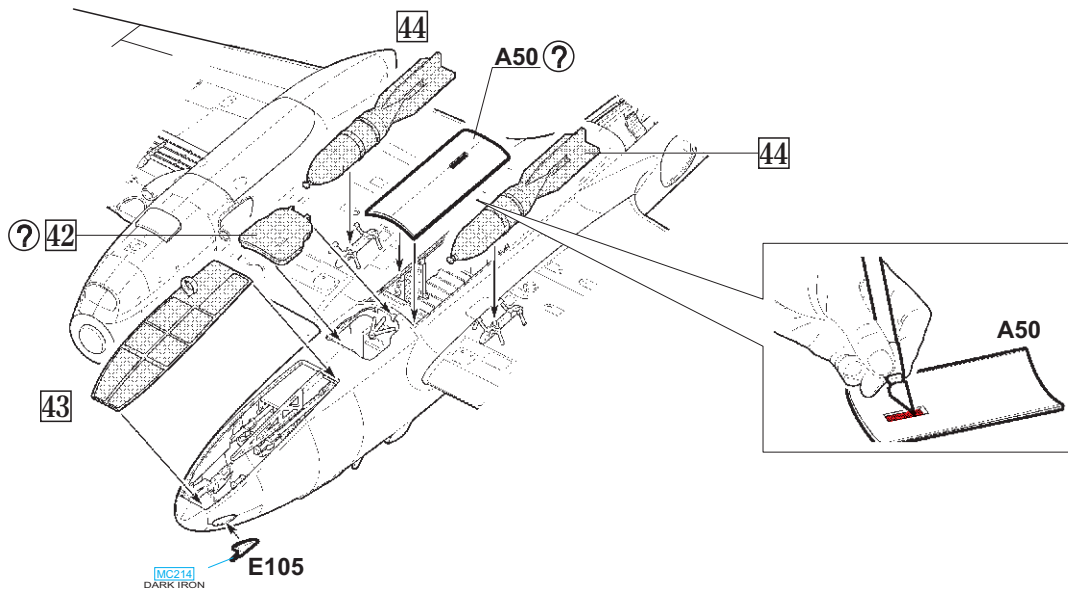

11112

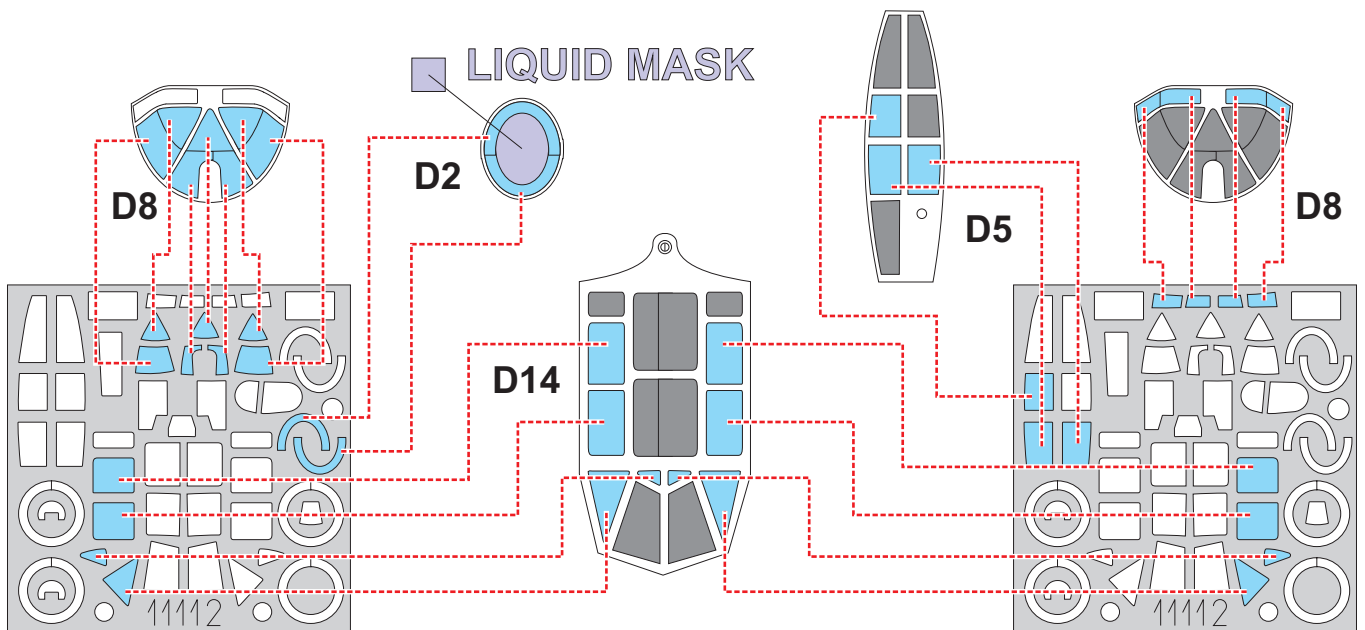
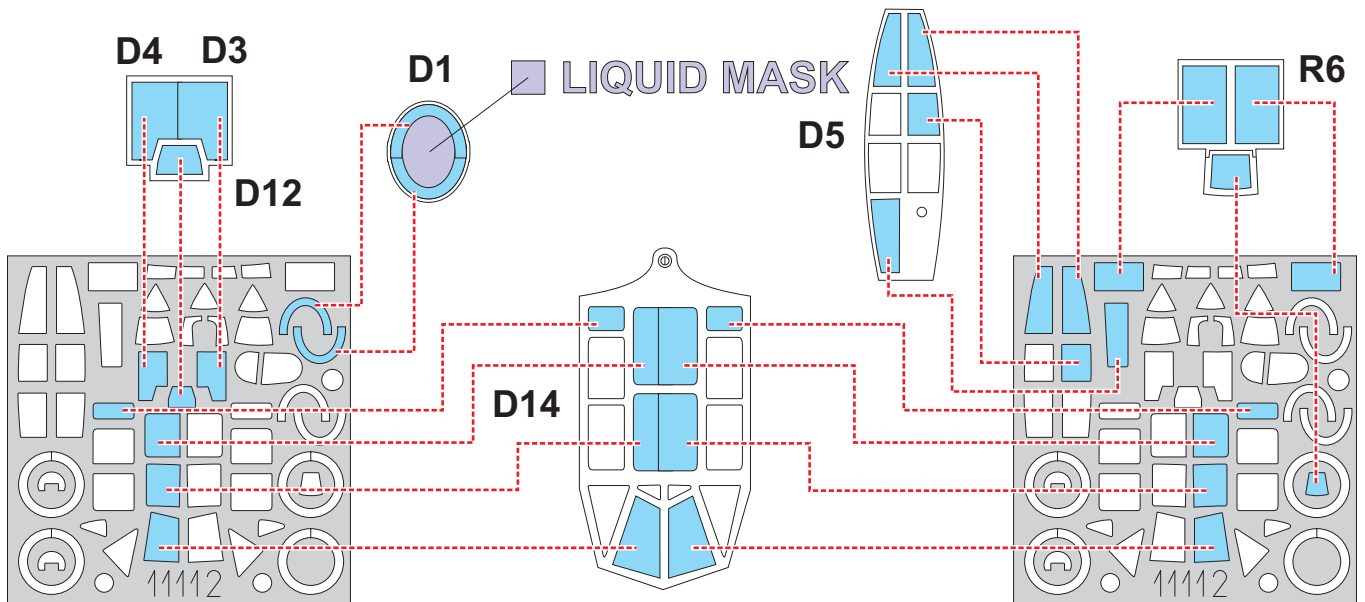
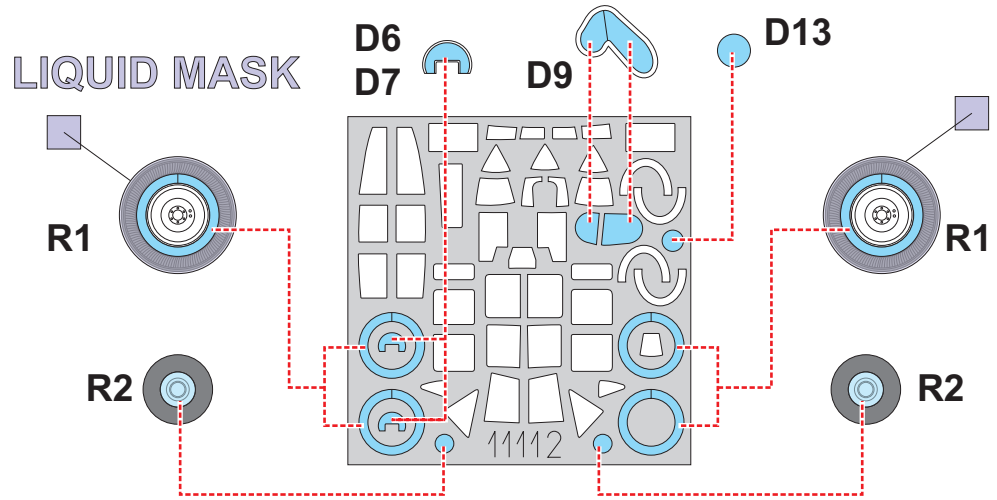
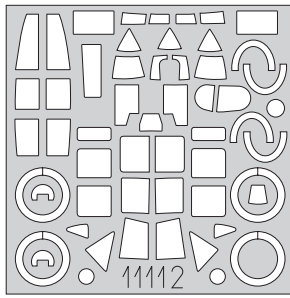

# A Pe-2 later (post 359th) production batch, flown by Senior Lieutenant E. Sedov, 40th Bomber Air Regiment, Soviet Navy Black Sea Fleet Aviation, August 1944

Senior Lieutenant Eugeniy Sedov was the stepbrother of the famous VVS RKKA pilot, Boris Safonov (who was killed in combat in May 1942). In honour of Safonov, there was a slogan painted on the port side of the aircraft. The starboard side received the Order of the Red Banner. This aircraft was also painted according to the directives issued in 1943, position of camouflage colors is standard Type No.2. The flat white spinners and the stripes on the upper surfaces of the wings were quick recognition features for the regiment.

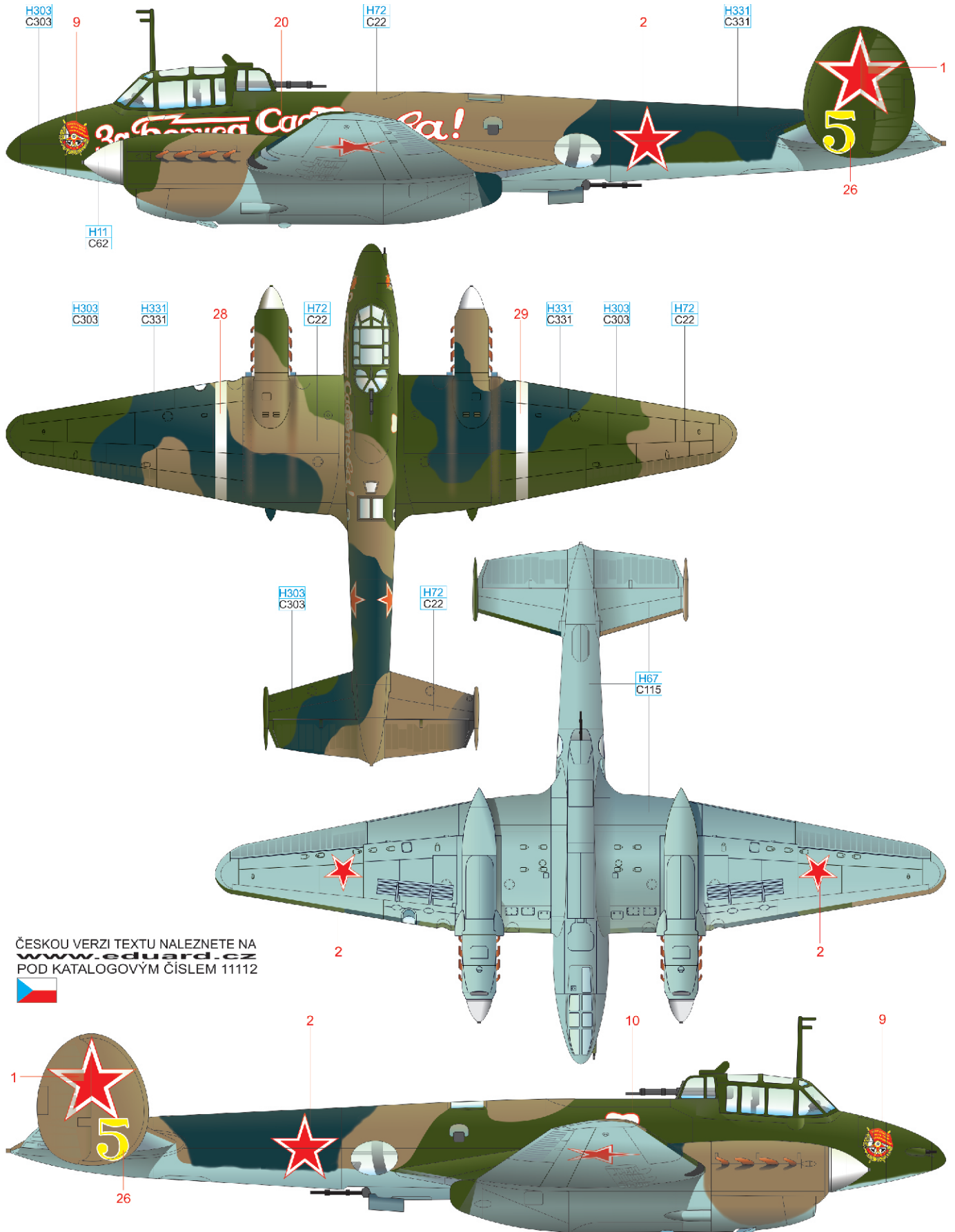

ČESKOU VERZI TEXTU NALEZNETE NA  
[www.eduard.cz](http://www.eduard.cz)  
 POD KATALOGOVÝM ČÍSLEM 11112



BROWN A-21m	H72 C22	GREEN A-24m	H303 C303	BLUE A-28m	H67 C115	GRAY A-32m	H331 C331	WHITE	H11 C62
----------------	------------	----------------	--------------	---------------	-------------	---------------	--------------	-------	------------

# B Pe-2, later production batch, serial number 3/220, 161th Guards Bomber Regiment, 2nd Guards Bomber Air Corps, VVS RKKA, Winter 1943/44

Initial aircraft were painted according to 1943 specs, position of camouflage colors is standard type No. 1. For winter operations, the upper and side surfaces were painted with temporary white (easily removed MK-7 enamel) paint, applied randomly and missing the fuselage front section, the engine cowlings, and probably not obliterating the patriotic slogan at all. The VVS RKKA insignias on the fuselage and fins were of an unusual two tone rendition. The front part of the fuselage and the spinners carried grey stars with red outlines.

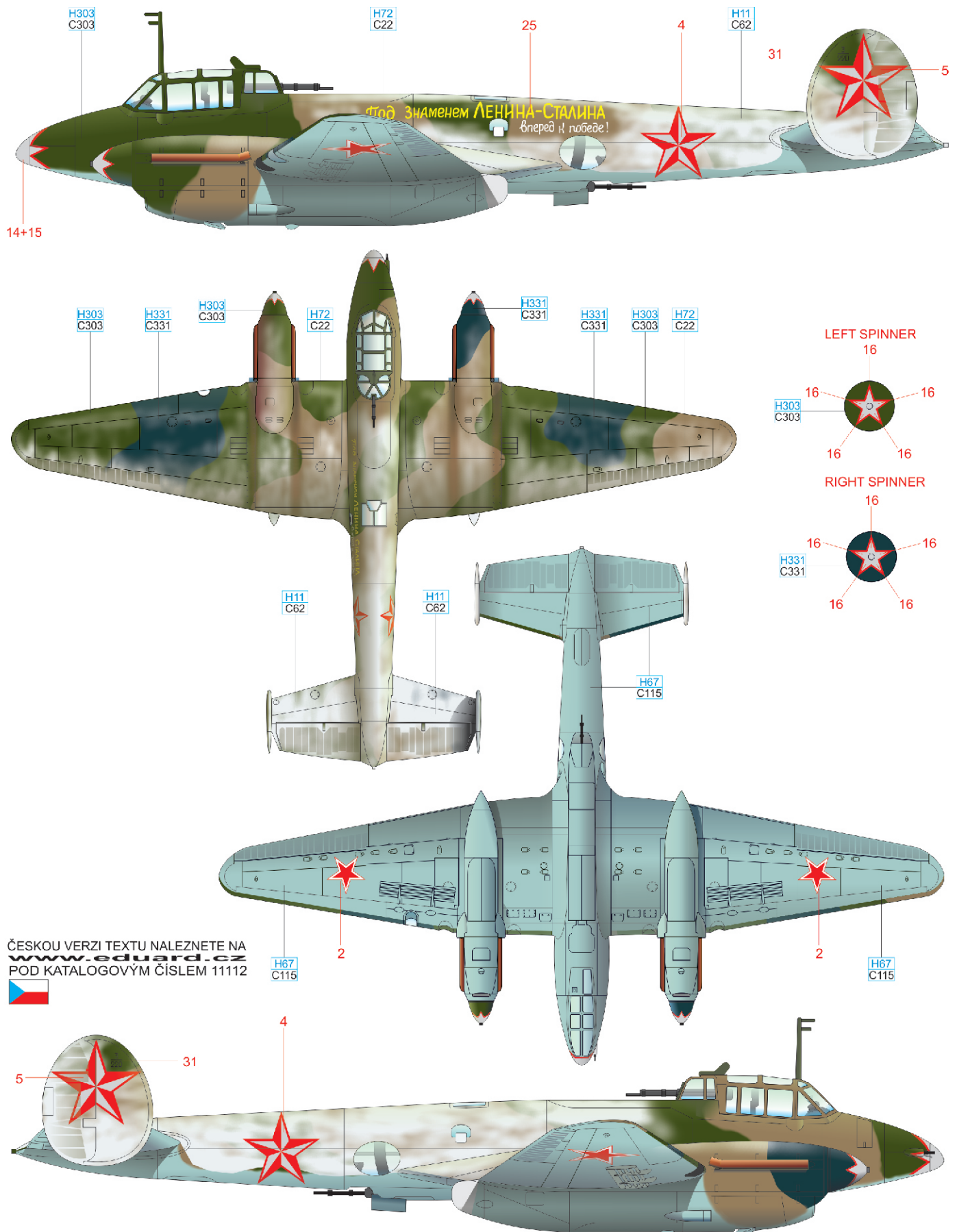

ČESKOU VERZI TEXTU NALEZNETE NA [www.eduard.cz](http://www.eduard.cz) POD KATALOGOVÝM ČÍSLEM 1112



BROWN	H72	GREEN	H303	BLUE	H67	GRAY	H331	WHITE	H11
A-21m	C22	A-24m	C303	A-28m	C115	A-32m	C331		C62



**C Pe-2 post 205th production batch, 36th Guards Bomber Regiment, 276th Bomber Division, VVS RKKA, Leningrad front, December 1944**

This aircraft was painted in accordance with the 1943 camouflage specs, position of camouflage colors is standard No.1. The port side of the front fuselage was presumably adorned with the regimental badge, a polar bear with a bomb. The yellow stripes appeared on the outside surfaces of the fins only.

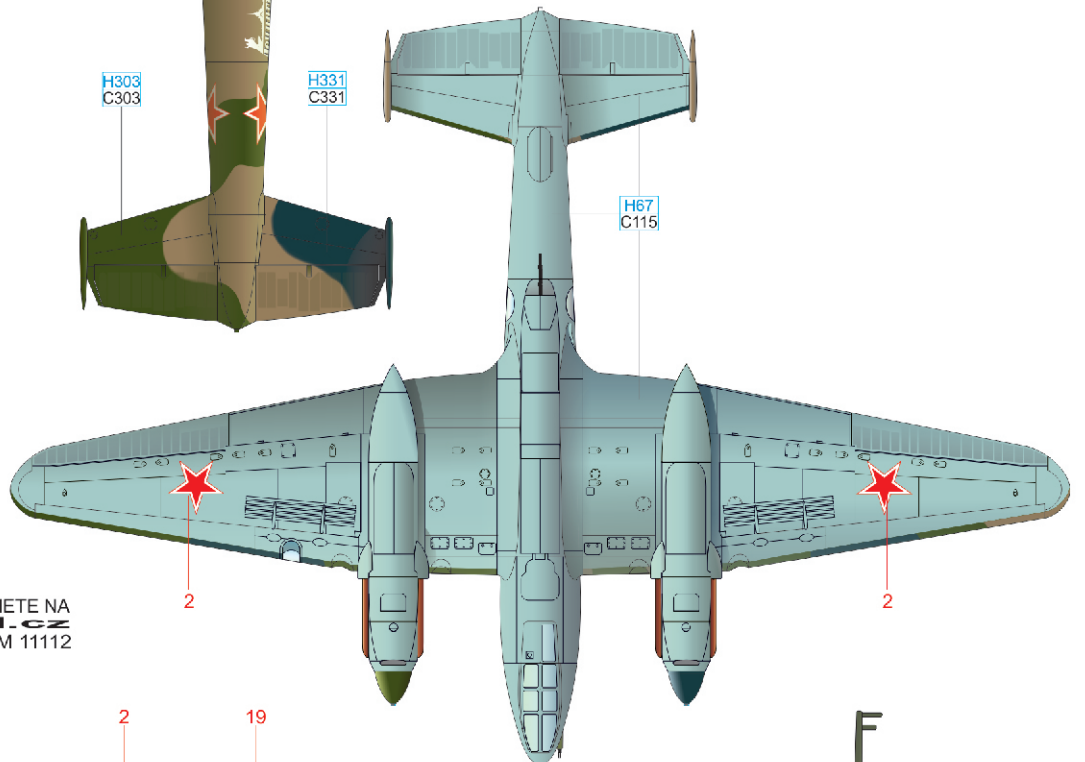
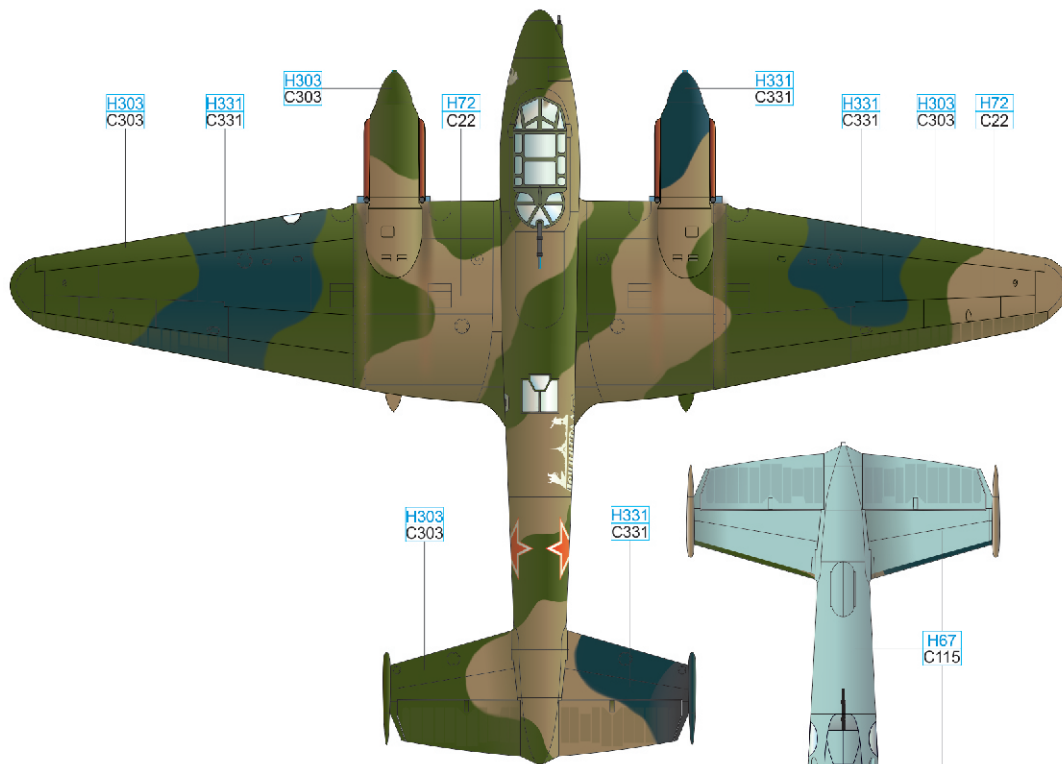
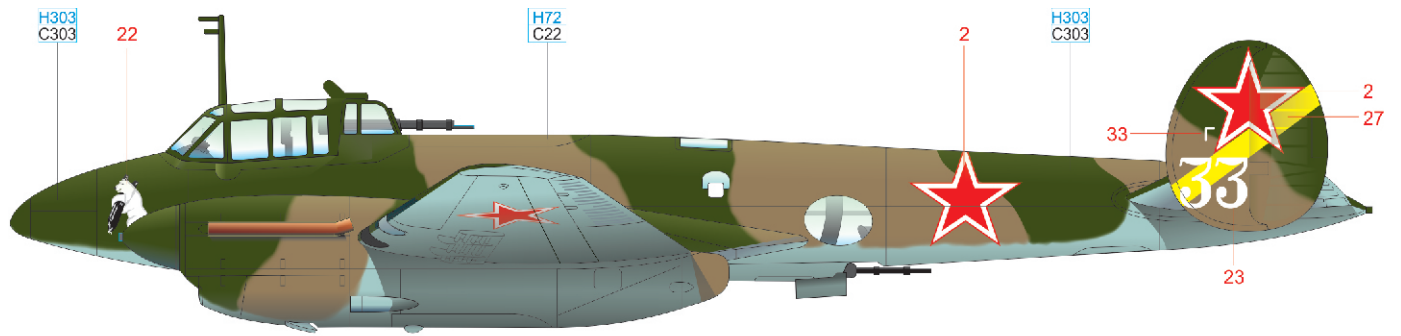

ČESKOU VERZI TEXTU NALEZNETE NA [www.eduard.cz](http://www.eduard.cz) POD KATALOGOVÝM ČÍSLEM 11112

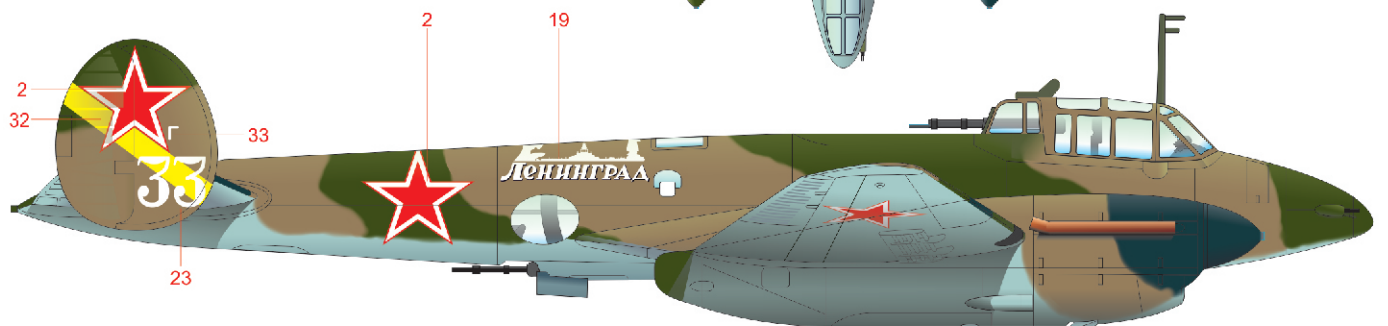

BROWN A-21m	H72 C22	GREEN A-24m	H303 C303	BLUE A-28m	H67 C115	GRAY A-32m	H331 C331
----------------	------------	----------------	--------------	---------------	-------------	---------------	--------------

# D Pe-2, later (post 205th) production batch, Generalmajor I. Polbin, CO of the 6th Bomber Aviation Corps, VVS RKKA, Germany, 1945

This aircraft was shot down over Breslau (currently Wrocław, Poland) on February 11th, 1945 by anti-aircraft artillery fire, claiming all crew members. Ivan Polbin made 158 flights and was twice nominated for Hero of the Soviet Union honours. The aircraft was painted in a nonstandard two-tone scheme consisting simply of the upper and side surfaces in matt Dark Green (A-24m enamel) with no disruptive pattern and with matt Light Blue (A-28m enamel) bottom surfaces. The front engine cowlings, rudder trim tabs, and rear parts of the spinners were painted in flat red. The tips of the spinners were flat white with red stars. The lion, the Guards Emblem, the Hero of the Soviet Union medal and the lightning bolt appeared on the port side only.

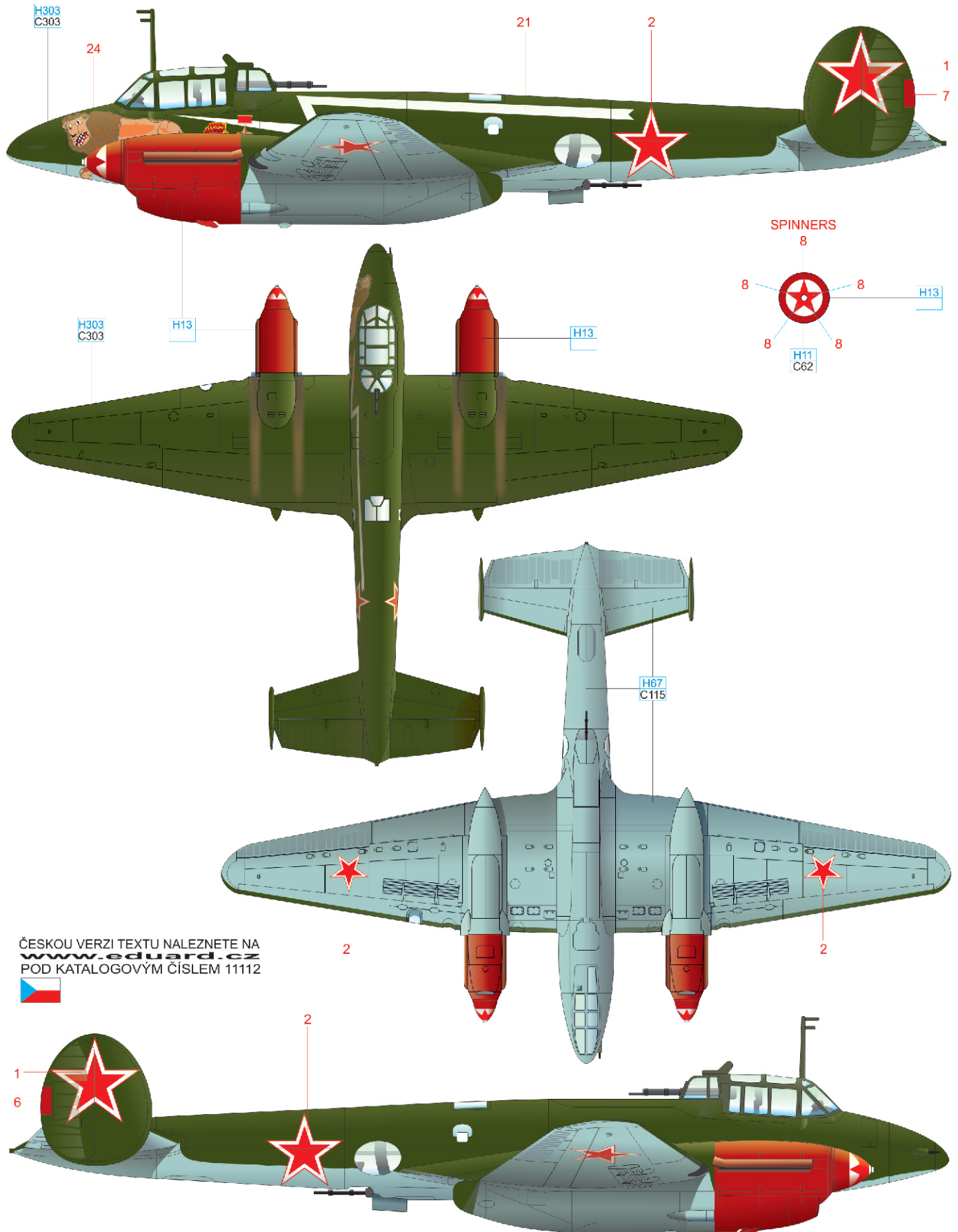

ČESKOU VERZI TEXTU NALEZNETE NA  
[www.eduard.cz](http://www.eduard.cz)  
 POD KATALOGOVÝM ČÍSLEM 11112



GREEN	H303	BLUE	H67	RED	H13	WHITE	H11
A-24m	C303	A-28m	C115				C62

# E Pe-2 later (post 359th) production batch, 1st Guards Bomber Air Division, VVS RKKA, Germany, 1945

This aircraft belonged to a squadron of Pe-2s financed by workers from the Trans-Baikal region. The aircraft was painted in accordance with the 1943 directives, position of camouflage colors is standard type No.1. The pike head and the Guards badge were placed on both sides of the fuselage, with the slogan appearing only on the port side.

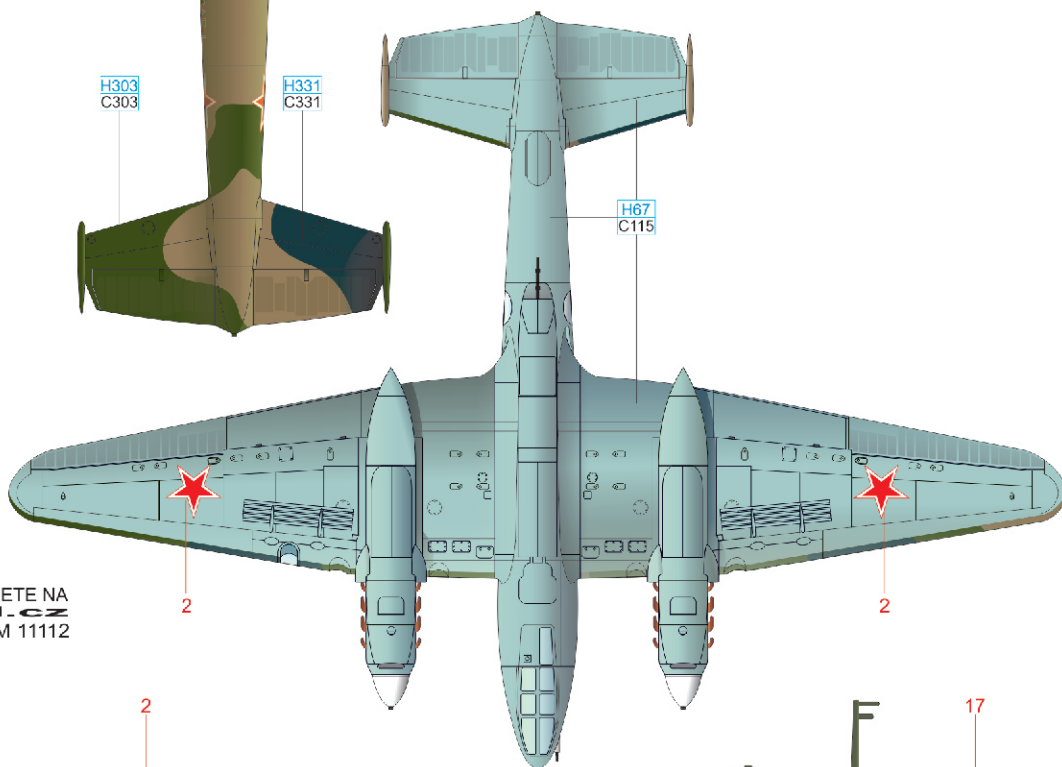
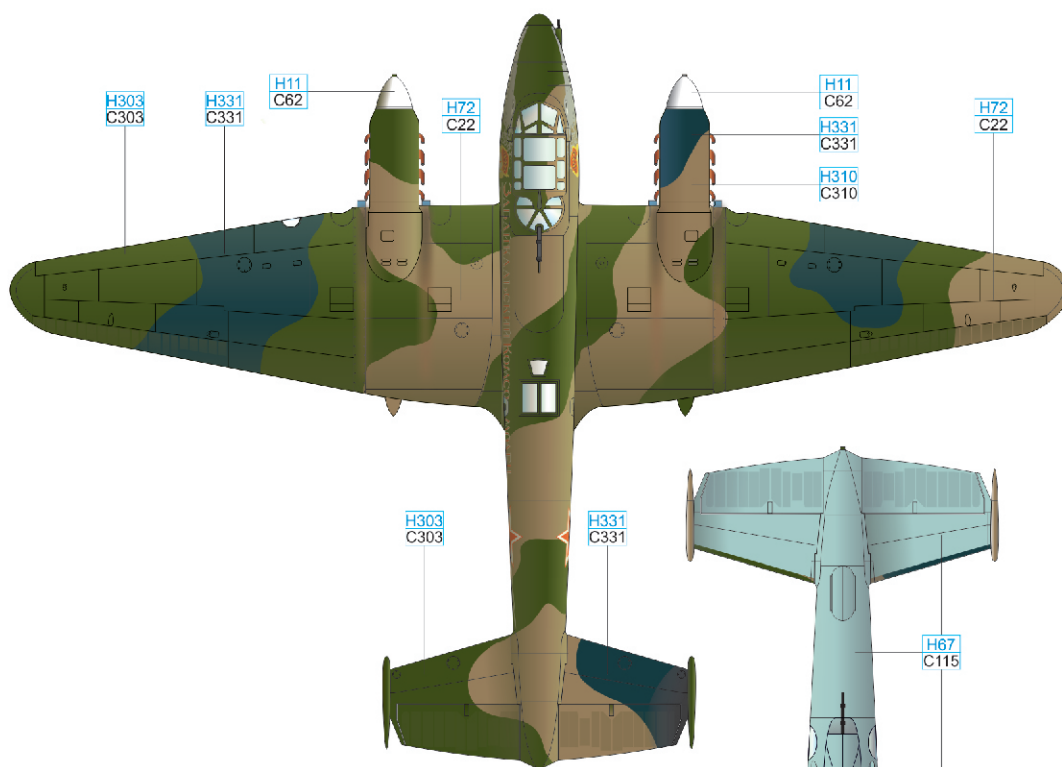
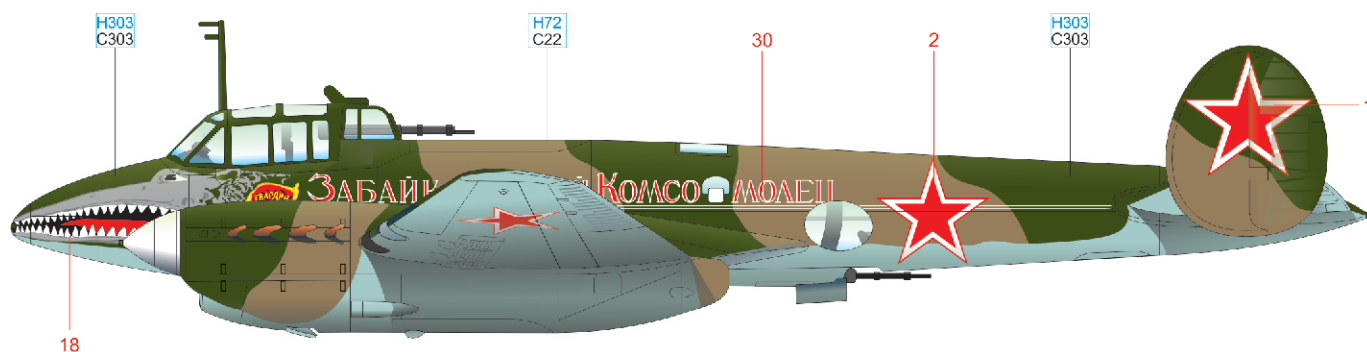

ČESKOU VERZI TEXTU NALEZNETE NA  
[www.eduard.cz](http://www.eduard.cz)  
 POD KATALOGOVÝM ČÍSLEM 11112

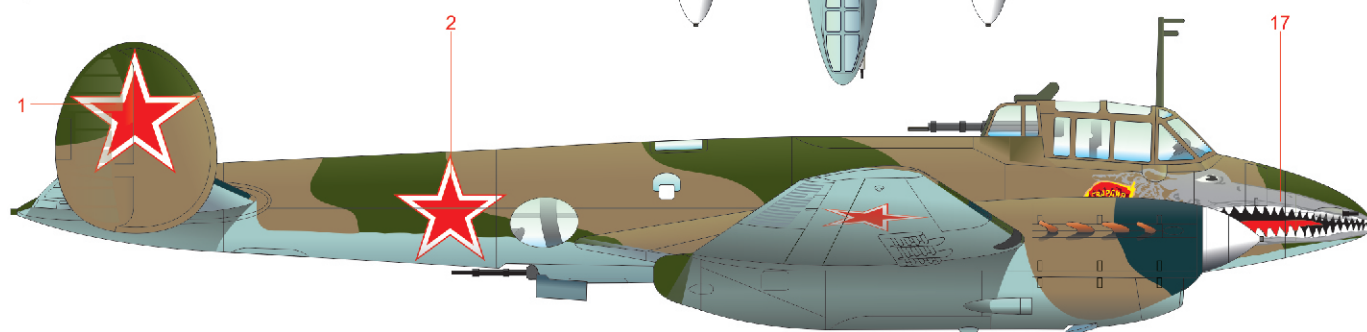

BROWN A-21m	H72 C22	GREEN A-24m	H303 C303	BLUE A-28m	H67 C115	GRAY A-32m	H331 C331	WHITE	H11 C62
----------------	------------	----------------	--------------	---------------	-------------	---------------	--------------	-------	------------



# Fw 190A-4

## 1/48

# #82142

## ProfiPACK

edition



## RELATED PRODUCTS:

- 48936 Fw 190A-4 landing flaps (PE-Set)
- 48937 Fw 190A-4 (PE-Set)
- FE863 Fw 190A seatbelts STEEL (PE-Set)
- 648351 Fw 190A-4 cockpit (Brassin)
- 648352 Fw 190A-4 engine (Brassin)
- 648354 Fw 190A-4 fuselage guns (Brassin)
- 648355 Fw 190A-4 engine & fuselage guns (Brassin)
- 648356 Fw 190A wingroot gun bays (Brassin)
- 648152 Fw 190 wheels early (Brassin) 2017/11

[www.eduard.com](http://www.eduard.com)

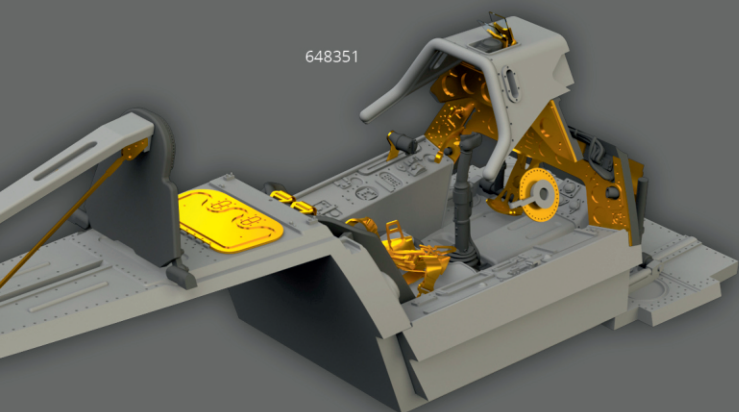

W. Nr. 746, Oblt. S. Schnell, CO of 9./JG 2, Vannes-Meucon, France, January 1943



Oblt. W. Nowotny, CO of 1./JG 54, Staraya Russa, Soviet Union, March 1943



Maj. J. Trautloft, CO of JG 54, Soviet Union, early 1943

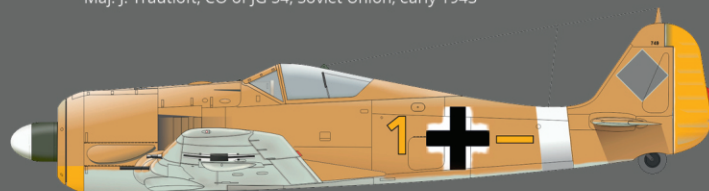

W. Nr. 749, Oblt. E. Rudorffer, CO of 6./JG 2, Sidi Ahmed, Tunisia, December 1942



W. Nr. 760, Fw. R. Eisele, 8./JG 2, Brest-Guipavas, France, January 1943

**eduard**