

1/32 scale

ITEM NO.:03217

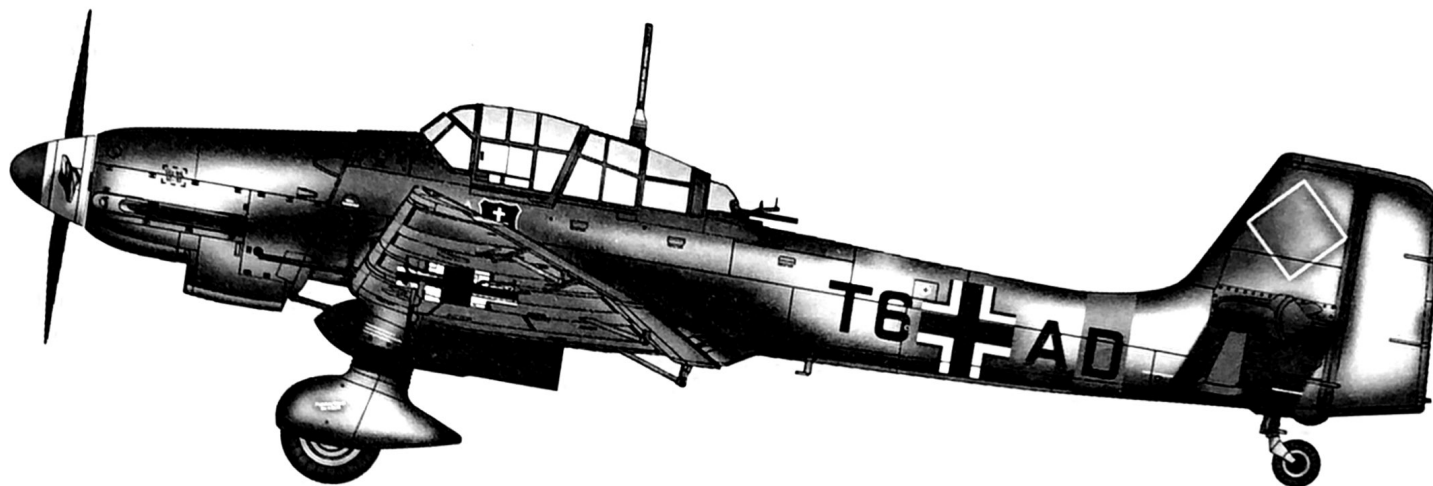

# Junkers Ju-87D Stuka

德国Ju-87D俯冲轰炸机

## READ BEFORE ASSEMBLY:

- This kit is not recommended for inexperienced modelers or for children under 14 years of age
- Study and understand these instructions thoroughly before beginning assembly
- When needed, remove photo-etch parts carefully using a modeling knife or photo etch sprue cutter, being careful not to damage or lose small parts.
- Take extra care in handling photo etch parts in order to avoid injury
- Apply instant cement sparingly to photo etch parts where instructed

- Tools recommended(not included in kit):Plastic and instant cements,sprue cutters,long nose pliers,,modeling knife, small files, tweezers, pin vise & scissors. Soft cloth and sandpaper will also assist in construction
- Glue and paint are not included in the kit. Use plastic cement and hobby paints only. Color guide for purchasing paint is included in the kit.
- Keep out of reach of small children. They must not be allowed to ingest small parts or handle plastic bags in any way.

## 装配之前仔细阅读

- 小心用模型锉刀锉平所有零件表面的注射浇口。
- 小心用刀片切下蚀刻片零件，不要遗失小零件。
- 用强力快干胶水粘合蚀刻片零件和金属轴。过量的快干胶水使用可能导致可动零件会粘住，小心涂胶。
- 取蚀刻片时应特别注意安全，防止利边划伤手指。
- 某些零件表面需贴水上贴纸，请选择在装配的同时进行。
- 推荐模型工具(自备)：胶水，水口剪刀，长咀钳，刀片，锉刀，镊子钳，钻，剪刀，瞬间快干胶。
- 软布同砂纸同时也应该是必备工具。
- 请使用塑料胶水和油漆，模型内不含。
- 谨防小孩吸吮塑料零件，或者将塑料袋套在头上，制作时应将套材远离小孩接触。
- 本产品不适合14岁以下没有经验的模型爱好者。

## 水贴纸的使用:

- 从水贴纸上剪下印花;
- 将印花放入温水中浸10秒, 然后放在干净布上.
- 拿着印花纸板将印花移到模型上;
- 手指蘸水将印花移到适当的位置;
- 用软布轻压印花直至水干, 气泡消失.

## DECAL APPLICATION:

1. Cut decals from sheet as needed
2. Dip the decal in warm water for about 10 seconds and then place on soft clean cloth.
3. Hold the decal backing sheet edge and gently slide the decal onto the model in its proper position.

4. While still wet,decal can be adjusted for better fit on model by dampening it gently with your finger.
5. When placed in the proper position,gently press decal down with a soft cloth until excess water and air bubbles are gone.
6. Allow decal to dry completely before handling model



部品图  
Parts

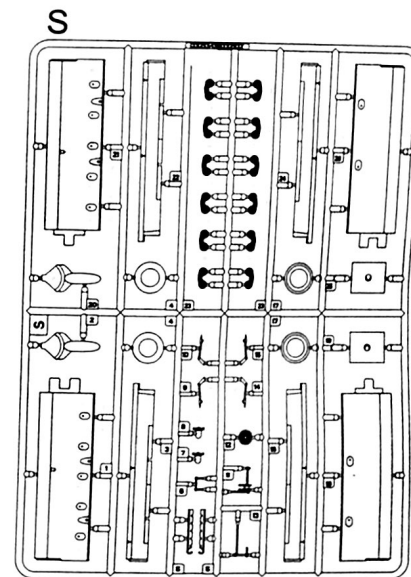
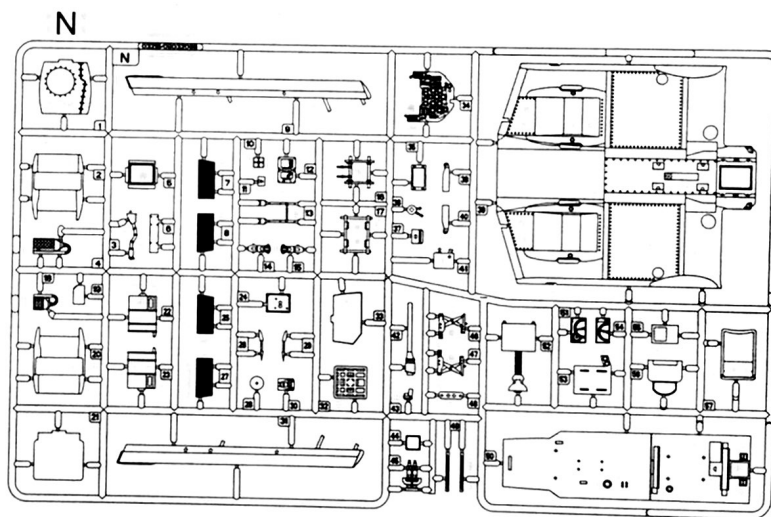
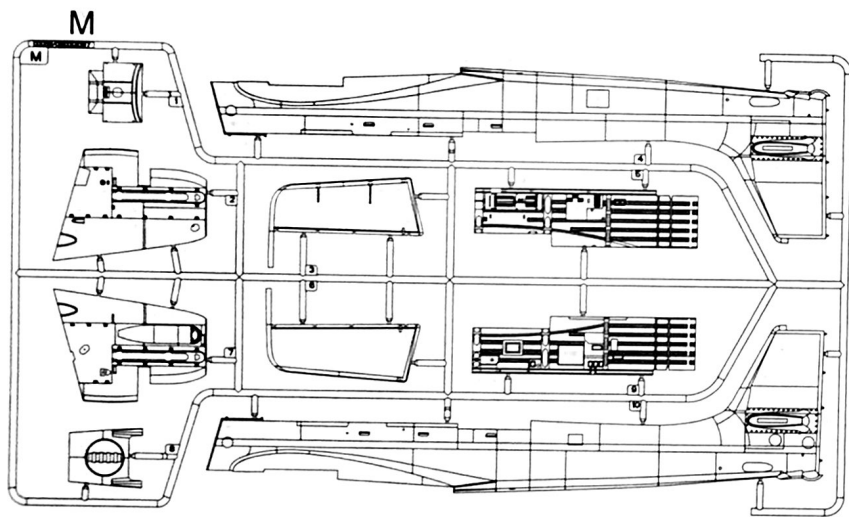
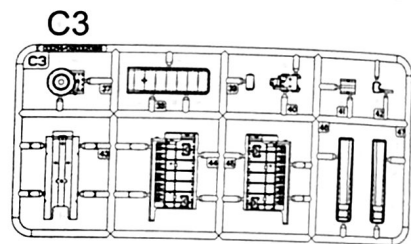
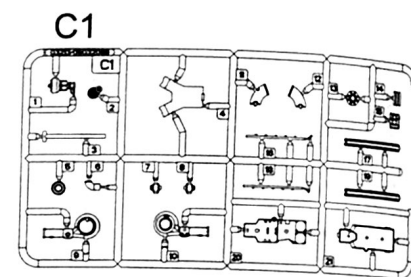
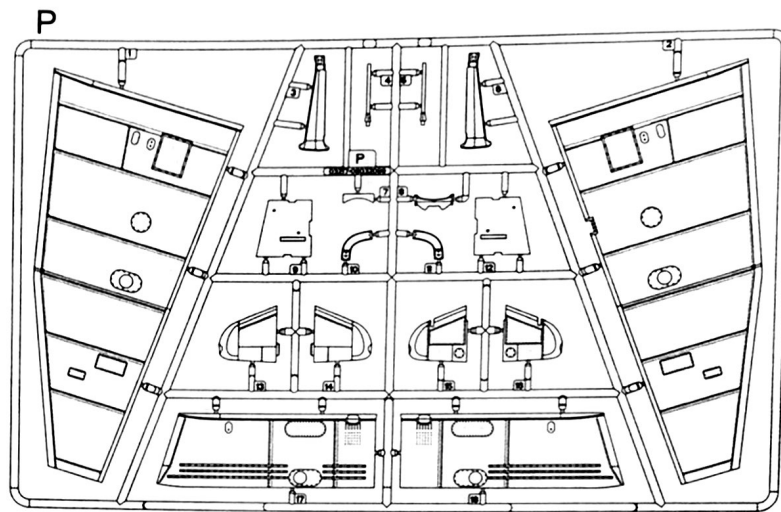
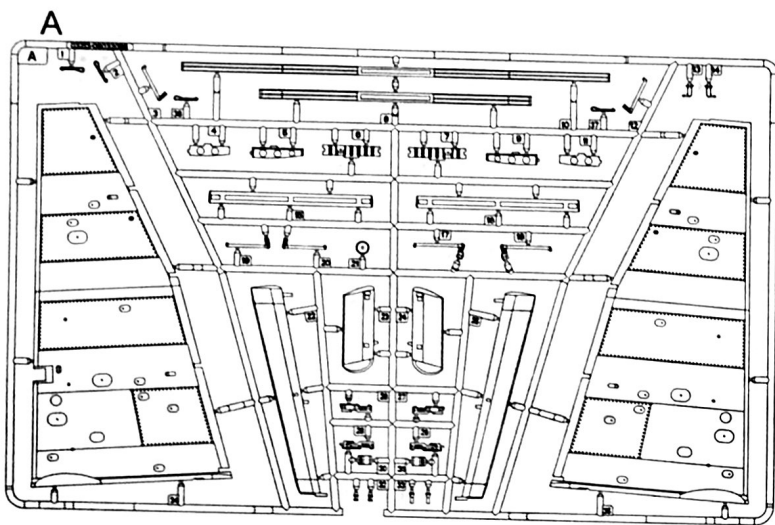

部品图  
Parts

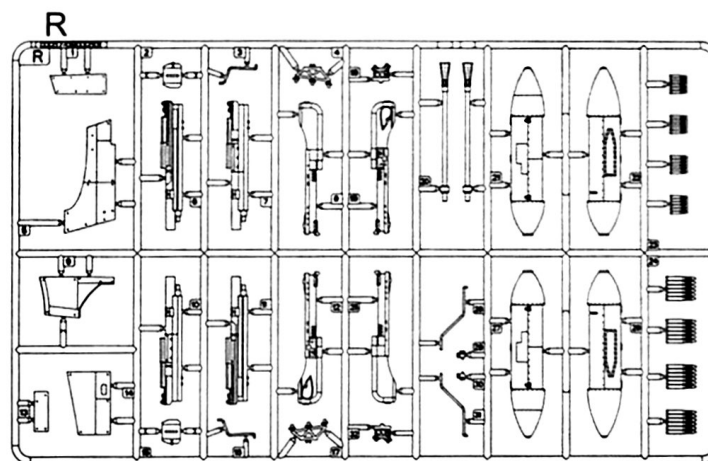
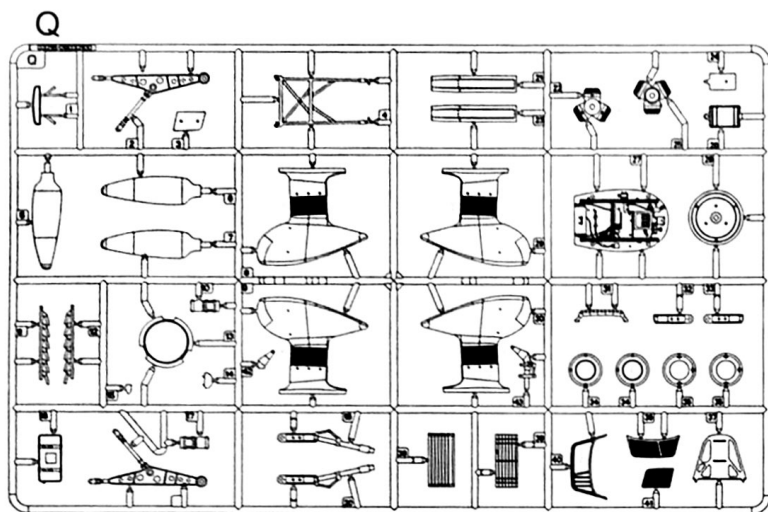

《主轮胎》X2  
Main tyre



《尾轮胎》  
Tail tyre

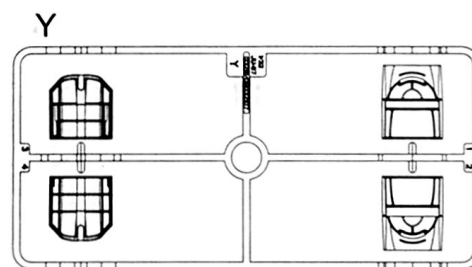
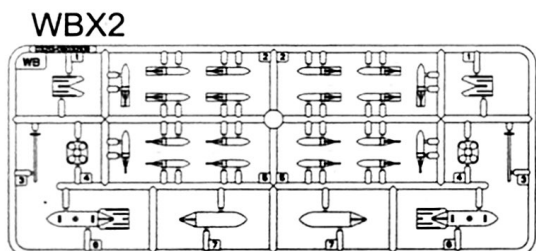
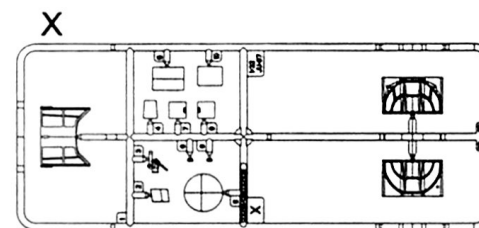
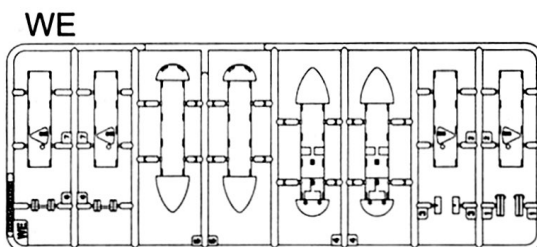
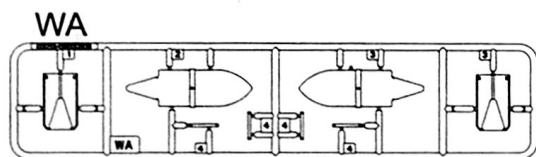

《蚀刻片》A  
Photo etched part (PE)



《水贴》  
Decal

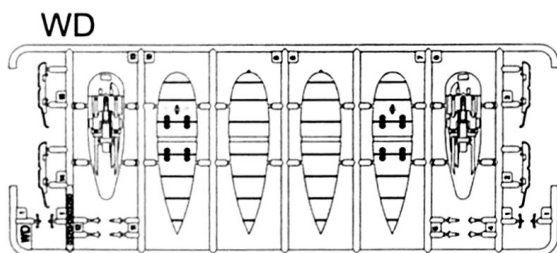

《蚀刻片》B  
Photo etched part (PE)

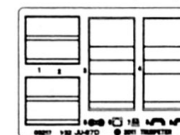

不用的部件:  
Unused parts  
A15 A16 A32 S23 Q34 Q35 R2 R3 R4 R6  
R7 R8 R10 R11 R12 R15 R16 R17 R18 R19  
R20 R21 R22 R23 R24 R25 R26 R27 R28 R29  
R30 R31 R32 PE-A2 PE-A3 PE-A4 PE-A5  
PE-A6 PE-A7 PE-B1 PE-B2 PE-B3 PE-B4 PE-B6  
PE-B8 PE-B9 Y1 X7 X9 X12

1

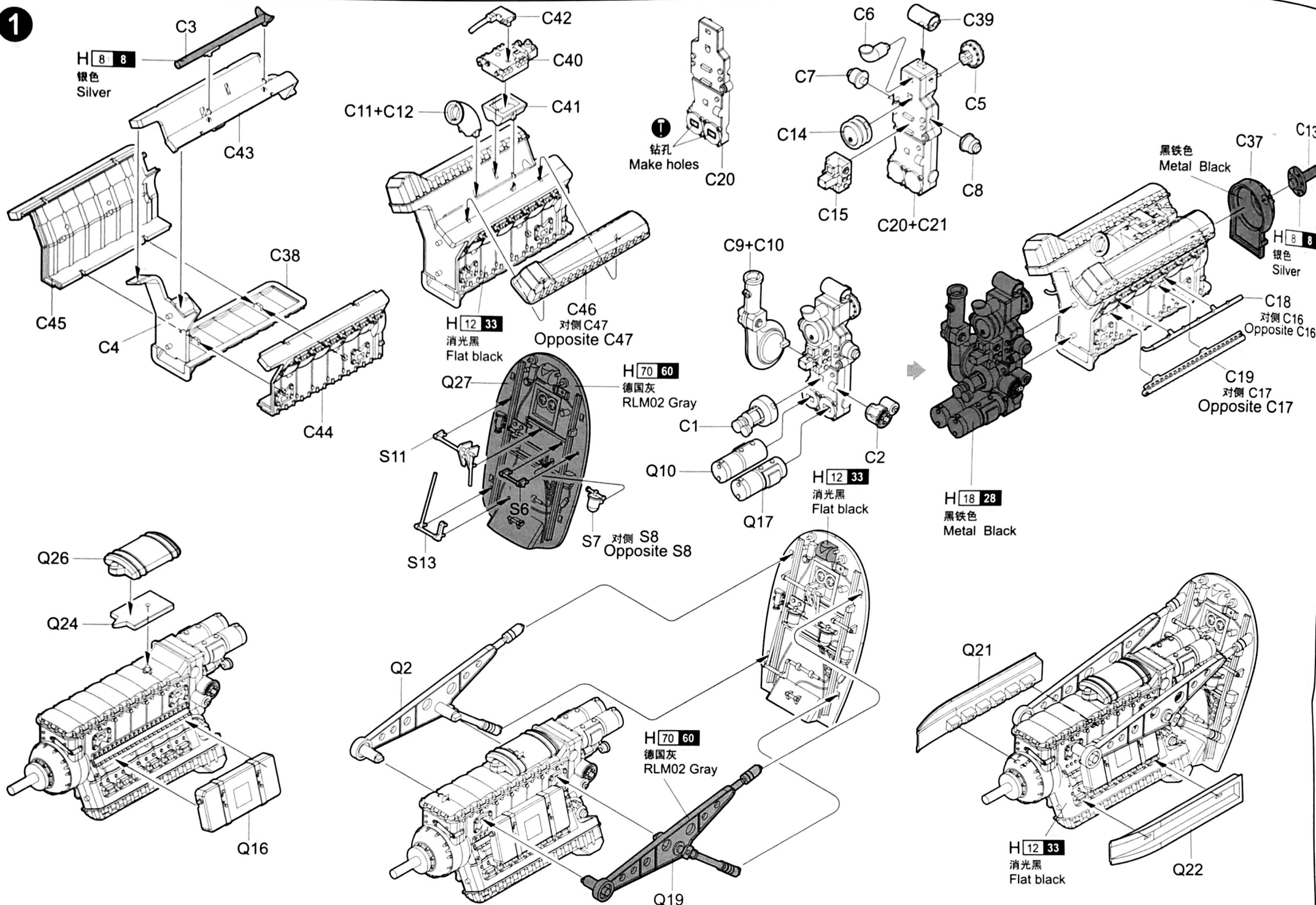

2

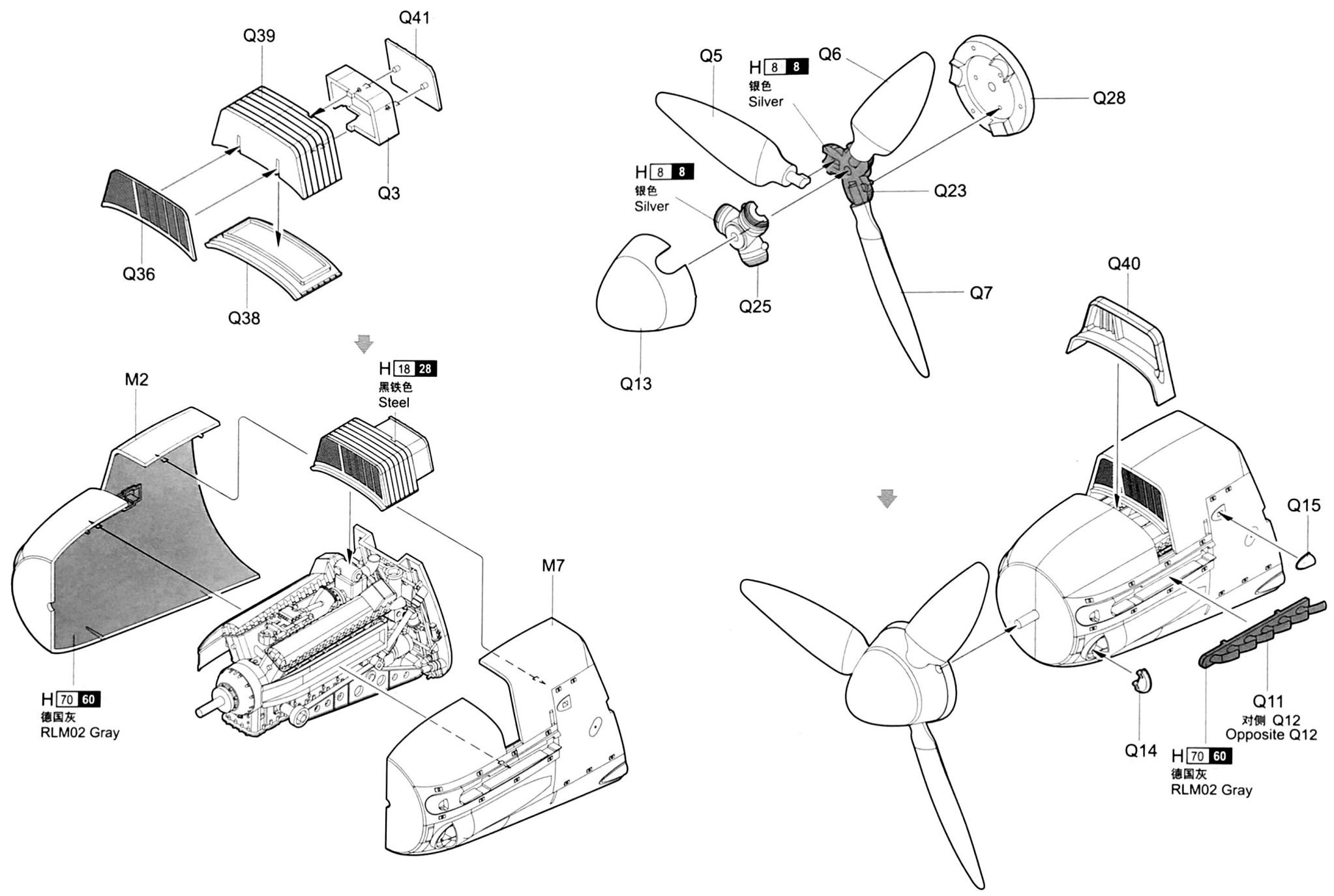

3

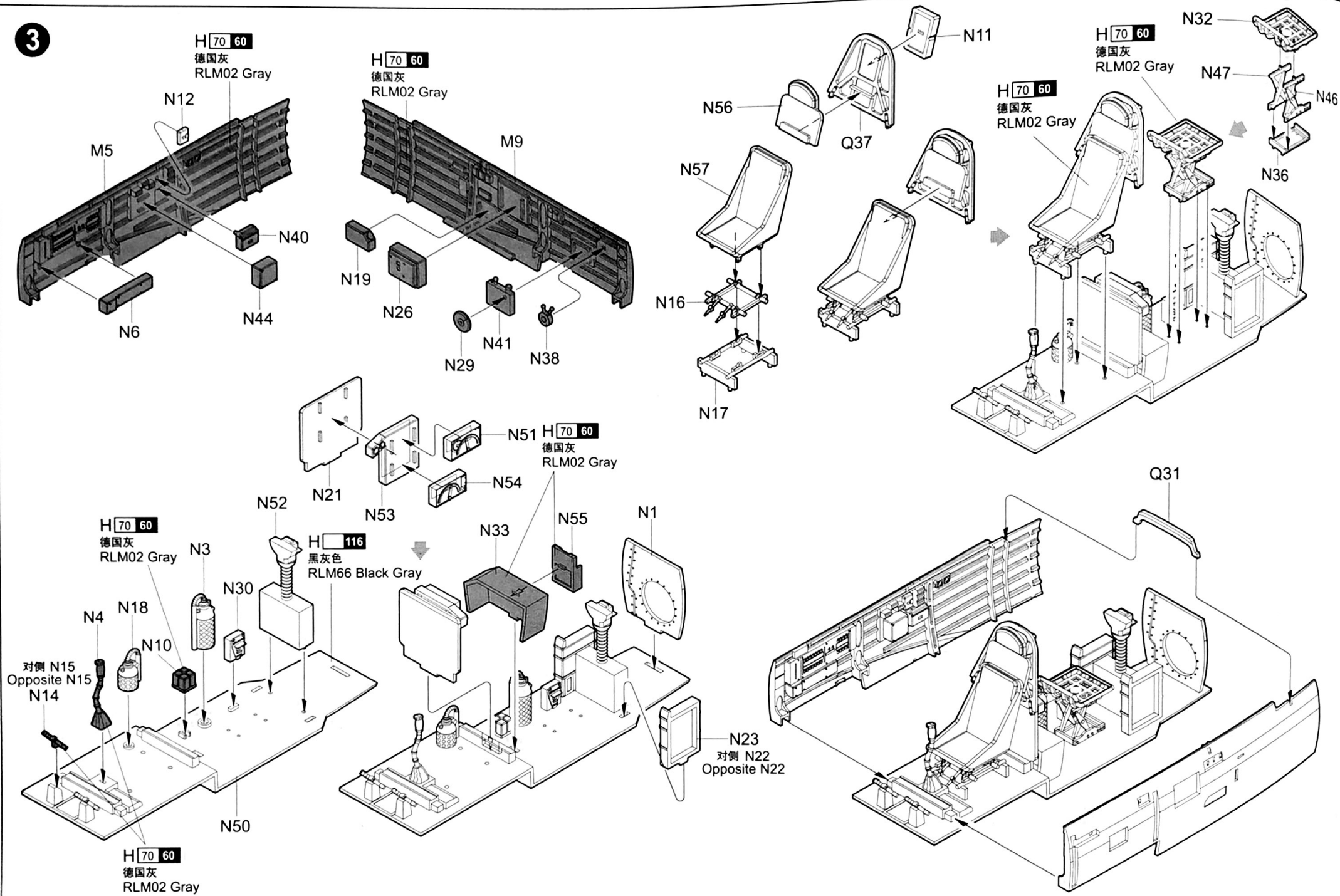

4

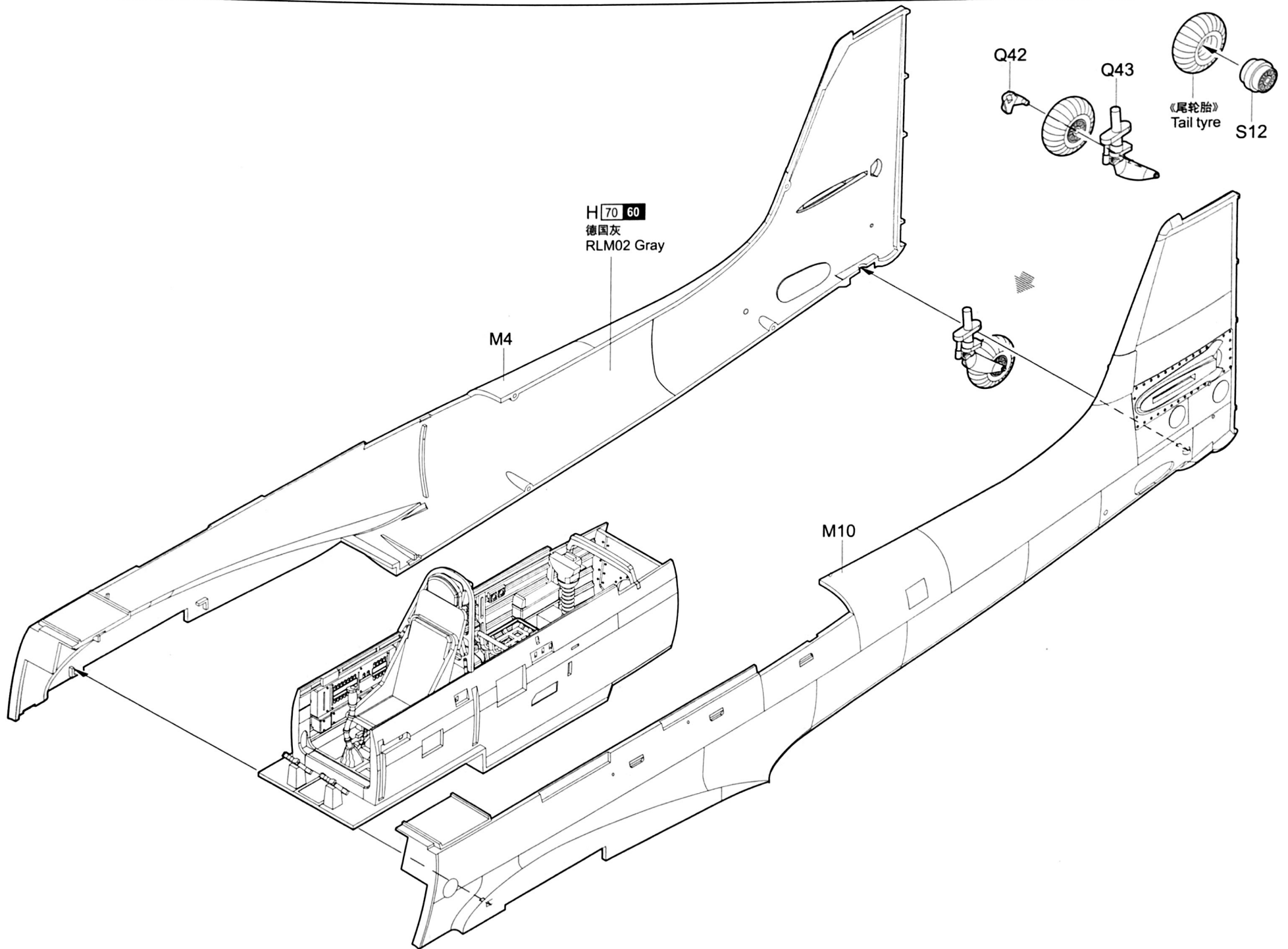

5

《左侧水平尾翼》  
Left horizontal stabilizer

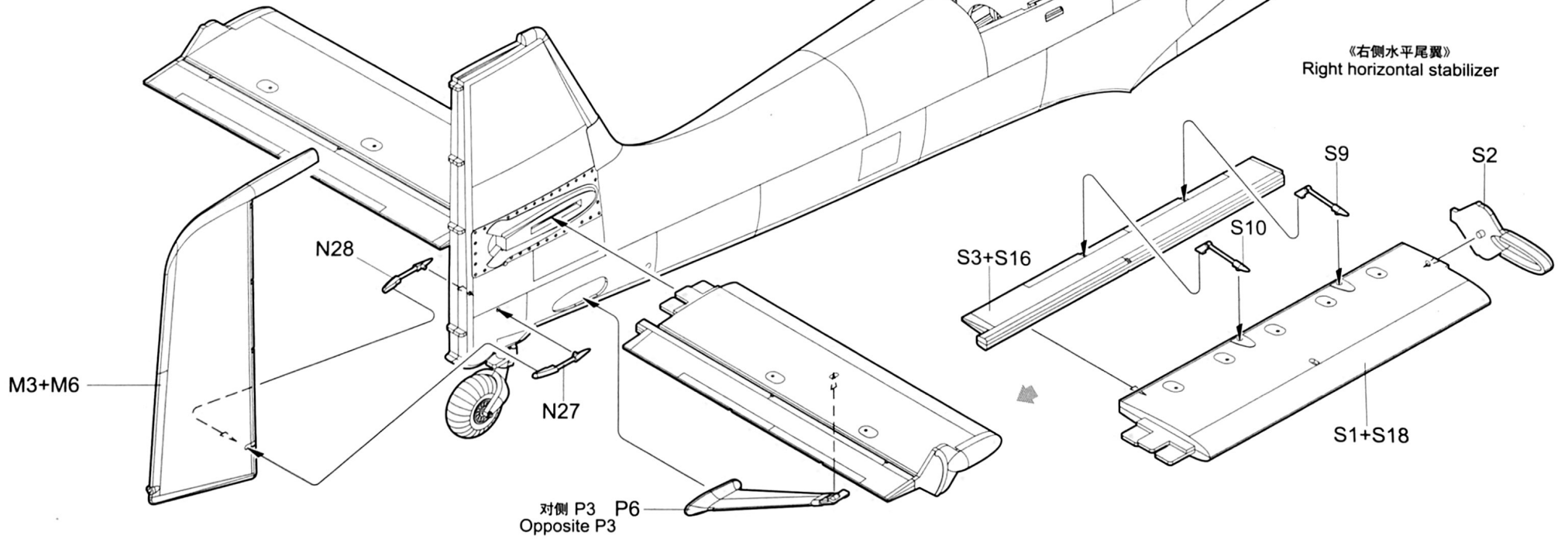
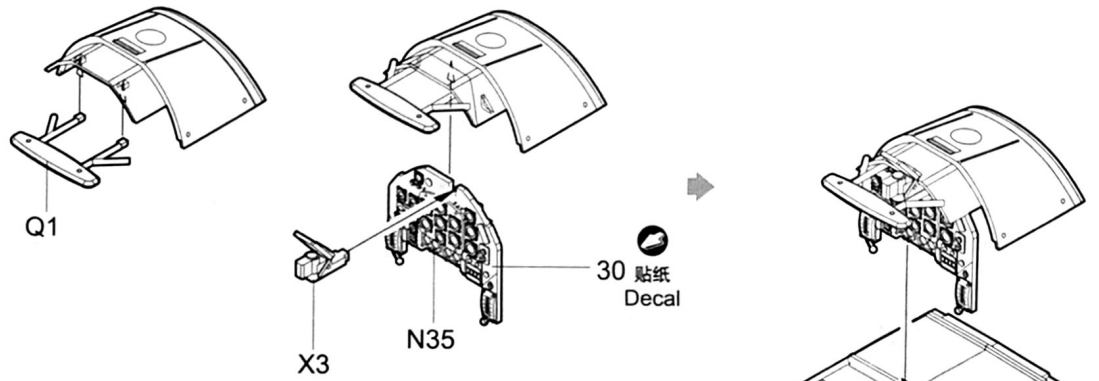
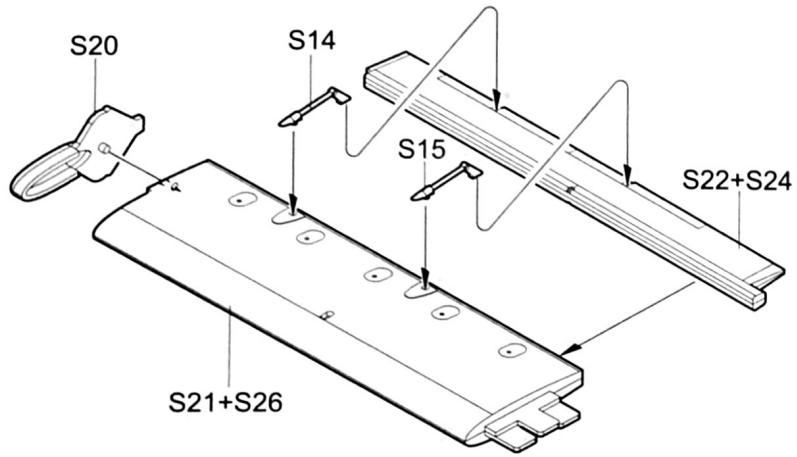



6

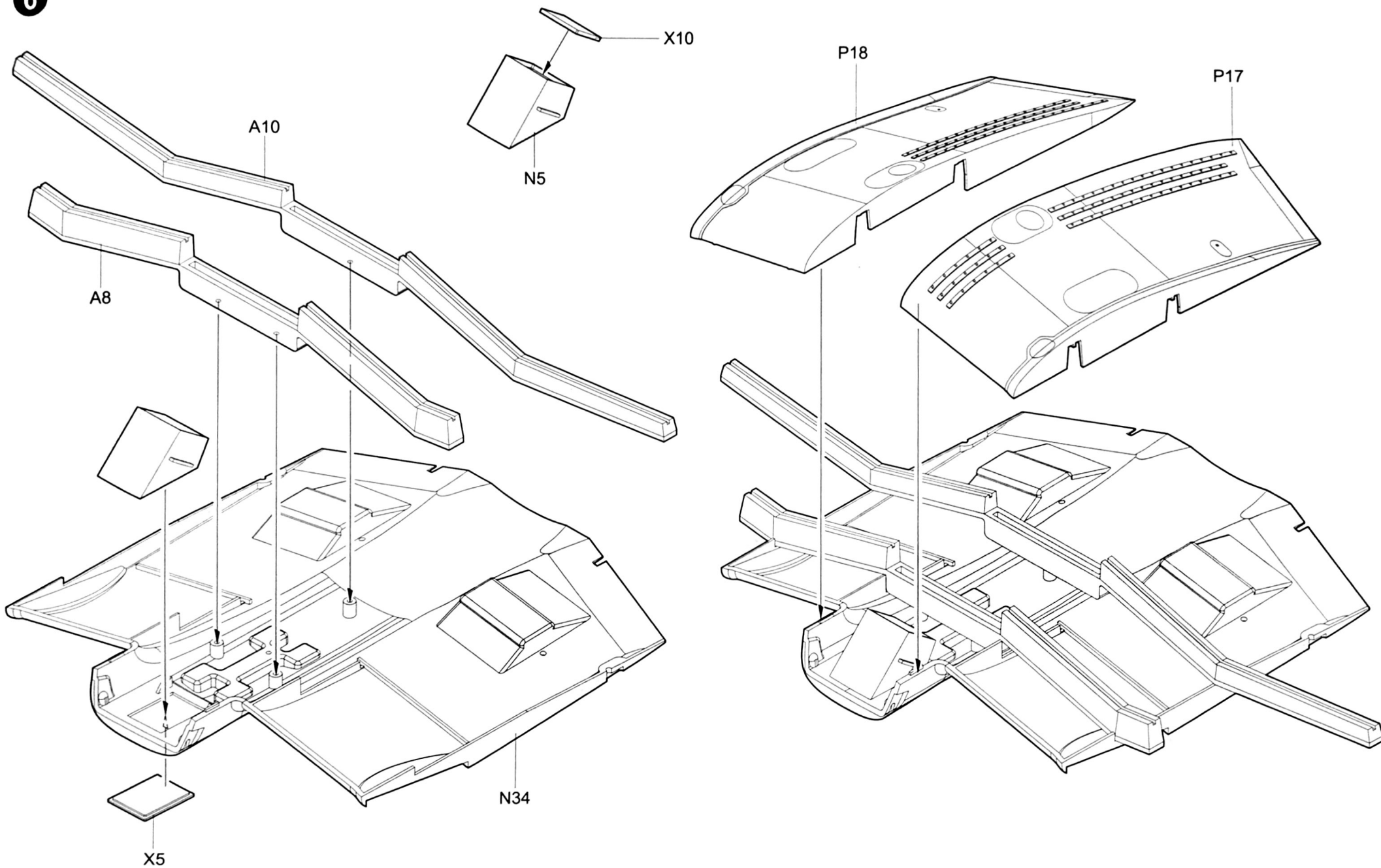

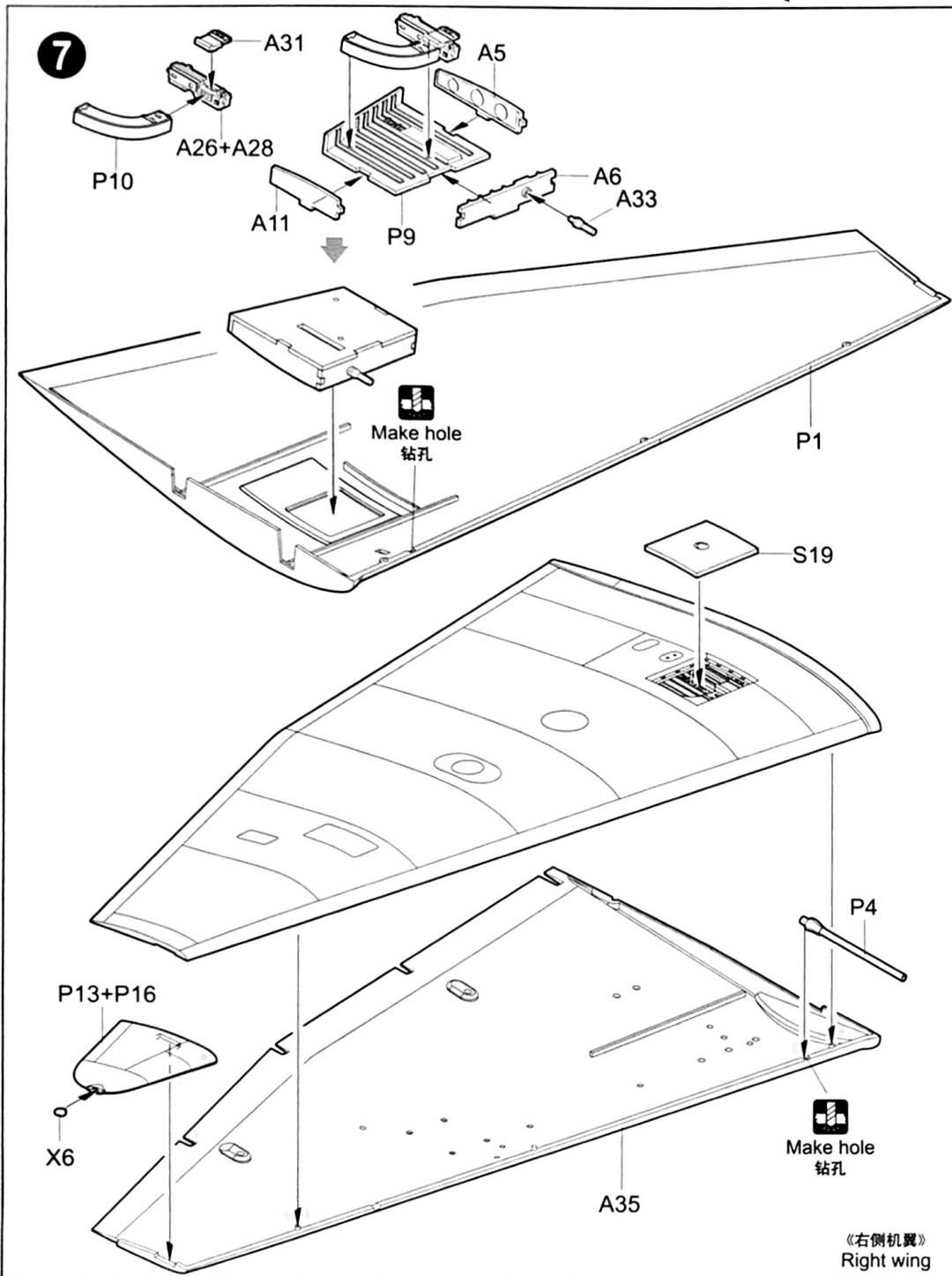

03217

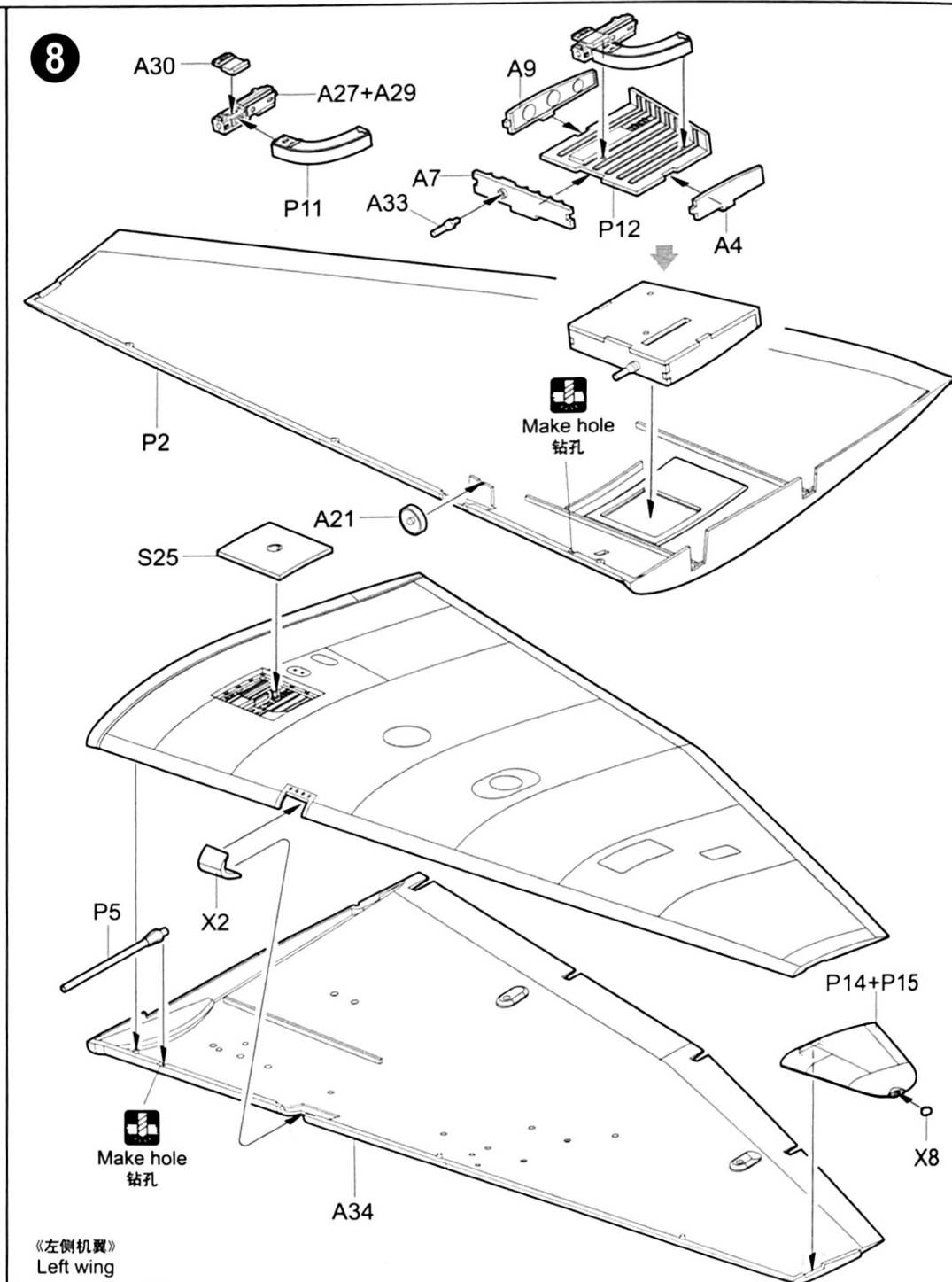

10

9

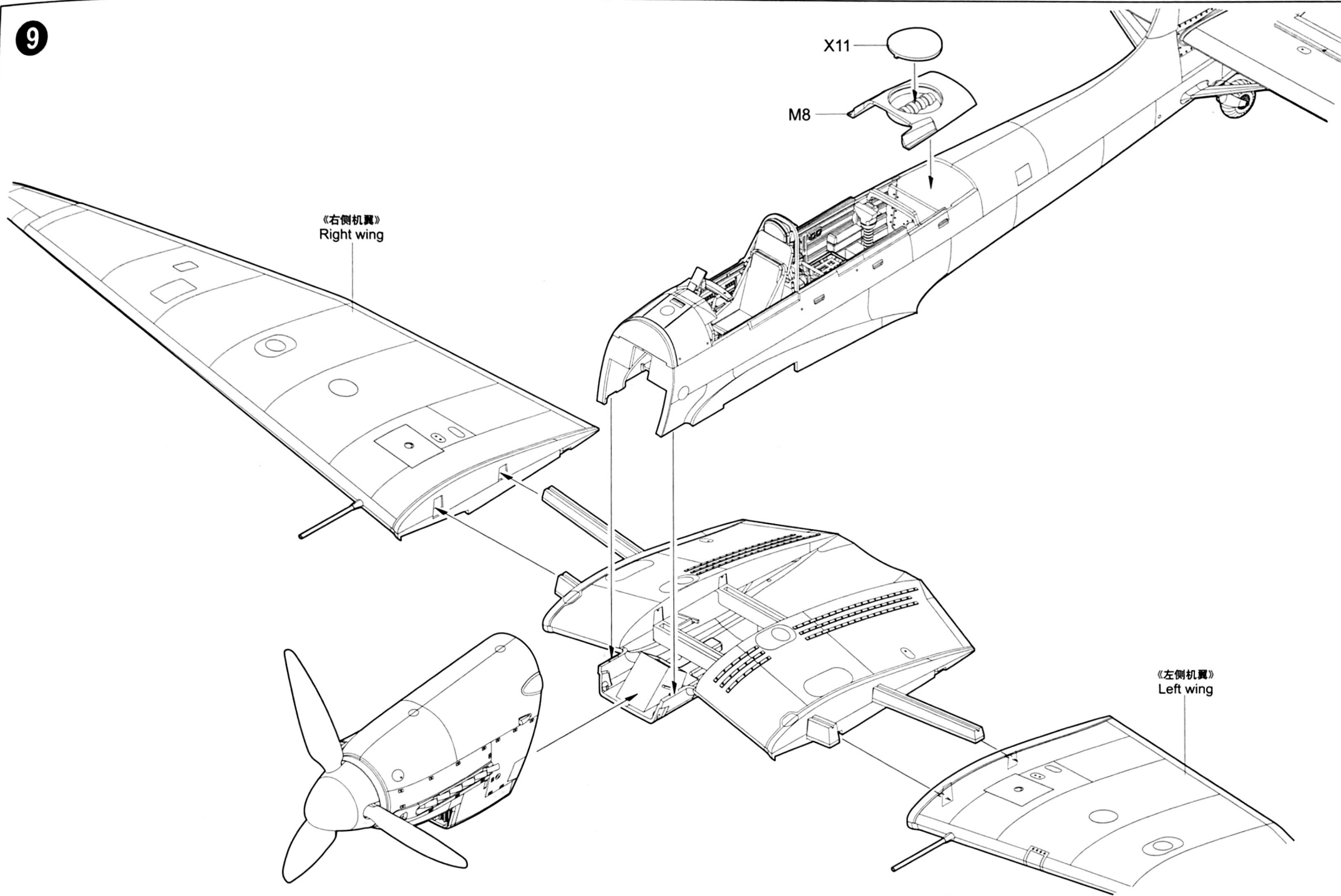

《右侧机翼》  
Right wing

《左侧机翼》  
Left wing

X11

M8

10

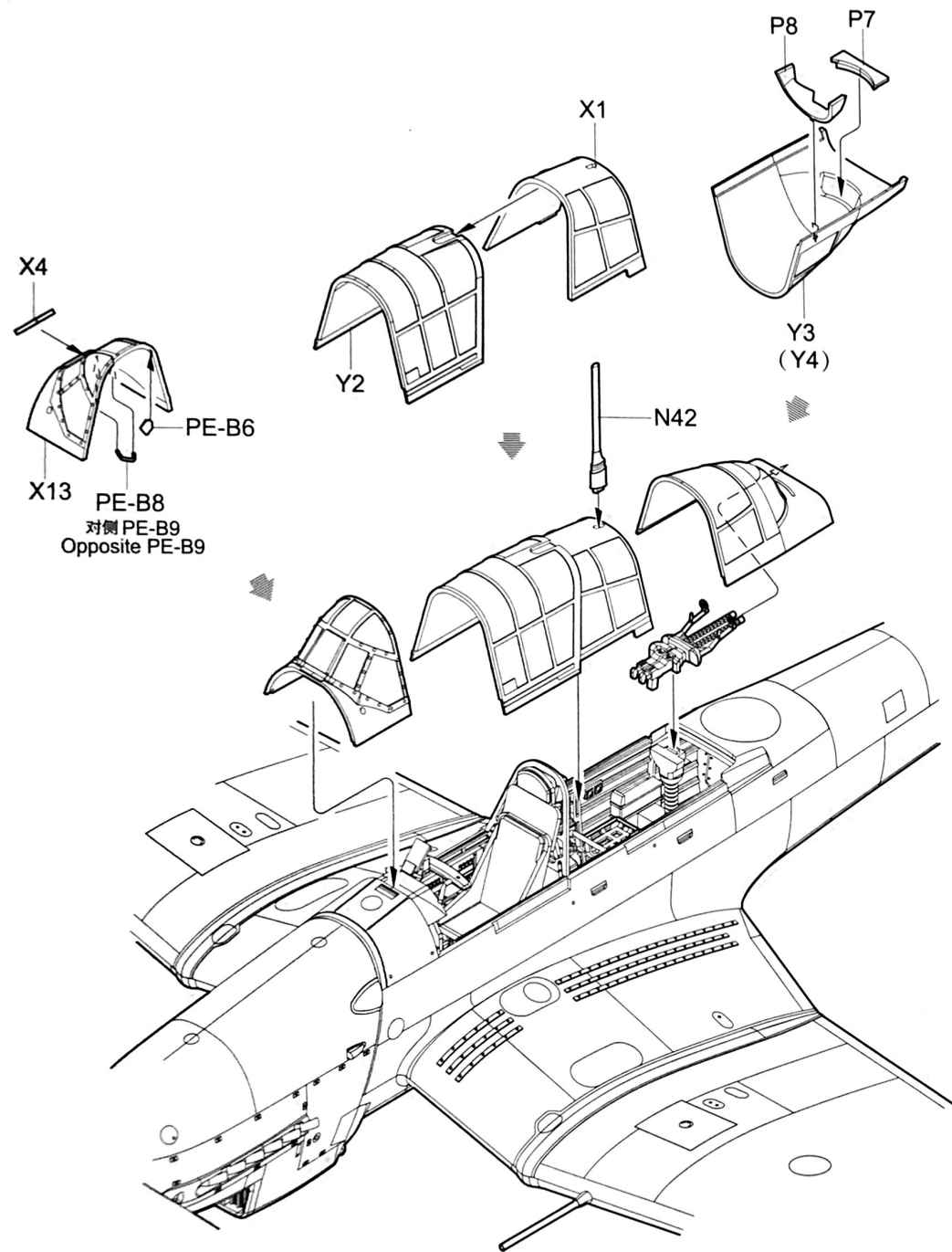

11

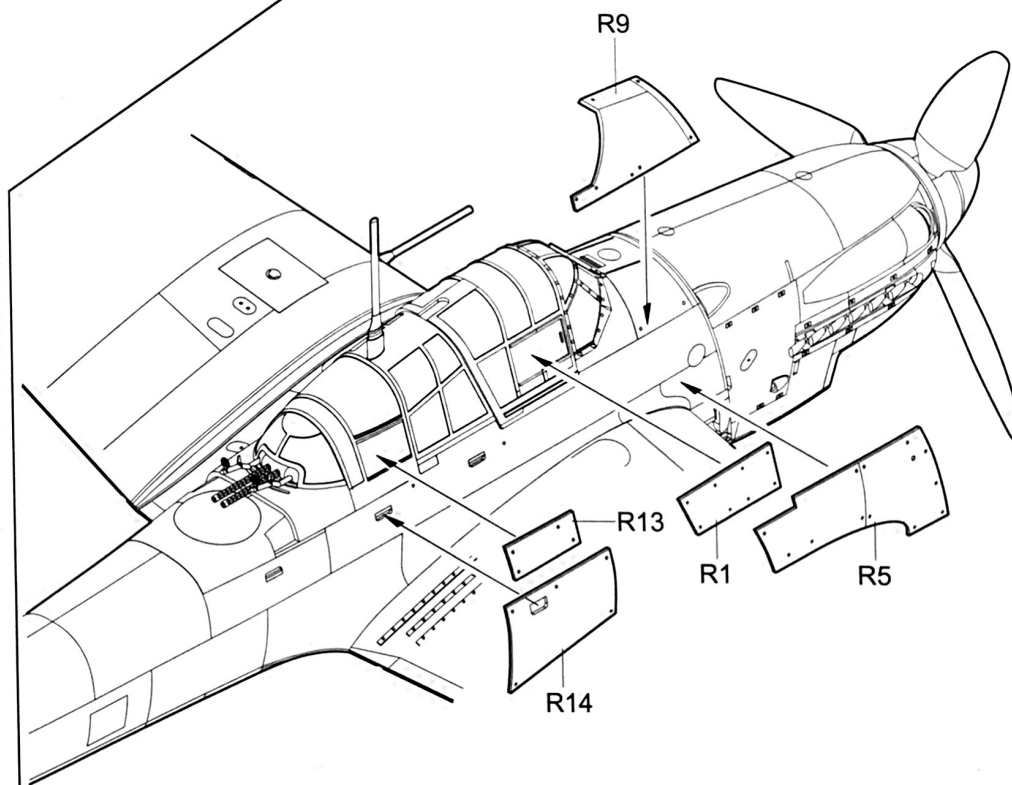
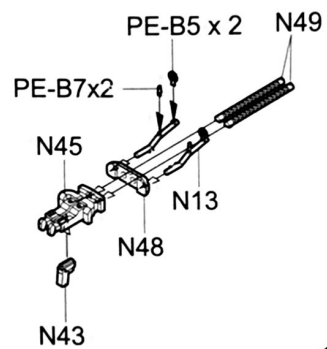

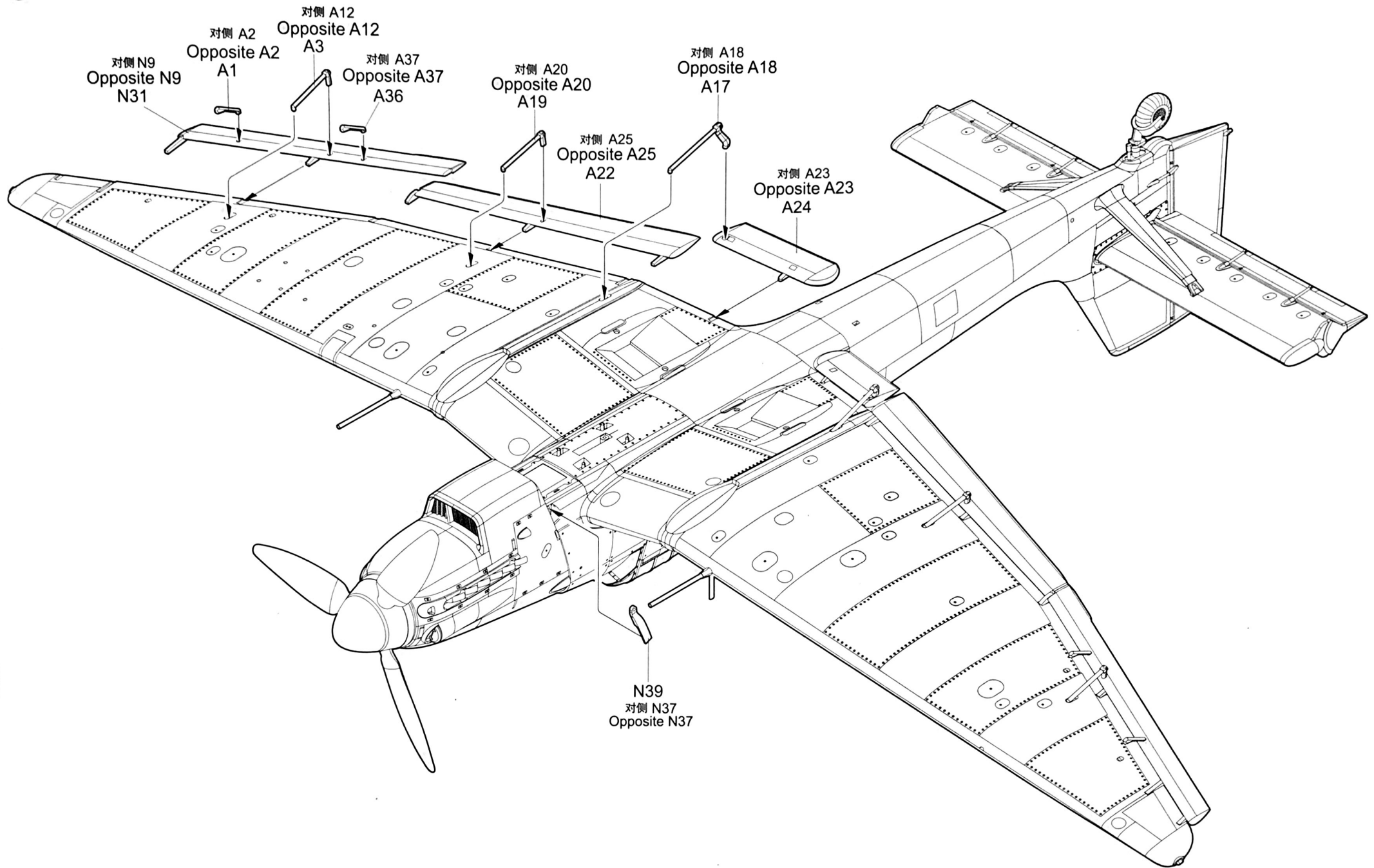

13

《主轮胎》  
Main tyre

《左侧主起落架》  
Left main undercarriage

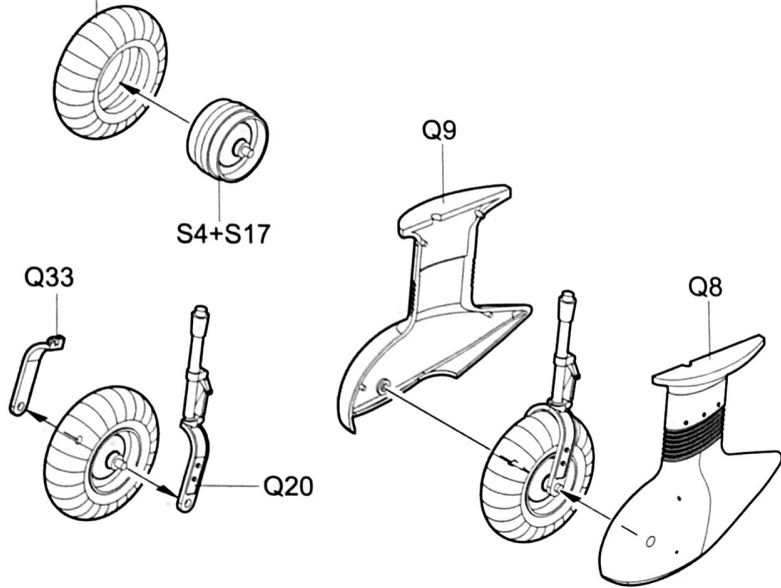

14

S4+S17 《主轮胎》  
Main tyre

《右侧主起落架》  
Right main undercarriage

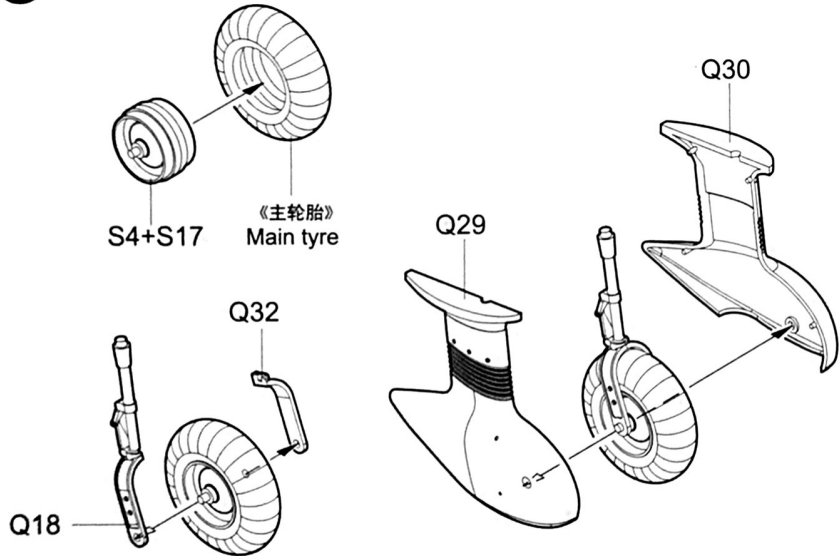

15

《左侧主起落架》  
Left main undercarriage

N2 对侧 N20  
Opposite N20

对侧 N24+N25  
Opposite N24+N25  
N8+N7

对侧 A14  
Opposite A14  
A13

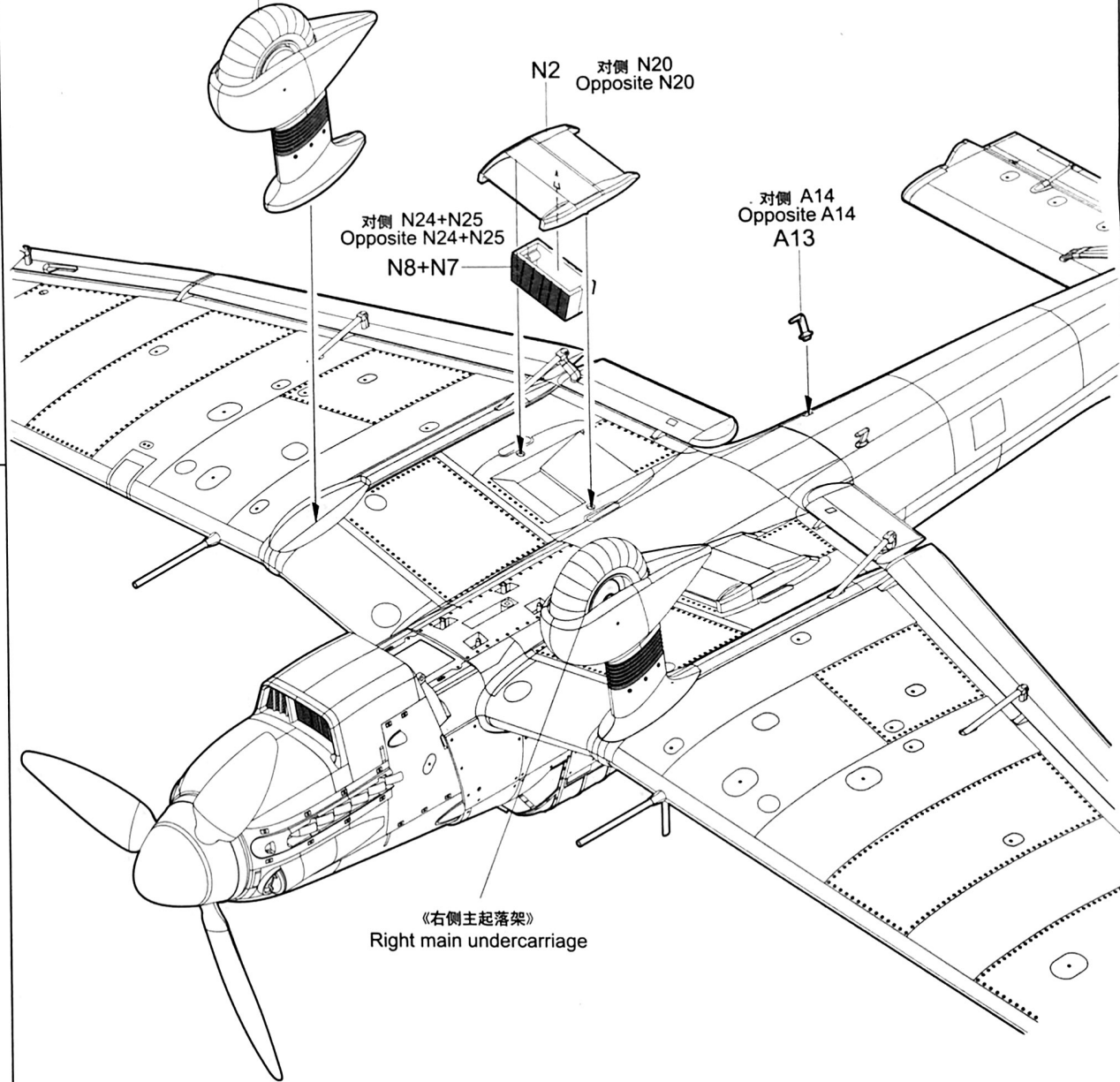

《右侧主起落架》  
Right main undercarriage

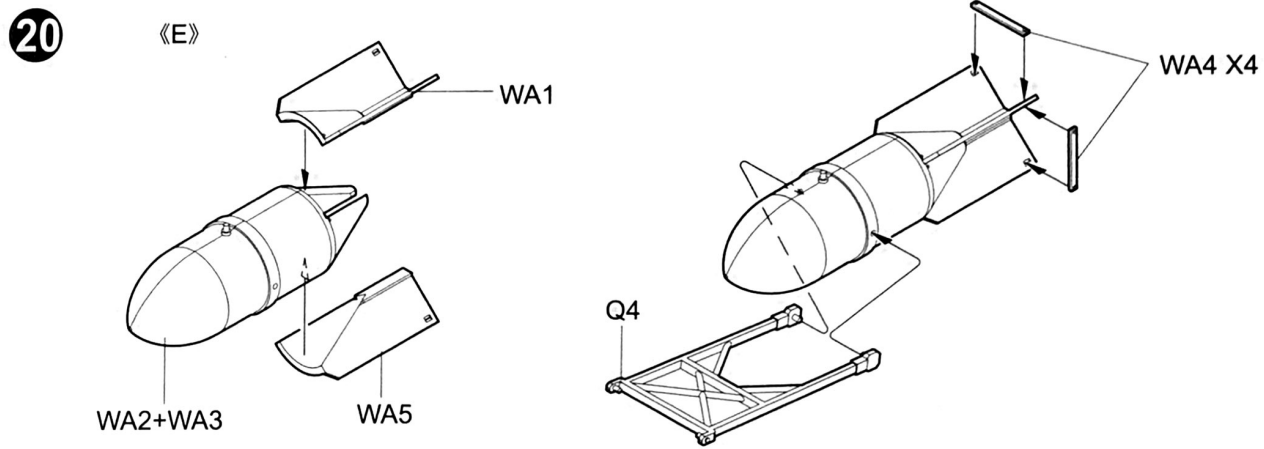
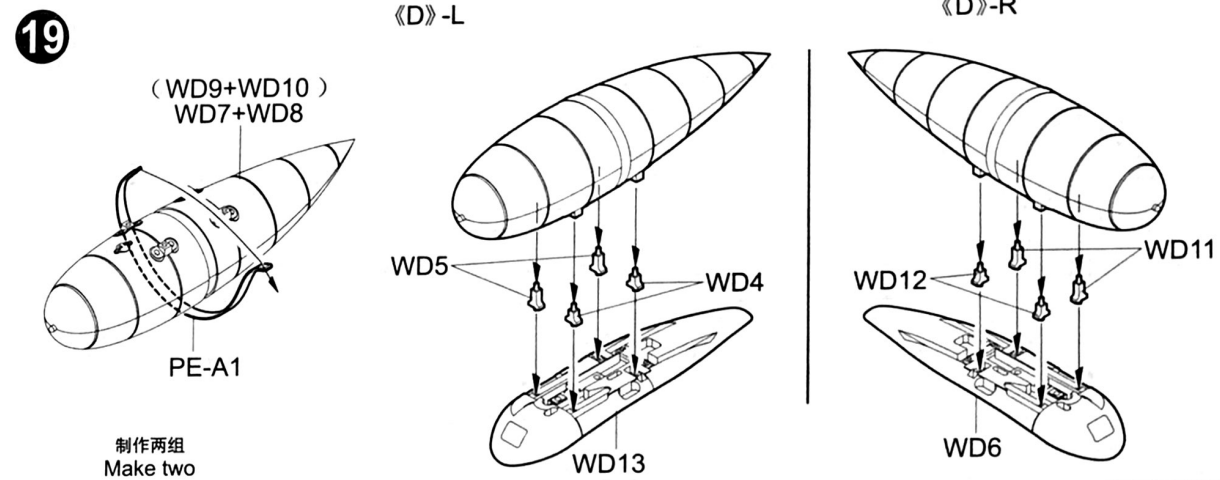
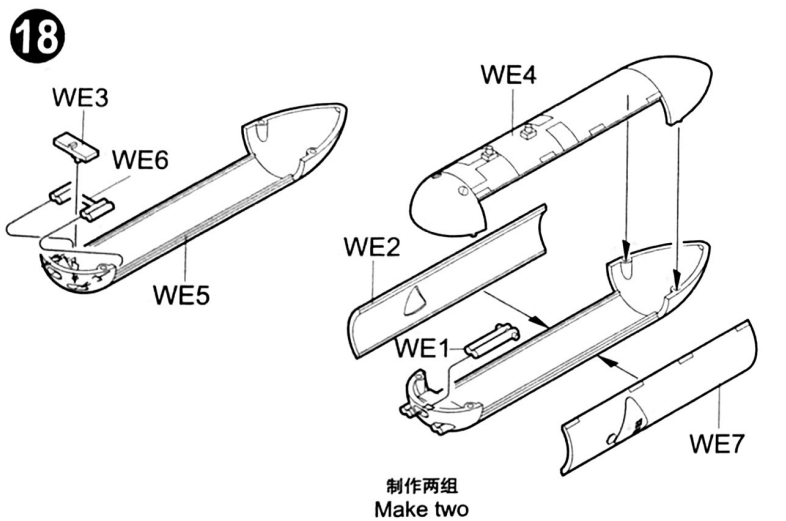
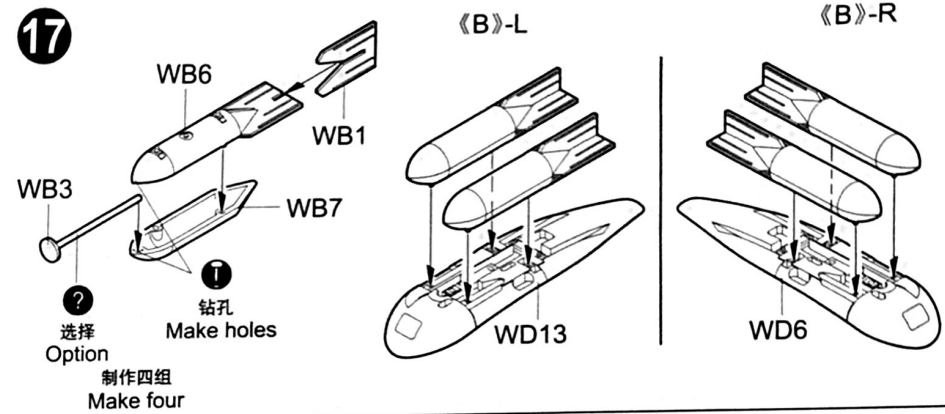
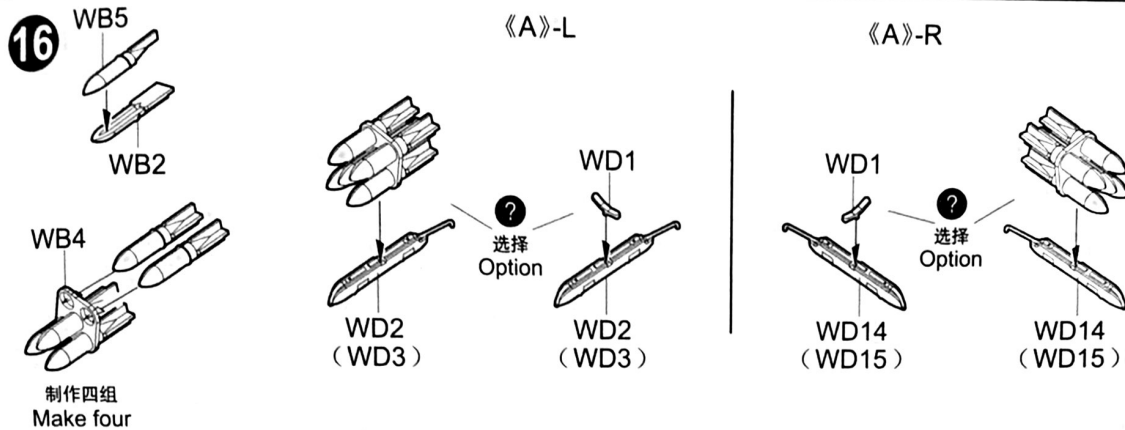

21

