

Special
HOBBY MPM
Production

Azur

limited run plastic kits

High quality injected plastic kits - short run/ Vstříkované modely - limitovaná série

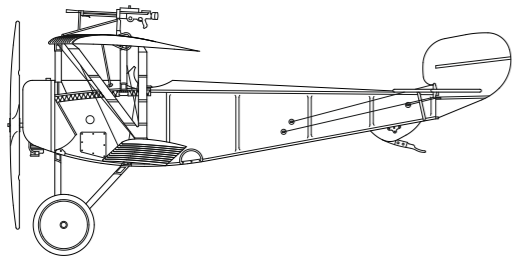

SH32015 Nieuport Nie 11 "French aces" 1/32

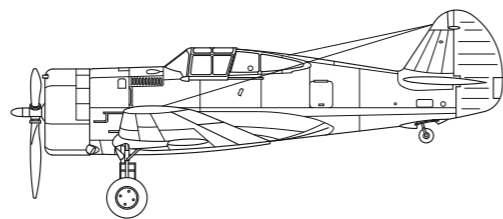

1/32

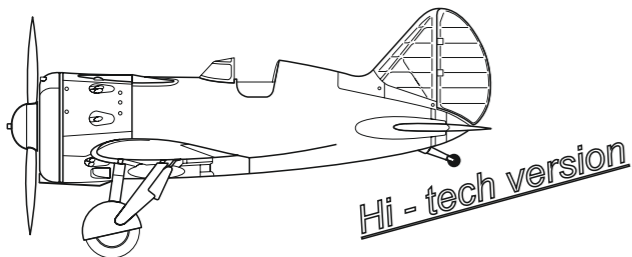

SH32018 I-16 type 24 1/32

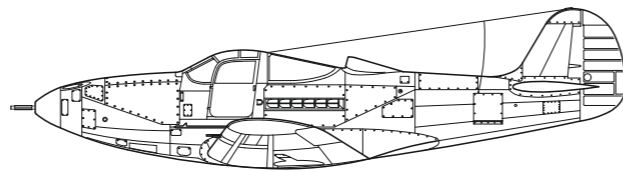

1/32

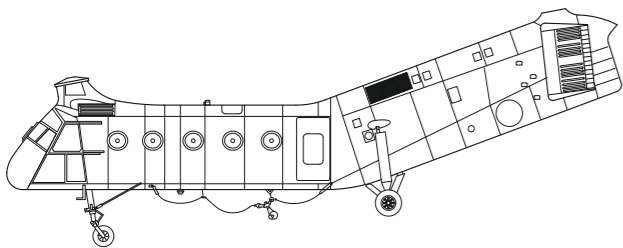

SH48062 H-21 Shawnee 1/48

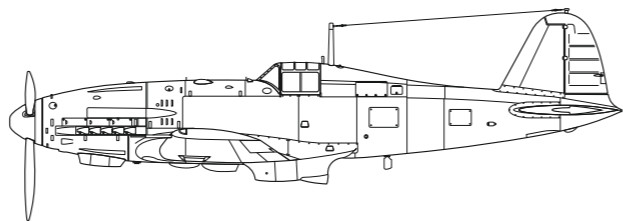

SH48066 Fiat G.55 Centauro Sottoserie 0 1/48

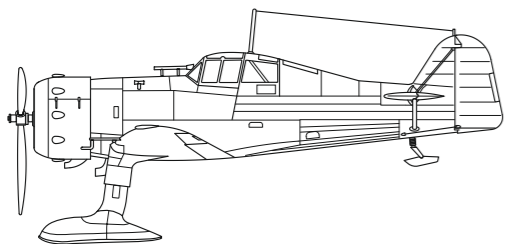

SH48078 Fokker D.XXI 1/48

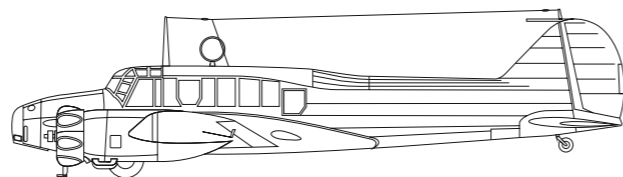

SH48081 Avro Anson Mk.I 1/48

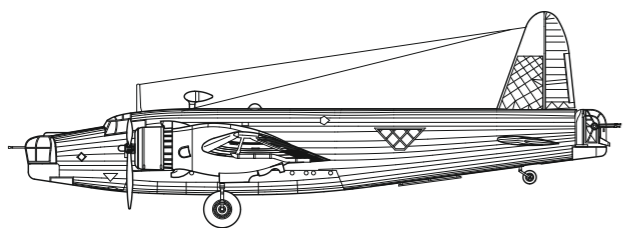

72542 Vickers Wellington Mk.III 1/72

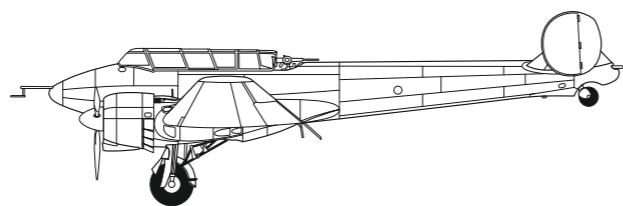

1/72

Bližší informace na internetových stránkách www.cmkkits.com
Further information at internet pages www.cmkkits.com

Special
HOBBY
1/72

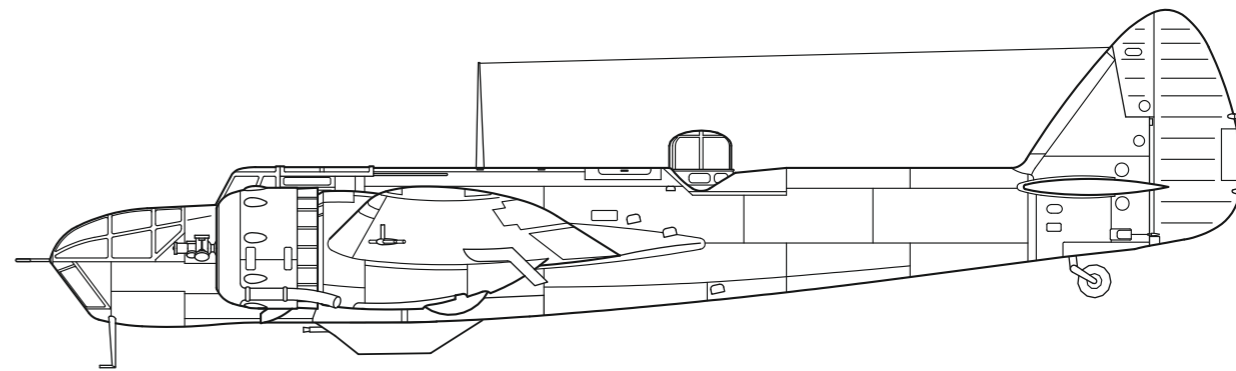

Bristol Blenheim Mk. IVF

CZ RAF začalo zařazovat od počátku roku 1937 do své výzbroje nové bombardéry Blenheim Mk.I. Ty vyráběla firma Bristol pod továrním označením Type 142M. Tyto stroje, odvozené od dopravního Bristolu 142, měly ale díky krátké přídí pouze omezený prostor pro práci navigátora. Proto byl požadován, zejména pro proti-lodní a průzkumné lety, nový letoun. Bristol sice již připravoval nový Type 152, pozdější Beaufort, ale nabídl i prozatímní řešení v podobě stroje Type 149. Šlo o Blenheim s prodlouženou a asymetrickou přídí, zvětšenými nádržemi paliva a úpravami výzbroje. Do služby byly tyto letouny zařazeny pod označením Blenheim Mk.IV a začaly postupně u bombardovacích útvarů nahrazovat starší Blenheimy Mk.I. V prvním období druhé světové války šlo o nejrozšířenější britský taktický bombardér. Sloužil jak v Evropě, tak v Africe, na Středním i Dálném východě. Do výzbroje stíhacích jednotek byla zařazena varianta Mk.IVF vybavená pod trupem zavěšeným kontejnerem se čtyřmi kulomety ráže 7,7 mm. Proti jednomotorovým stíhačkám však tyto stroje neměly šanci. Část z nich byla proto přesunuta k nočnímu stíhání. Některé dostaly pro tuto činnost i radiolokátor. Staly se tak prvními stroji RAF s tímto zařízením.

Rozpětí: 17,17 m, délka: 13,03 m, max. rychlost: 428 km/h v 3 597 m, výstup do 4 575 m: 17 min.,
dostup: 6 706 m, max. dolet: 2 344 km.

GB Blenheim Mk.I bombers were assigned to the RAF's combat units since the beginning of 1937. These aircraft were produced by Bristol by the company's designation Type 142M. Thanks to the short nose section these aircraft, which were derived from the transport Bristol 142, featured only limited space for navigator. Therefore RAF requested new aircraft intended mainly for anti-shiping and reconnaissance role. Even though Bristol prepared new Type 152, later designated Beaufort, Bristol offered as interim solution Type 149. This was Blenheim that featured lengthened and asymmetrical nose section, enlarged fuel tanks and modified armament. RAF designated these aircraft Blenheim Mk.IV and assigned them to the combat unit where they gradually replaced the older Blenheim Mk.Is. It was widely used British tactical bombers in the first part of the WW 2. It was used in Europe, Africa, Middle and Far East. Blenheim Mk.IVF version that was equipped with belly mounted pod with four 7.7 mm machineguns was assigned to the fighter units. Anyway, these aircraft were useless against enemy single engined fighters. Therefore part of them was transferred to the night fighter units. Some aircraft were even equipped with radar and became the first RAF machines carrying this device.

Span 17.17 m, Length 13.03 m, Maximum speed 428 km/h at 3597 m, Climb to 4575 m: 17 min,
Service ceiling 6706 m, Range 2344 km.

CAM.C

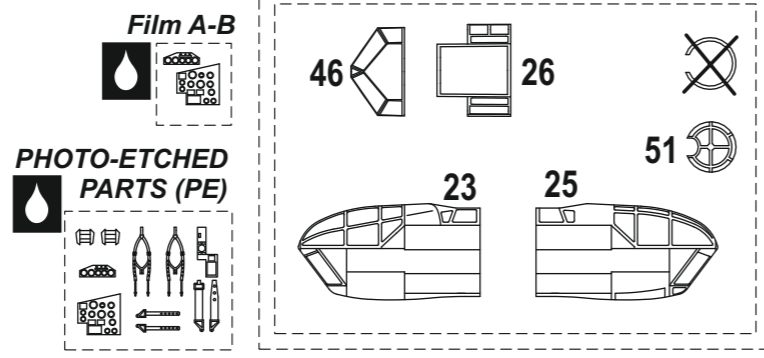
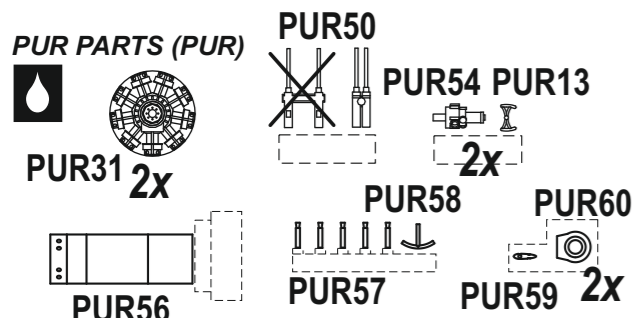
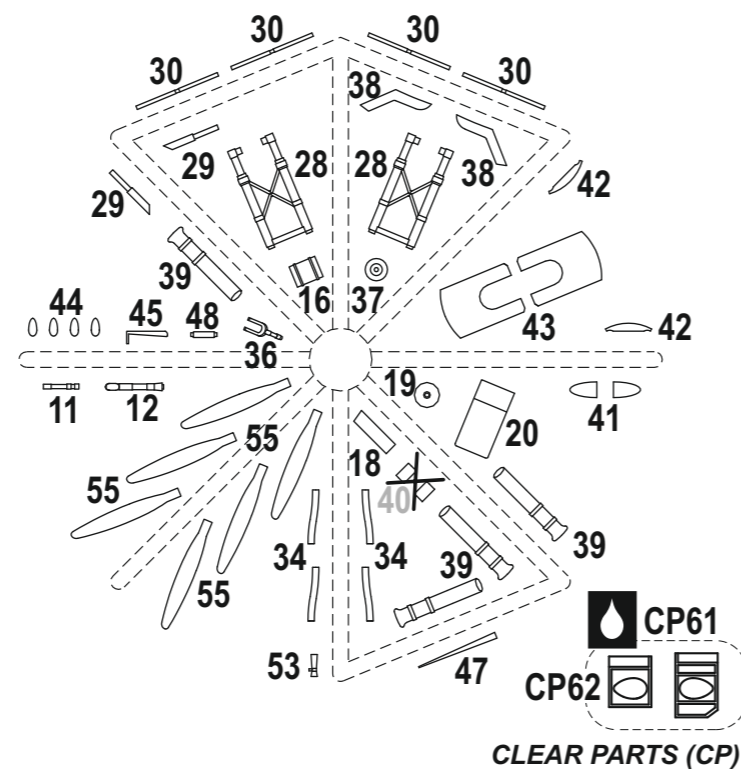
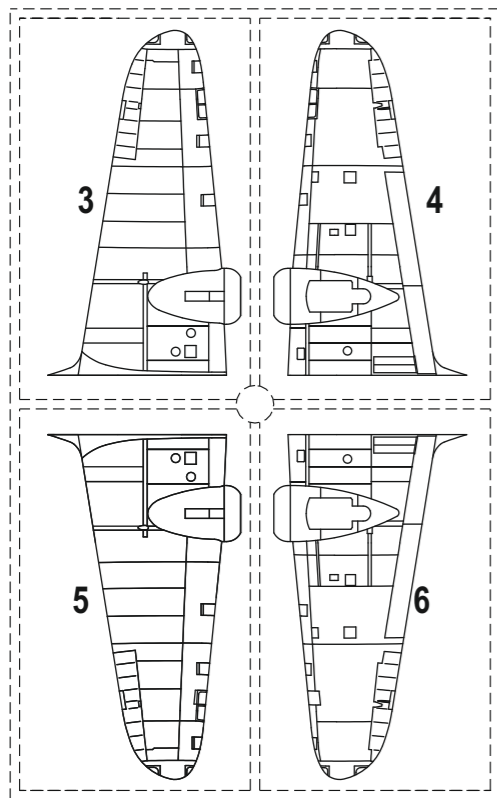
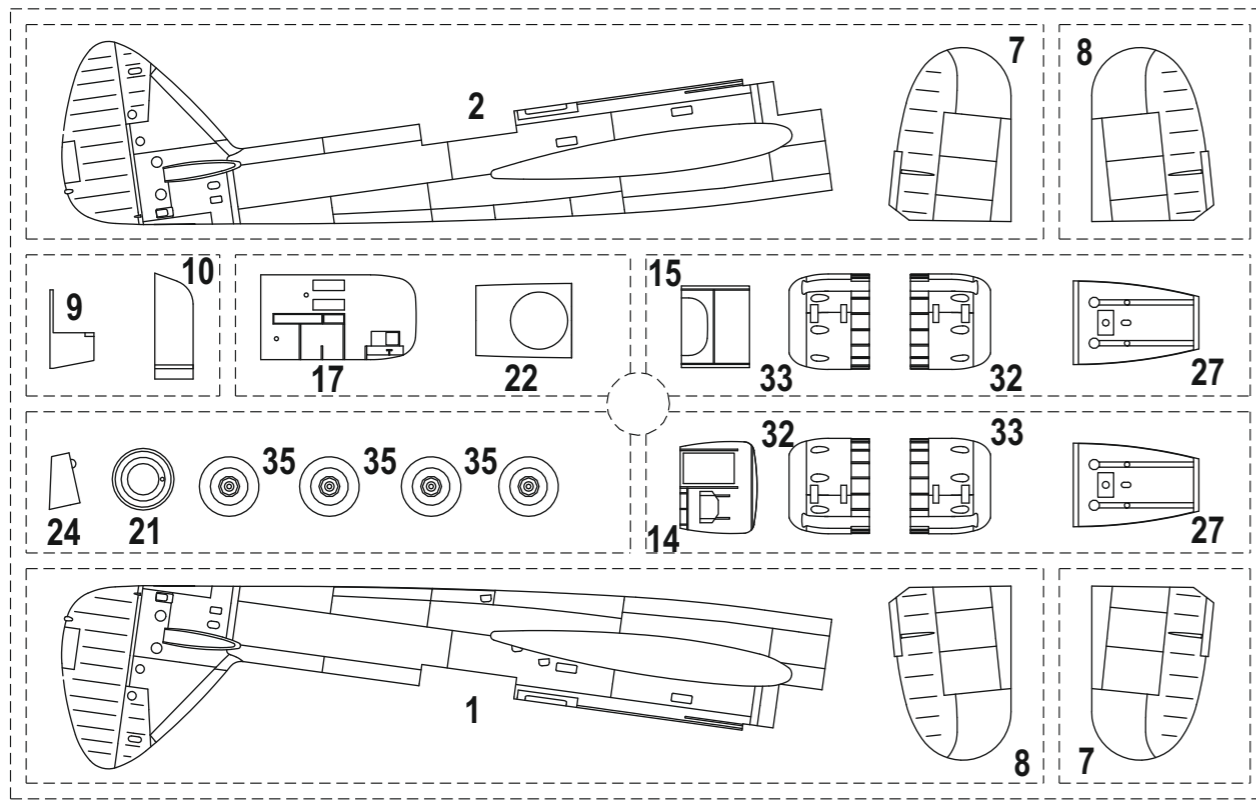

MOŽNOST VOLBY OPTIONAL NACH BELIEBEN OPTION
 LEPIDLO NA KOV GLUE FOR METAL METALLKLEBER COLLE A METAL
 ZHOTOVIT NOVÉ SCRATCH BUILD FERTIGSTELLEN ACHEVER
 OHNOUT BEND BIEGEN COURBER
 GSI colours code
 NATŘÍT COLOUR FARBEN PEINDRE
 ODDĚLIT CUT WITH KNIFE MIT MESSER SCHNEIDEN COUPER AU COUTEAU

2008/02

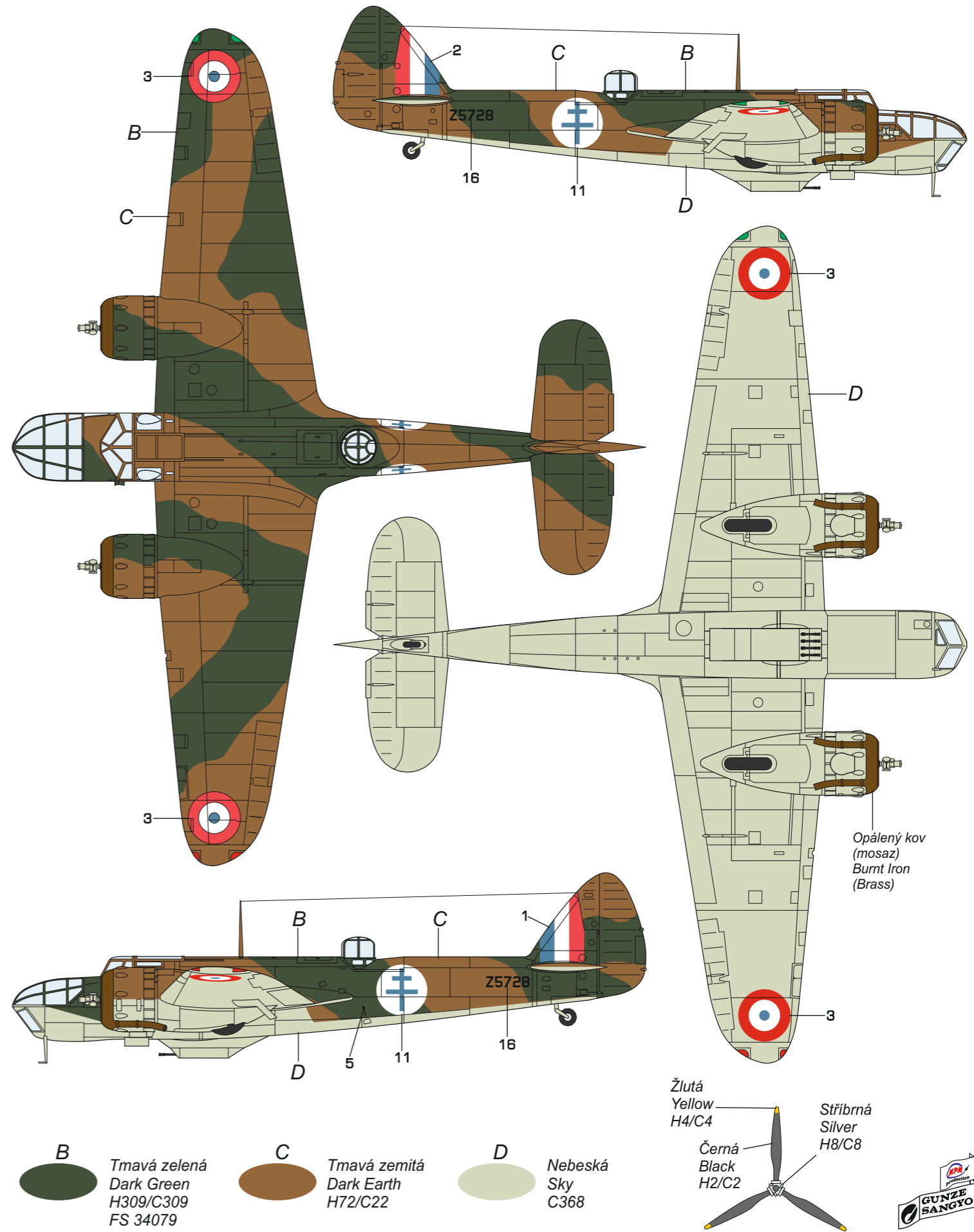

Opálený kov (mosaz) Burnt Iron (Brass)

Žlutá Yellow H4/C4
 Černá Black H2/C2
 Stříbrná Silver H8/C8

B Tmavá zelená Dark Green H309/C309 FS 34079
 C Tmavá zemitá Dark Earth H72/C22
 D Nebeská Sky C368



2008/02

Blenheim Mk.IVF V5735/QY-D, 254. Sqn. RAF Coastal Command, Aldegrove, červenec 1941. Letoun měl až na kov odřené klapky motorových krytů a na horní ploše křídla vně motorových gondol stopy po opravách.

Blenheim Mk.IVF V5735/QY-D, RAF 254th Squadron, Coastal Command, Aldegrove, July 1941. The cowling flaps were weathered to the bare metal and camouflage repairs are evident outside both engine nacelles.

CAM. B

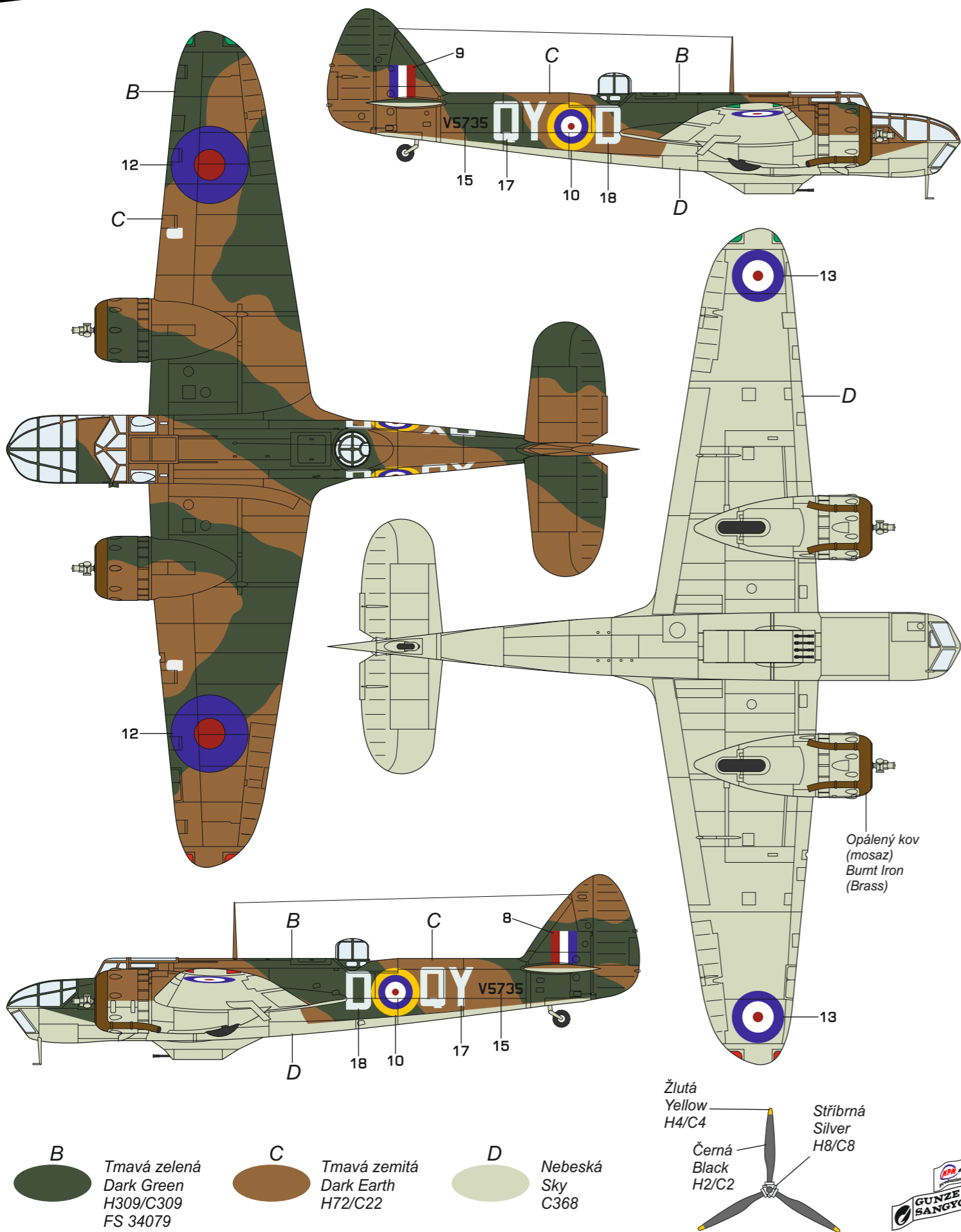

Opálený kov (mosaz)
Burnt Iron (Brass)



2008/02

SH72063 Bristol Blenheim Mk. IVF ⑧

1

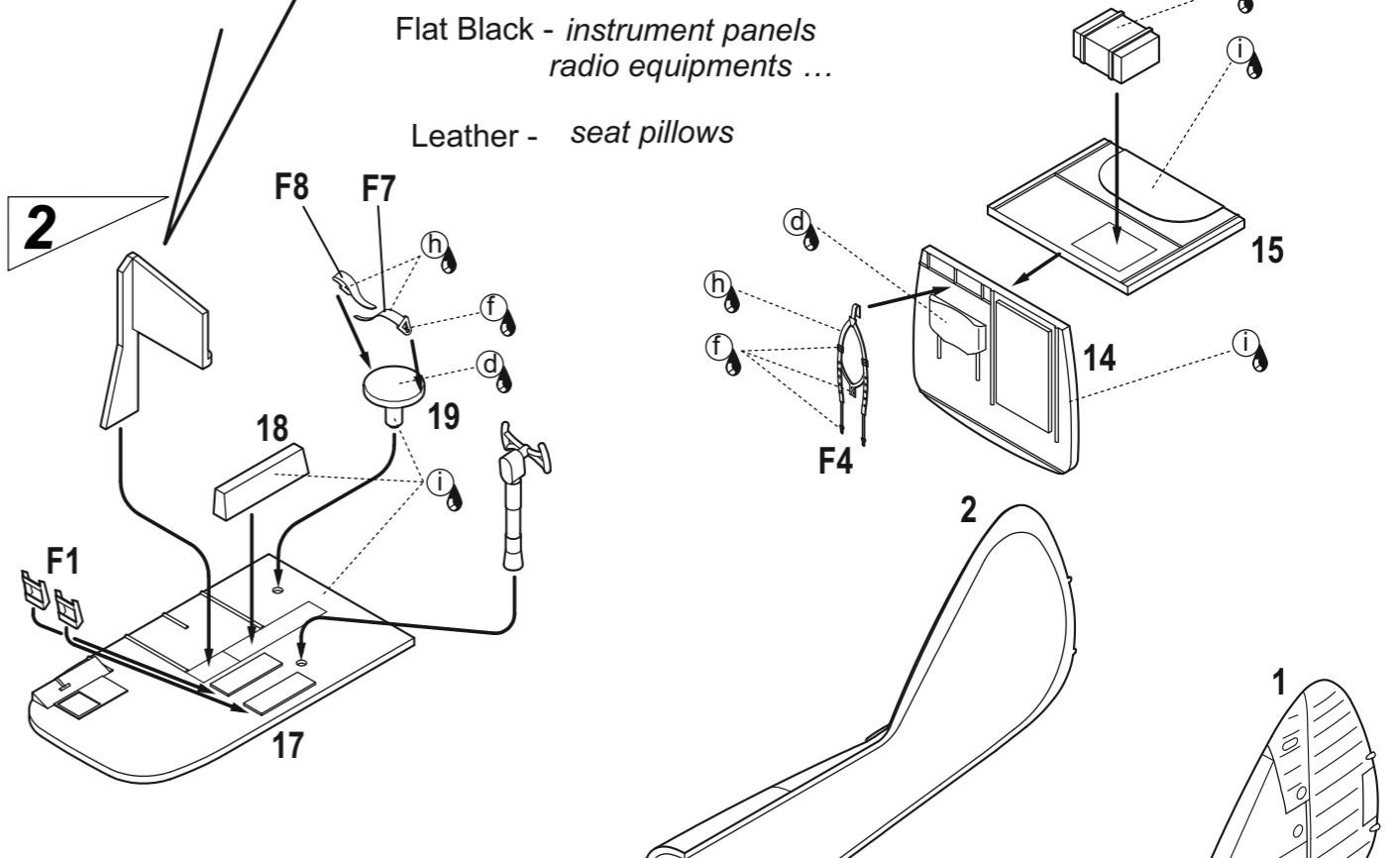
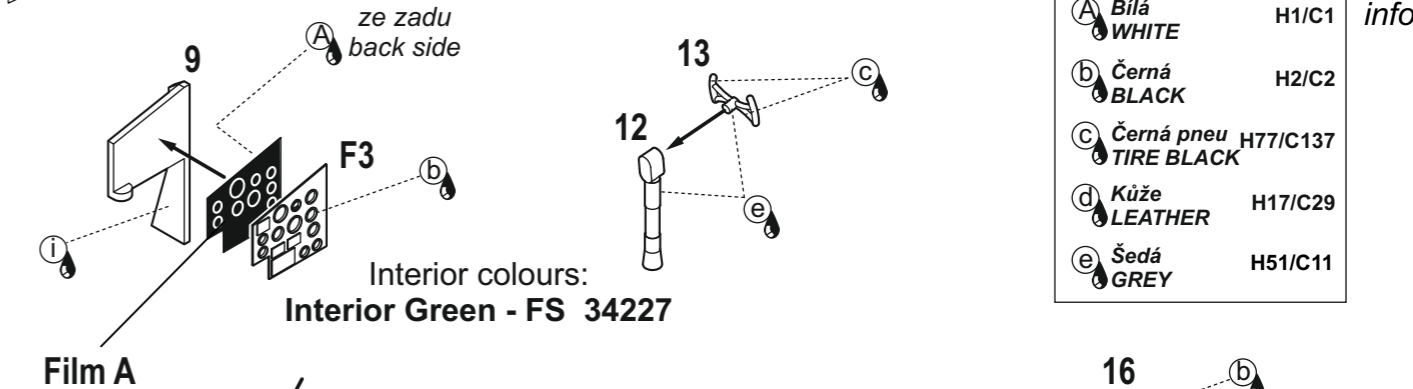

3

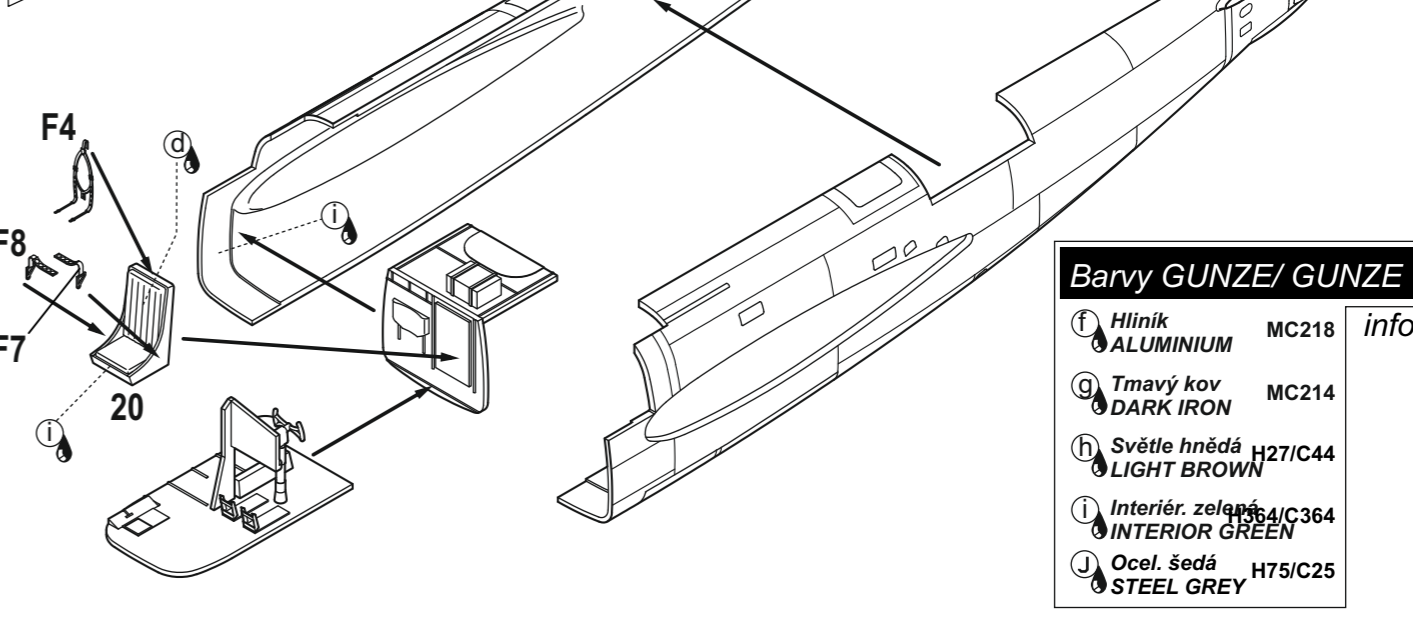

2008/02

SH72063 Bristol Blenheim Mk. IVF ③

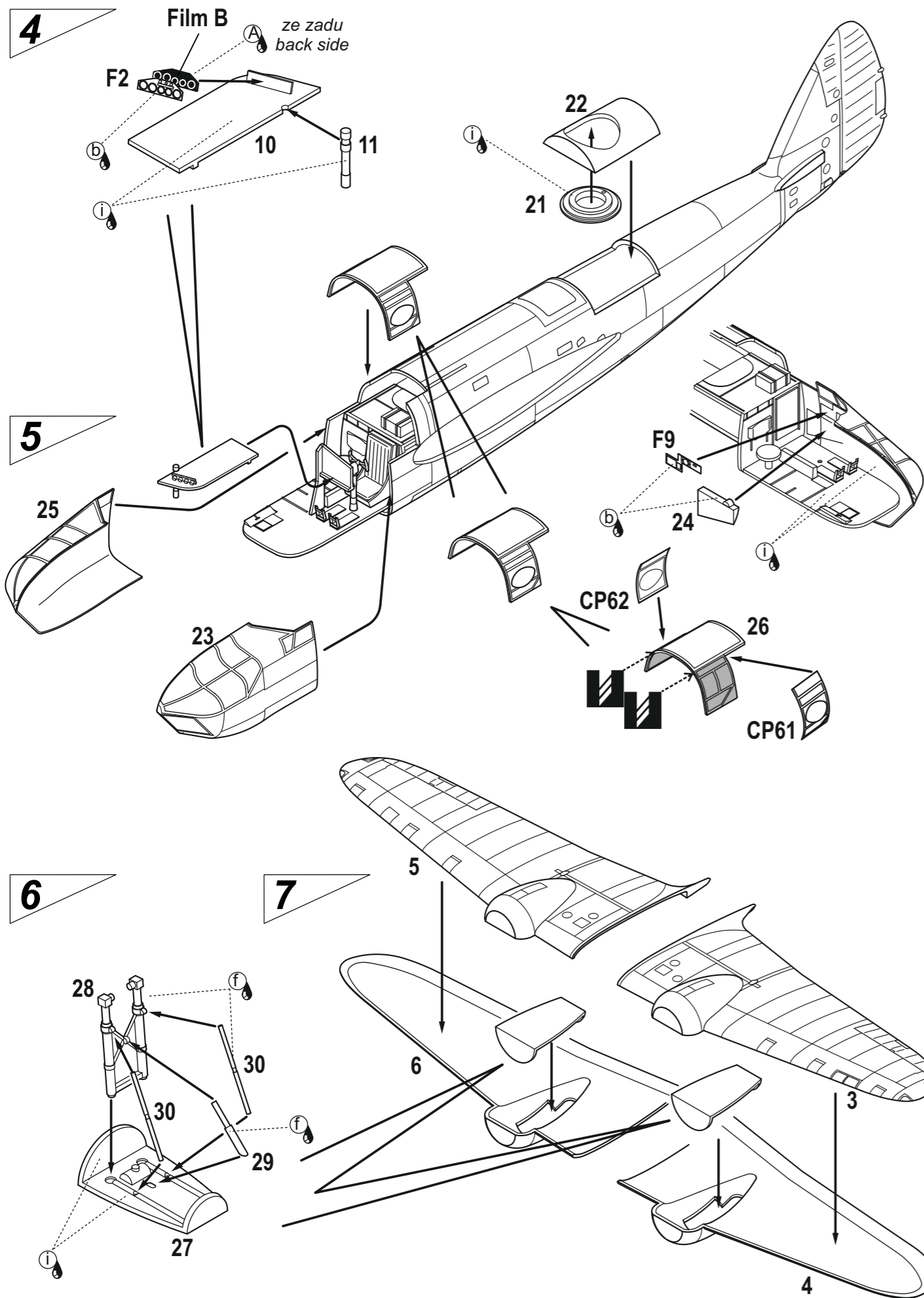

Blenheim Mk.IVF Z5722/WM-Z, 68. Sqn. RAF, letiště Catterick, 1941. Letoun byl vybaven radarem.

CAM. A

Blenheim Mk.IVF Z5722/WM-Z, RAF 68th Squadron, Catterick airbase, 1941. The aircraft was equipped with radar.

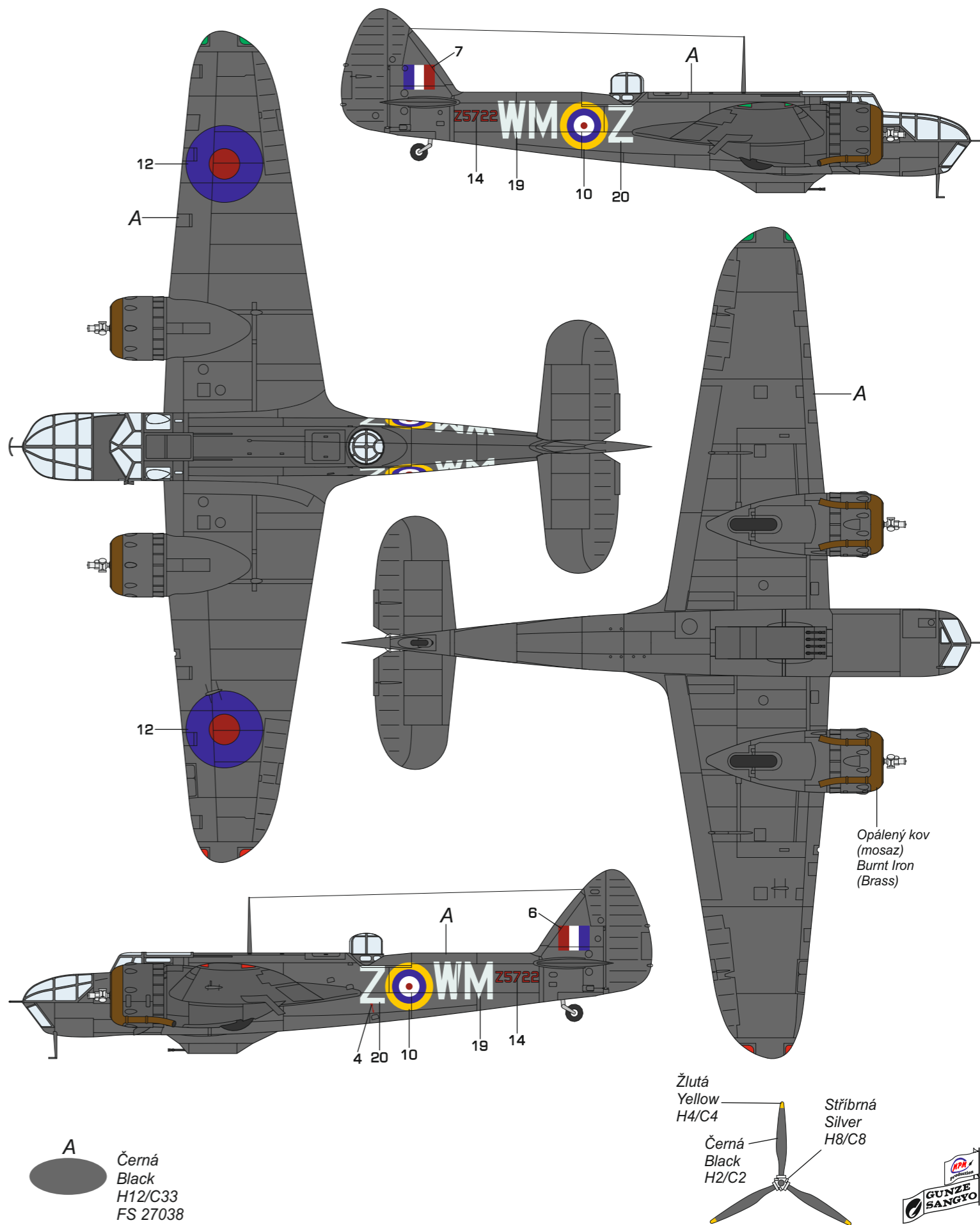

A
Černá
Black
H12/C33
FS 27038

Žlutá
Yellow
H4/C4
Černá
Black
H2/C2
Stříbná
Silver
H8/C8



10

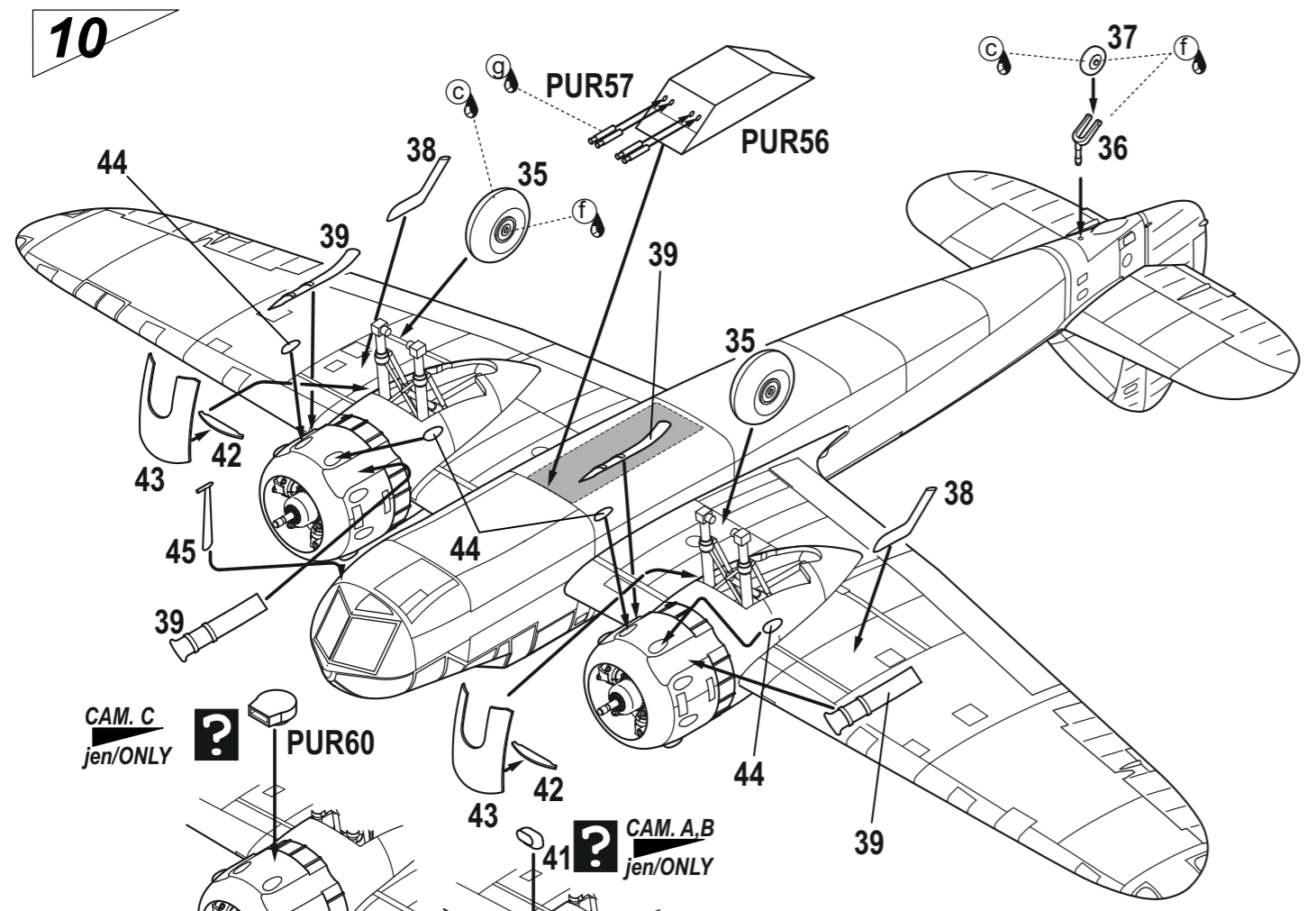

11

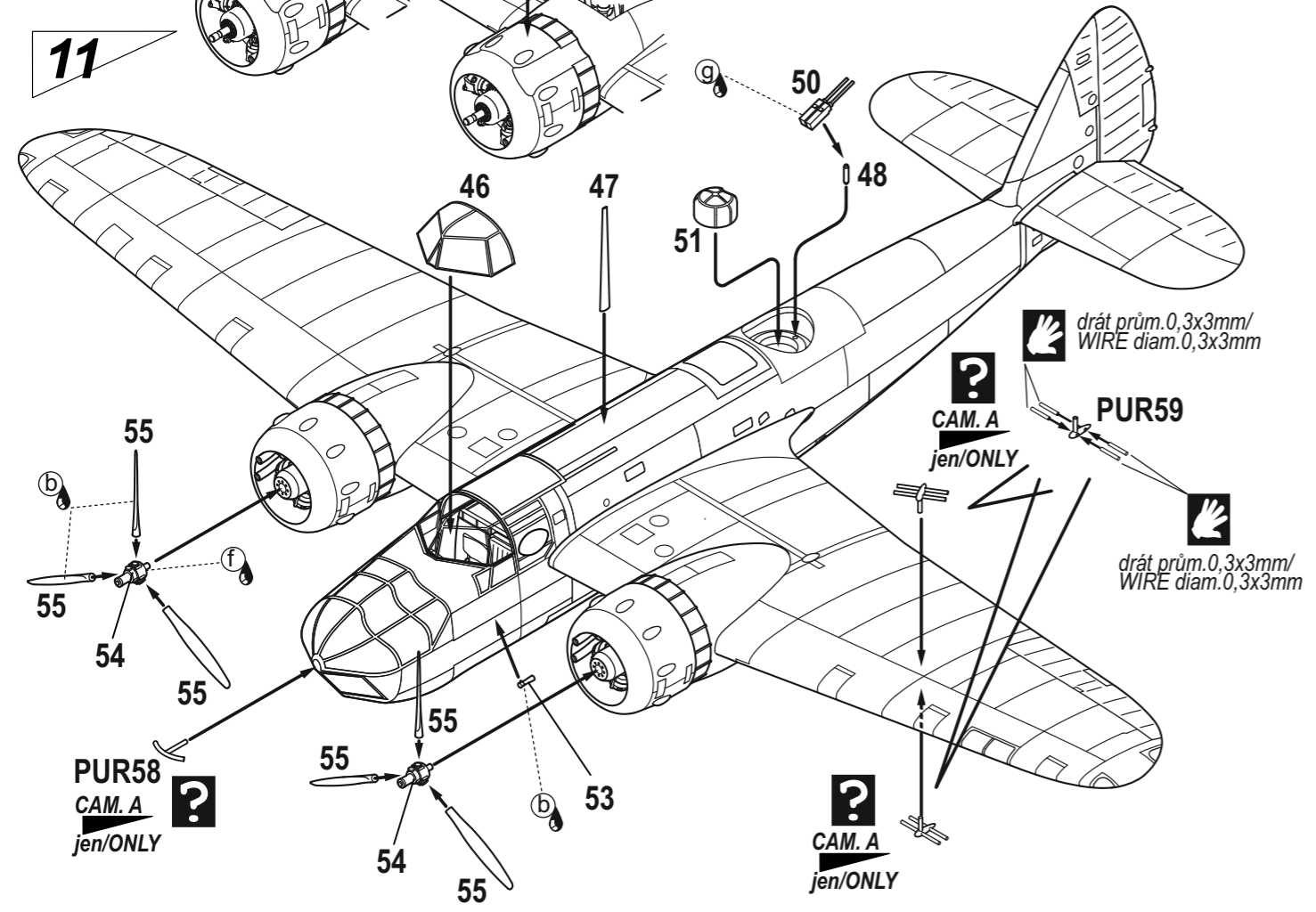

8

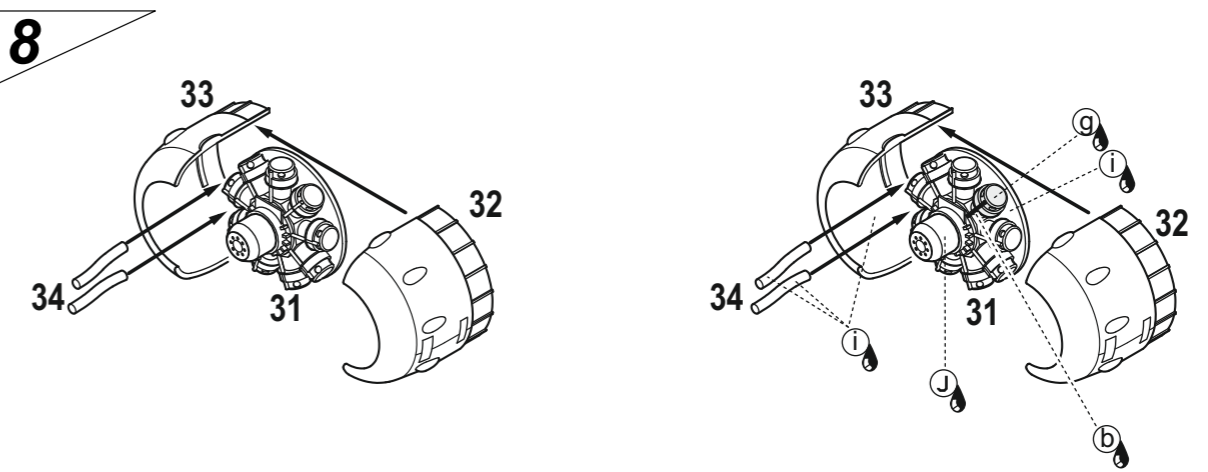

9

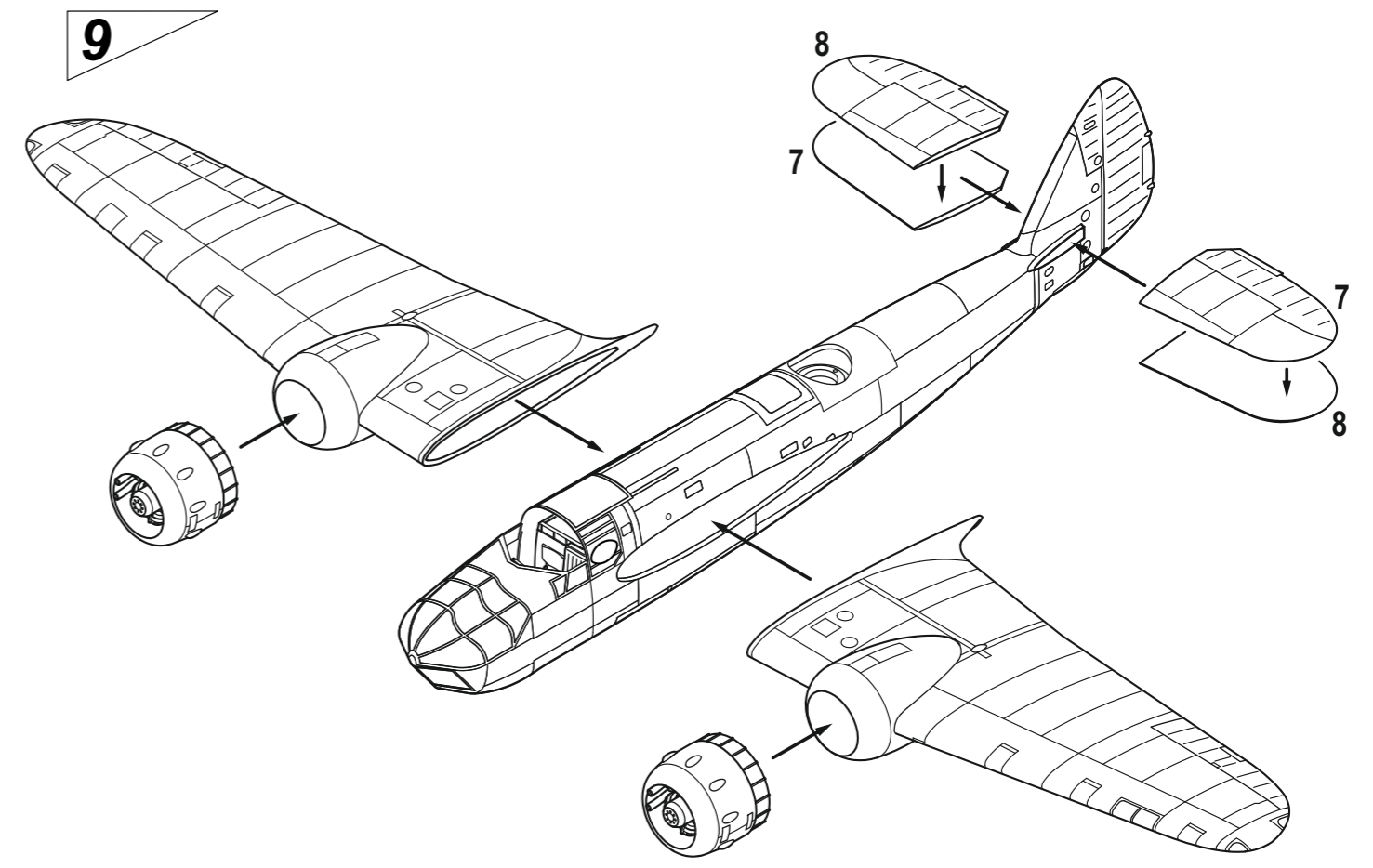

INFOview

