

F-84F Thunderstreak

In 1948, a swept wing version of the F-84 was created with the hope of bringing performance to the level of the F-86. The last production F-84E was fitted with a swept tail, a new wing with 38.5 degrees of leading edge sweep and 3.5 degrees of anhedral, and a J35-A-25 engine producing 5,300 pound-force (23.58 kN) of thrust. The aircraft was designated XF-96A. It flew on 3 June 1950 with Otto P. Haas at the controls. Although the airplane was capable of 602 knots (693 mph, 1,115 km/h), the performance gain over the F-84E was considered minor. Nonetheless, it was ordered into production in July 1950 as the F-84F Thunderstreak. The F-84 designation was retained because the fighter was expected to be a low-cost improvement of the straight-wing Thunderjet with over 55 percent commonality in tooling.

In 1957 the first operational Wing was formed, being JagdBomberGeschwader 31 (JBG31) at Büchel, later Nörvenich with squadron-code DA, followed by 5 more during the period 1958 to 1961, these being JBG32 (Lechfeld, code DB), 33 (Büchel, code DC), 34 (Memmingen, code DD), 35 (Husum, code DE) and 36 (Rheine-Hopsten, code DF). The last Thunderstreaks went out of service in December 1966, although already from 1961 the F-104 Starfighter gradually took over its role. More than 230 German Streaks were transferred to the Turkish and Greek Air Forces and some still survive today as monuments or in museums.

CAUTION

- *Read carefully and fully understand the instructions before commencing assembly.
- *Keep out of reach of children. Children must not be allowed to put any parts in their mouths, or pull plastic bag over their heads.
- *When using adhesives and paints, please make sure not to use them in closed room or near the fire.
- *When assembling this kit, tools including knives are used. Extra care should be taken to avoid injury.

WARNING: CONTAIN SMALL PARTS NOT FOR CHILDREN UNDER 14 YEARS OF AGE



Drill



Remove



2 Set



Bend



Optional



Decal



Super Glue



Fill Hole



No Cement



Be Careful

TOOLS RECOMMENDED

Cement

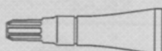

Side Cutter



Modeling Knife

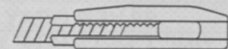

Tweezers

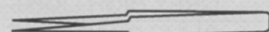

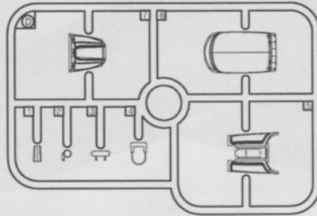
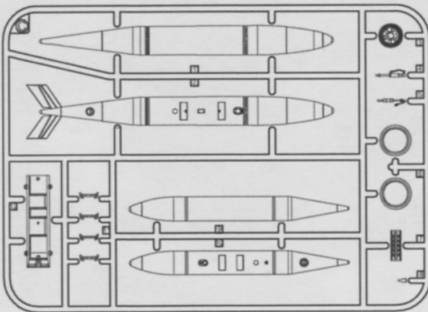
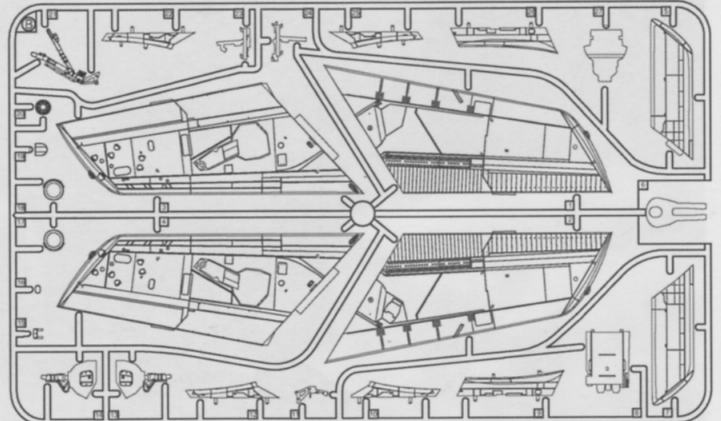
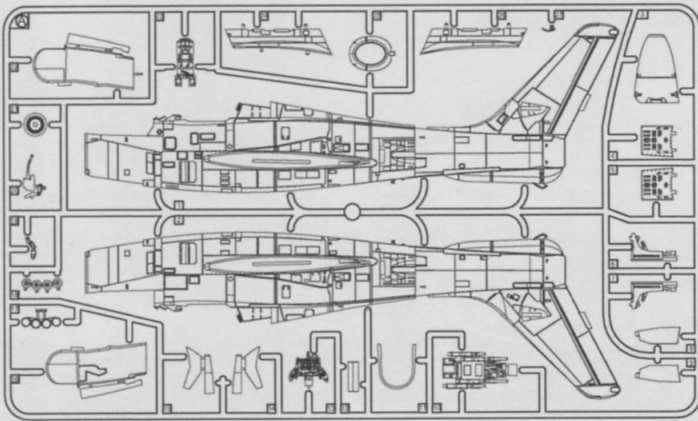

AFTERMARKET SERVICES CARD

When requesting replacement parts, please take or send this form to your local dealer so that the parts required can be correctly identified. Please note that specifications and availability are subject to change without notice. Or visit <http://www.kineticmodel.com> for latest information. For more information, please contact services@kineticmodel.com

Part Code	K48068	Qty	Item
00-098-001	1/48 F-84F FUSELAGE	1	A
00-098-002	1/48 F-84F WINGS	1	B
00-098-003	1/48 F-84F TANKS AND WHEEL	2	C
00-098-004	1/48 F-84F CANOPY CLEAR PARTS	1	D
01-098-48068	1/48 F-84F EUROPE MARKING	1	Decal
03-098-48068	1/48 F-84F EUROPE MANUAL	1	MANUAL



COLOR	AMMO MIG	VALLEJO MODEL COLOR	GSI CREOS MR. COLOR	TAMIYA ENAMEL/ACRYLIC	HUMBROL
SATIN BLACK	A.MIG-032	70.861	2	X-1	85
GUN METAL	A.MIG-045	71.072	-	X-10	53
MATT BLACK	A.MIG-046	71.057	33	XF-1	33
RED	A.MIG-049	70.909	3	XF-7	153
GREY FS36251	A.MIG-059	71.050	-	-	-
NATO GREEN	A.MIG-084	71.093	54	XF-67	-
YELLOW OLIVE	A.MIG-087	70.877	-	-	-
BURNT IRON	A.MIG-187	71.073	61	XF-84	-
SILVER	A.MIG-195	71.063	8	X-11	11
SILVER GRAY	A.MIG-212	71.119	332	-	-
ZINC CHROMATE YELLOW	A.MIG-221	71.107	27	XF-4	81
GREY HIGH LIGHT	A.MIG-910	71.277	25	XF-54	-
OLIVE DRAB BASE	A.MIG-926	71.286	304	-	-
PRU BLUE	-	71.109	-	-	230

For Color Profile, please go to www.kineticmodel.com for download (type the kit# and go for manual/painting guide)

1

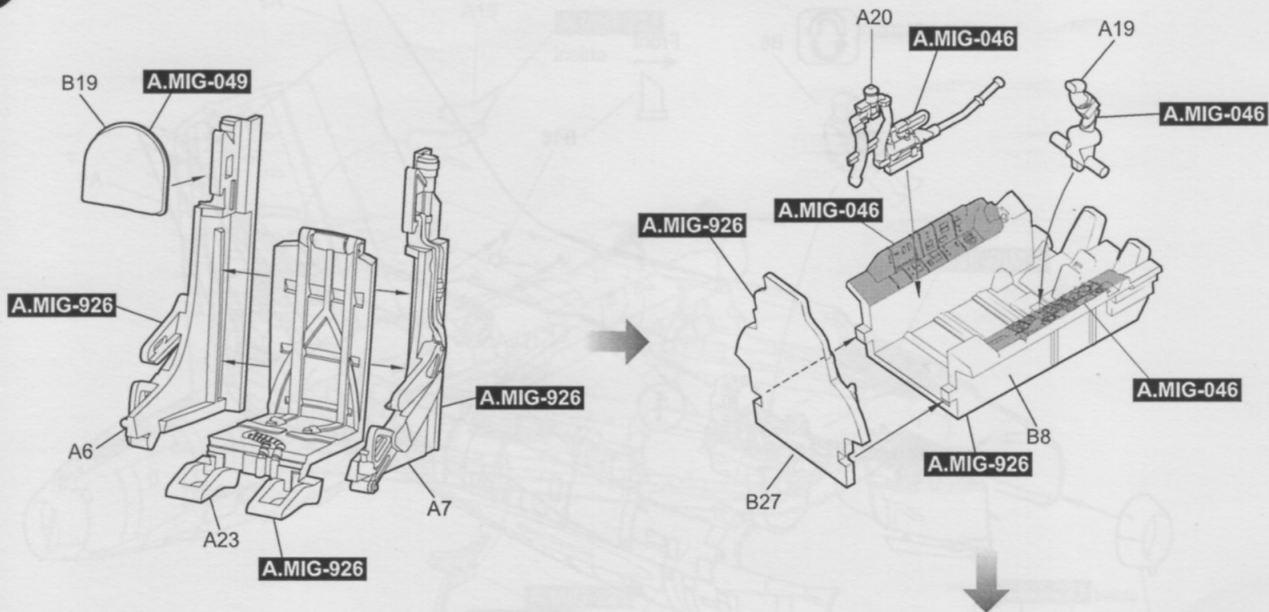

2

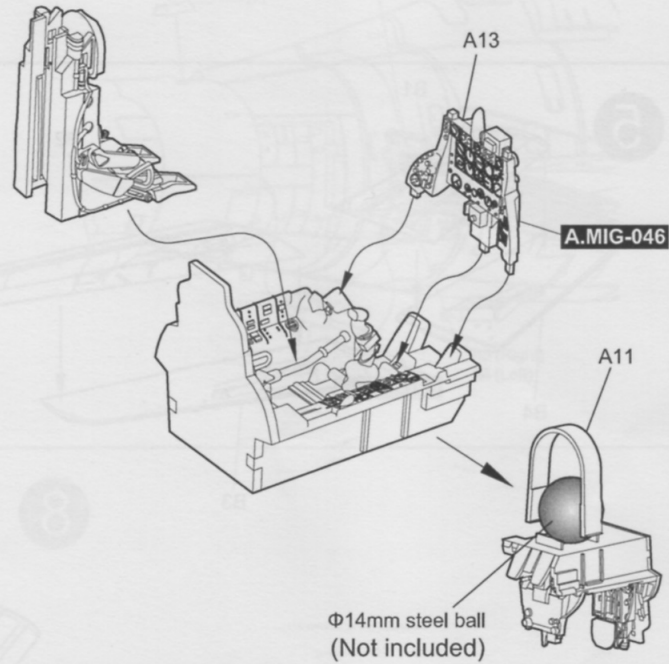
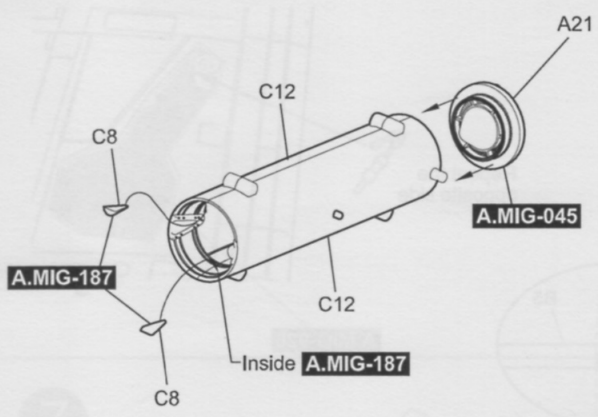

3

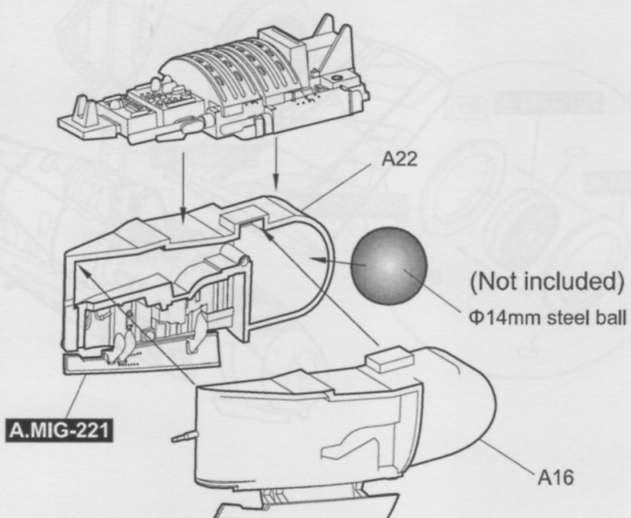
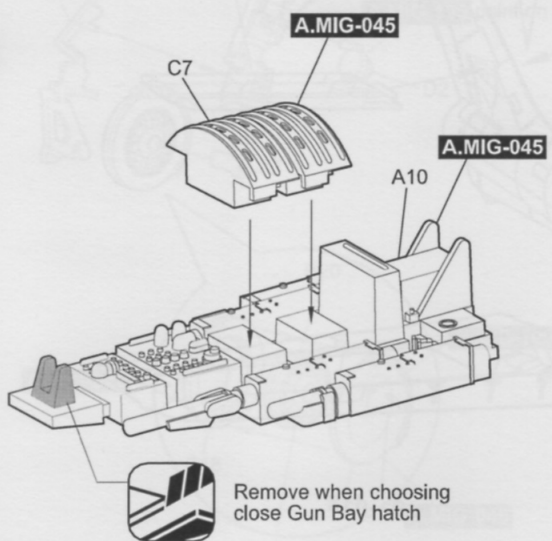

4

CALIF AIRCRAFT SERIES NO. 20063

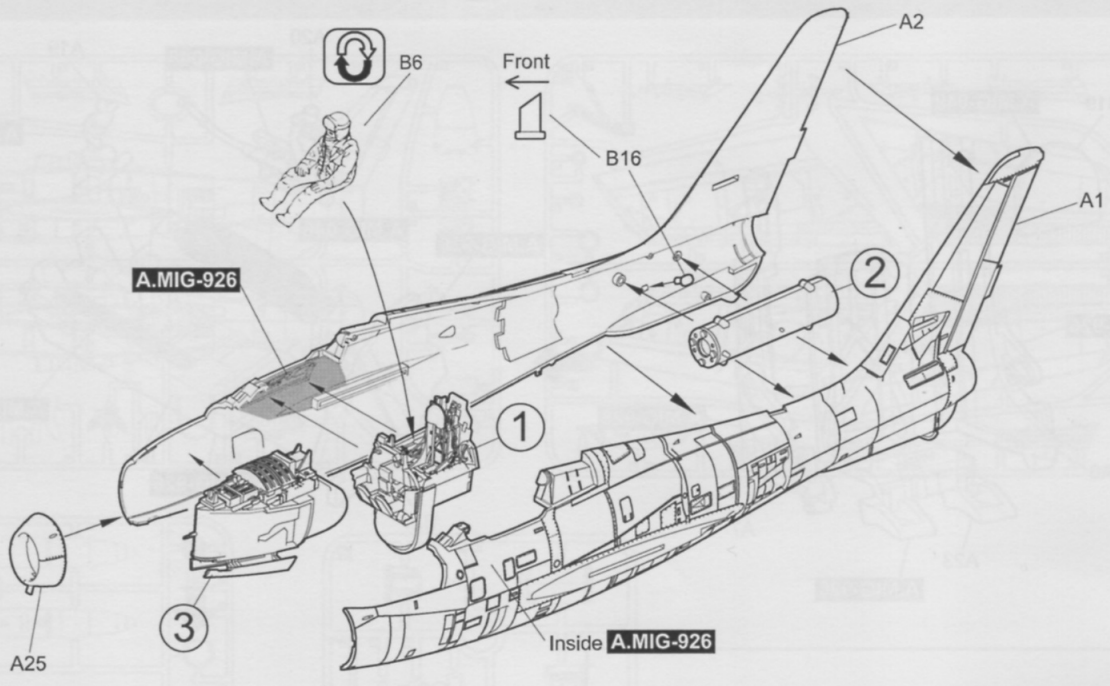

5

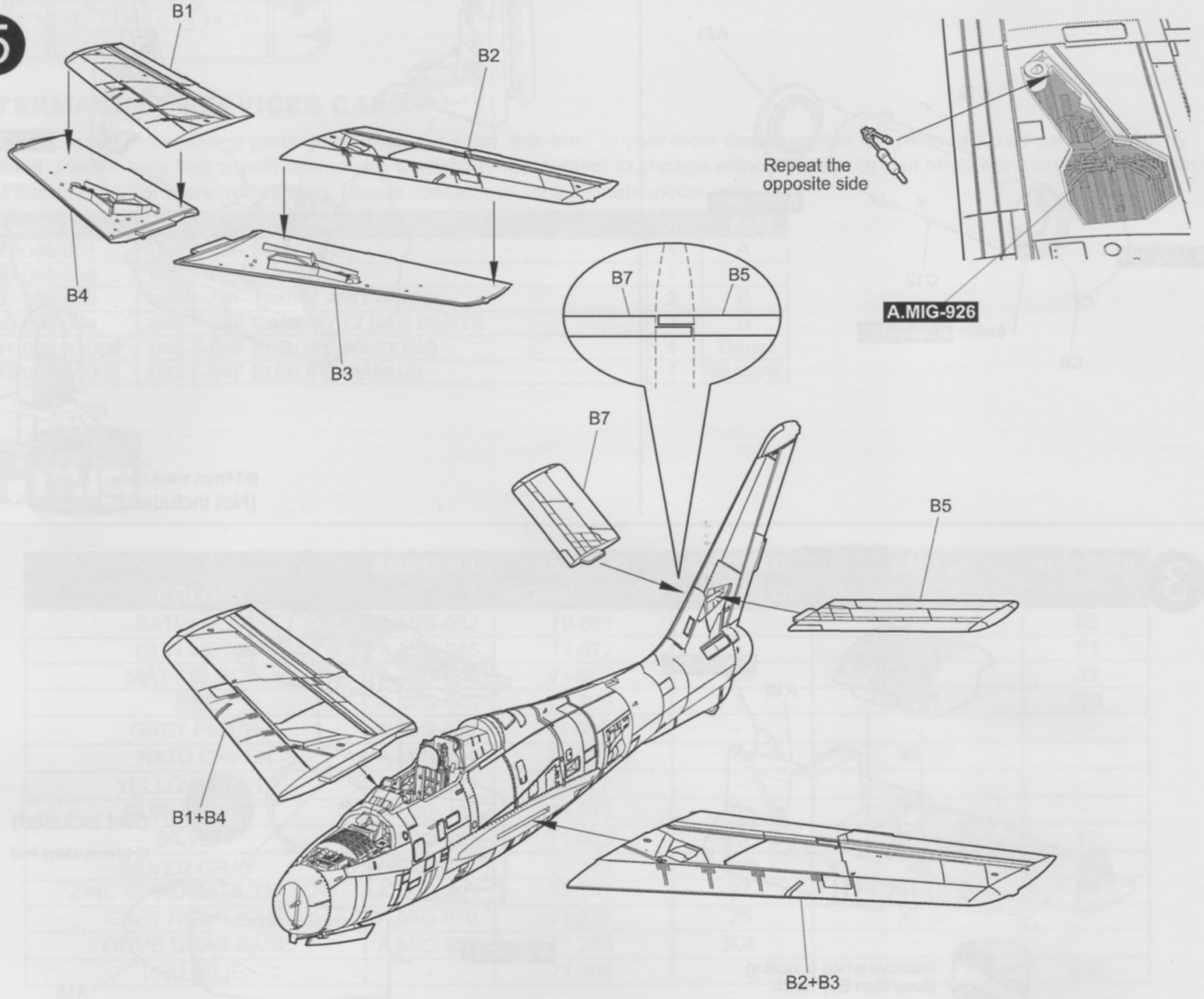

For Color Profile, please go to www.tamiya.com for download type the kit and go for manual painting gallery

6

9

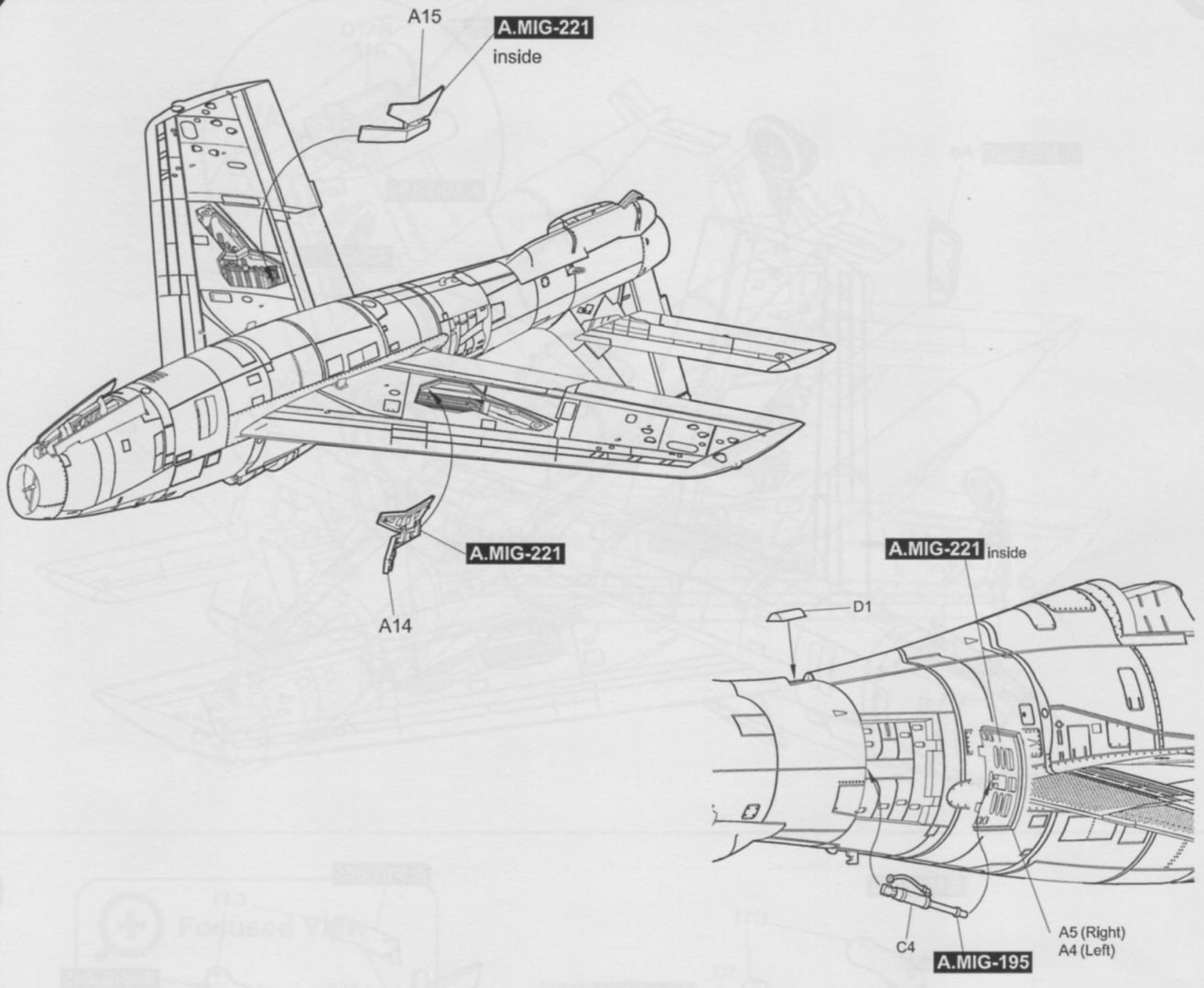

7

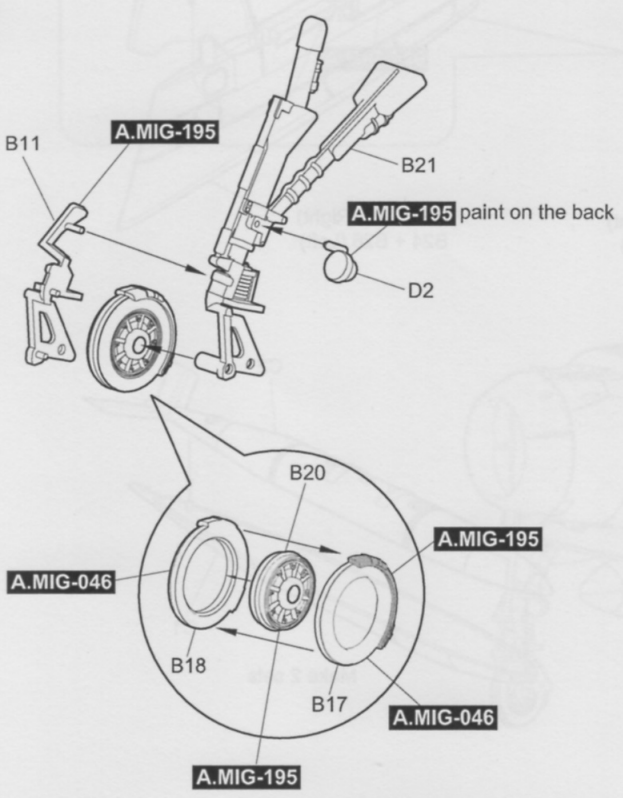

8

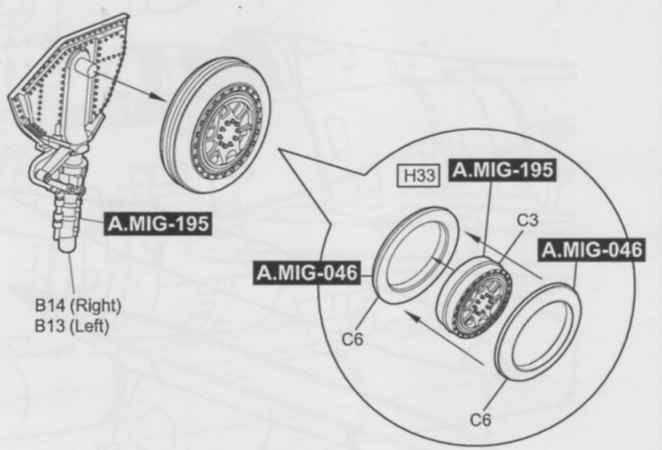

A.MIG-926 A8

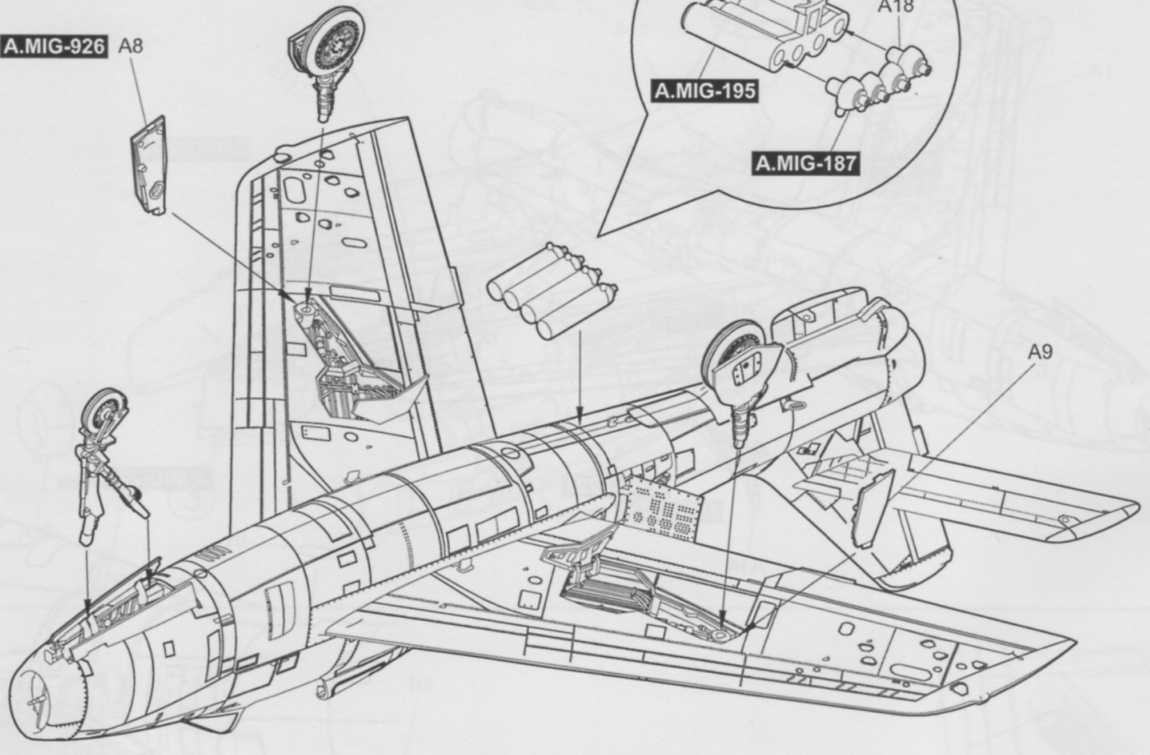
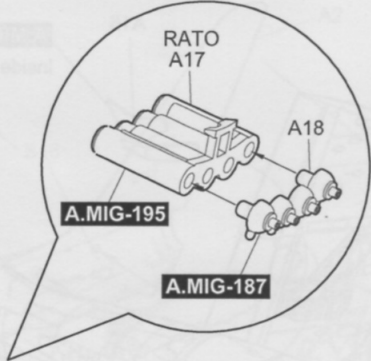

A.MIG-045

C11

A.MIG-045

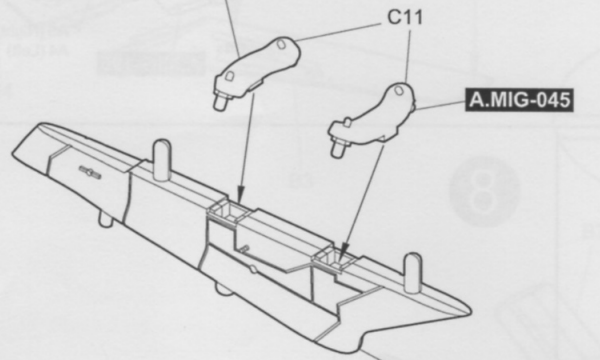

A.MIG-045

C11

A.MIG-045

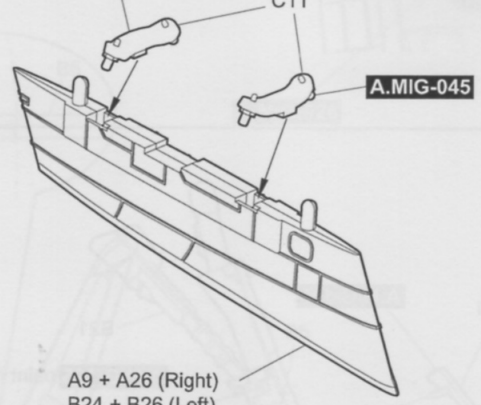

C10

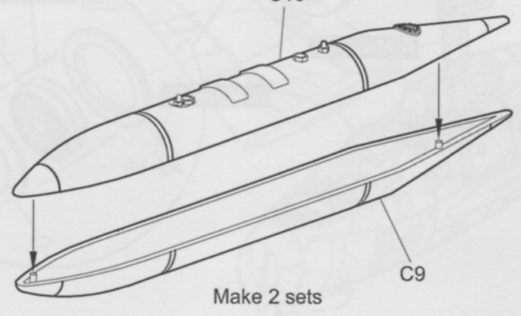

C2

C1

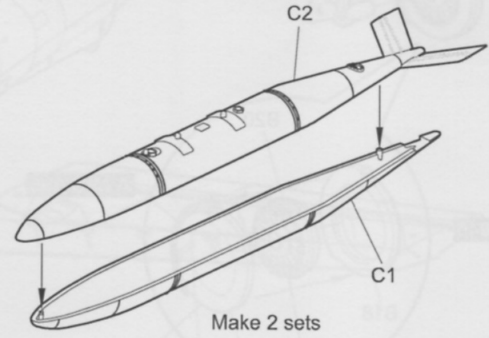

10

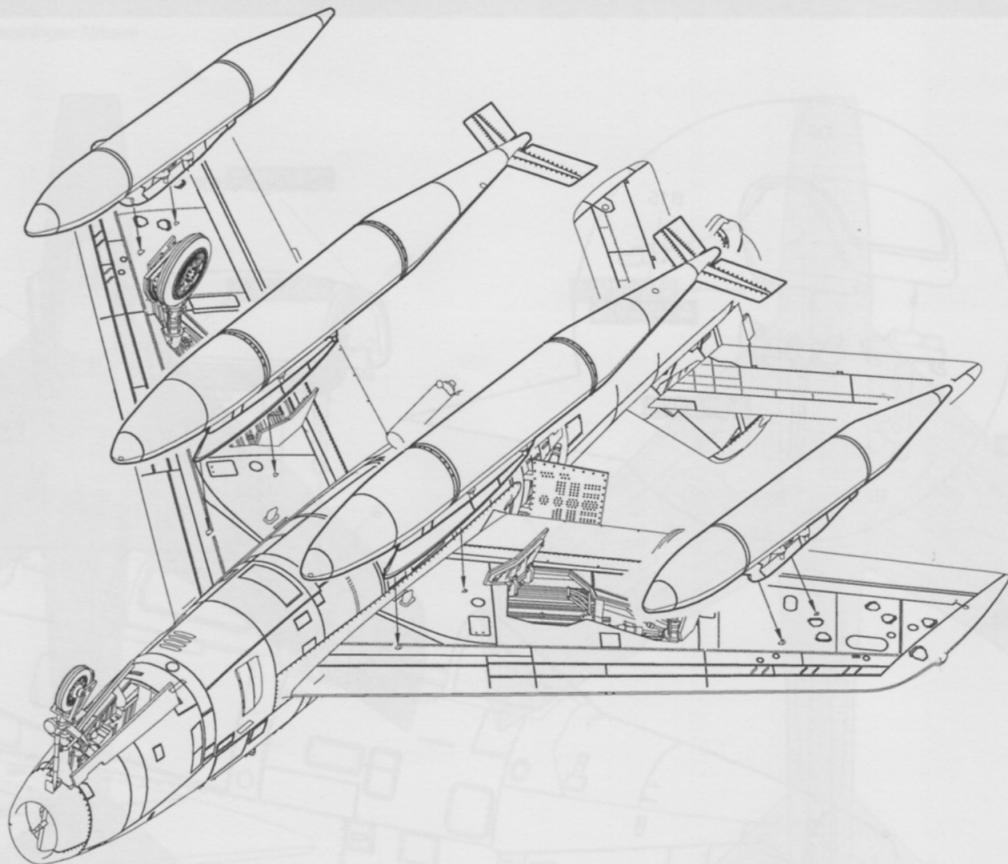

11

+ Focused View

A magnified view of two parts: D7, a curved fuselage section, and A27, a small rectangular component. A callout box labeled **A.MIG-046** points to part A27, indicating its specific application.

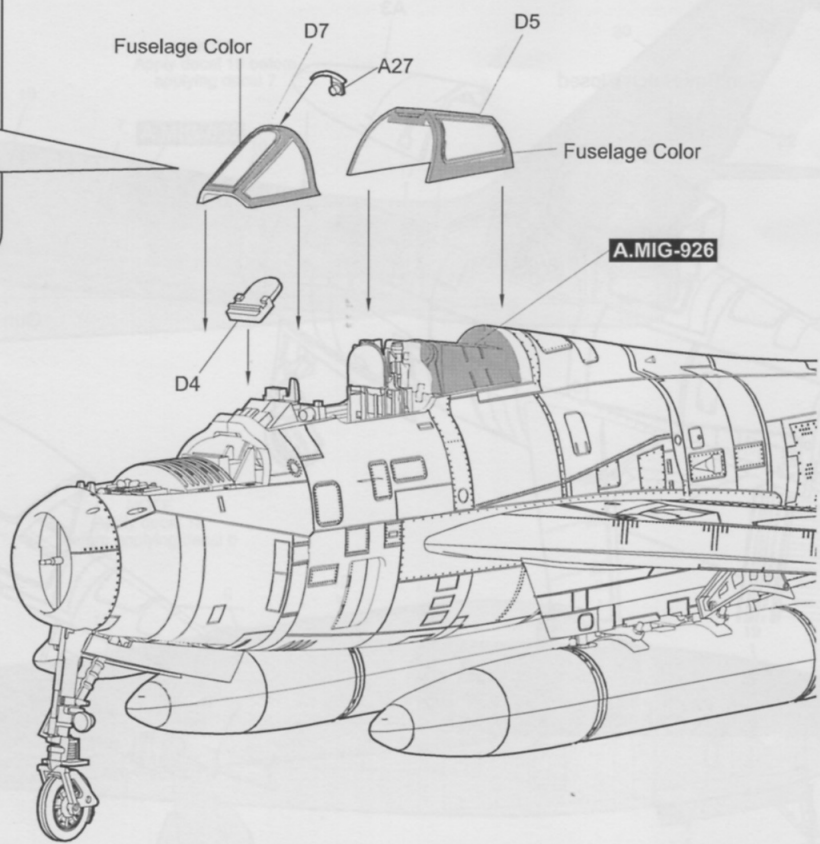

12

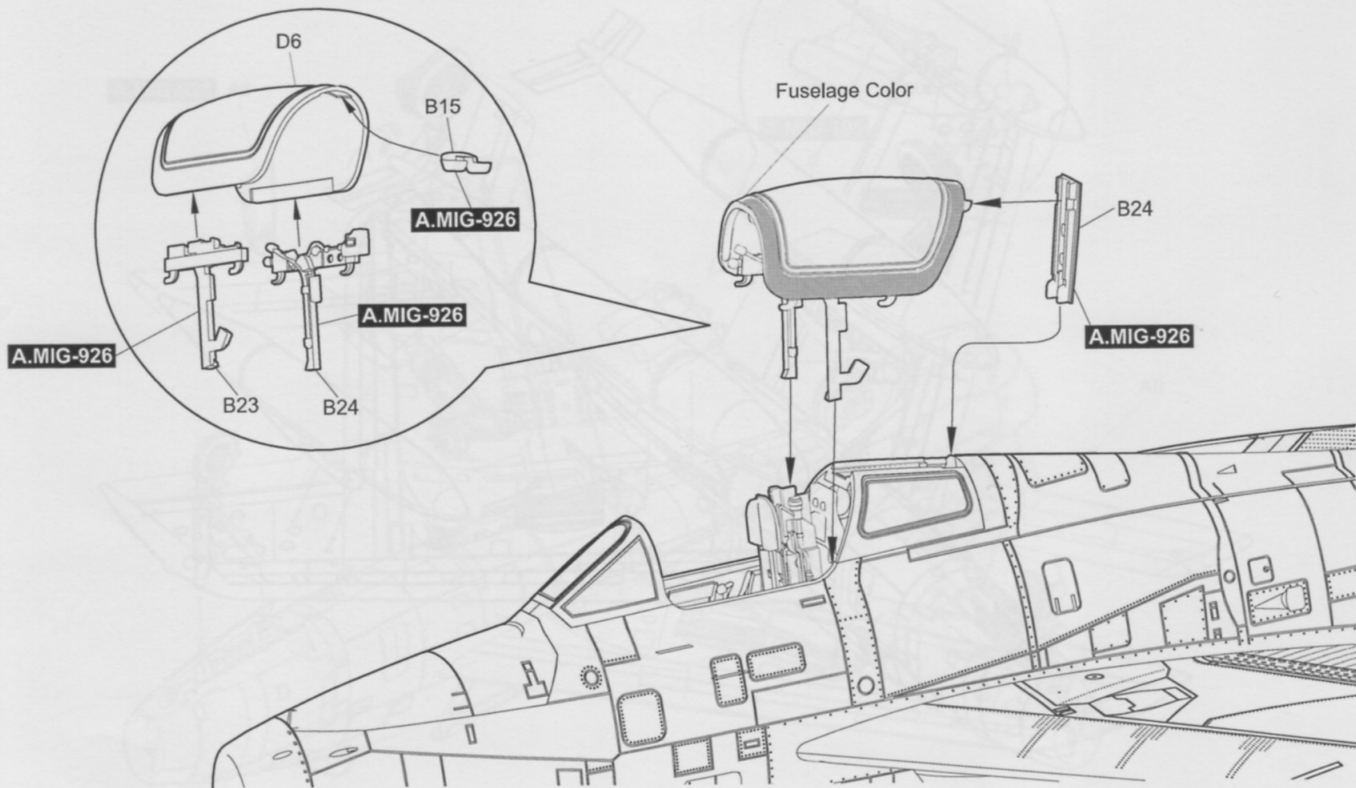

13

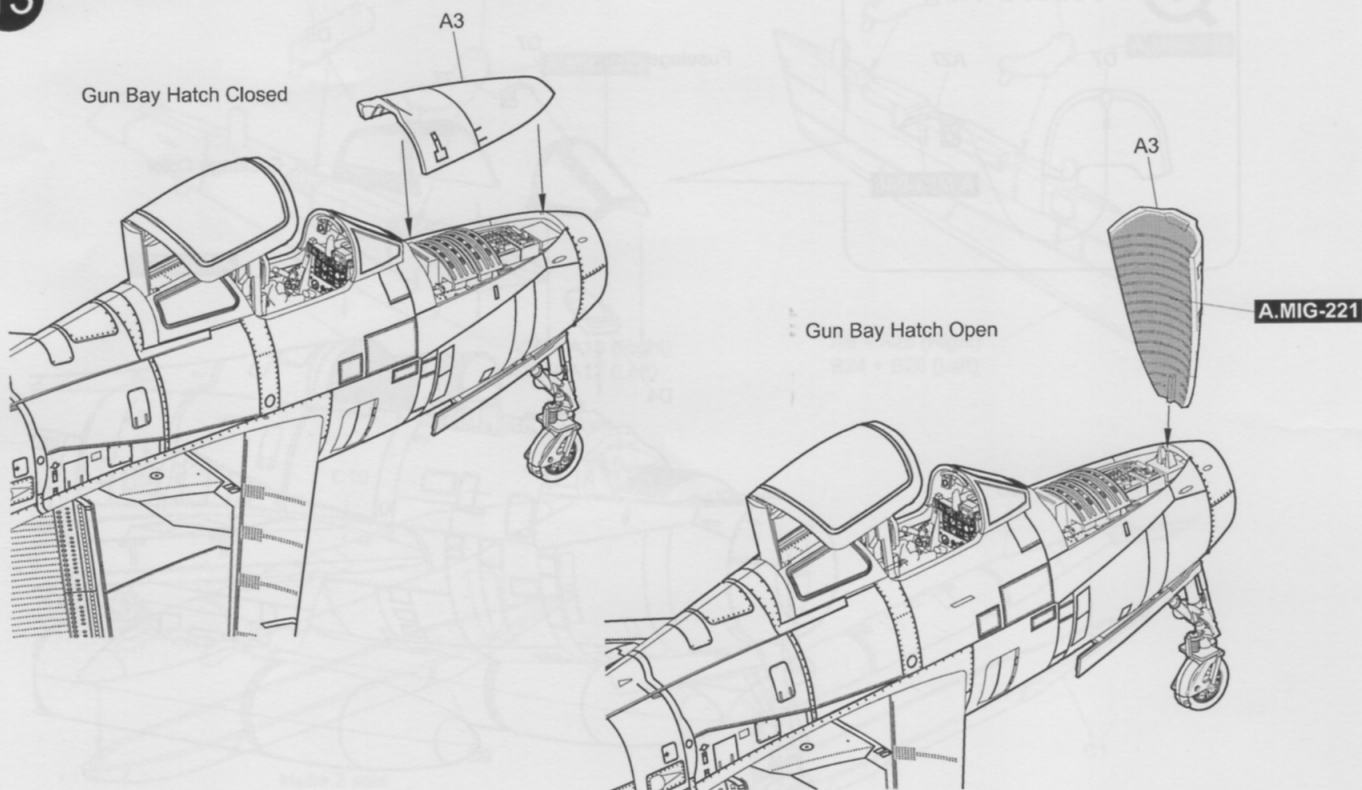

1/48 SCALE AIRCRAFT SERIES NO.K48068



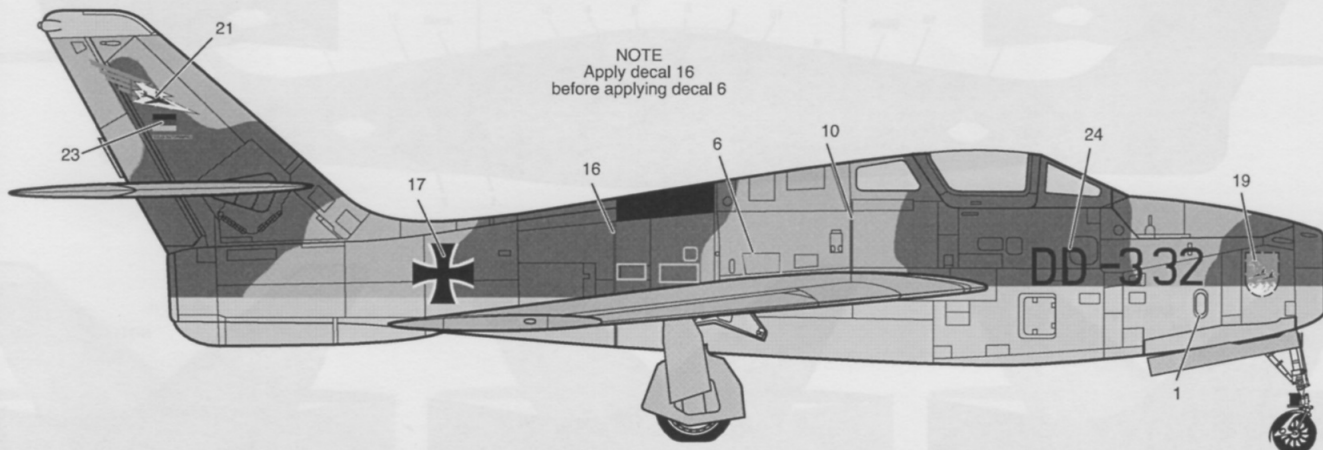
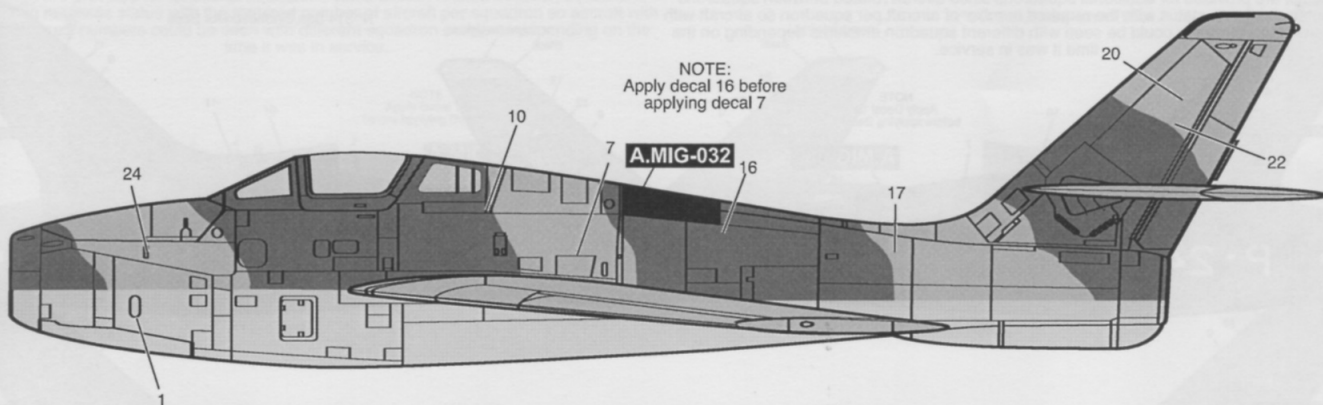
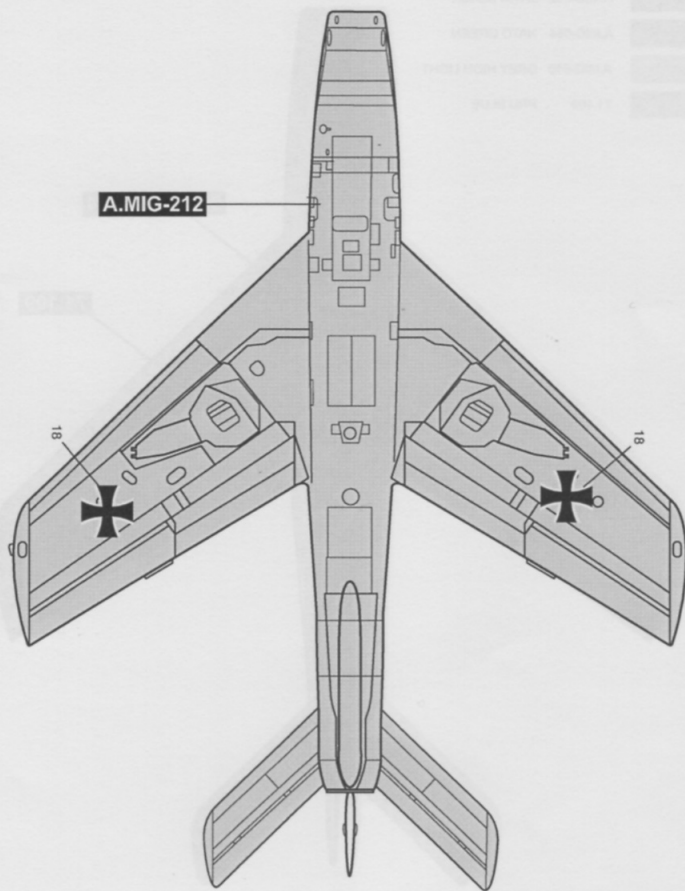
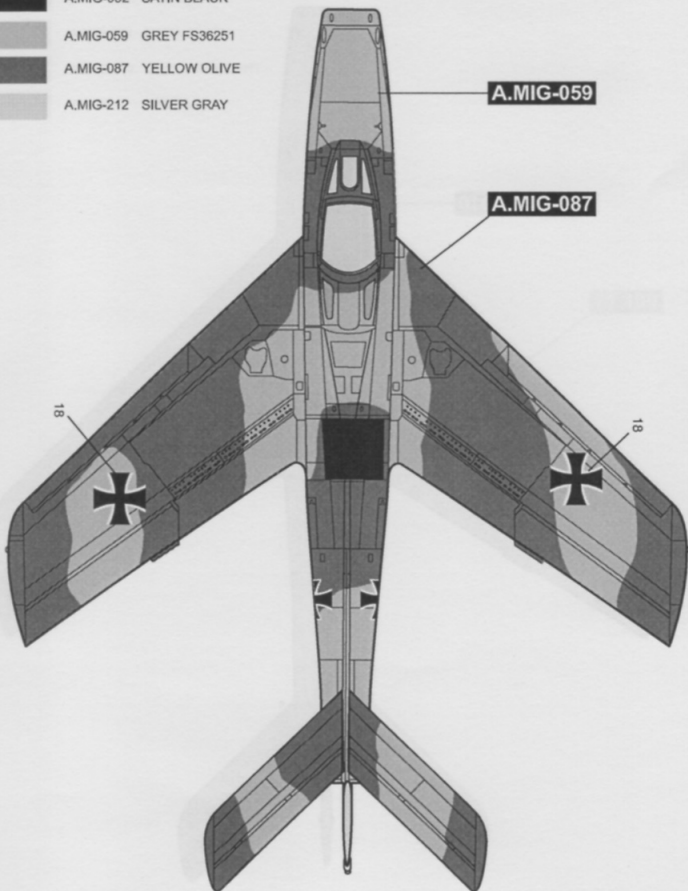

F-84F Thunderstreak, JaboG 34, Memmingen Airbase

- A.MIG-032 SATIN BLACK
- A.MIG-059 GREY FS36251
- A.MIG-087 YELLOW OLIVE
- A.MIG-212 SILVER GRAY



1/48 SCALE AIRCRAFT SERIES NO.K48068

F-84F Thunderstreak Royal Dutch Air Force/Klu N°311 Sqn, Volkel Air Base

-  A.MIG-032 SATIN BLACK
-  A.MIG-084 NATO GREEN
-  A.MIG-910 GREY HIGH LIGHT
-  71.109 PRU BLUE

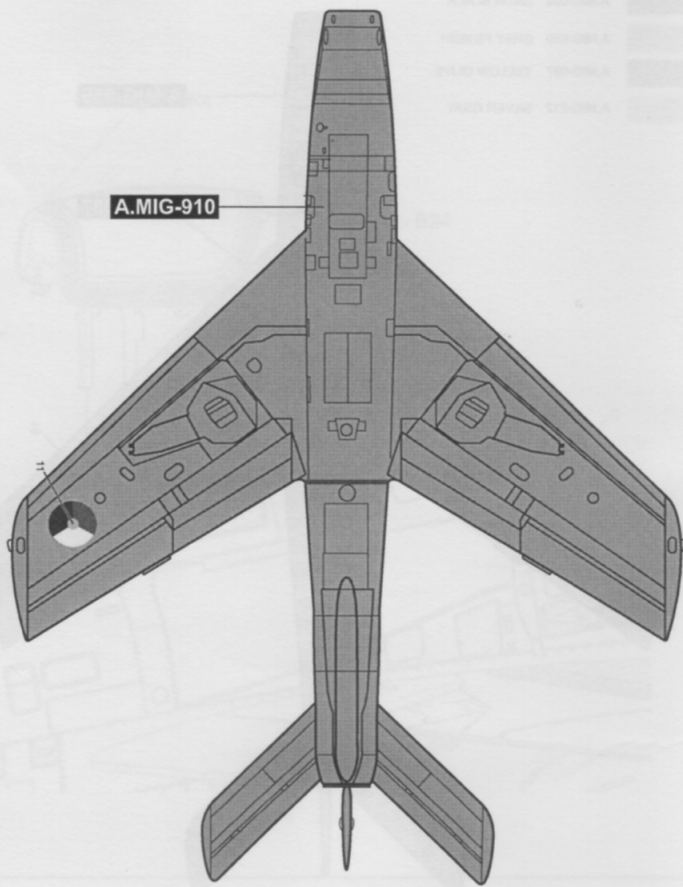
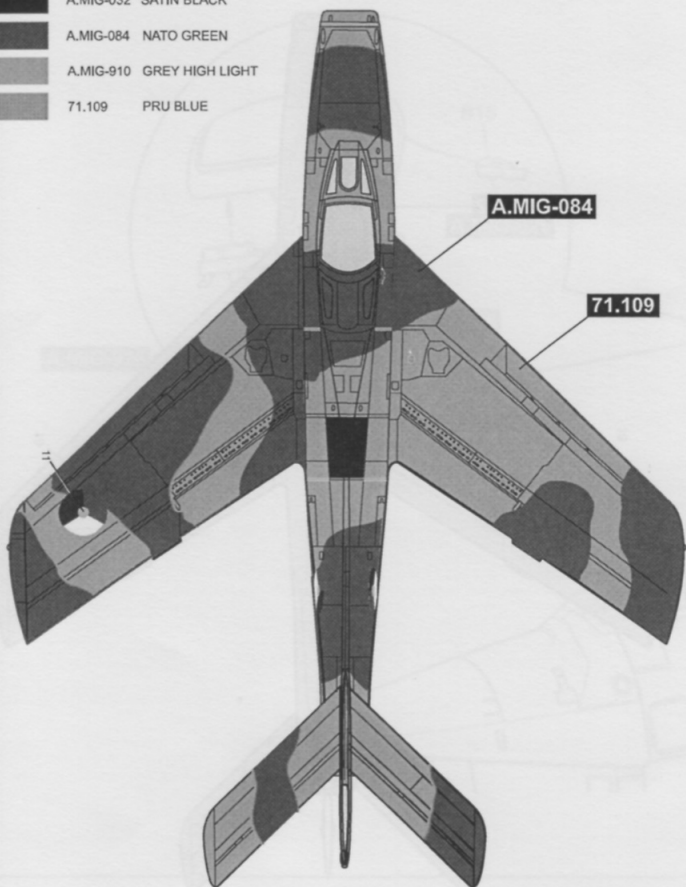



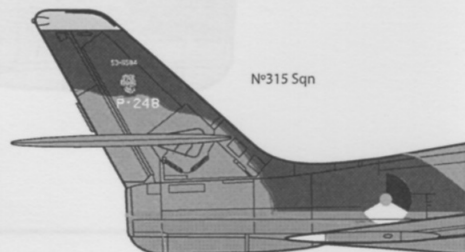
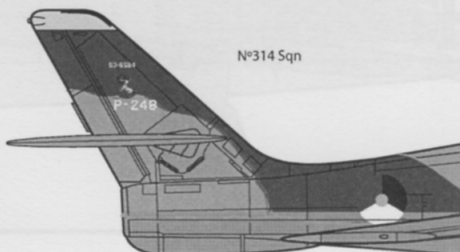
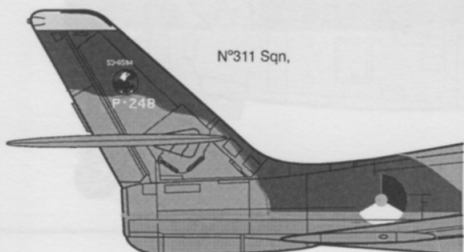
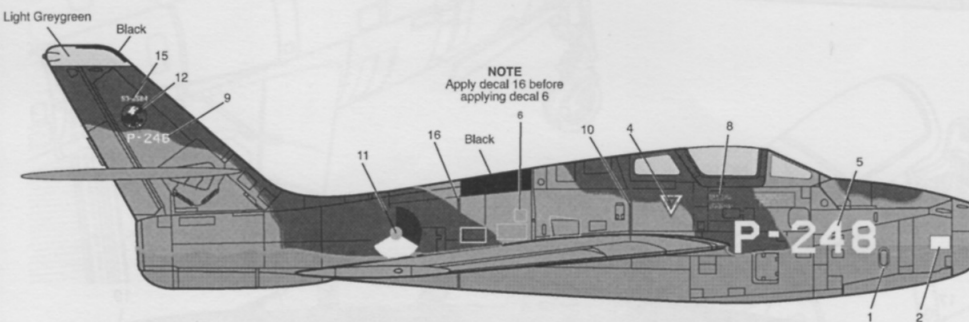
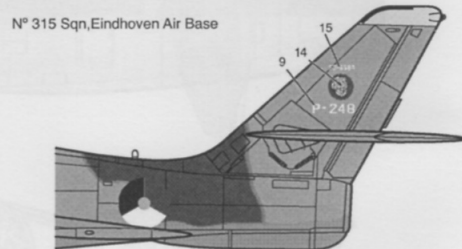
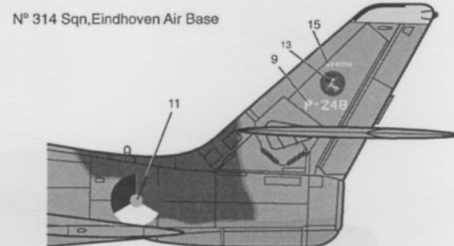
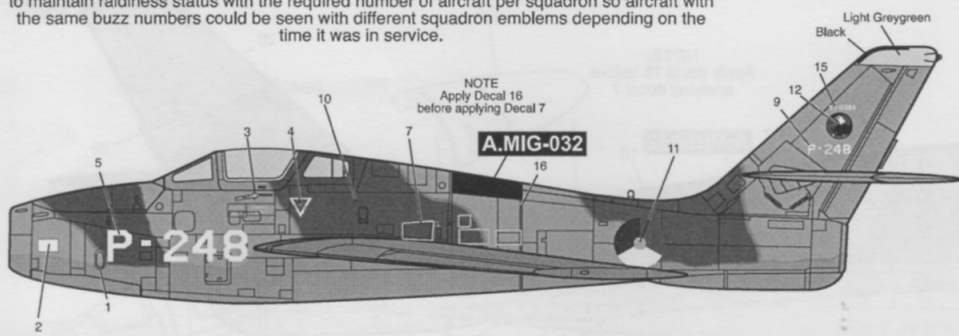

NOTE

Markings are provided for additional squadrons since aircraft rotated between squadrons to maintain raidiness status with the required number of aircraft per squadron so aircraft with the same buzz numbers could be seen with different squadron emblems depending on the time it was in service.



1/48 SCALE AIRCRAFT SERIES NO.K48068

F-84F Thunderstreak Royal Dutch Air Force/Klu N°311 Sqn, Volkel Air Base

-  A.MIG-032 SATIN BLACK
-  A.MIG-084 NATO GREEN
-  A.MIG-910 GREY HIGH LIGHT
-  71.109 PRU BLUE

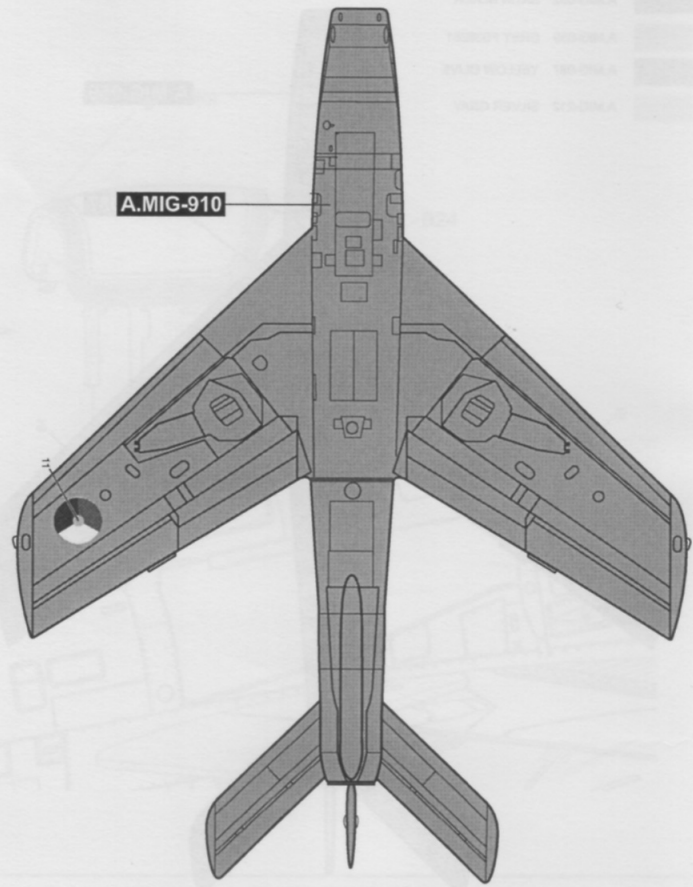
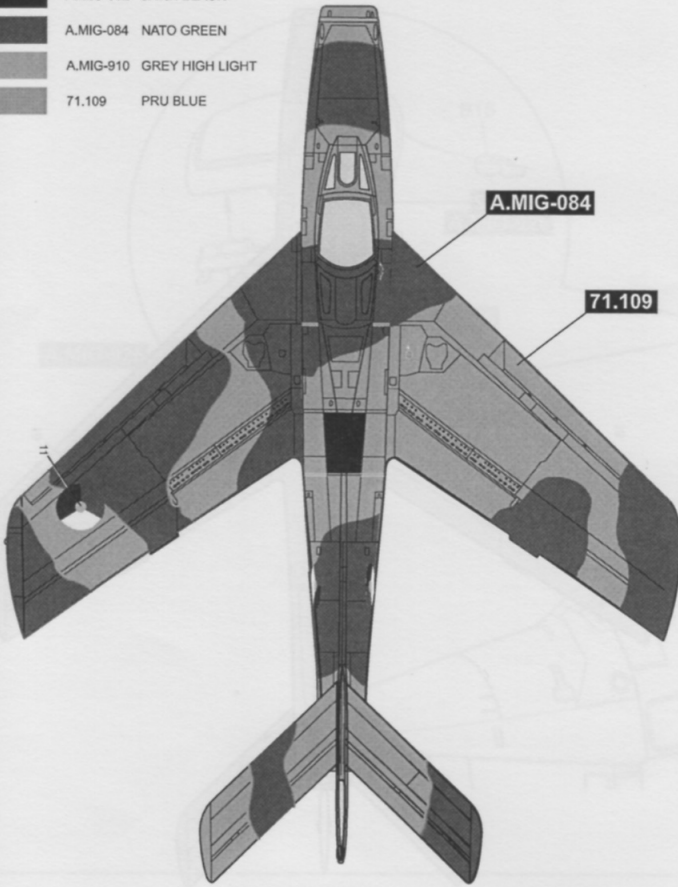

NOTE

Markings are provided for additional squadrons since aircraft rotated between squadrons to maintain readiness status with the required number of aircraft per squadron so aircraft with the same buzz numbers could be seen with different squadron emblems depending on the time it was in service.

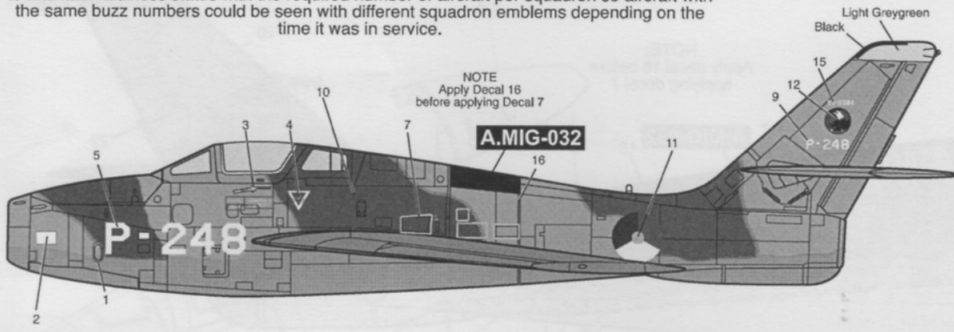

NOTE
Apply Decal 16
before applying Decal 7

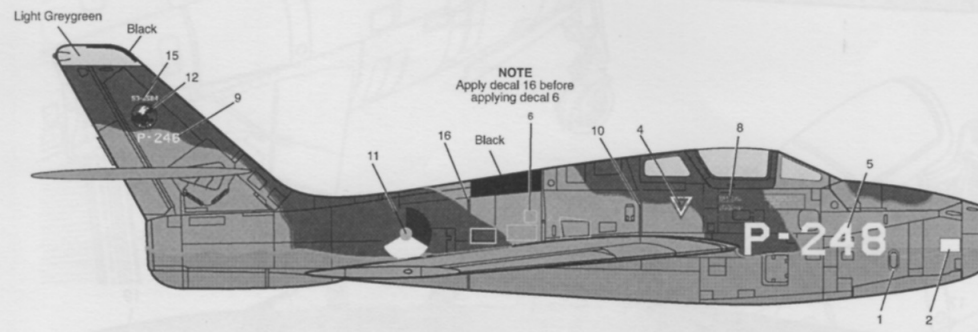
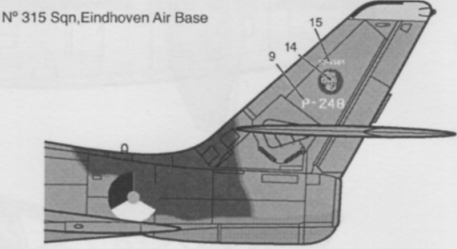
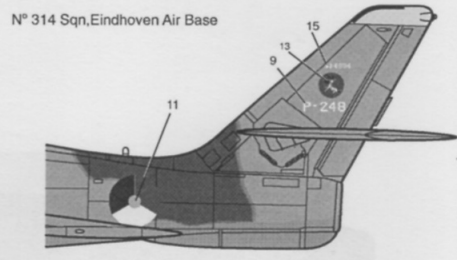



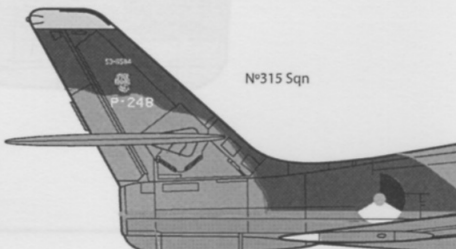
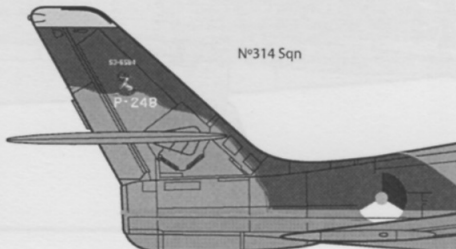
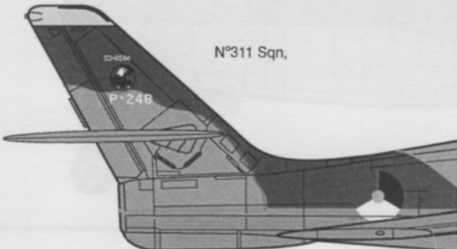

NOTE
Apply decal 16
before applying decal 6



1/48 SCALE AIRCRAFT SERIES NO.K48068

F-84F Thunderstreak Royal Dutch Air Force/Klu N°311 Sqn, Volkel Air Base

-  A.MIG-032 SATIN BLACK
-  A.MIG-084 NATO GREEN
-  A.MIG-910 GREY HIGH LIGHT
-  71.109 PRU BLUE

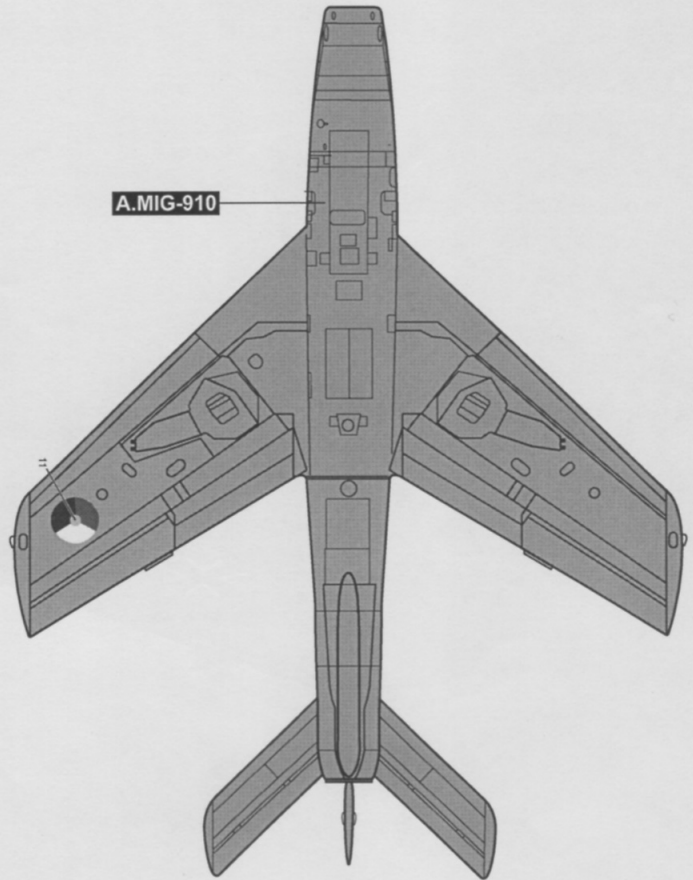
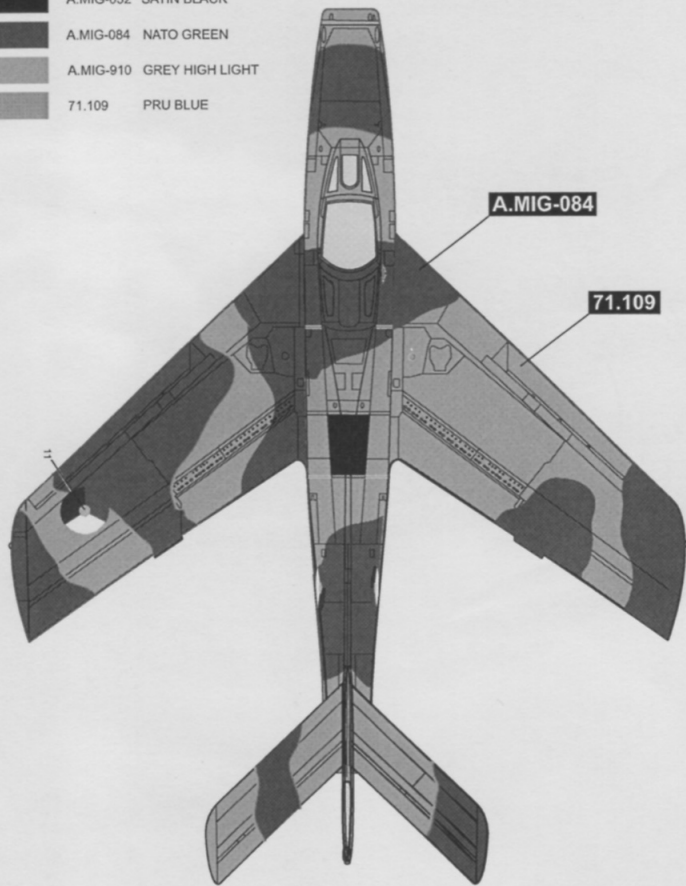

NOTE
Markings are provided for additional squadrons since aircraft rotated between squadrons to maintain raidiness status with the required number of aircraft per squadron so aircraft with the same buzz numbers could be seen with different squadron emblems depending on the time it was in service.

