

**SH 72083**

**Bristol BEAUFORT Mk.Ia and Mk.II**

**1172**

**GB**

The history of the Bristol Beaufort bomber starts from the Bristol type 142 aircraft. This aeroplane, later named *Britania First*, was ordered by Lord Rothermer and in 1935 presented to the RAF. On the bases of testing the type 142 the Bristol company developed the military version 142M, the later type *Blenheim Mk.I*. When the ministry of aviation published the specifications G10/35 for a twin-engine torpedo bomber, Bristol got out of the type 142M and further projects. The arising type 152 was denominated *Beaufort Mk.I*. The all-metal aircraft was driven by *Taurus II* engines, the crew was four men, the armament consisted of the *Mk.XII* torpedo carried half-embedded or bombs carried in the bomb bay and on racks under the wings. The first prototype was first flown on October 15, 1938, serial machines received first the RAF 22 sq. in November 1939.

Gradually were armed further squadrons. All together were manufactured 1014 pieces of the version *Mk.I*. Further 1429 pieces were produced in Great Britain in the version *Mk.II*, with american *P&W R-1830* engines. Further versions were manufactured under licence in Australia. The *Beauforts* were active on the European battlefield against the German naval transport and the *Kriegsmarine* warships. The attacks of the predominate German airforce and anti-aircraft defence caused large losses of these planes. For instance on June 21, 1940 nine *Beauforts* of the RAF 42 sq. attacked the battle-cruiser *Scharnhorst*. The ship was only lightly damaged, but three *Beauforts* were shot down. The most famous action was the attack of a *Beaufort* commanded by F/O Kenneth Campbell against the battle-cruiser *Gneisenau* anchored in *Brest*. The aircraft was shot down by the anti-aircraft defence, but the ship hit by a torpedo was heavily damaged. F/O K. Campbell obtained post-mortem the *Victoria Cross* decoration. Since 1942 *Beauforts* fought successfully also in the Mediterranean and the Indian Ocean.

Technical Specifications:

Span 17,63 m. Length 13,46 m. Height 4,34 m.

Maximum speed was 426 km/h. Normal Range was 2575 km. Service ceiling was 5030 m

**CZ**

Historie torpédového bombardéru Bristol Beaufort se odvíjí od letounu Bristol typ 142. Letoun, později pojmenovaný *Britania First* objednal lord Rothermer a v roce 1935 jej daroval RAF. Na základě zkoušek typu 142 firma Bristol vyvinula vojenskou verzi 142M, pozdější typ *Blenheim Mk.I*. Když ministerstvo letectví vypsallo specifikace G.10/35 na dvoumotorový torpédový bombardér, u Bristolu vyšli z typu 142M a dalších projektů. Vzniklý typ 152 byl pojmenován *Beaufort Mk.I*. Celokovový letoun byl poháněn motory *Taurus II*, osádka byla čtyřčlenná, výzbroj tvořilo torpédo *Mk.XII* nesené polozapuštěné v pumovnici nebo pumy nesené v pumovnici a na závěsnících pod křídly. První prototyp vzletl 15. října 1938, sériové stroje obdržela jako první 22.sq. RAF v listopadu 1939. Postupně byly vyzbrojovány další squadrony. Celkem bylo vyrobeno 1014 kusů verze *Mk.I*. Další 1429 kusů bylo v Británii vyrobeno ve verzi *Mk.II*, s americkými motory *P&W R-1830*. Další verze byly licenčně vyráběny v Austrálii.

*Beauforty* byly na evropském válečném poli proti německé loďní dopravě a válečným lodím *Kriegsmarine*. Útoky v převaze německého letectva a protivzdušné obrany jim přinášely velké ztráty. Například 21. června 1940 zaútočilo devět *Beaufortů* 42.sq. RAF na bitevní křižník *Scharnhorst*. Loď byla jen lehce poškozena, ale tři *Beauforty* byly sestřeleny. Nejslavnější akcí byl útok *Beaufortu* pilotovaného F/O Kenneth Campbell na bitevní křižník *Gneisenau* kotvící v *Brestu*. Letoun byl sestřelen protivzdušnou obranou, ale torpédem zasažená loď byla těžce poškozena. F/O K. Campbell obdržel posmrtné vyznamenání *Victoria Cross*.

Od roku 1942 bojovaly úspěšně *Beauforty* také ve Středomoří a v Indickém oceánu.

Technické údaje:

Rozpětí 17,63 m. Délka 13,46 m. Výška 4,34 m.

Maximální rychlost 426 km/hod. Normální dolet 2575 km. Operační dostup 5030 m

# DILY - PARTS - TEILE - PIÉCES

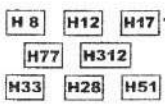
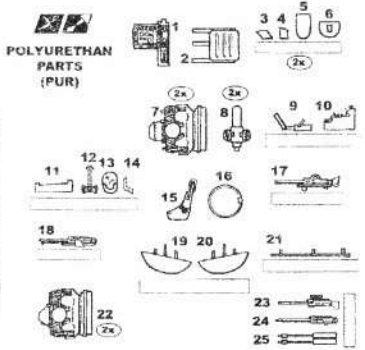
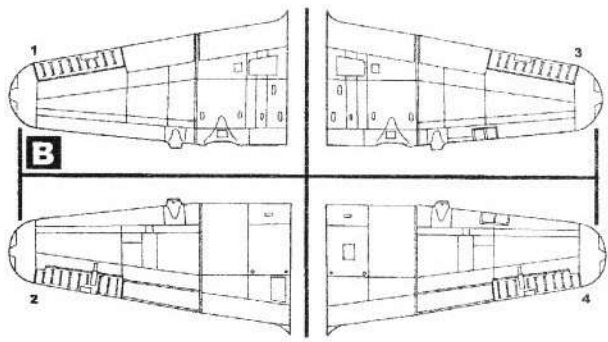
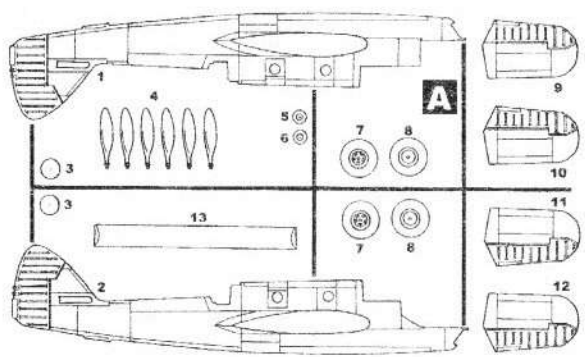
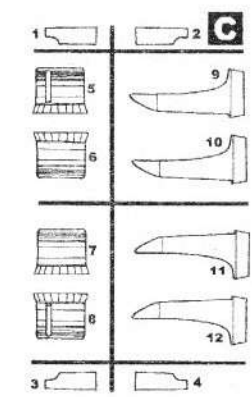
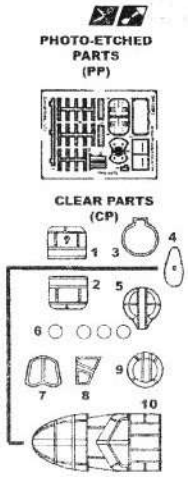
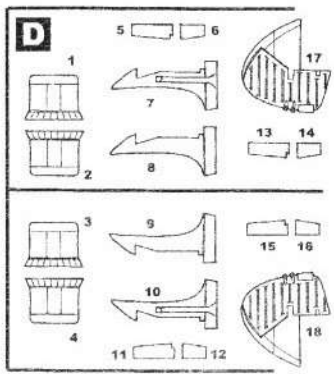
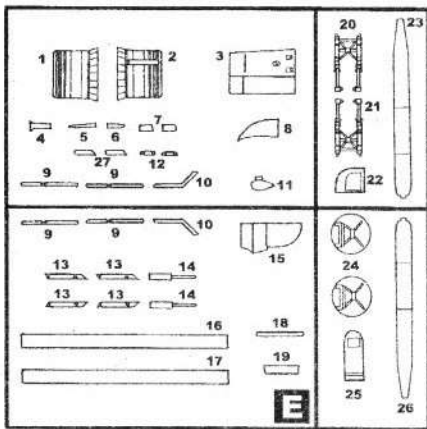

# SESTAVA - ASSEMBLY - BAUANLEITUNG - ASSEMBLAGE

1

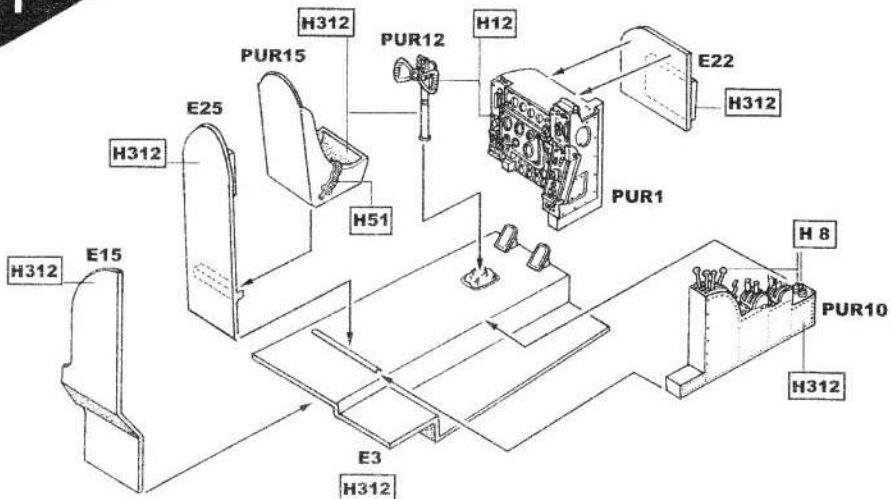

2

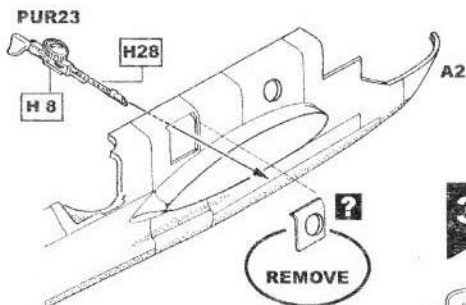

3

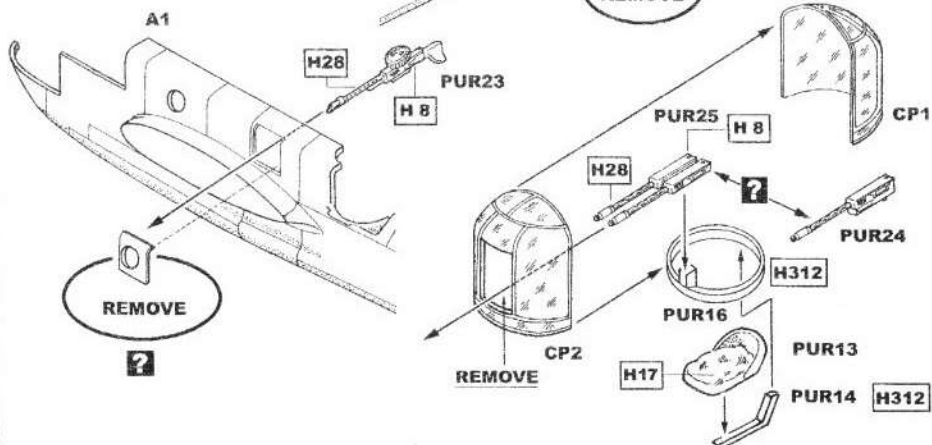

4

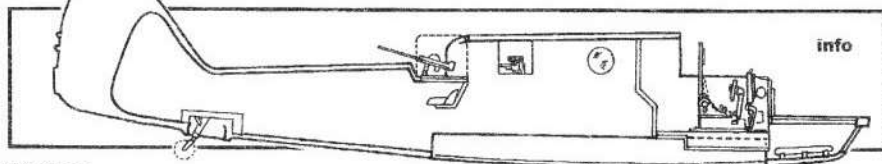
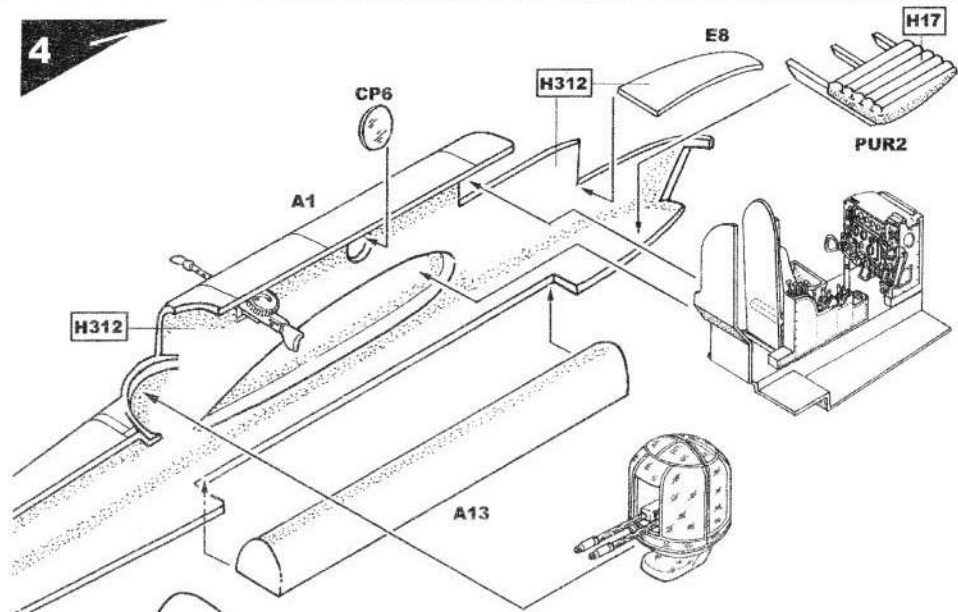

5

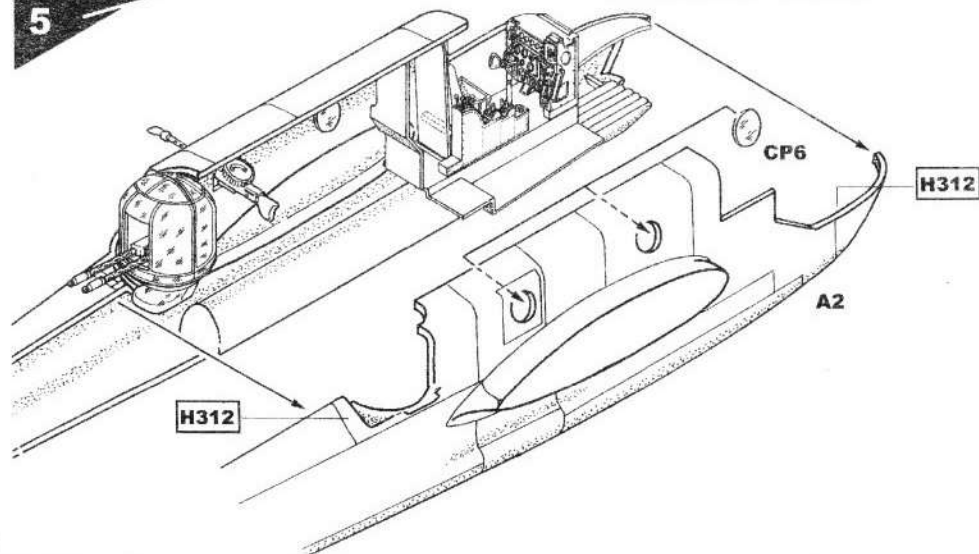

# SESTAVA - ASSEMBLY - BAUANLEITUNG - ASSEMBLAGE

6

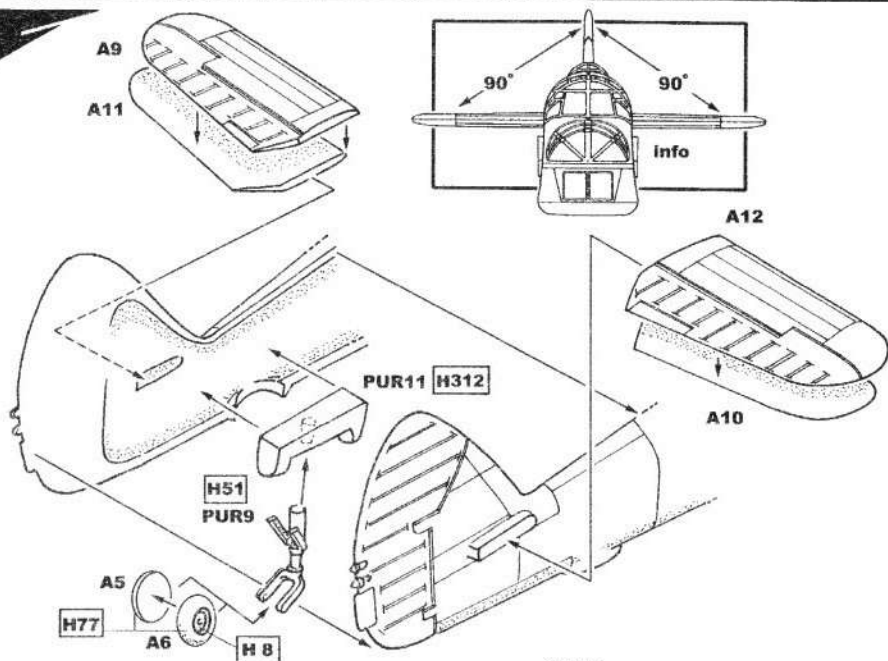

?  
Kamufáž  
Camouflage  
"C"

7

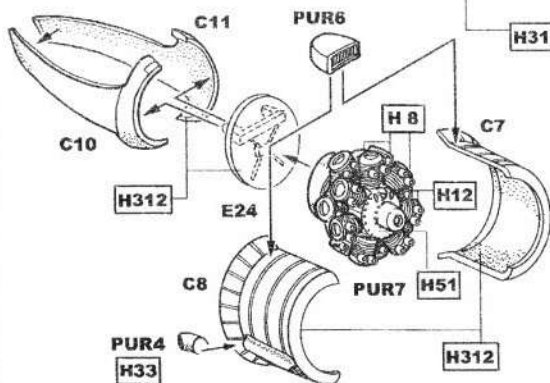
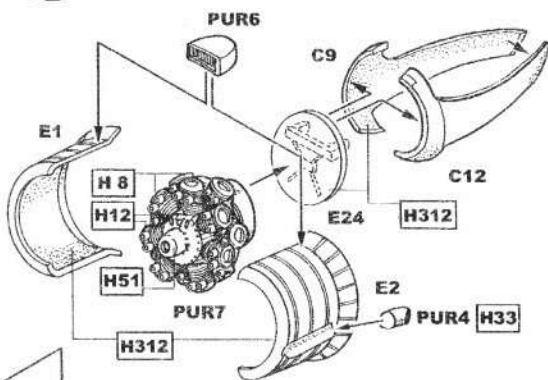

8

?  
Kamufáž  
Camouflage  
"C"

**?**  
Kamufáž  
Camouflage  
"A,B"

**9**

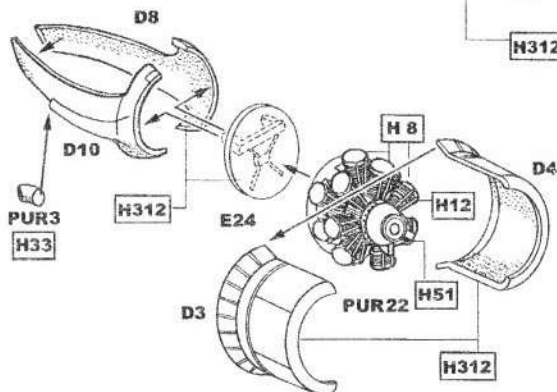
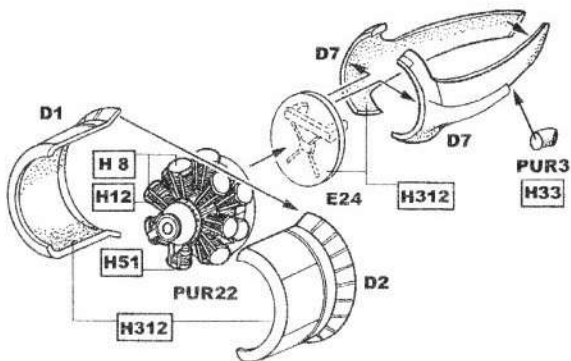

**10**

**?**  
Kamufáž  
Camouflage  
"A,B"

**11**

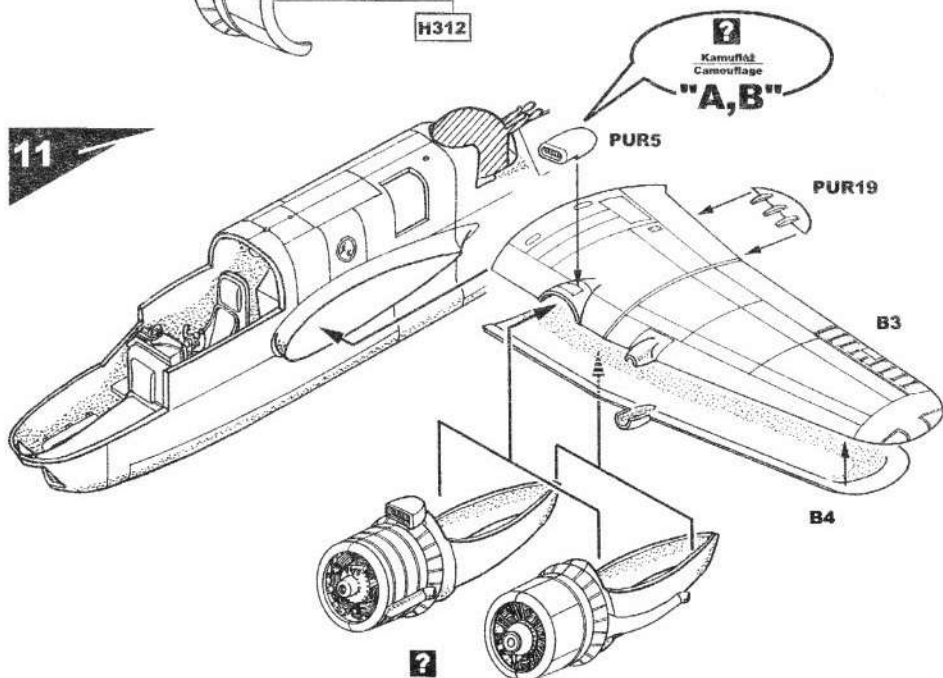

**?**

12

?

Kamufáž  
Camouflage

"A,B"

PUR5

PUR20

B1

B2

?

ořní

info

13

?

Kamufáž  
Camouflage

"C"

PRAVÝ MOTOR  
RIGHT ENGINE

LEVÝ MOTOR  
LEFT ENGINE

A4

A4

A3

A3

PUR8  
H 8

PUR8  
H 8

A4

A4

A4

A4

14

?  
Kamufliáž  
Camouflage  
"A,B"

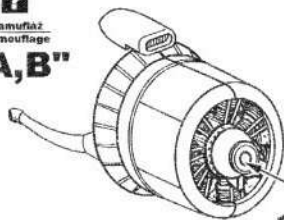

PRAVÝ MOTOR  
RIGHT ENGINE

PUR8  
H 8

A4

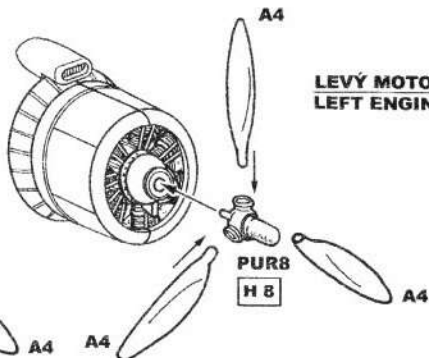

LEVÝ MOTOR  
LEFT ENGINE

PUR8  
H 8

A4

15

REMOVE

?

CP10

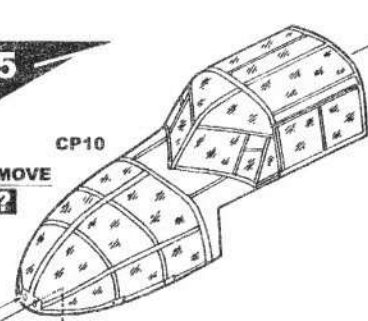

CP8

PUR25

H 8

H28



CP7



E19

E11

E5



DRAWING:BA

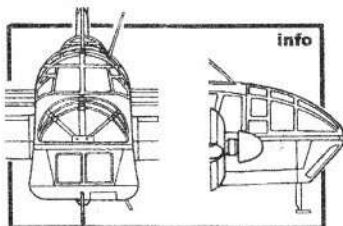

info



16

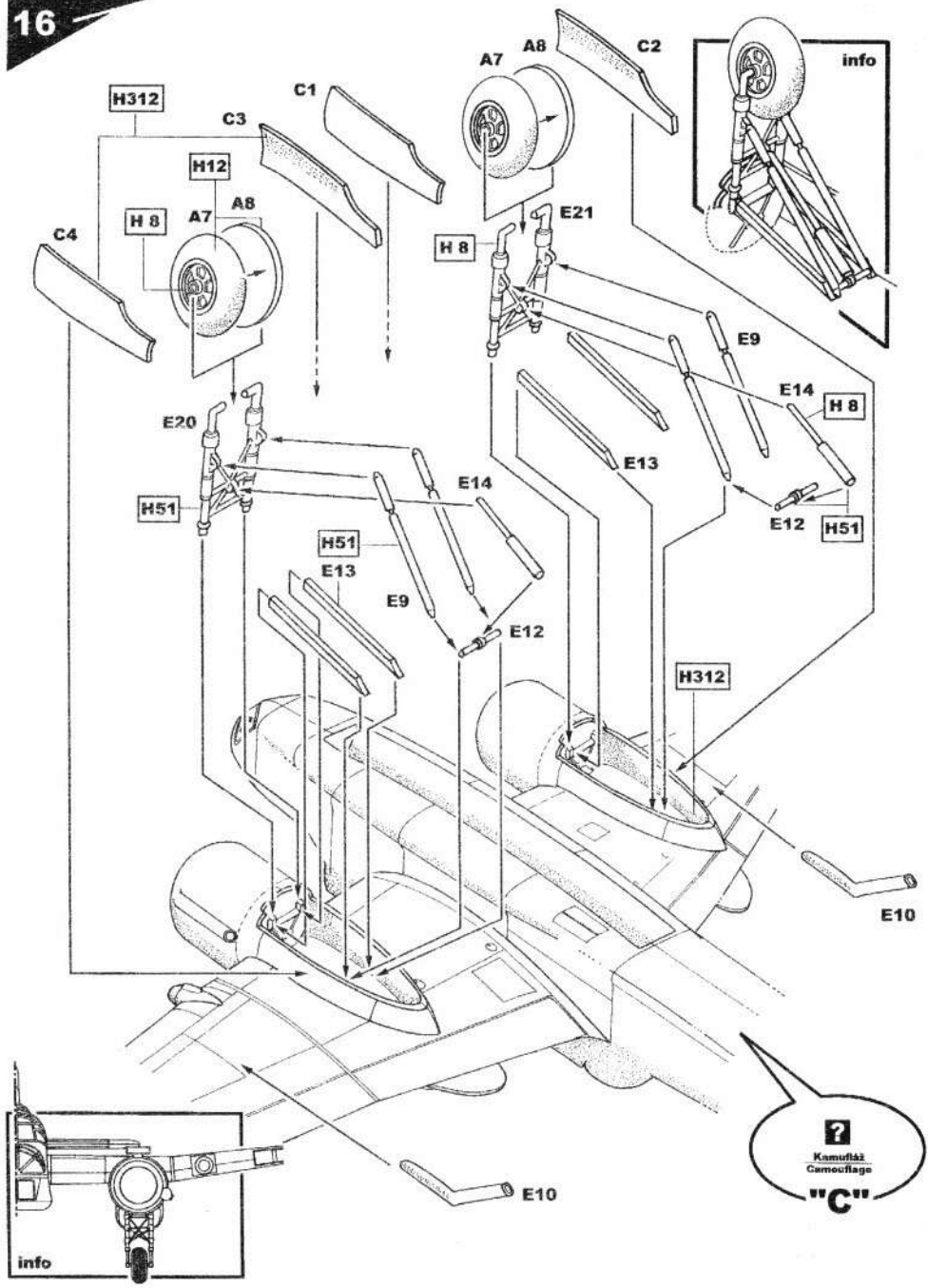

17

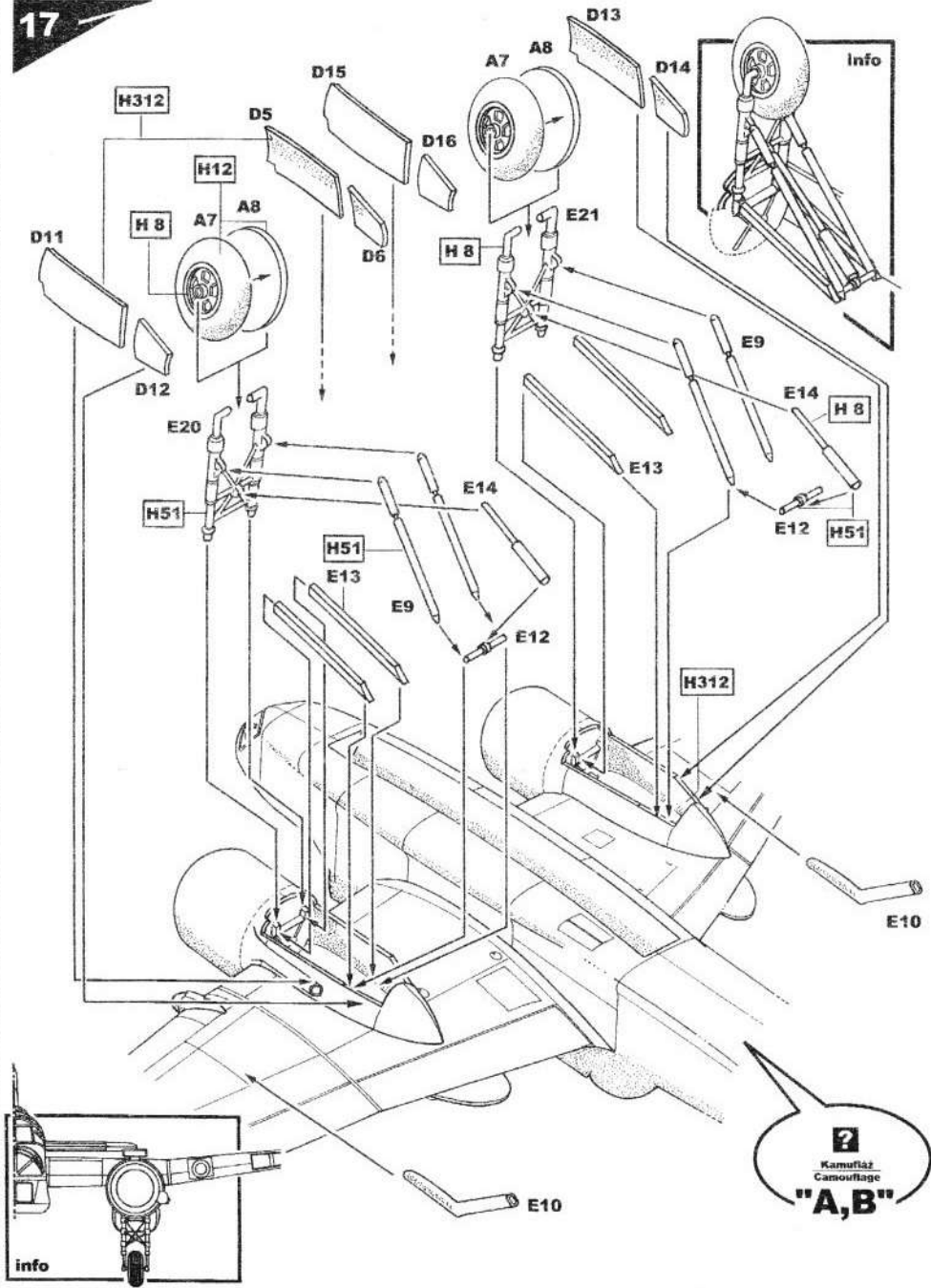

18

info

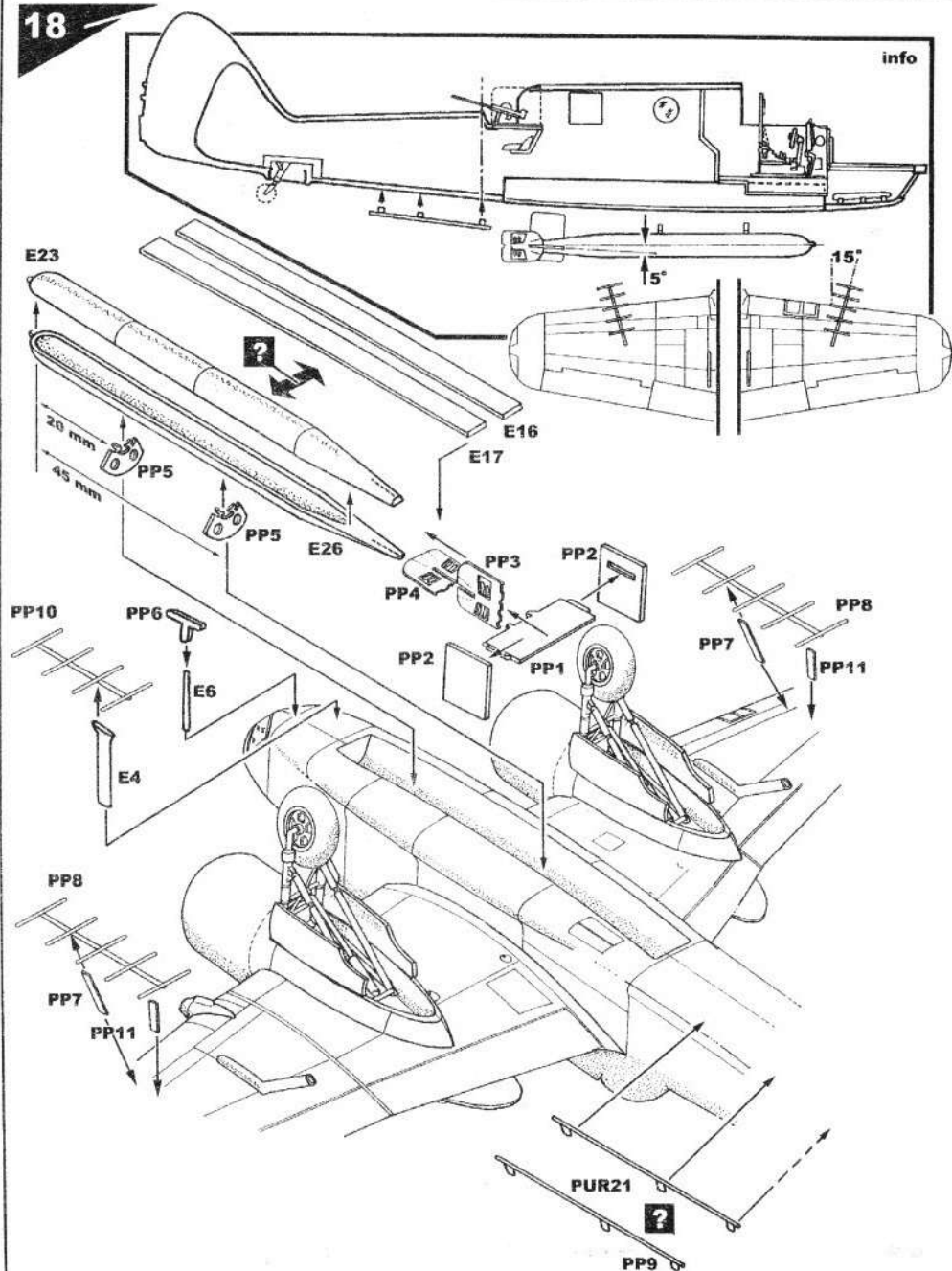

# ZBARVENÍ a OZNAČOVÁNÍ

CAMOUFLAGE and MARKING, TARNUNG und KENNUNG, CAMOUFLAGE et DESIGNATION



Bristol Beaufort Mk.II A, AW 347, BX-S, 86. sq. RAF základna Skitten, Skotsko, Velká Británie, jaro 1942.  
Bristol Beaufort Mk.II A, AW 347, BX-S, 86th Squadron, Skitten airbase, Scotland, Spring 1942.

cam.A

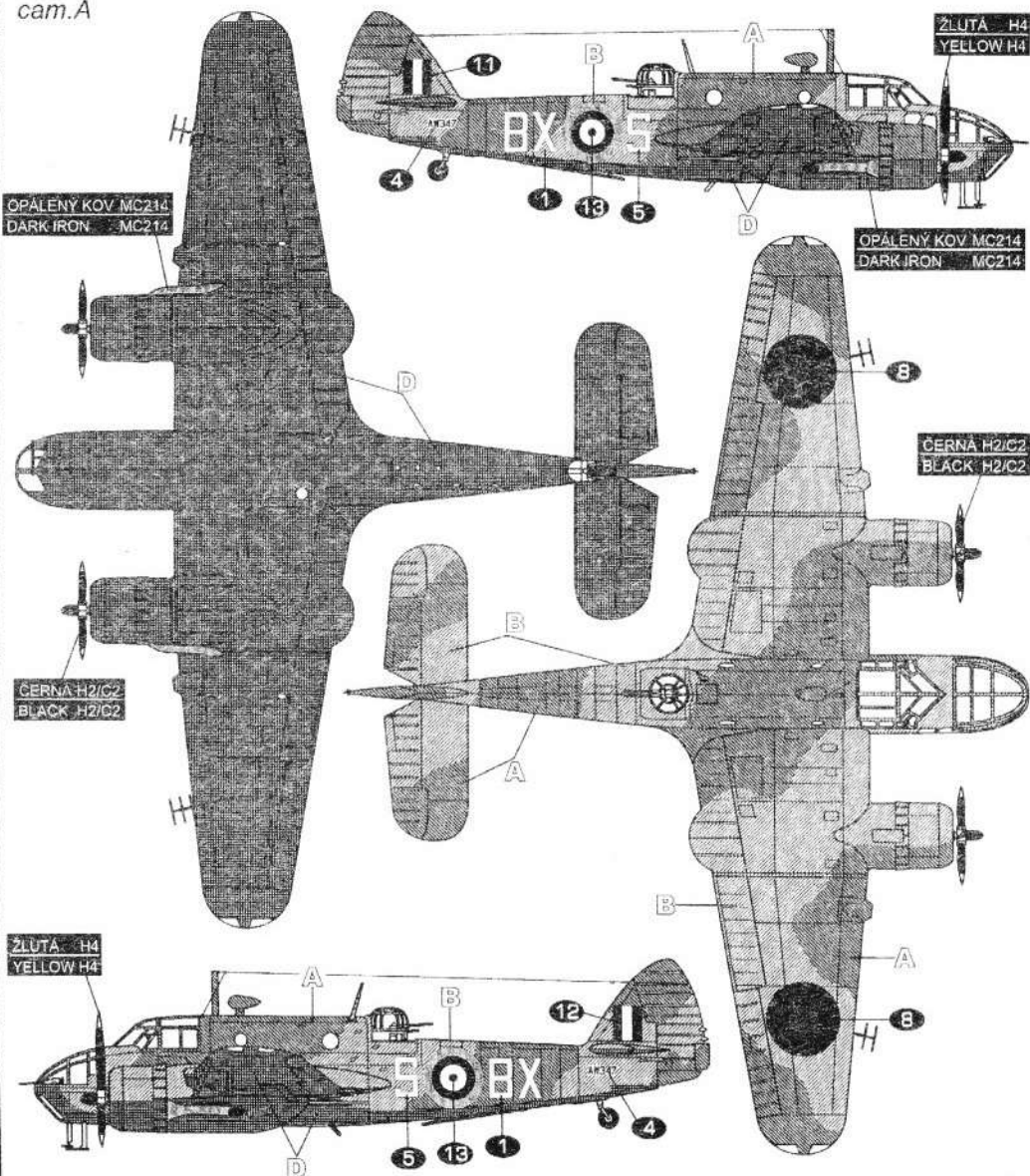

OPÁLENÝ KOV MC214  
DARK IRON MC214

ŽLUTÁ H4  
YELLOW H4

OPÁLENÝ KOV MC214  
DARK IRON MC214

ČERNÁ H2/C2  
BLACK H2/C2

ČERNÁ H2/C2  
BLACK H2/C2

ŽLUTÁ H4  
YELLOW H4

**D**  
H12/C12 Černá  
Black

**A**  
H78/C38 50%  
H32/C40 50% Tmavá břidlicová  
šedá  
Dark Slate Grey

**B**  
H333/C333 Velmi tmavá  
mořská šedá  
Extra Dark  
Sea Grey

info  
Barvy GUNZE  
GUNZE colours No

# ZBARVENÍ a OZNAČOVÁNÍ

CAMOUFLAGE and MARKING, TARNUNG und KENNUNG, CAMOUFLAGE et DESIGNATION



Bristol Beaufort Mk.II A, DD 896, G, 39. sq. RAF, základna Luga, Malta, konec roku 1942.  
Bristol Beaufort Mk.II A, DD 896, G, 39th Squadron, Luqa airbase, Malta, end of 1942.

cam.B

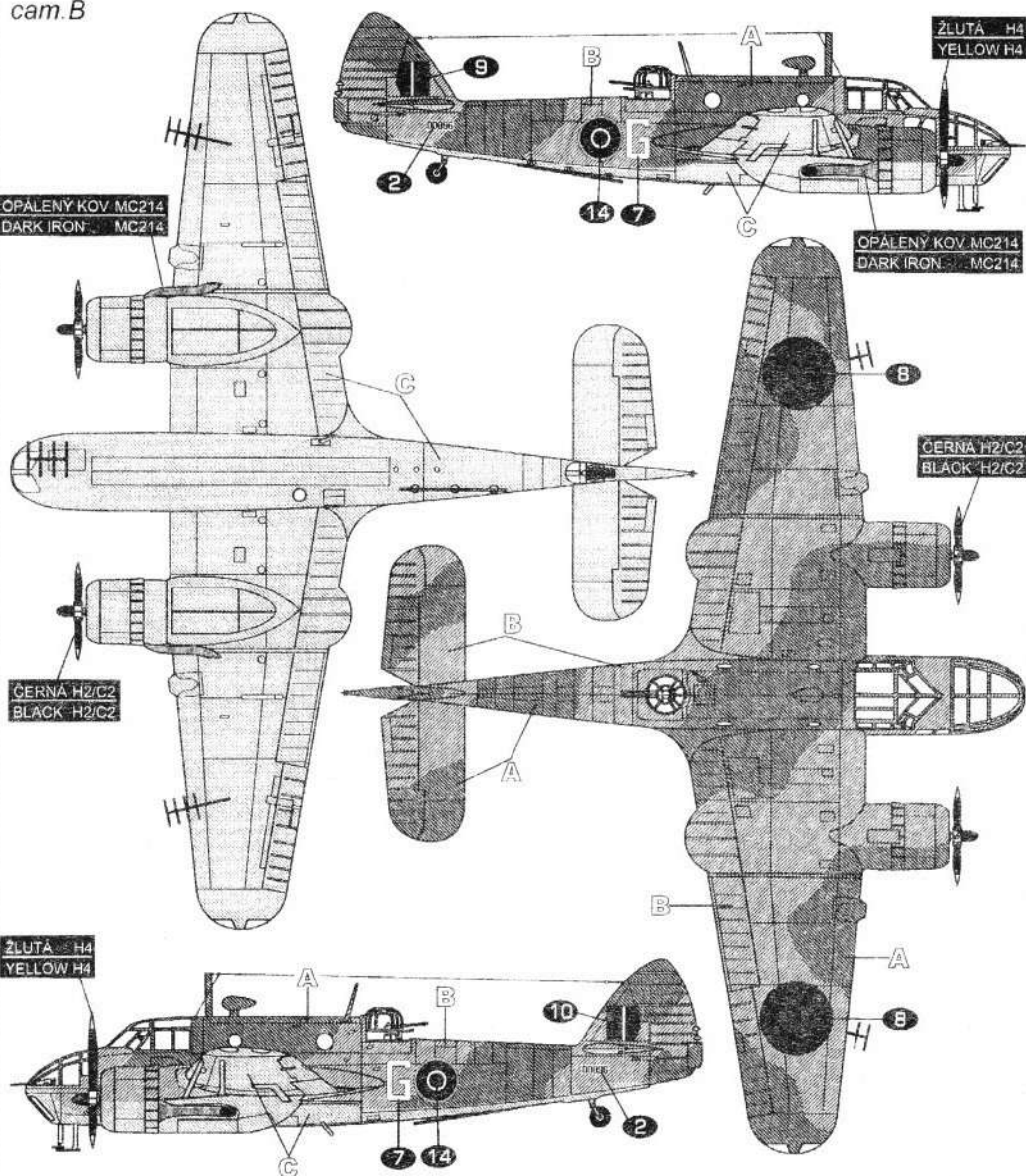

OPALENÝ KOV MC214  
DARK IRON MC214

ŽLUTÁ H4  
YELLOW H4

OPALENÝ KOV MC214  
DARK IRON MC214

ČERNÁ H2/C2  
BLACK H2/C2

ČERNÁ H2/C2  
BLACK H2/C2

ŽLUTÁ H4  
YELLOW H4

**A** Tmavá břidlicová šedá  
H78/C38/50%  
H32/C40/50% Dark Slate Grey

**B** Velmi tmavá mořská šedá  
H333/C333 Extra Dark Sea Grey

**C** Azurově modrá  
H370/C370 Azure Blue

info  
Barvy GUNZE  
GUNZE colours No.

# ZBARVENÍ a OZNAČOVÁNÍ

## CAMOUFLAGE and MARKING TARNUNG und KENNUNG CAMOUFLAGE et DESIGNATION



Bristol Beaufort Mk.I A, DD 959, Q, 217. Sq. RAF, základna Luga, Malta 1942. Dne 20. června byl tento letoun sestřelen Junkersem Ju 88.  
 Bristol Beaufort Mk.I A, DD 959, Q, 217th Squadron, Luqa airbase, Malta 1942. This aircraft was shot down by Junkers Ju 88 on June 20th.

cam.C

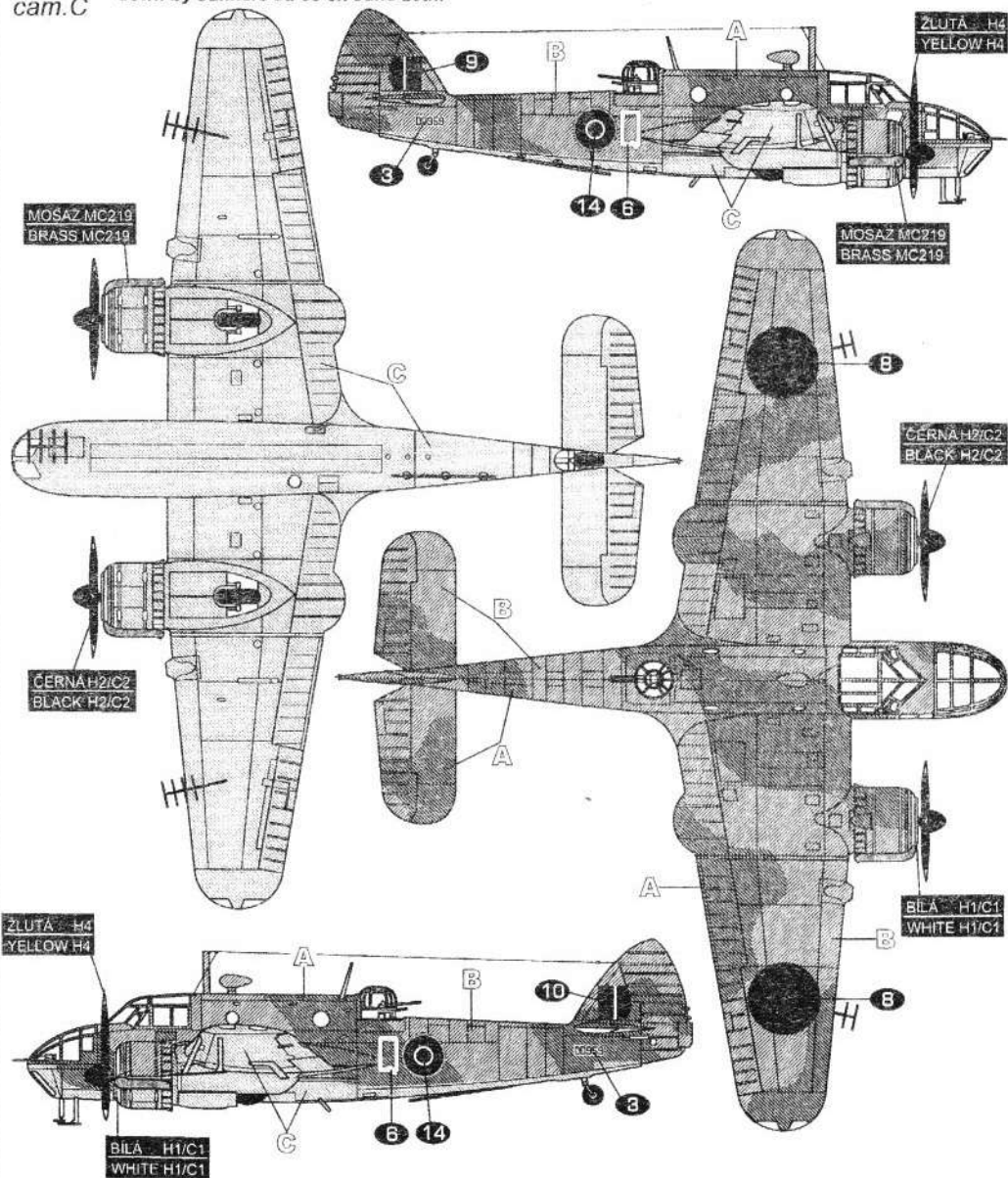

**A** Tmavá břidlicová šedá  
 H78/C38 50%  
 H32/C40 50%  
 Dark Slate Grey

**B** Velmi tmavá mořská šedá  
 H333/C333  
 Extra Dark Sea Grey

**C** Azurové modrá  
 H370/C370  
 Azure Blue

Info  
 Barvy GUNZE  
 GUNZE colours No.