

B-26B Marauder

1/48 SCALE MODEL KIT No 48320

B-26B Marauder

Американський бомбардувальник 2 СВ

Американський двомоторний середній бомбардувальник B-26 виробництва Glenn L. Martin Company, проектувався та створювався у 1939 році під вимоги Авіаційного корпусу Армії США на новий швидкісний середній бомбардувальник. Перший B-26 піднявся в повітря 25 листопада 1940 року, а на озброєння авіації США він був прийнятий у лютому 1941 року. У процесі експлуатації конструкція бомбардувальника постійно змінювалася з метою покращення льотних та бойових характеристик. З 1943 року було збільшено площу крила та киль, із цими змінами літак випускався вже до кінця виробництва. Остання модифікація B-26B Marauder (B-26B-55-MA) випускалася до лютого 1944 року, ці літаки брали активну участь у бомбардувальних операціях США в Європі на заключному етапі Другої світової війни.

Тактико-технічні характеристики B-26B Marauder

Довжина, м	17,76
Розмах крила, м	21,64
Нормальна злітна вага, кг	16783
Двигуни	2 x Pratt & Whitney R-2800-43, 2x1920 к.с.
Максимальна швидкість	454 км/год
Практична стеля, м	6614
Дальність польоту, км	1850
Озброєння	11 x 12,7 мм кулеметів, до 1814 кг бомб

B-26B Marauder

WWII American Bomber

American twin-engine medium bomber B-26, manufactured by the Glenn L. Martin Company, was designed and created in 1939 under the requirements of the US Army Air Corps for a new high-speed medium bomber. The first B-26 flew on November 25, 1940, and it was adopted by US aviation in February 1941. During operation, the design of the bomber was constantly changed to improve flight and combat characteristics. Since 1943, the wing area and keel were increased, with these changes, the aircraft was produced until the end of production. The last modification of the B-26B Marauder (B-26B-55-MA) was produced until February 1944; these aircraft took an active part in US bomber operations in Europe at the final stage of World War II. B-26B Marauder aircraft are known as one of the most famous US bombers during the Second World War.

Tactical and Technical Specifications of B-26B Marauder

Length, m	17,76
Wingspan, m	21,64
Max take-off weight, kg	16783
Engines	2 x Pratt & Whitney R-2800-43, 2x1920 hp
Max. Speed, km/h	454 km/h
Service Ceiling, m	6614
Max ferry range, km	1850
Armament	11 x 12.7 mm machine guns, up to 1814 kg of bombs

ФАРБИ, ЩО ВИКОРИСТОВУЮТЬСЯ / USED COLORS:

COLOR	ICM
A Білий White	1001
B Чорний Black	1002
C Жовтий Deep Yellow	1003
D Алюміній Aluminium	1023
E Срібло Silver	1024
F Сталь Natural Steel	1025
G Масляна сталь Oily Steel	1026
H Збройовий метал Gun metal	1027
J Червоний Deep Red	1007
K Біло-сірий White Grey	1029
L Темно-морський сірий Dark Sea Grey	1034
M Гумовий чорний Rubber Black	1039
N Оливковий Olive Green	1068
P Камуфляжний Camouflage Green	1071
Q US Темно-зелений US Dark Green	1072

COLOR	ICM
R Блідо-синій Pale Blue	1074
S Напівпрозорий червоний Clear Red	1011
T Напівпрозорий зелений Clear Green	1014
U Нейтральний сірий Neutral Grey	1036
W Напівпрозорий помаранчевий Clear Orange	1016

Для отримання глянцевого, сатинового чи матового ефекту – використовуйте наші лаки!

For a glossy, satin or matte effect – use our varnishes!

01 СТАДІЯ СКЛАДАННЯ
ASSEMBLY STEP

A ФАРБА, ЩО ВИКОРИСТОВУЄТЬСЯ
USED COLOR

x2 ЗРОБИТИ ДВІ ДЕТАЛІ
MAKE 2 PCS

NE НЕ КЛЕЇТИ
DO NOT CEMENT

03 СКЛАДАЛЬНА ОДИНИЦЯ
ASSEMBLY UNIT

***** ЗРОБИТИ САМОМУ
SCRATCH BUILD

H ПРОСВЕРДЛИТИ
OPEN HOLE

C ВІДРІЗАТИ
CUT OFF

У В А Г А І С А У Т І О Н І

Перед складанням уважно прочитати інструкцію з монтажу. Кожна деталь пронумерована. Дотримуватися послідовності монтажу. Необхідні робочі інструменти: ніж і напилець для зачистки деталей; гумова стрічка, клеюча стрічка і прищипки для білених (для притиснення склеюваних деталей). Деталі з пластику очистити в розчині м'якого миючого засобу і висушити на повітрі для того, щоб фарба і перерізані картини краще прилипали. Перед приклеюванням перерізи, чи підготувати деталі, клей наносити економно. Хром і фарбу віддалити з поверхні склеювання. Невеликі деталі пофарбувати перед тим, як вони будуть вдалені з рамки. Фарбу необхідно добре просушити, тільки після цього продовжувати складання. Кожну відповідну перерізану картинку вирізати окремо і приблизно на 20 секунд занурити в теплу воду. На позначеному місці картинку відокремити від паперу і притиснути промокальним папером.

Read the instructions thoroughly prior to assembly. Each component is numbered. Adhere to specified sequence of assembly. Tools required: knife and file for removal of components from frame; rubber bond, adhesive tape and clothes pegs for clamping components together after applying adhesive. Clean plastic components in a mild detergent solution and allow to air-dry so that paint and transfers adhere better. Prior to applying adhesive, check to see whether the components fit together, apply adhesive sparingly. Remove chrome and paint from the contact surfaces. Paint small components before removing them from the frame. Allow paint to dry well, and only then continue to assemble. Cut out each transfer individually and immerse in warm water for approx. 20 seconds. Slide transfer off paper and into designated position, then press on with blotting paper.

Використовуйте набір фарб від ICM
Best to be used with ICM Paint Set



2001
МАТОВИЙ ЛАК
VARNISH MATT



2002
САТИНОВИЙ ЛАК
VARNISH SATIN



2003
ГЛЯНЦЕВИЙ ЛАК
VARNISH GLOSS

Покрокова
відеоінструкція тут



Step-by-step video
Instruction here

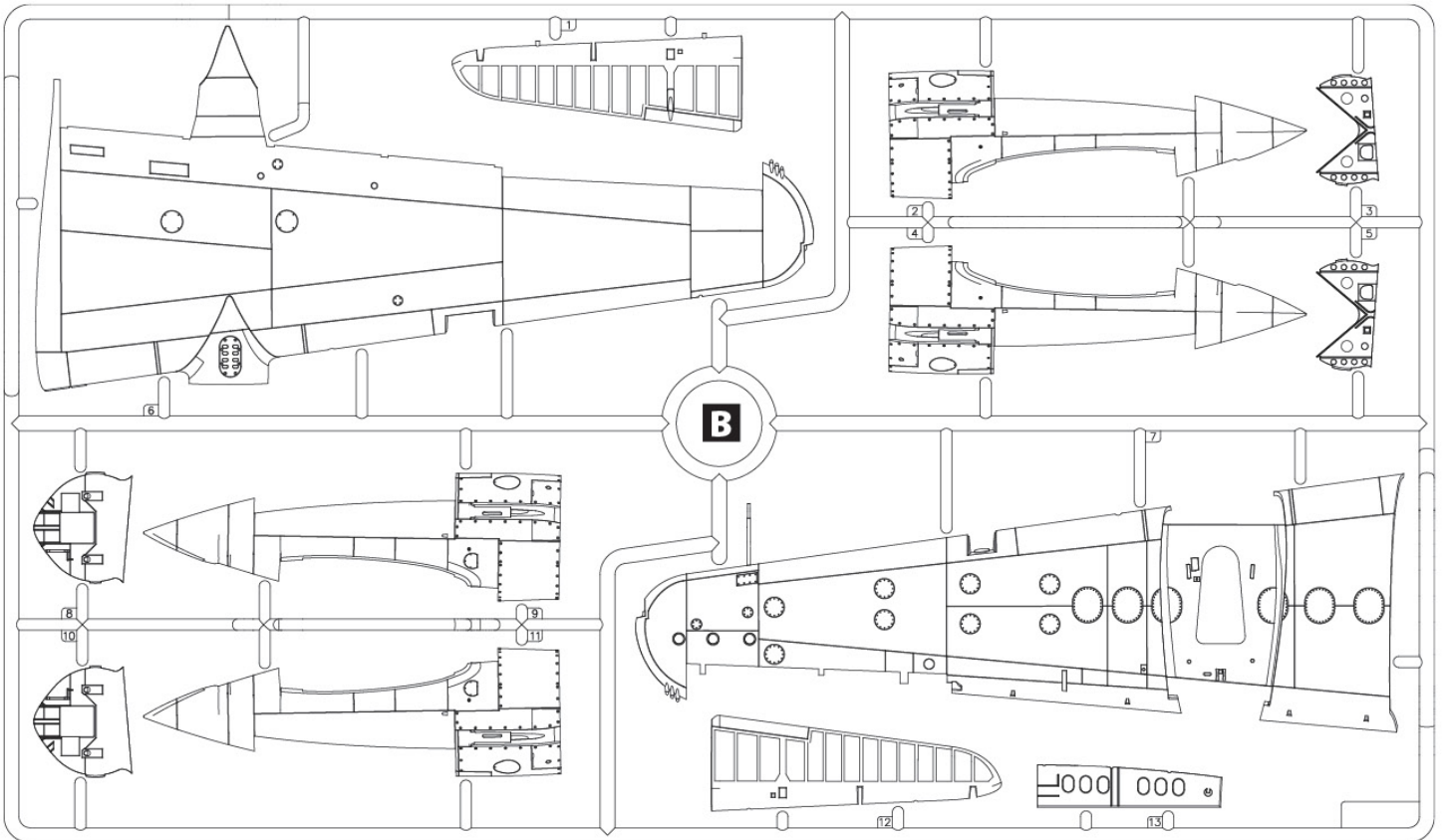
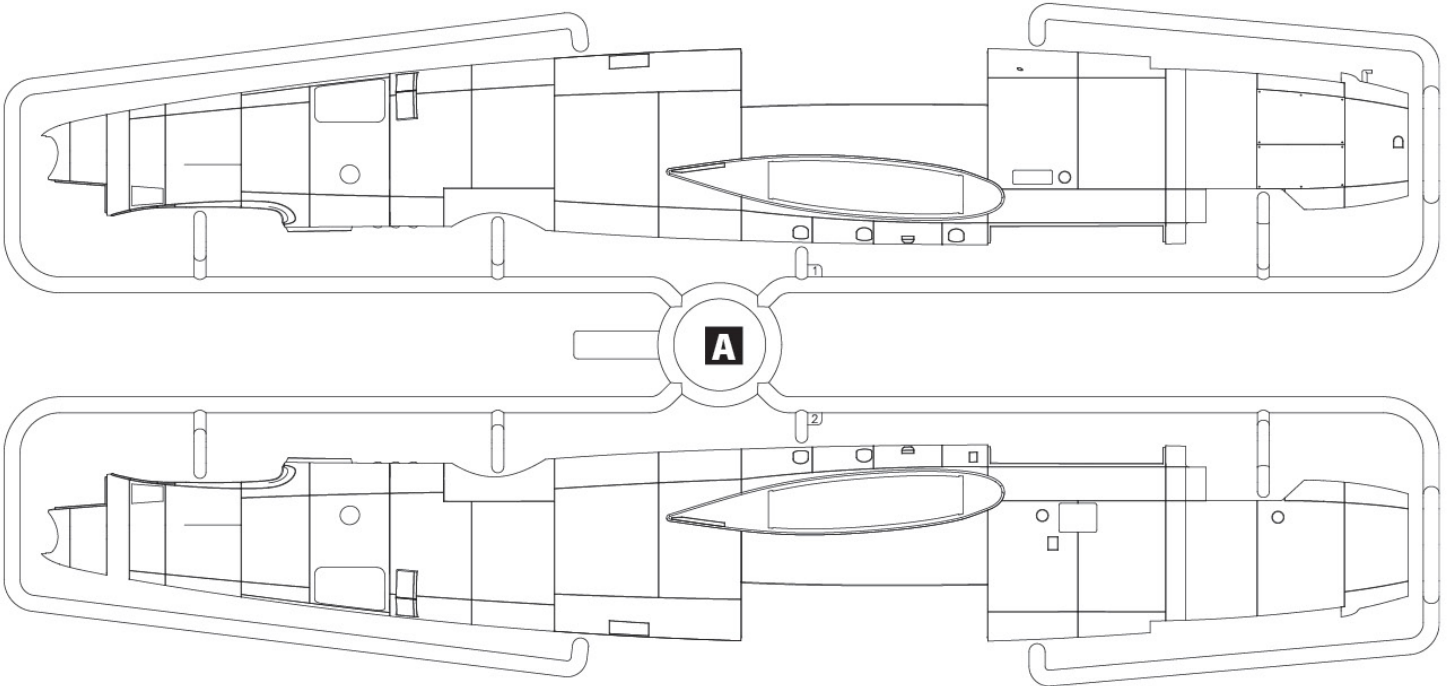

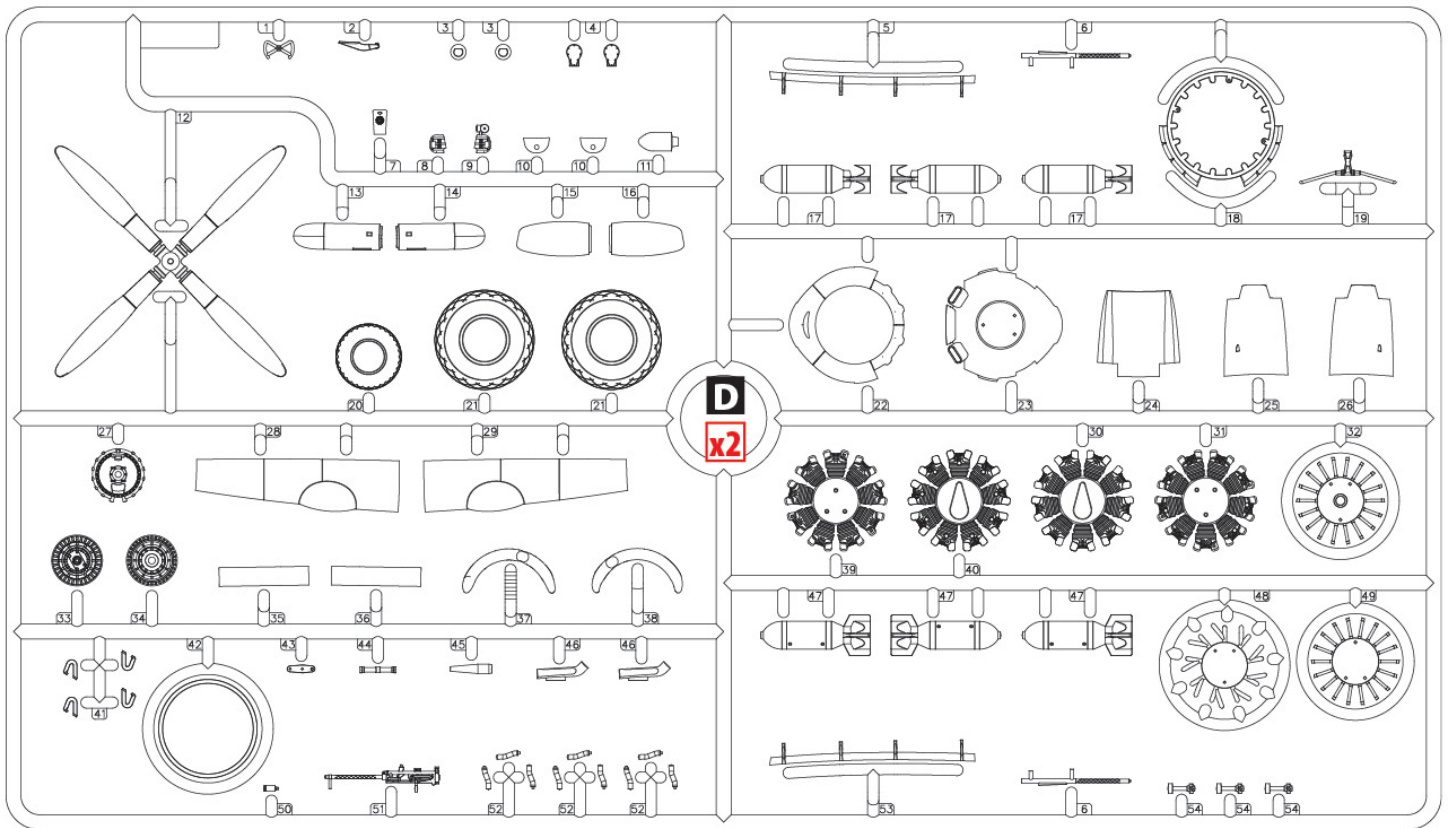
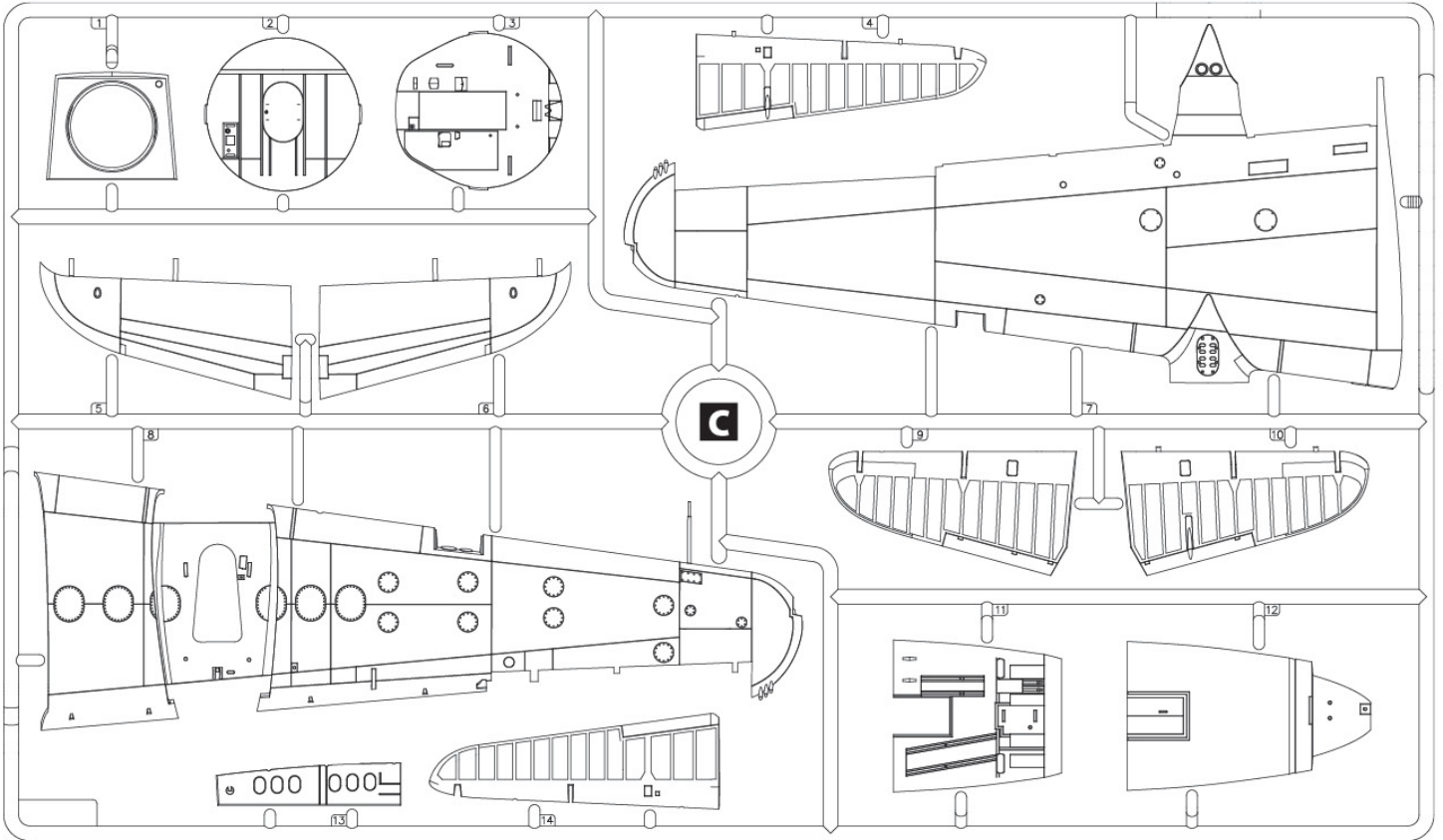

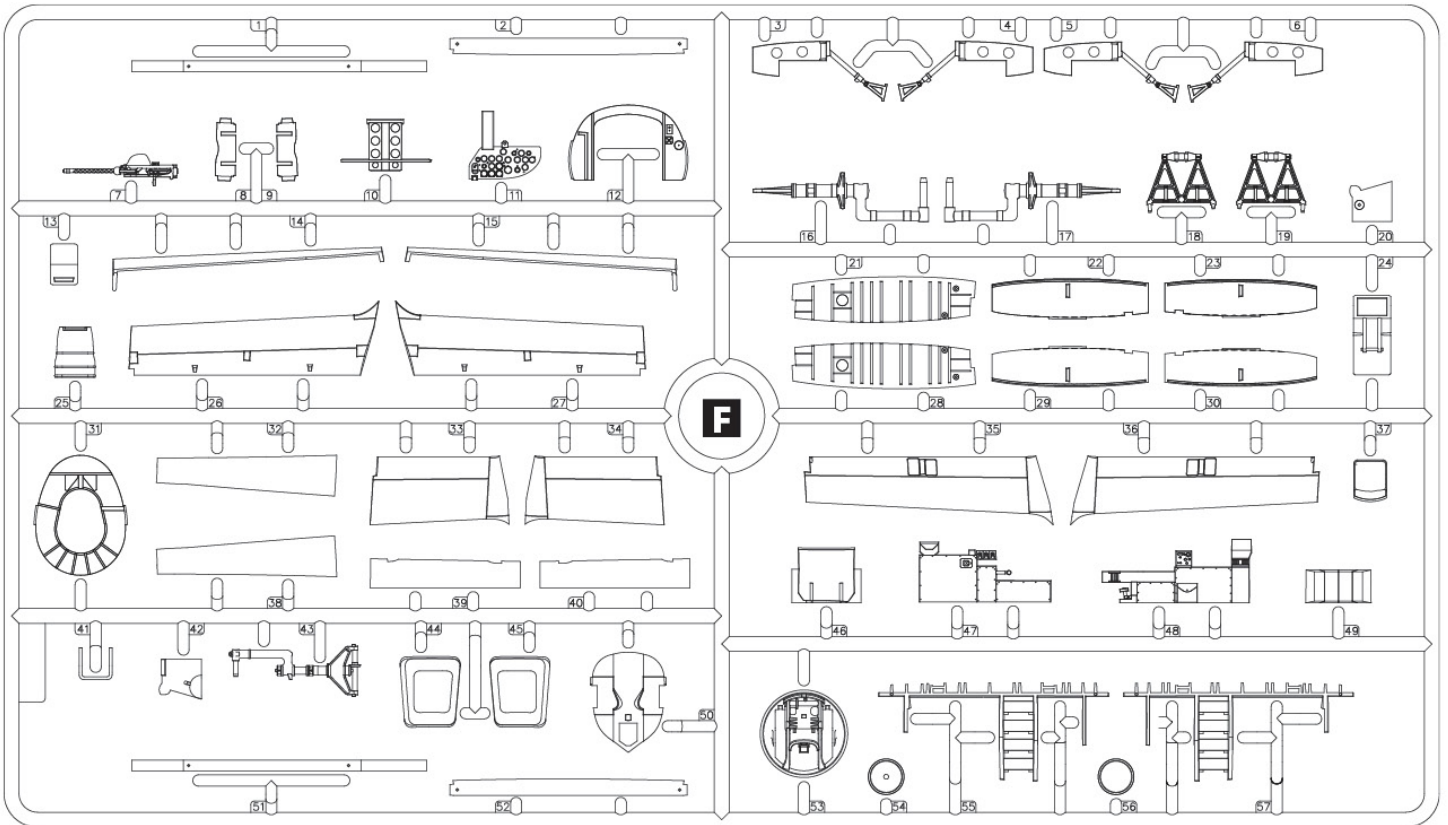
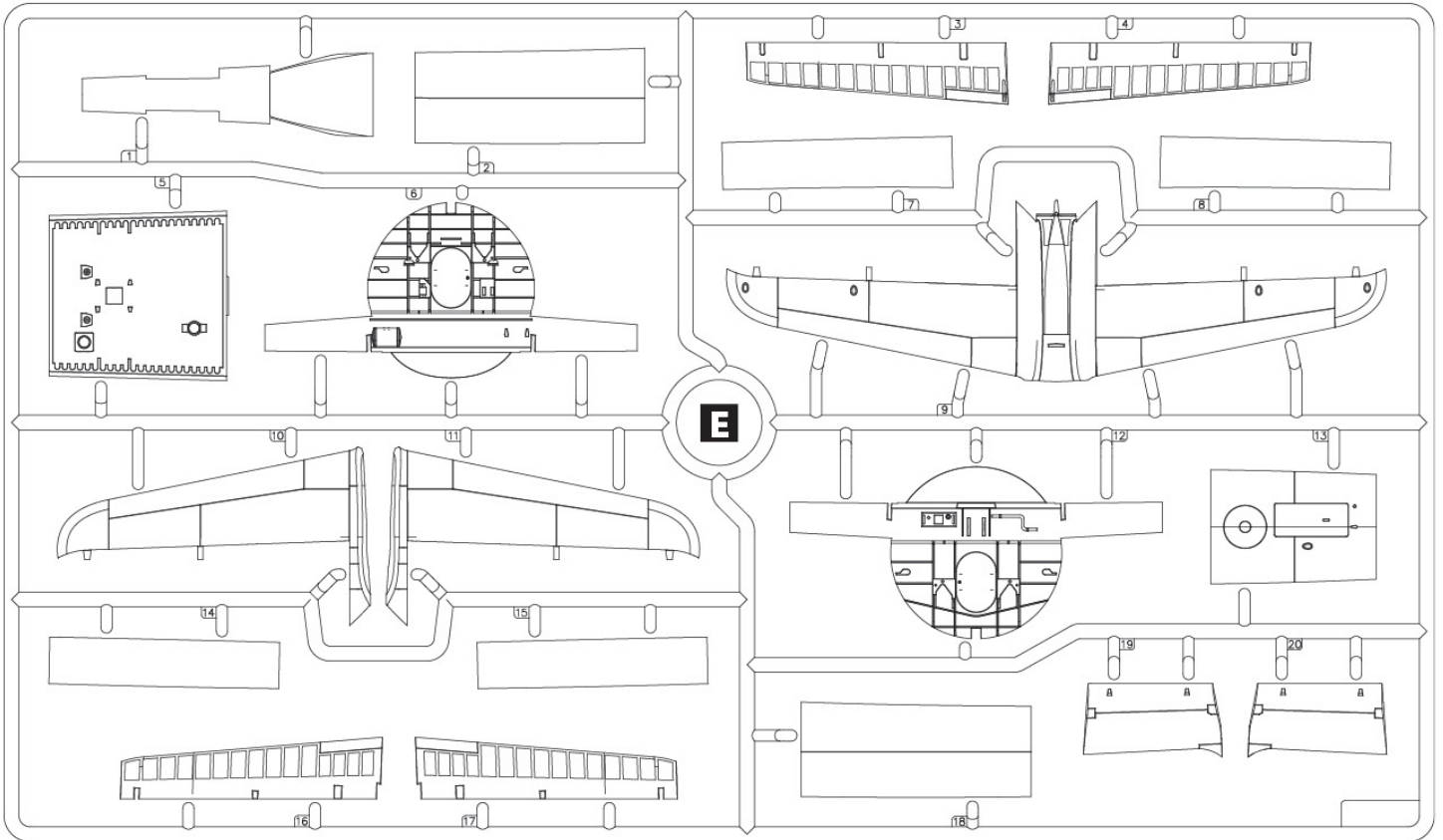

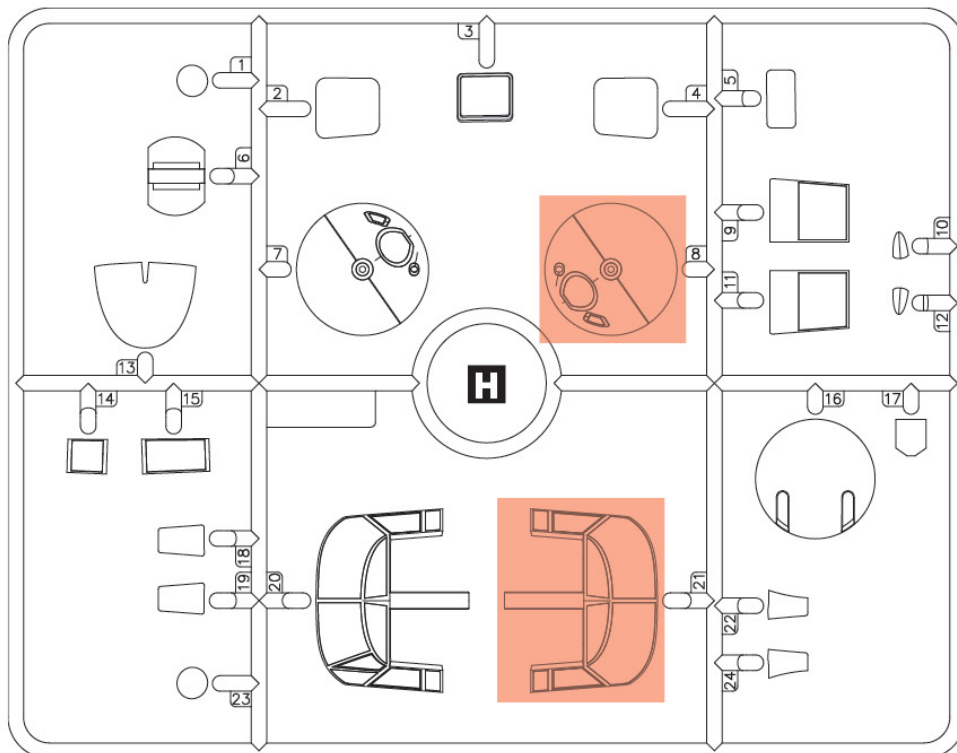
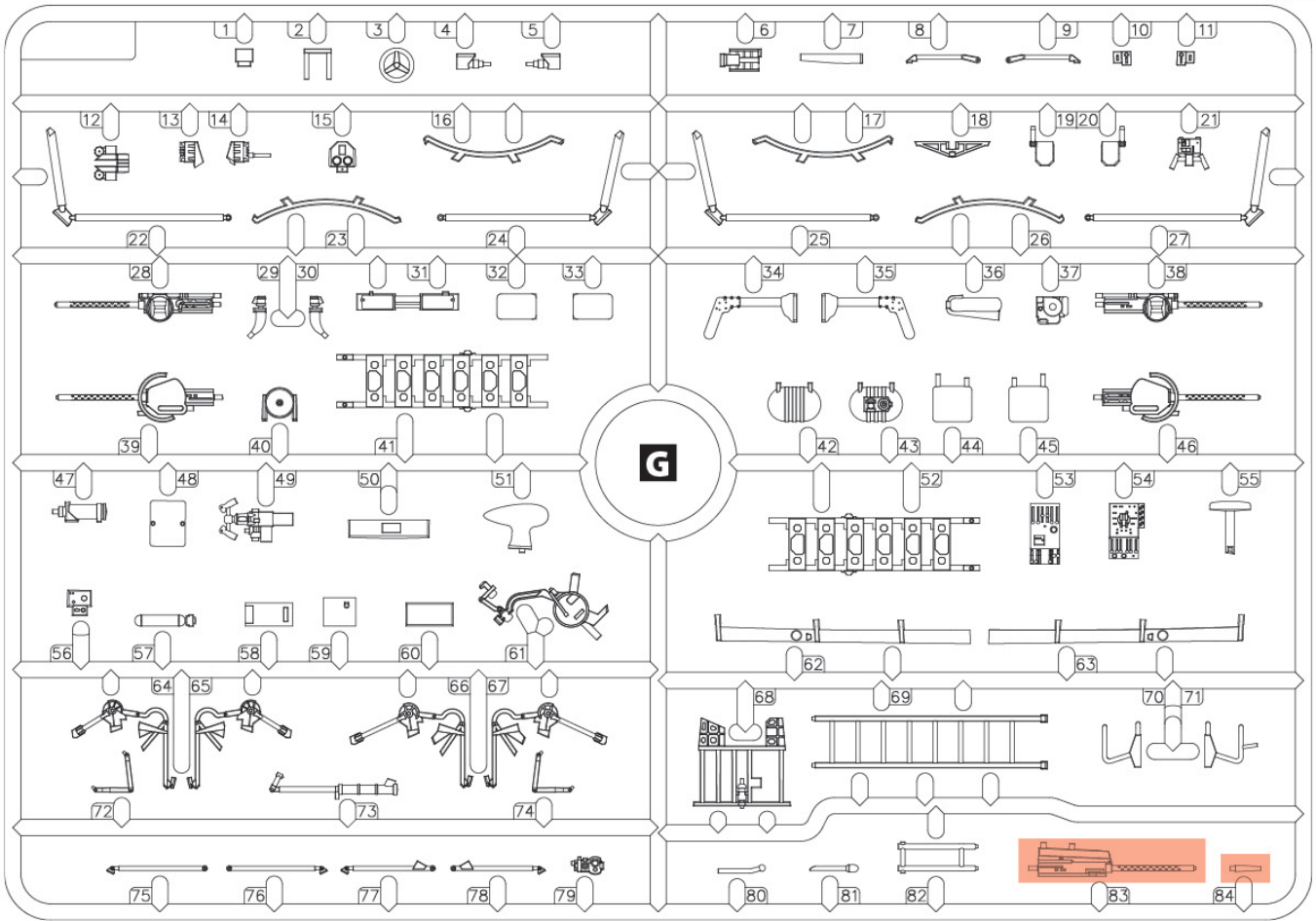

N УСІ ДЕТАЛІ, ОКРІМ
 ПОЗНАЧЕНИХ ОКРЕМО
 ALL DETAILS EXCEPT
 MARKED SEPARATELY

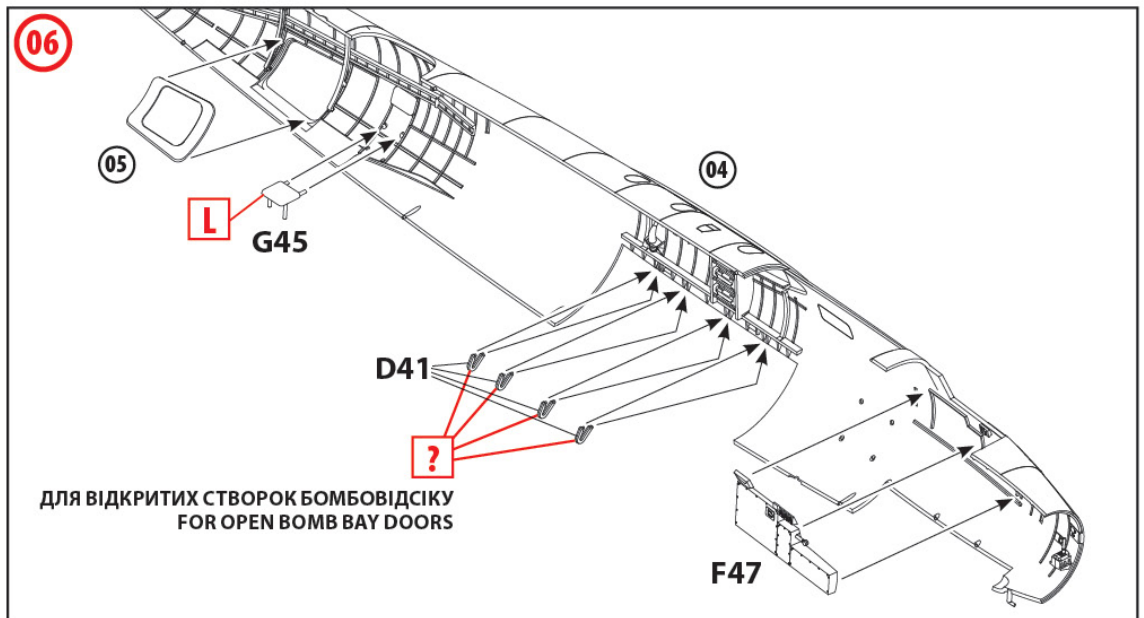
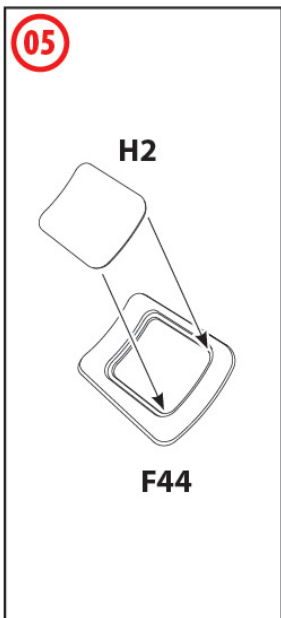
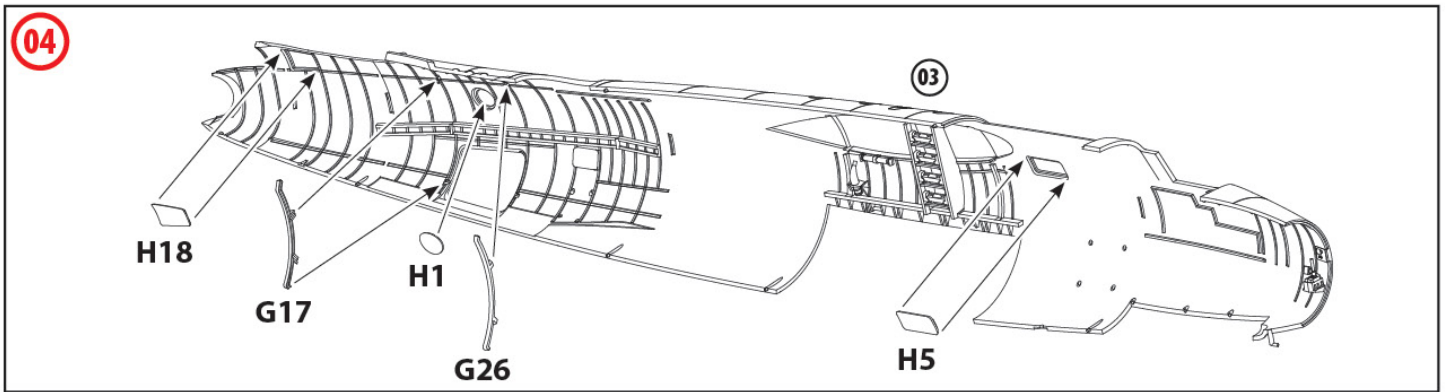
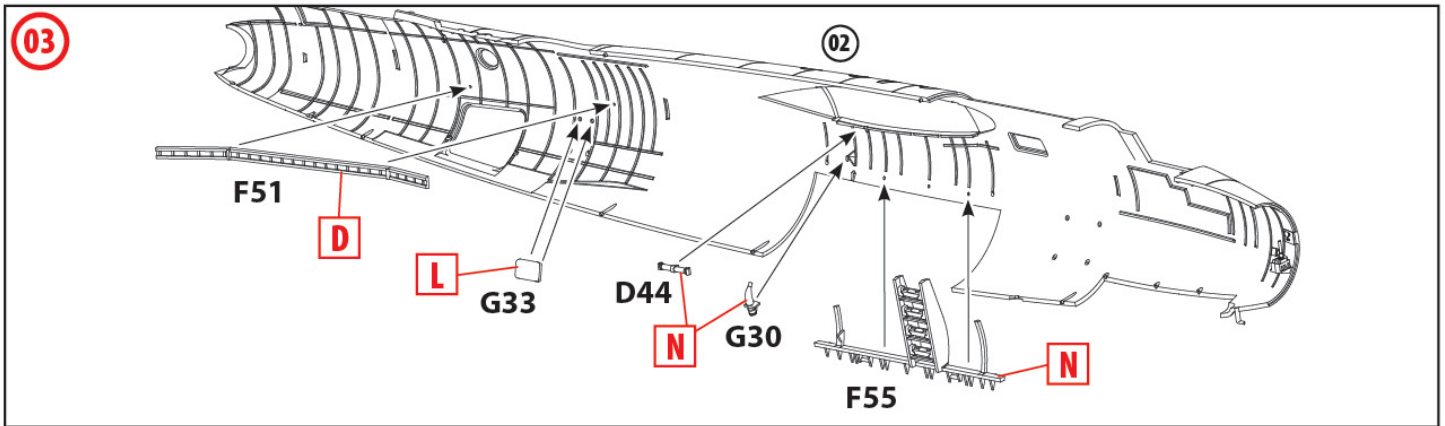
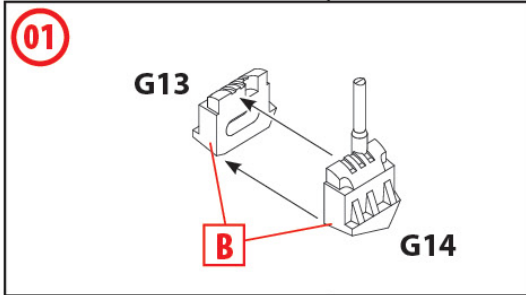
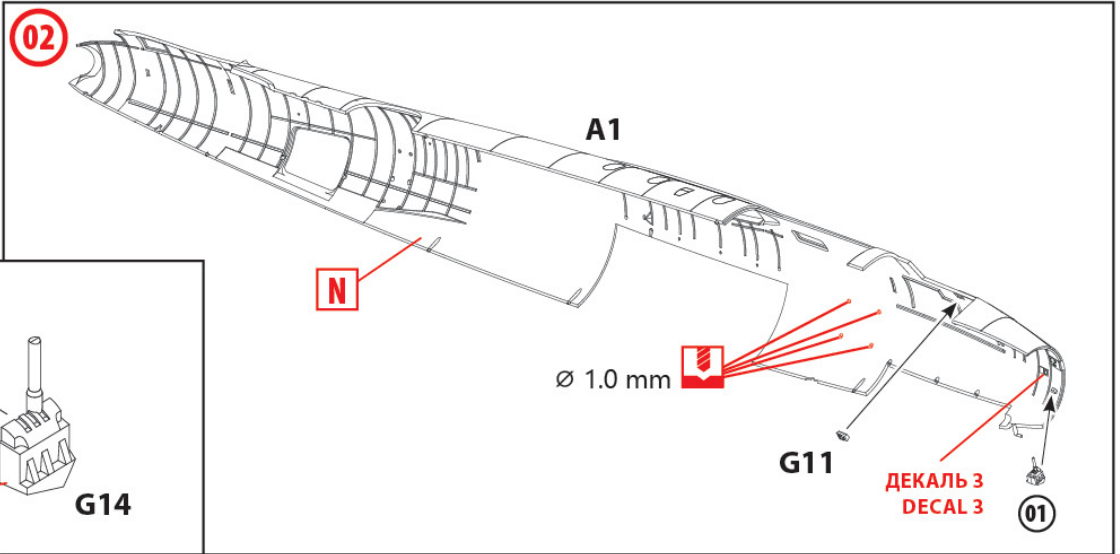

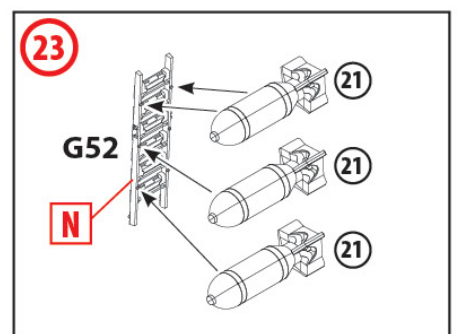
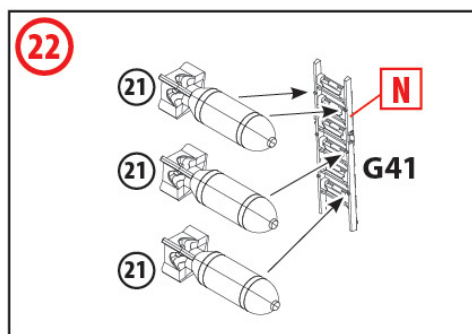
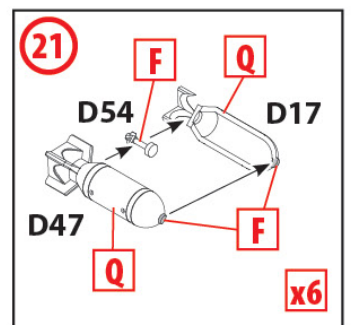
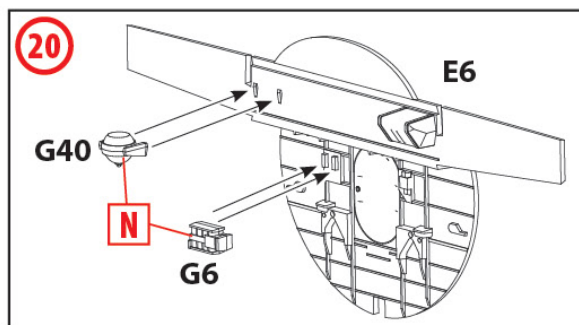
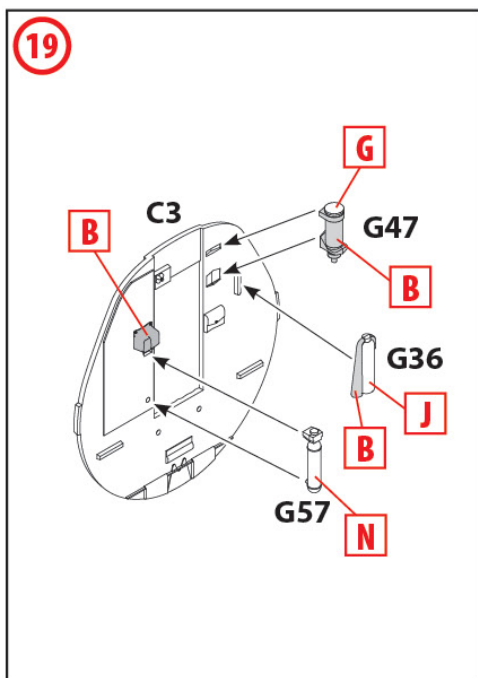
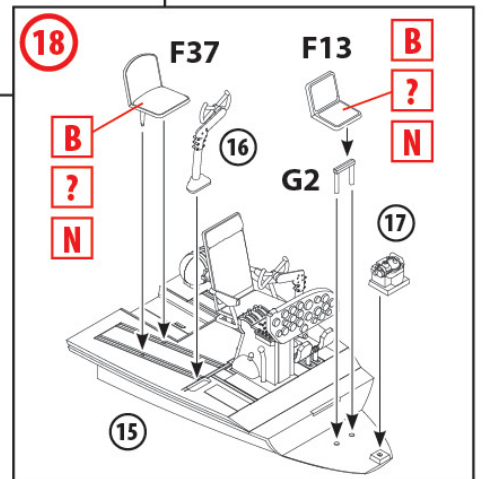
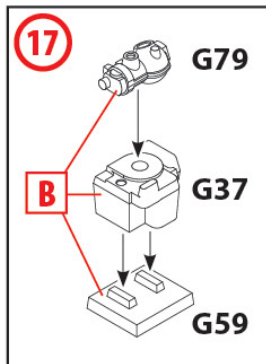
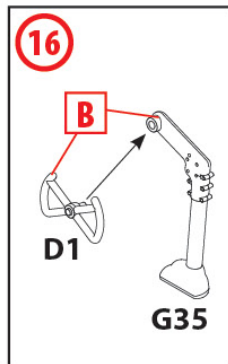
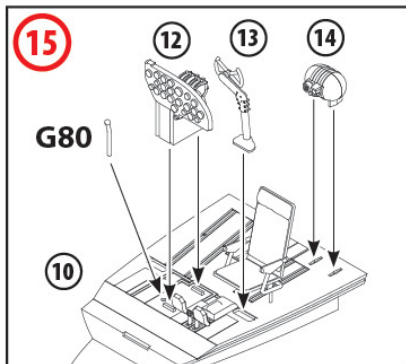
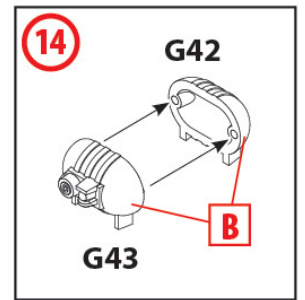
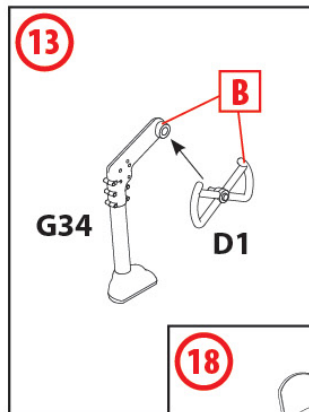
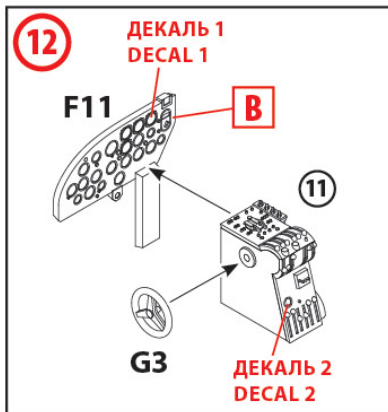
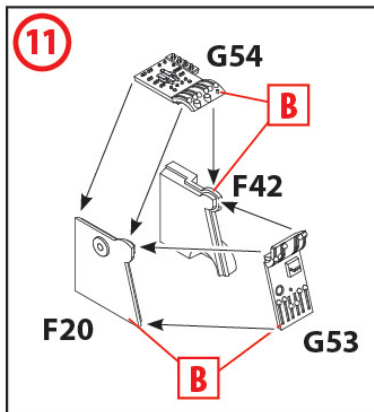
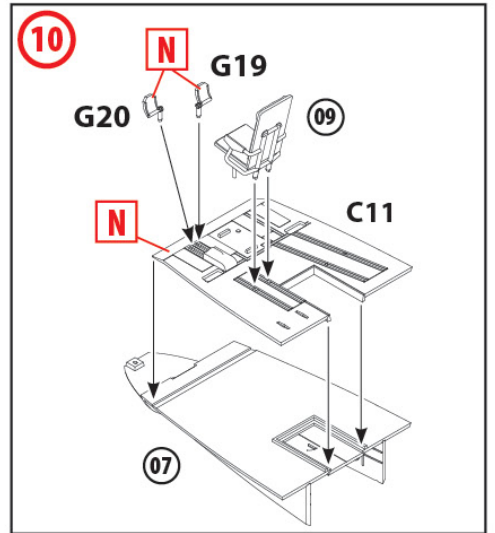
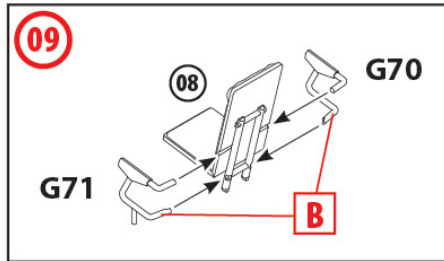
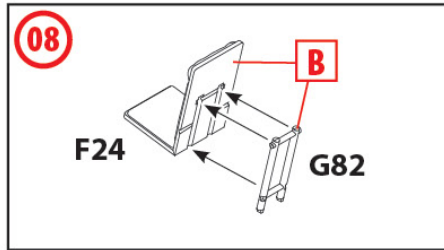
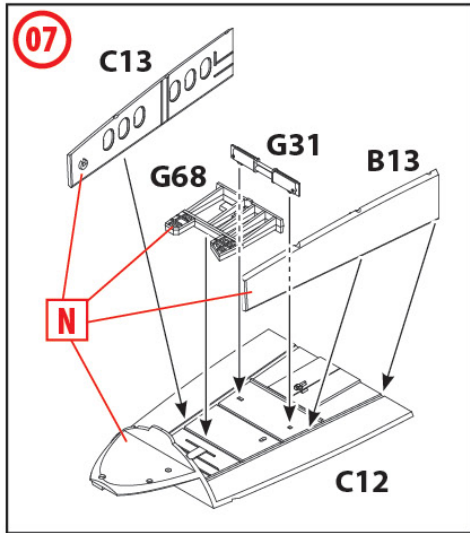

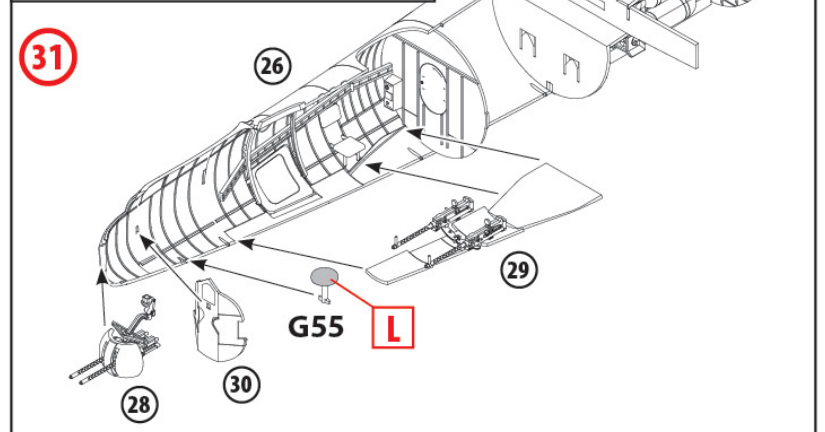
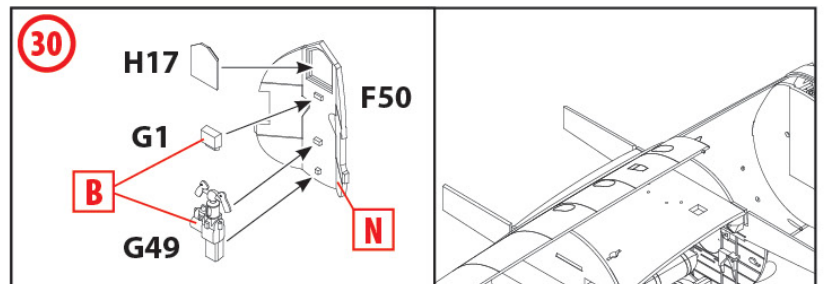
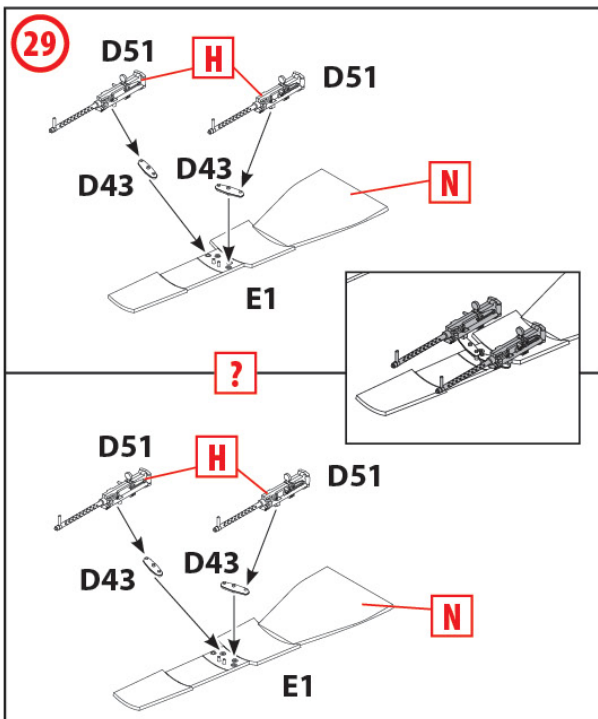
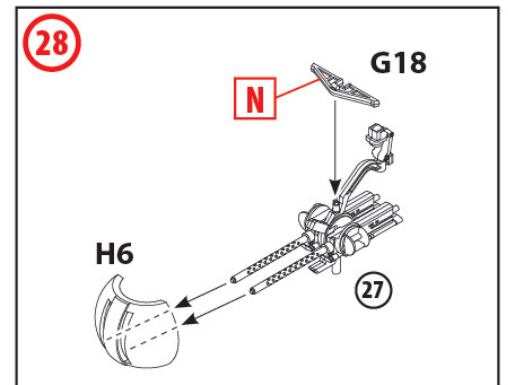
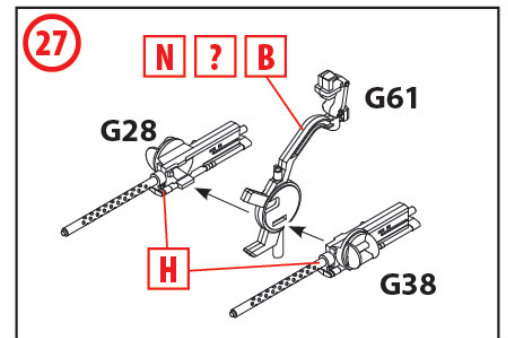
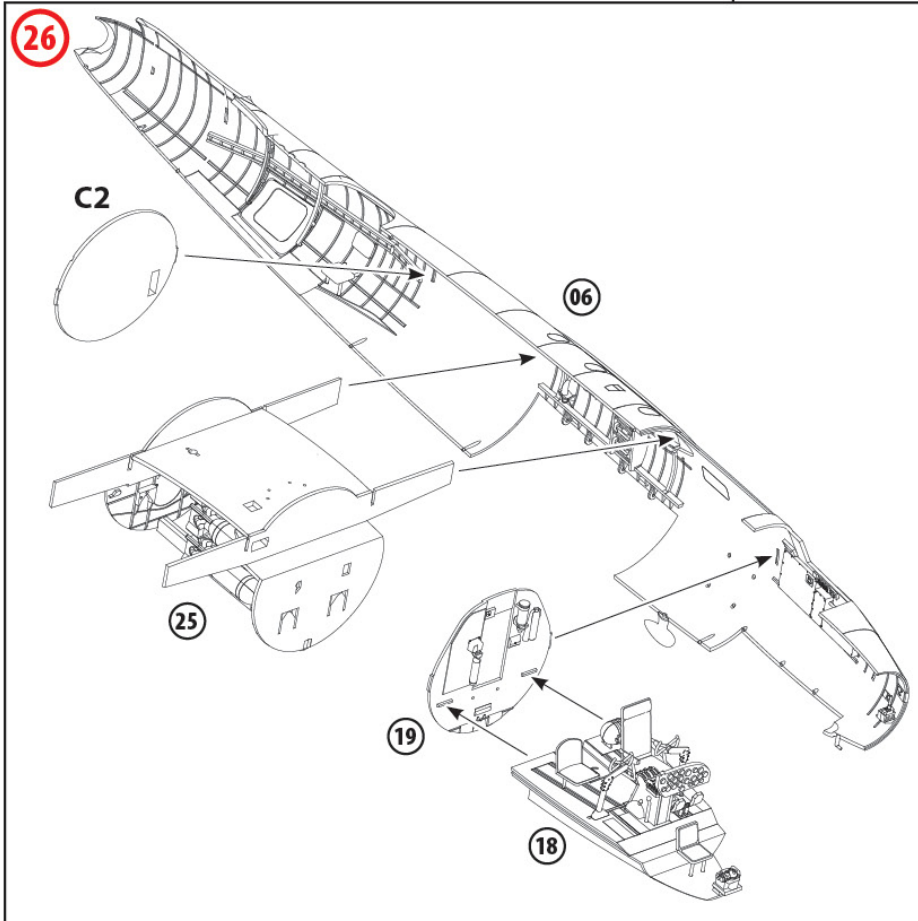
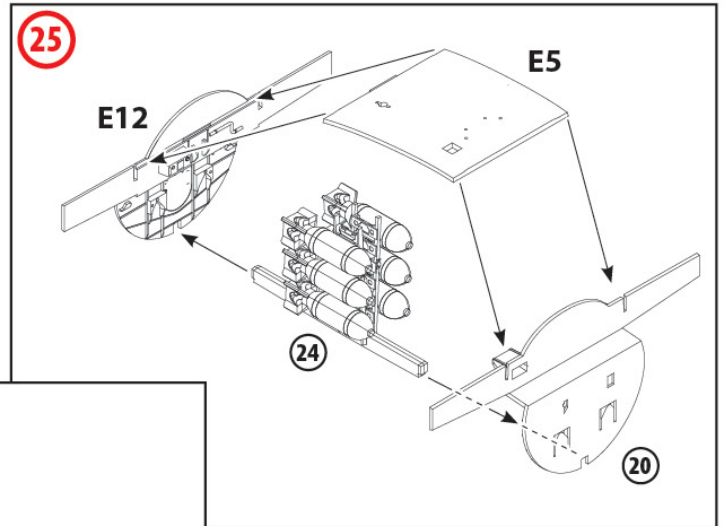
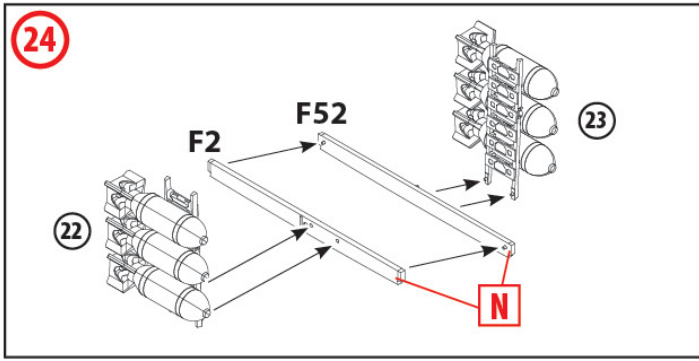

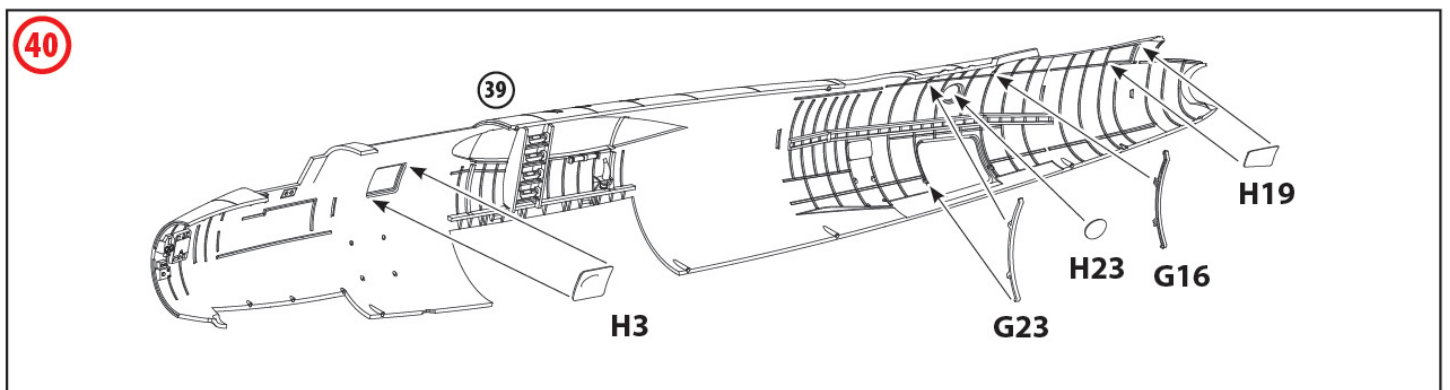
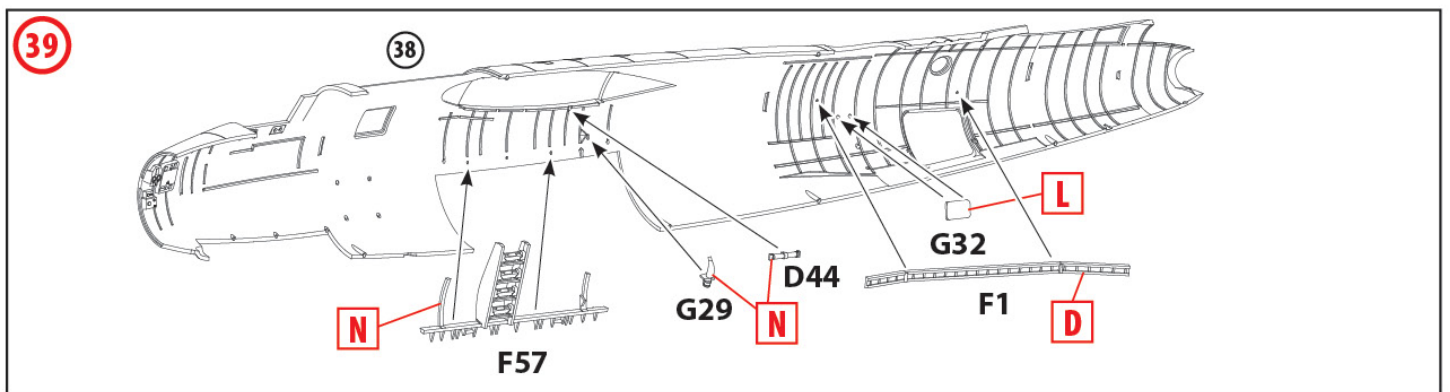
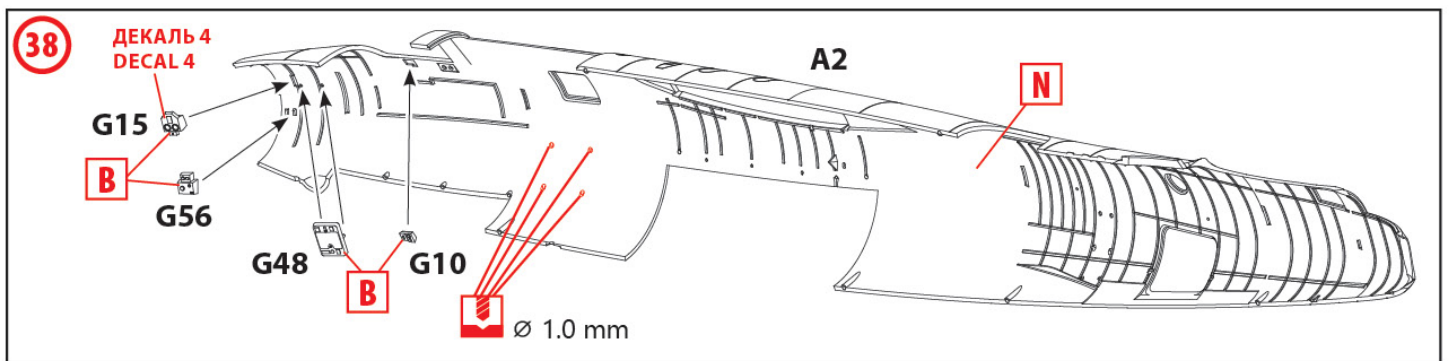
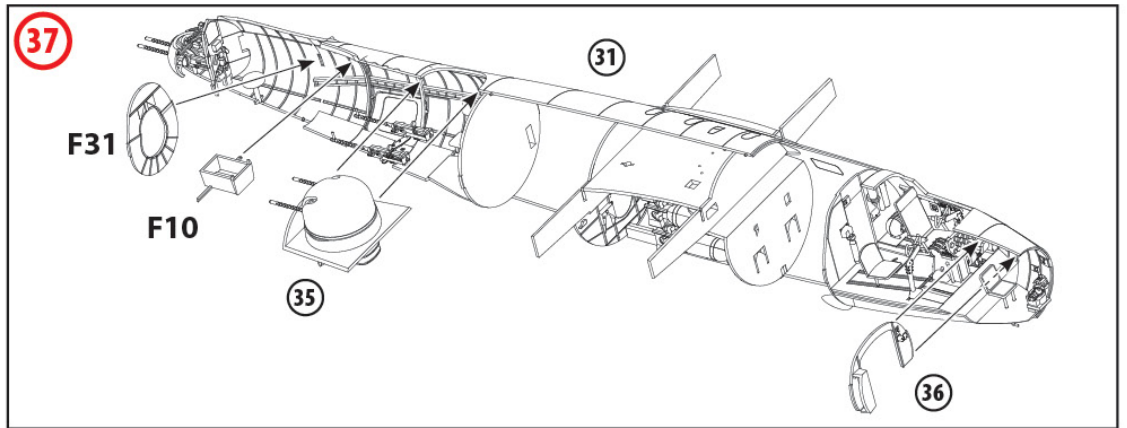
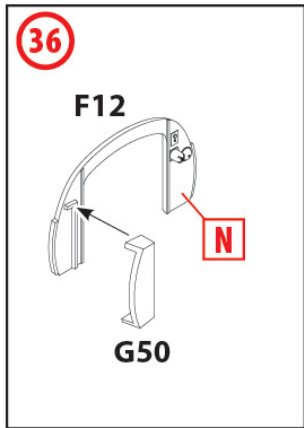
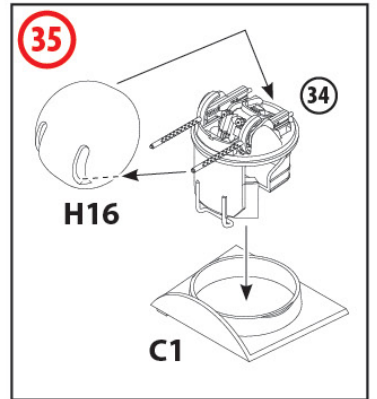
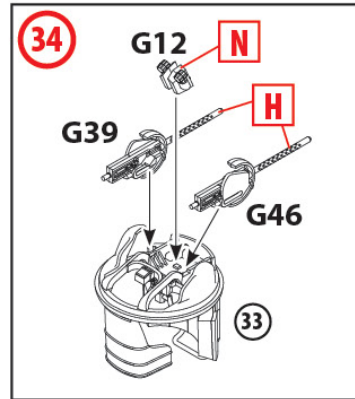
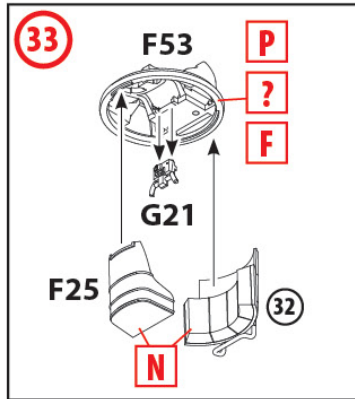
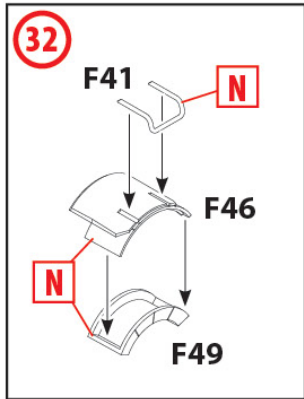

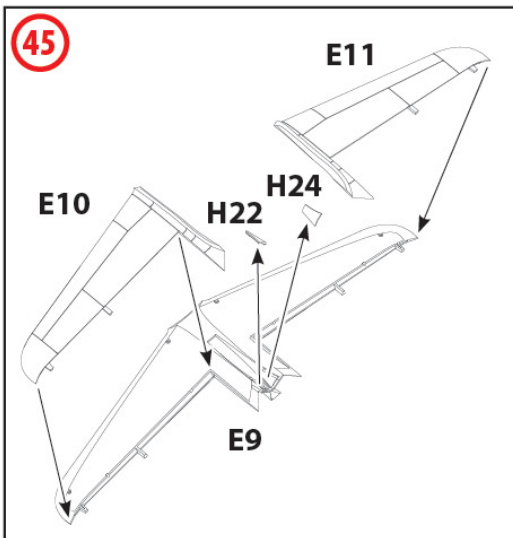
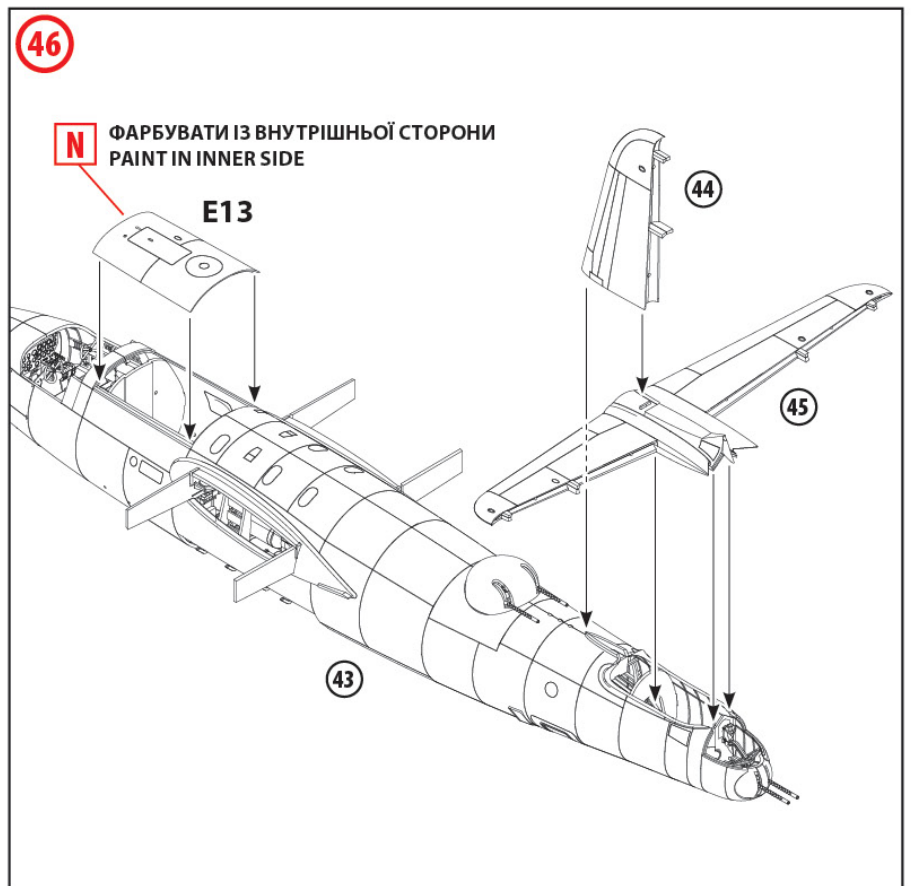
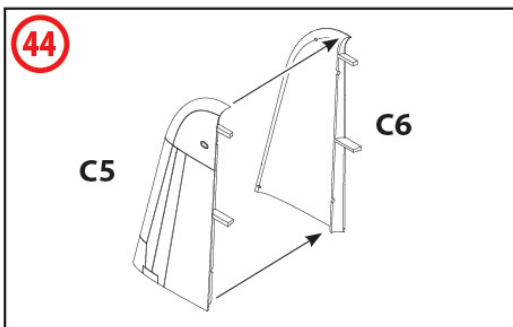
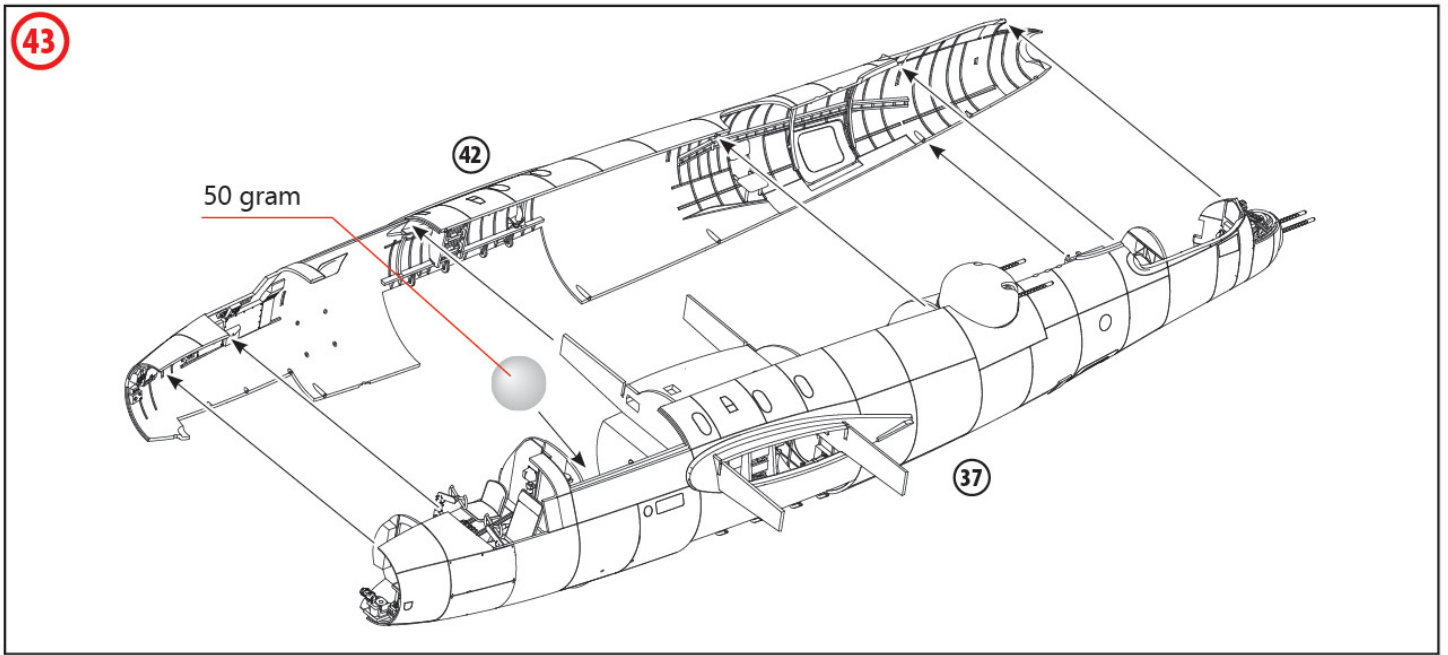
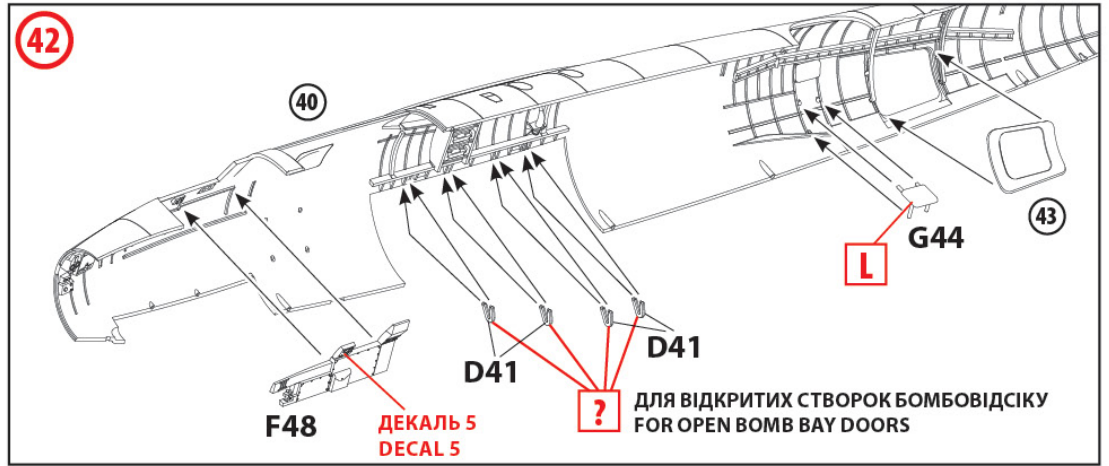
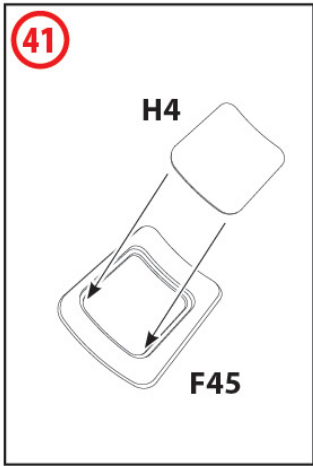

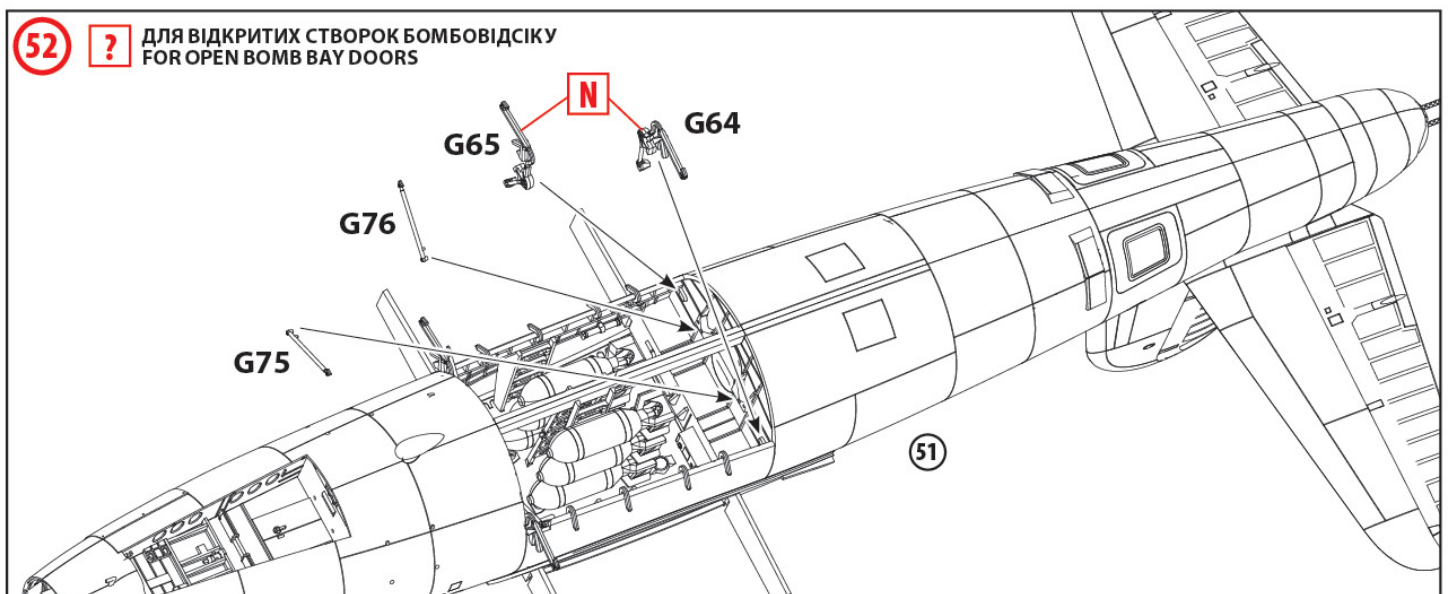
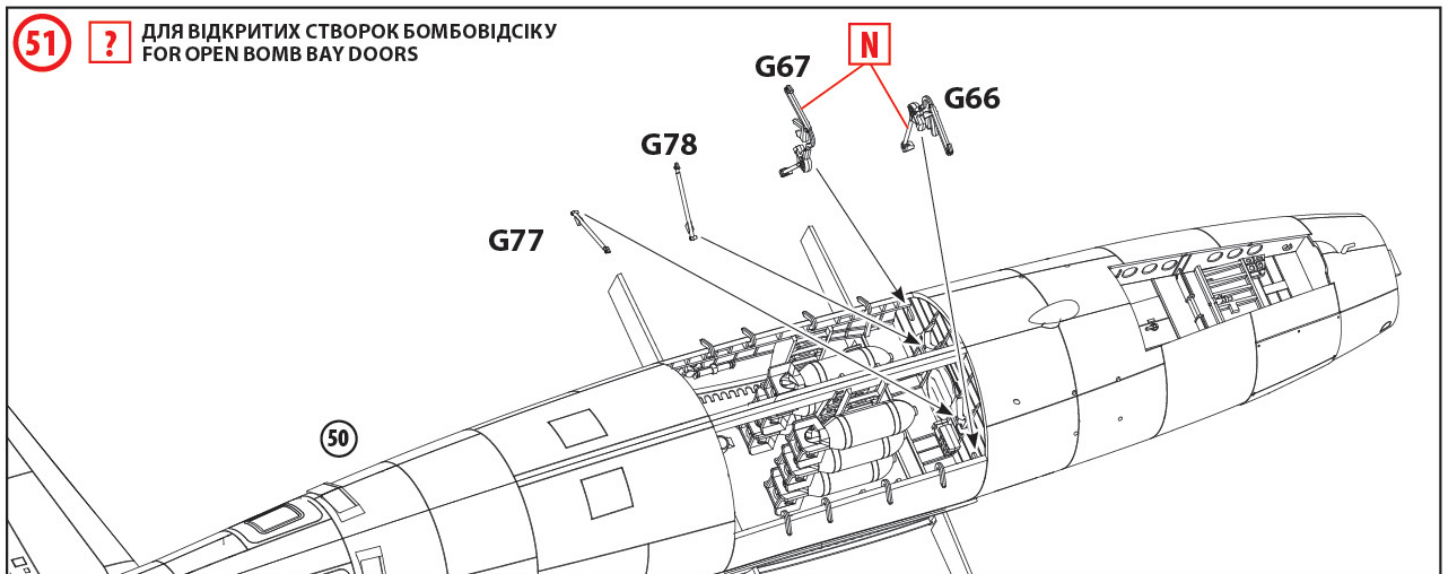
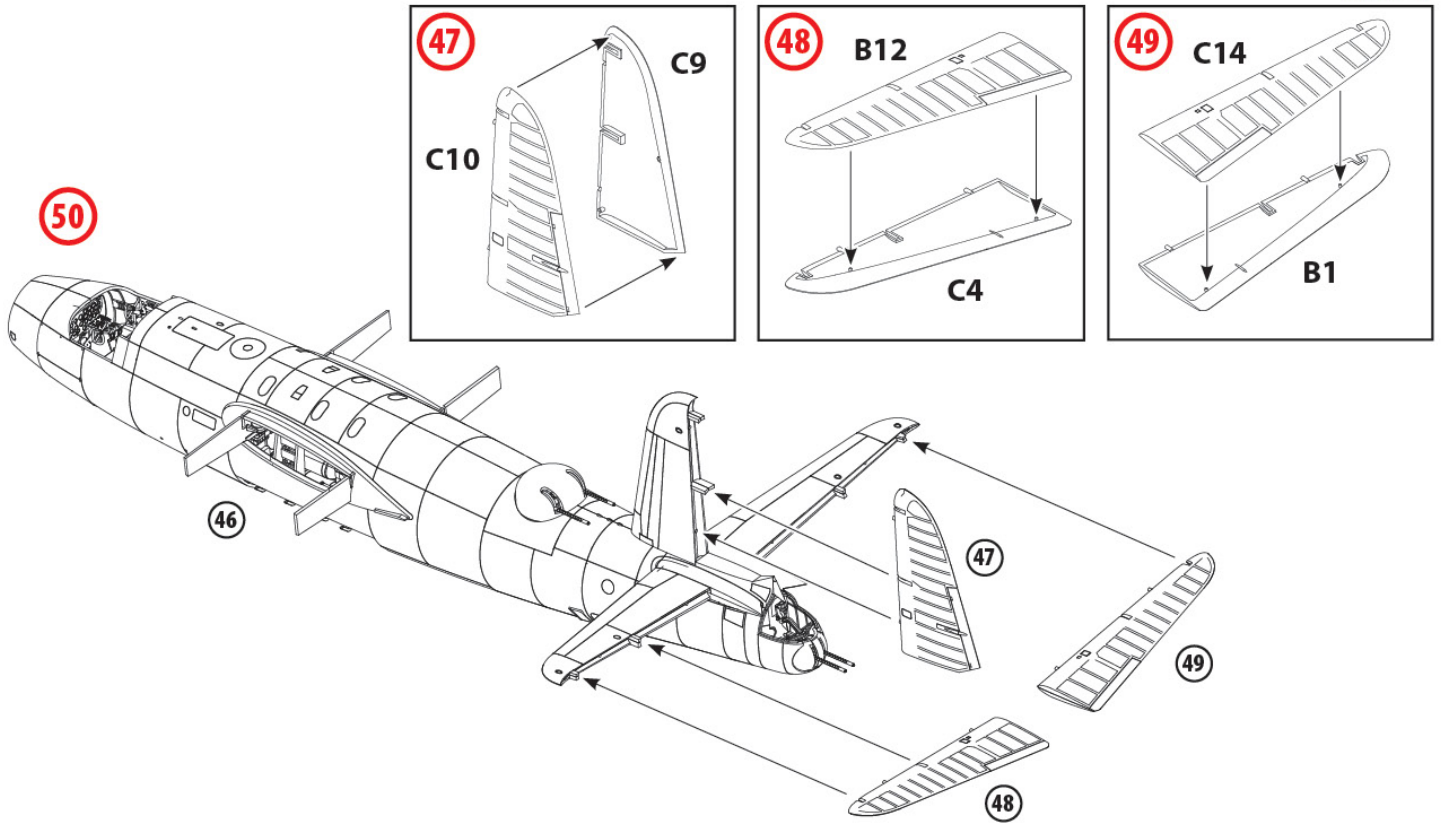

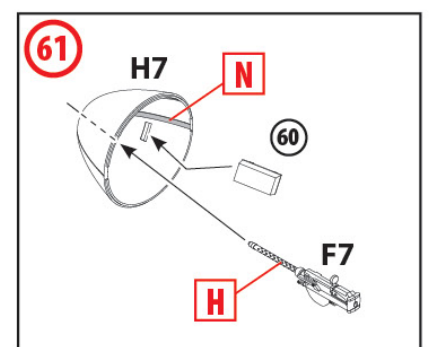
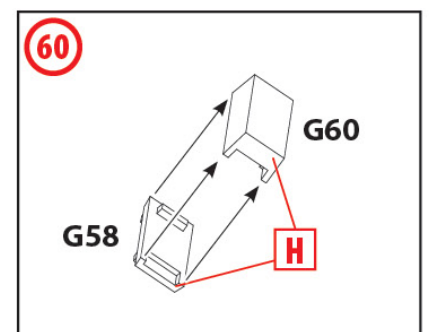
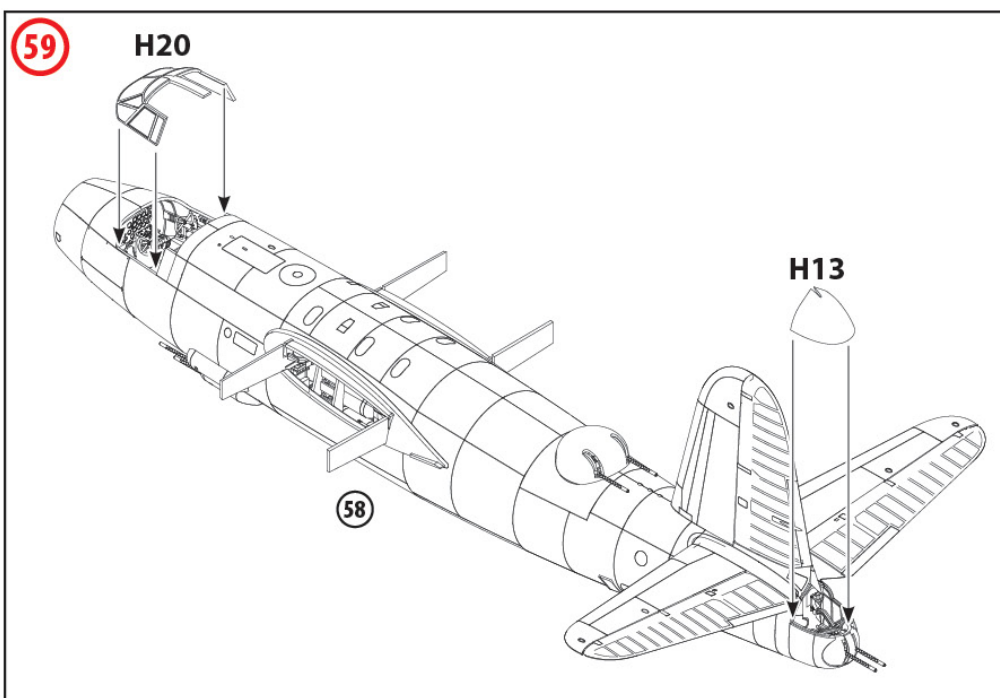
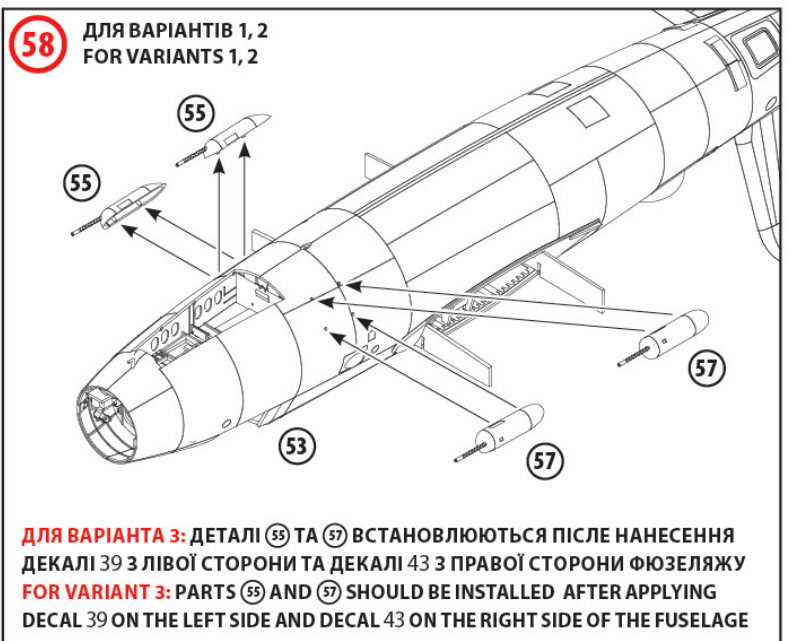
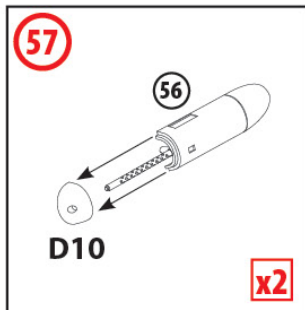
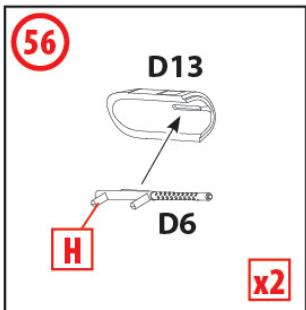
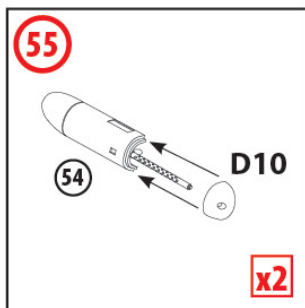
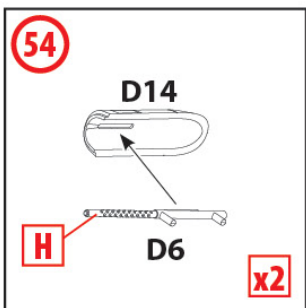
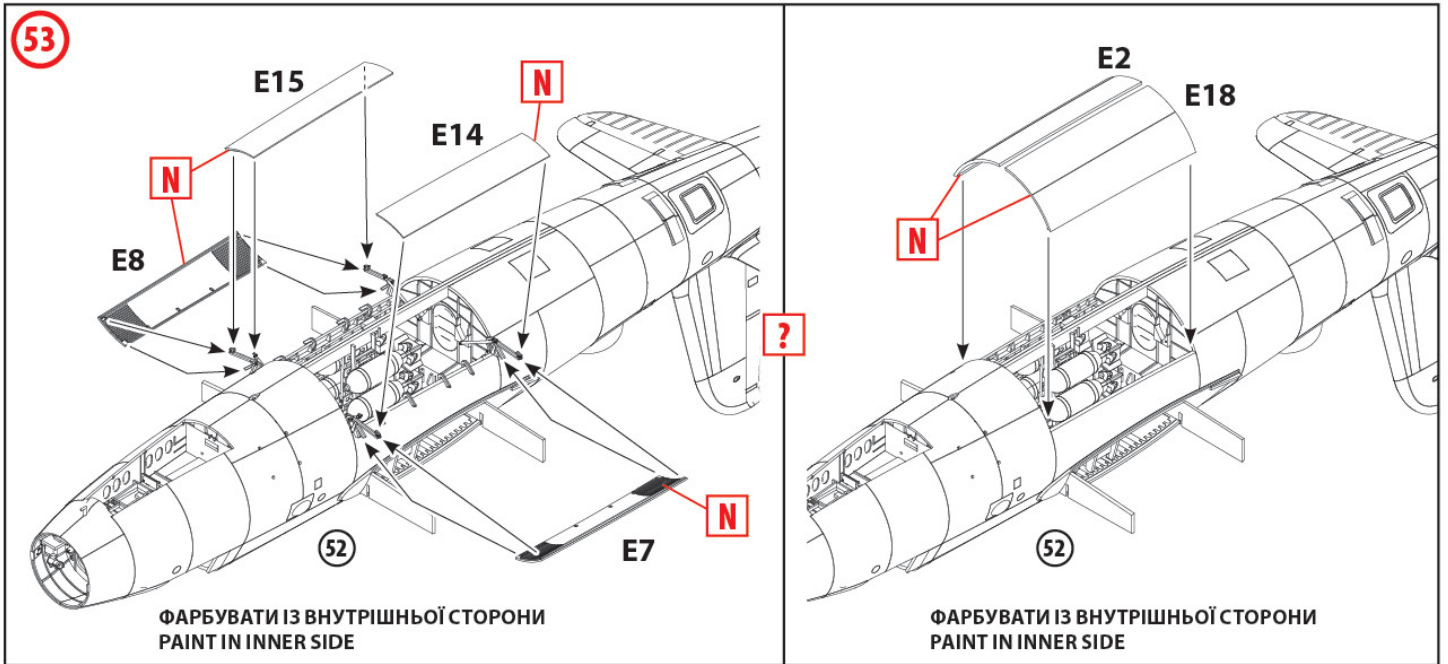

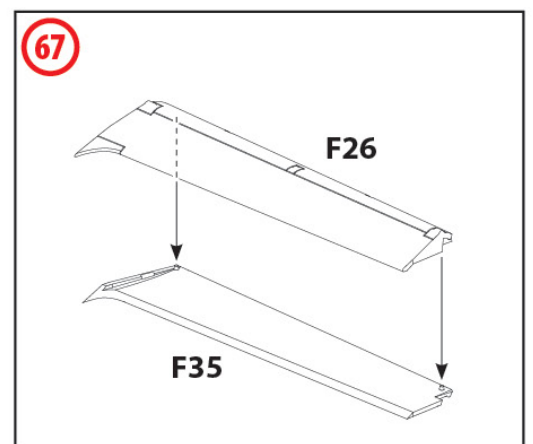
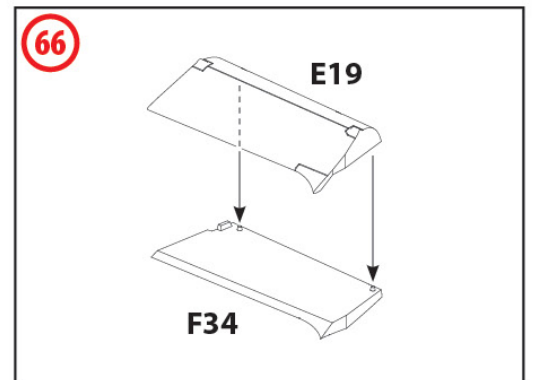
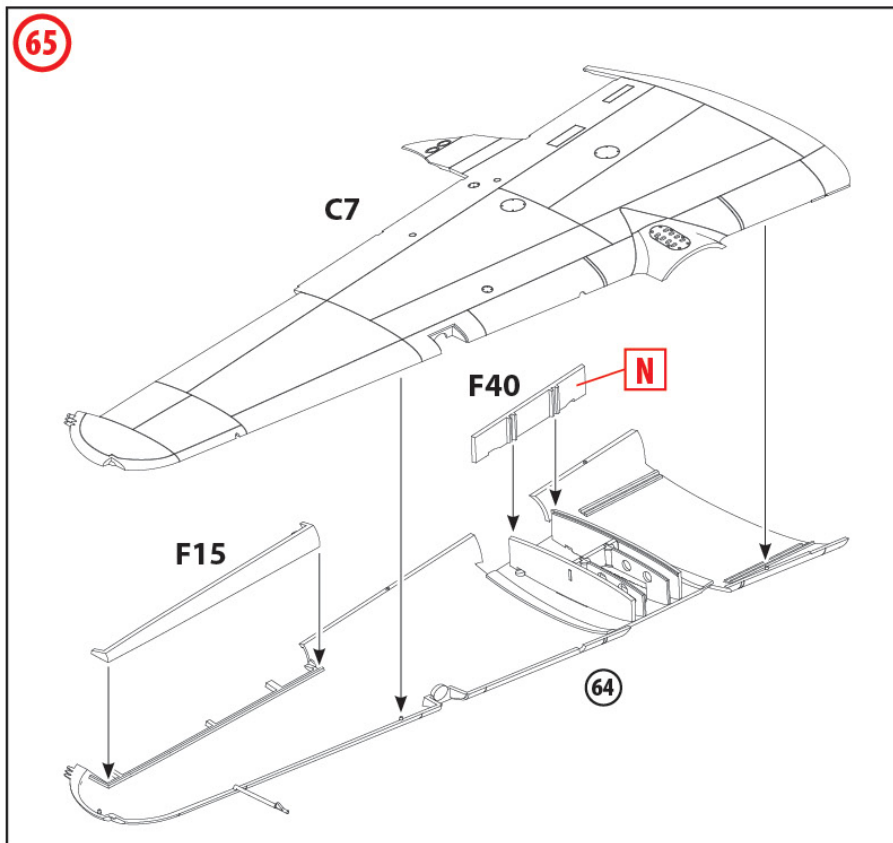
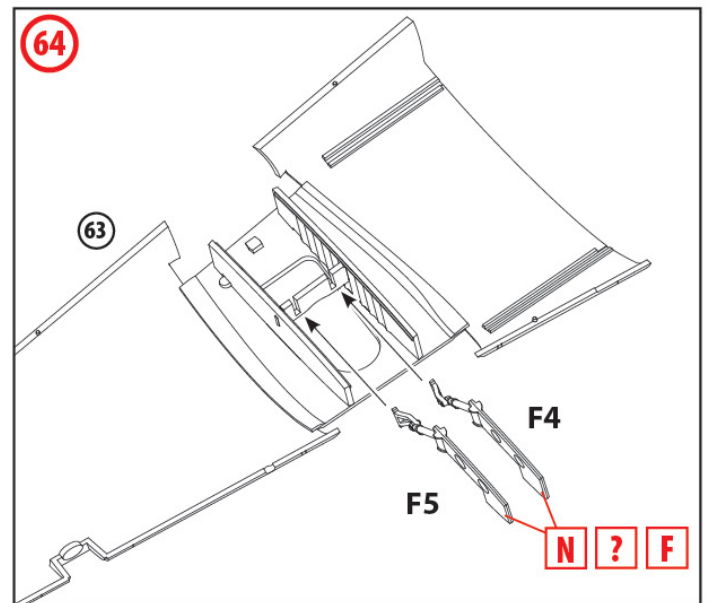
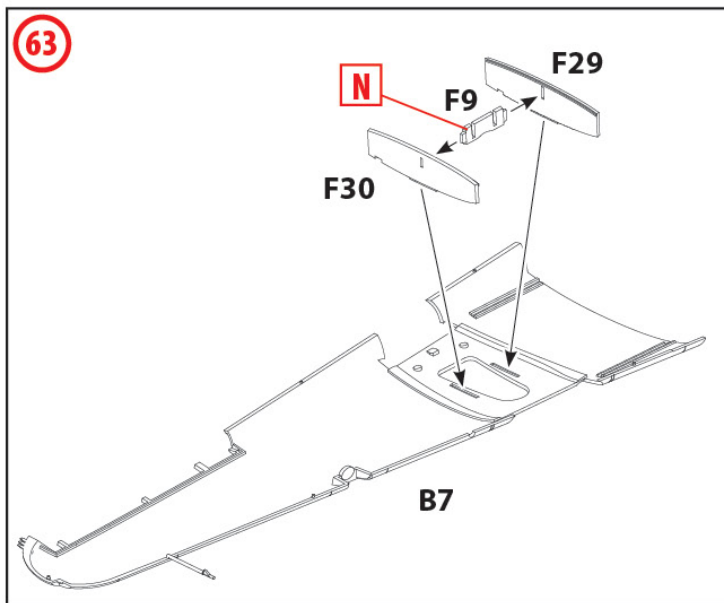
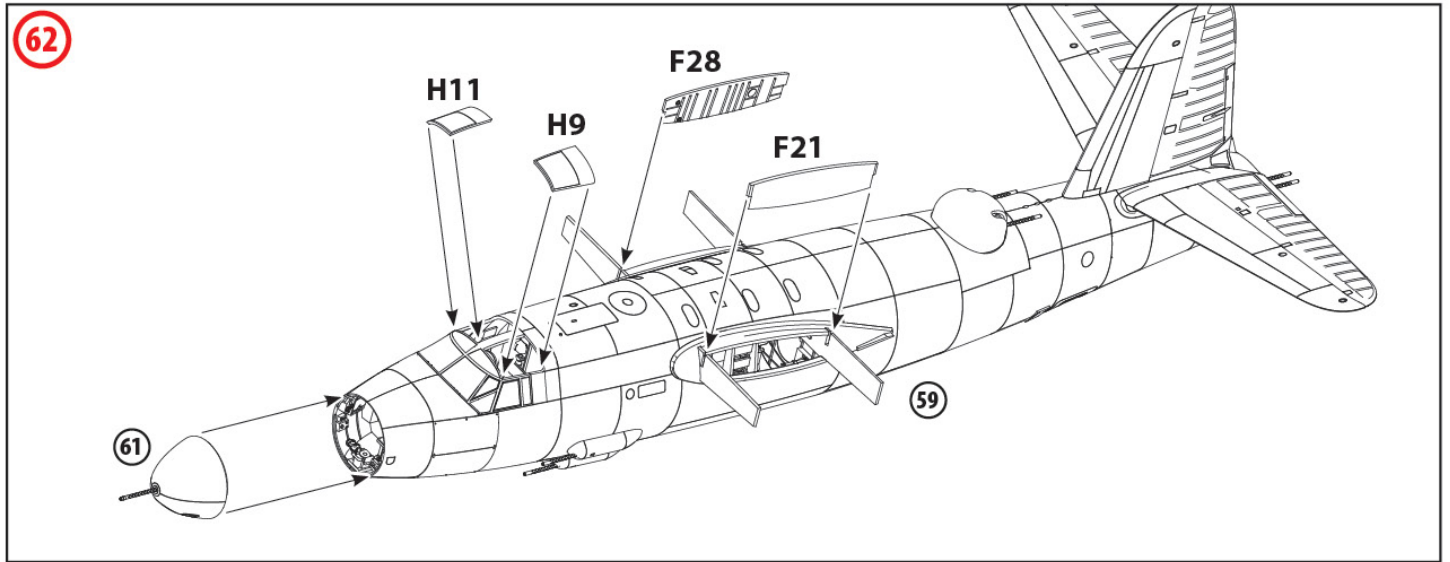

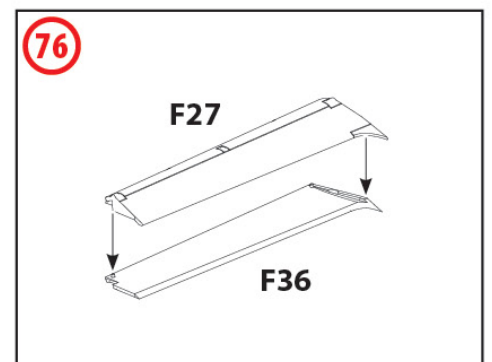
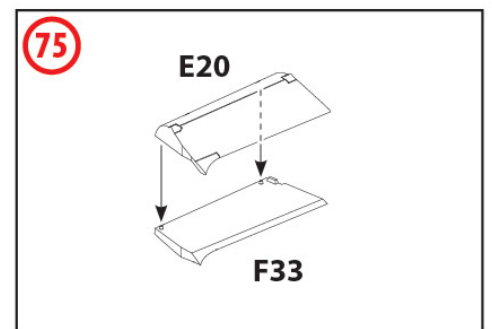
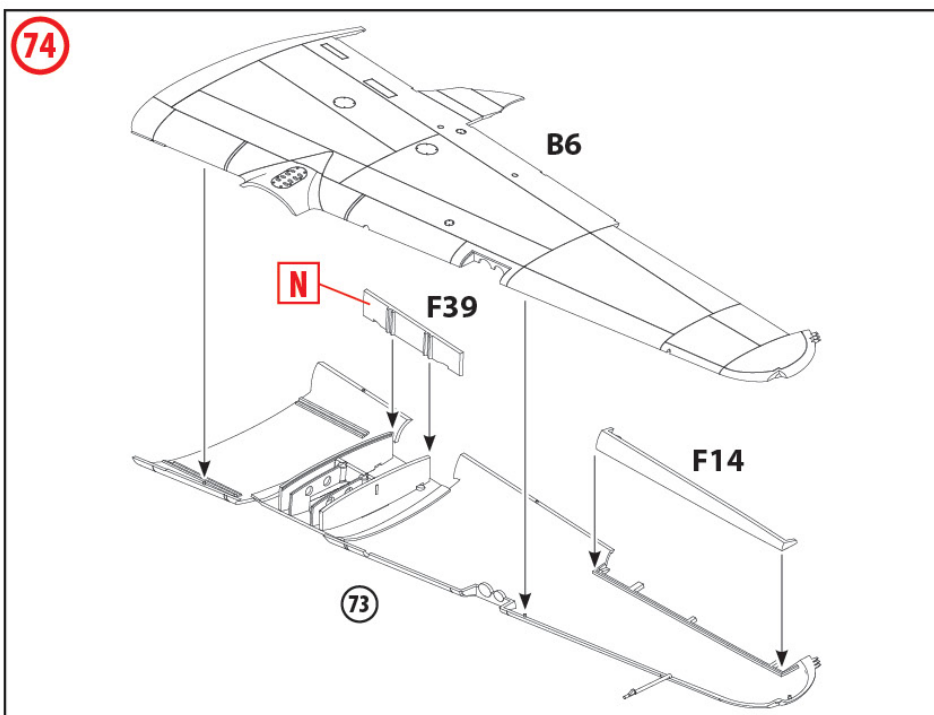
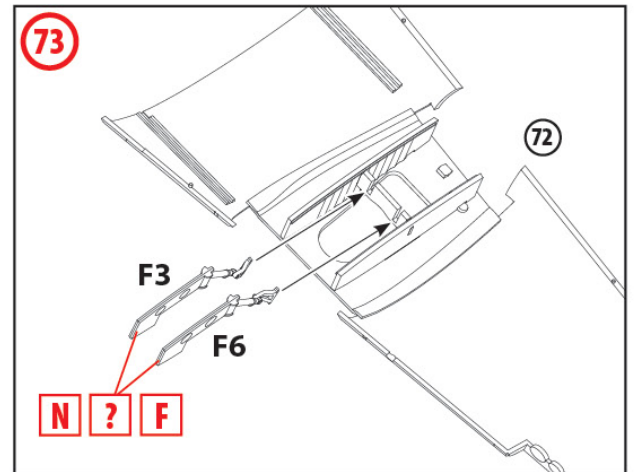
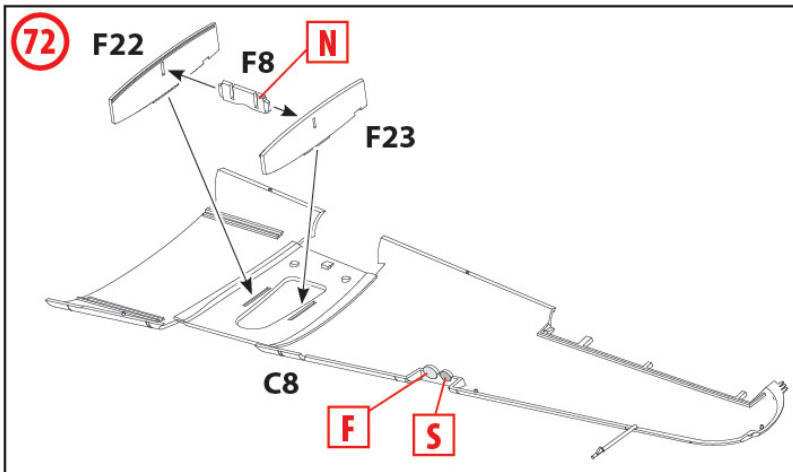
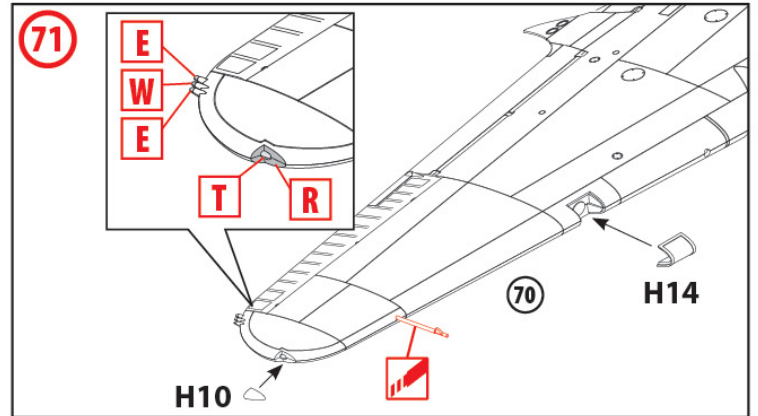
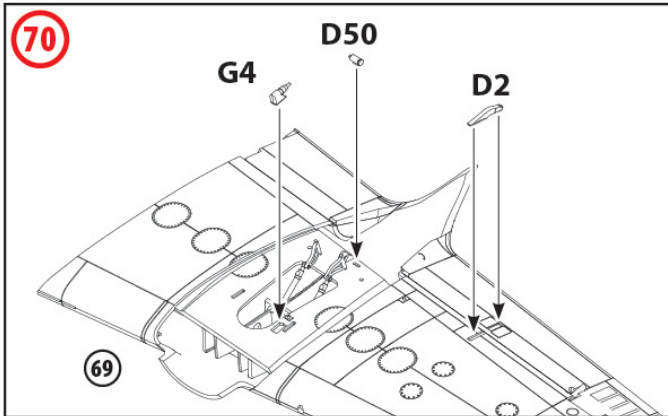
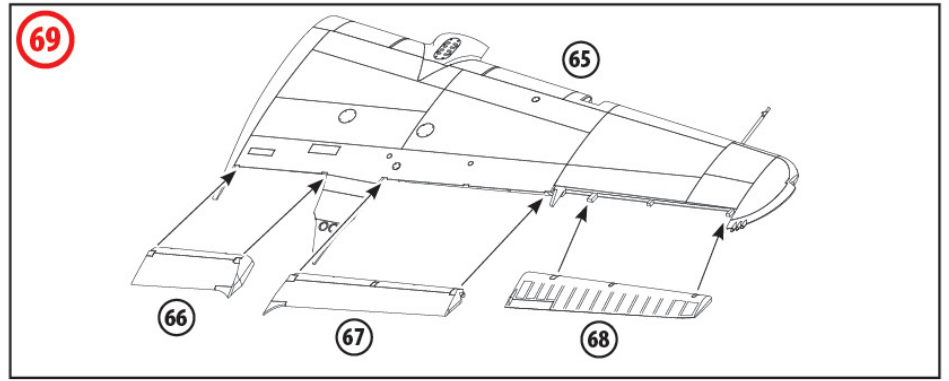
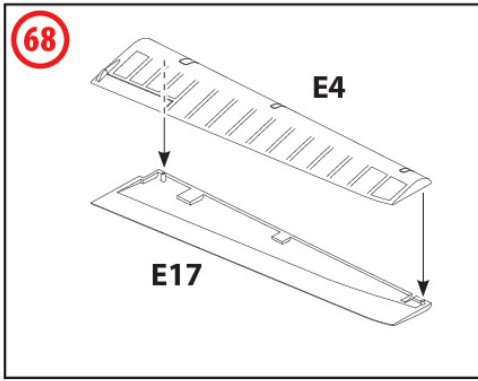

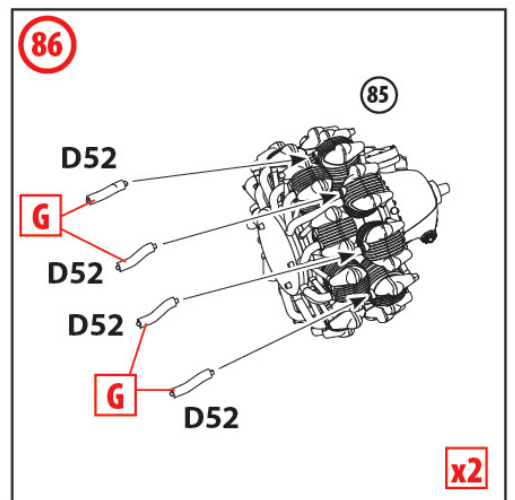
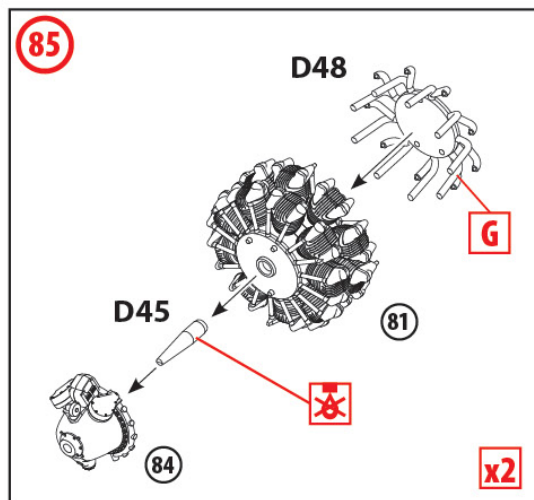
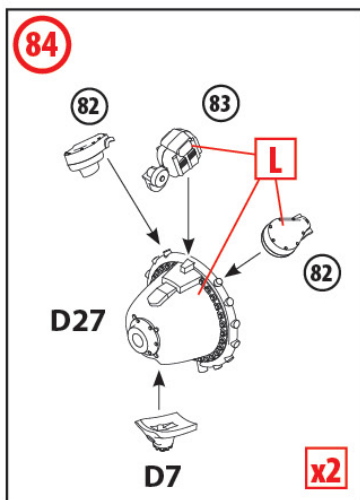
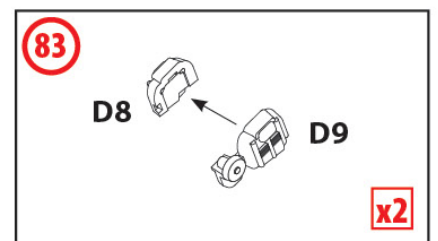
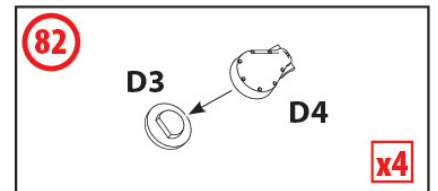
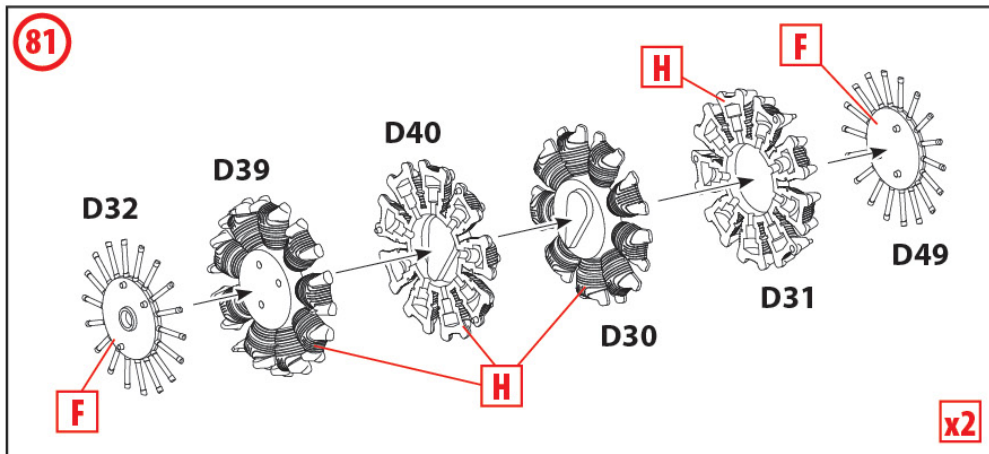
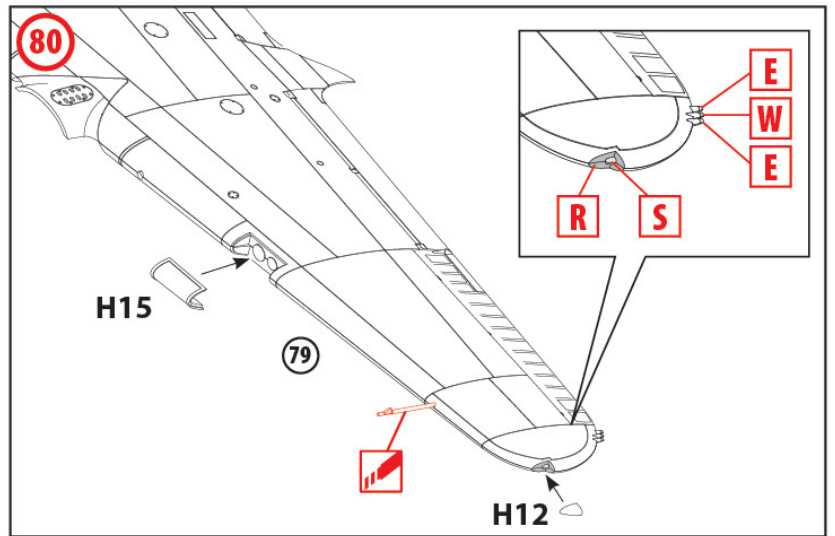
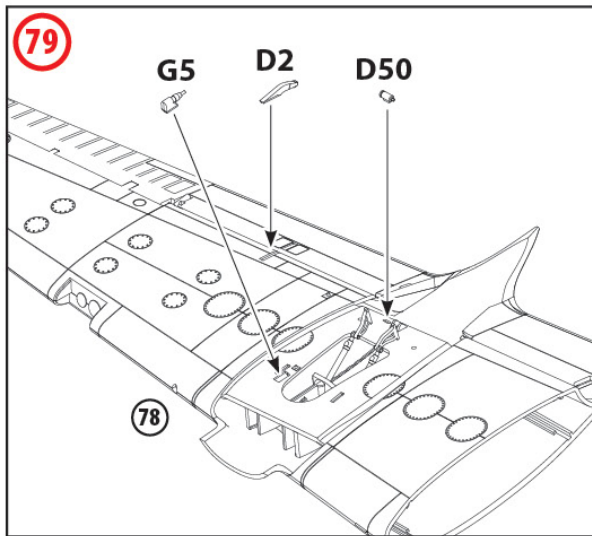
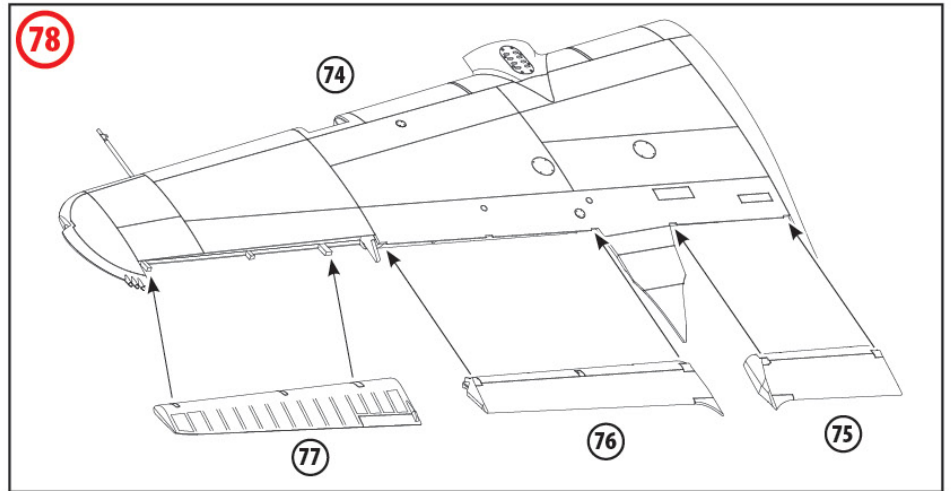
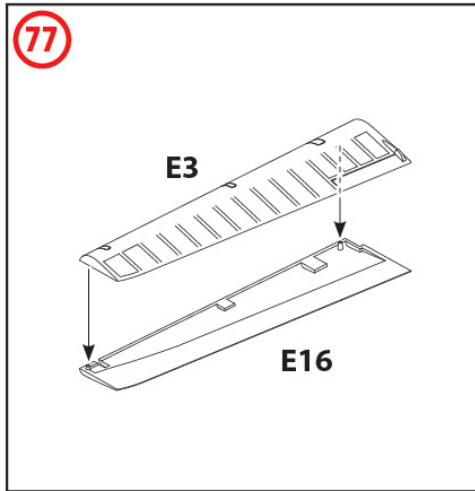

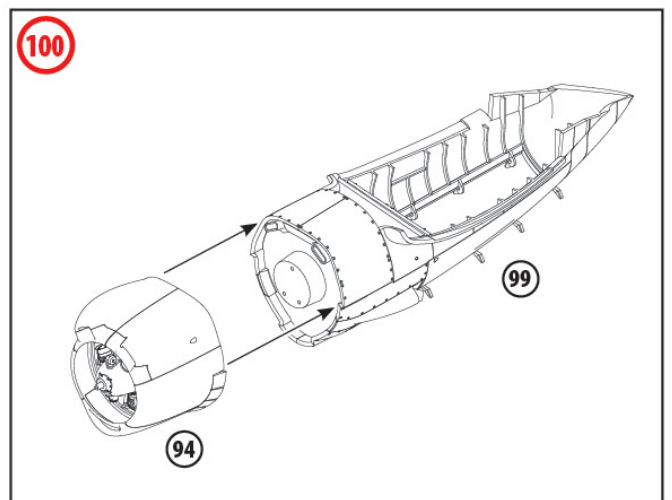
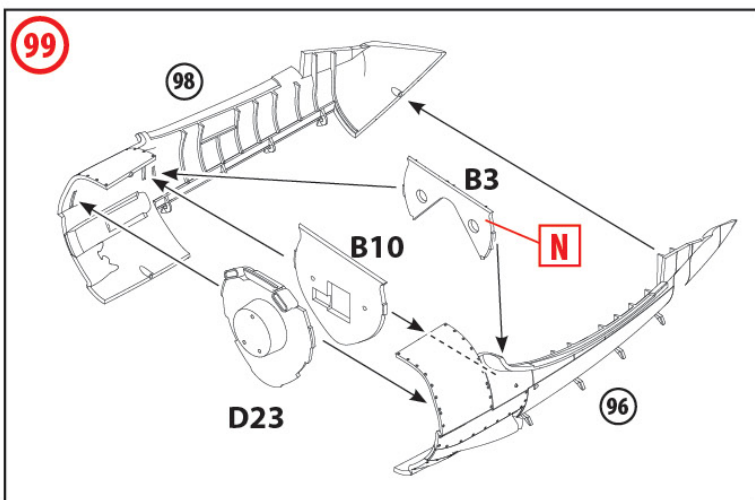
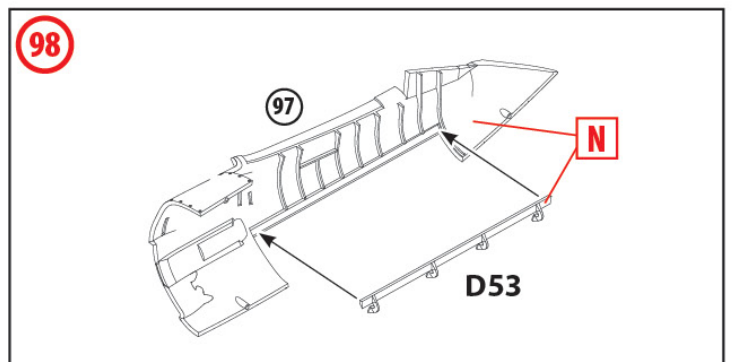
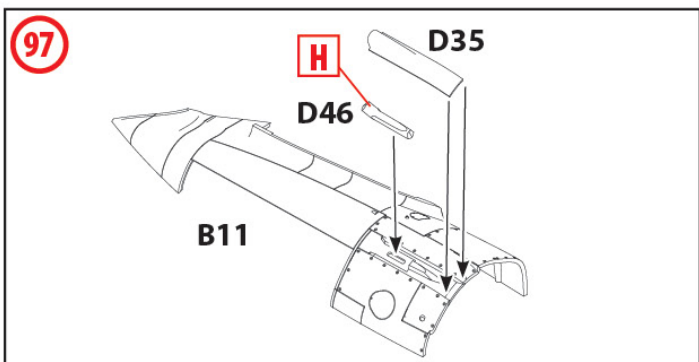
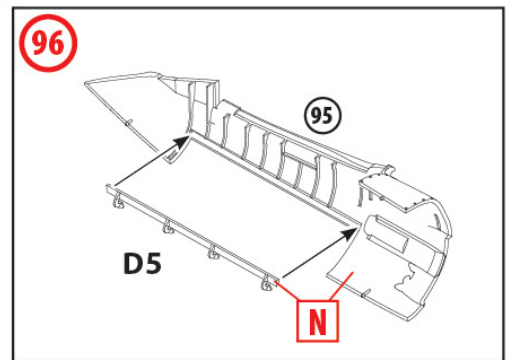
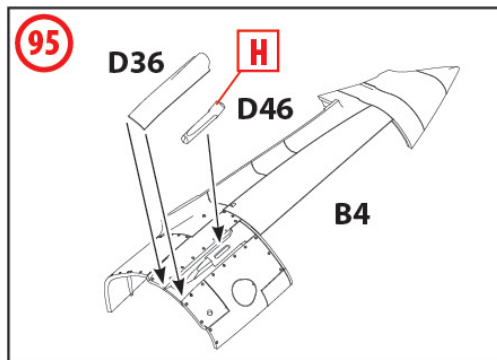
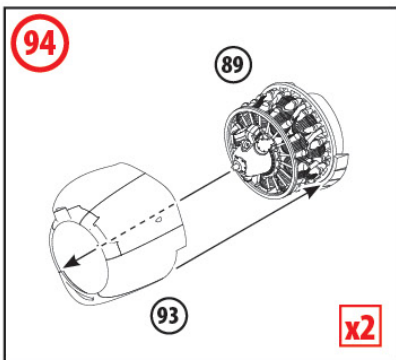
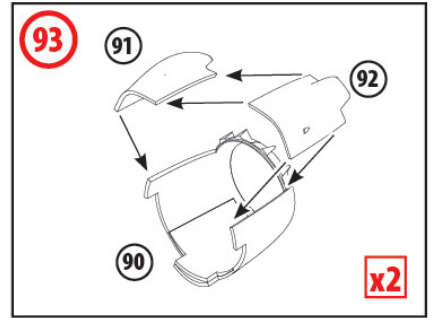
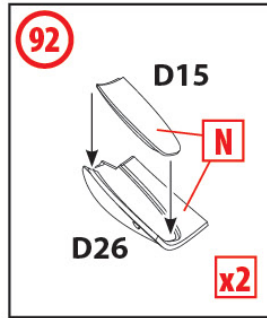
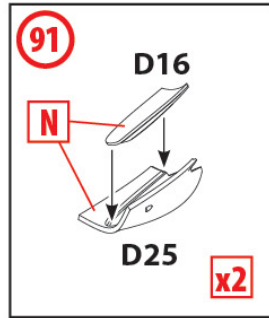
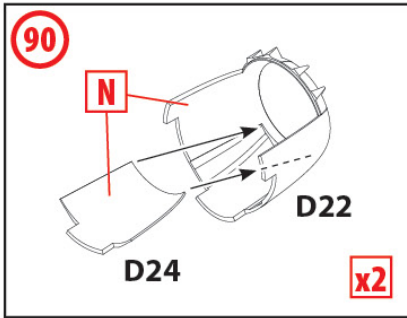
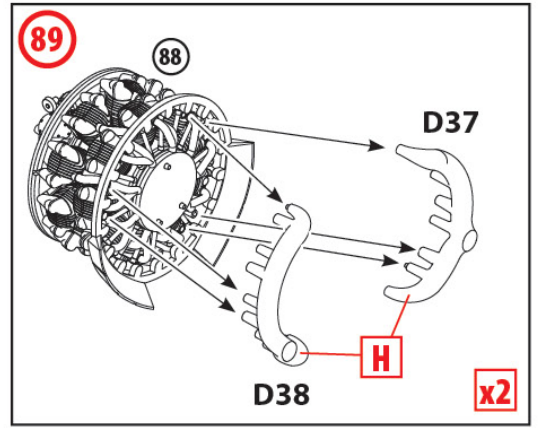
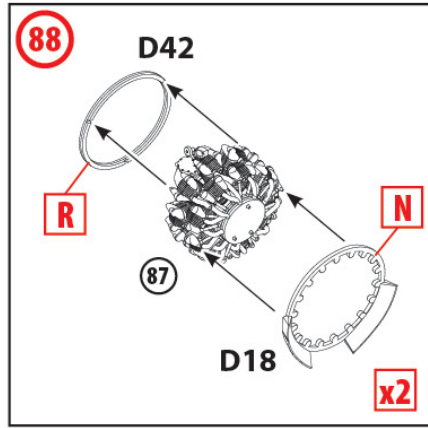
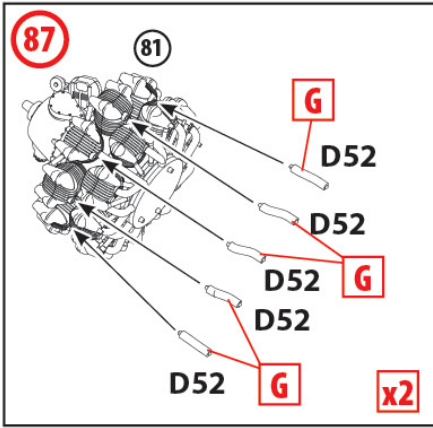

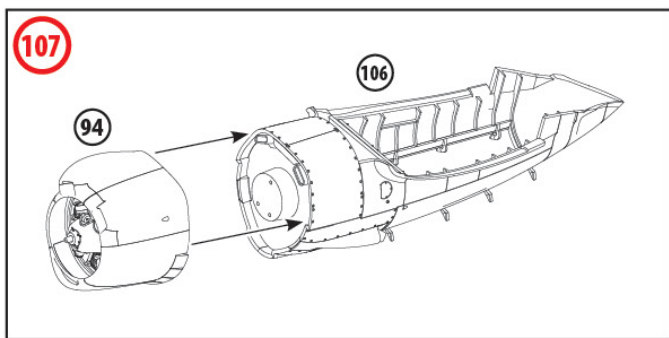
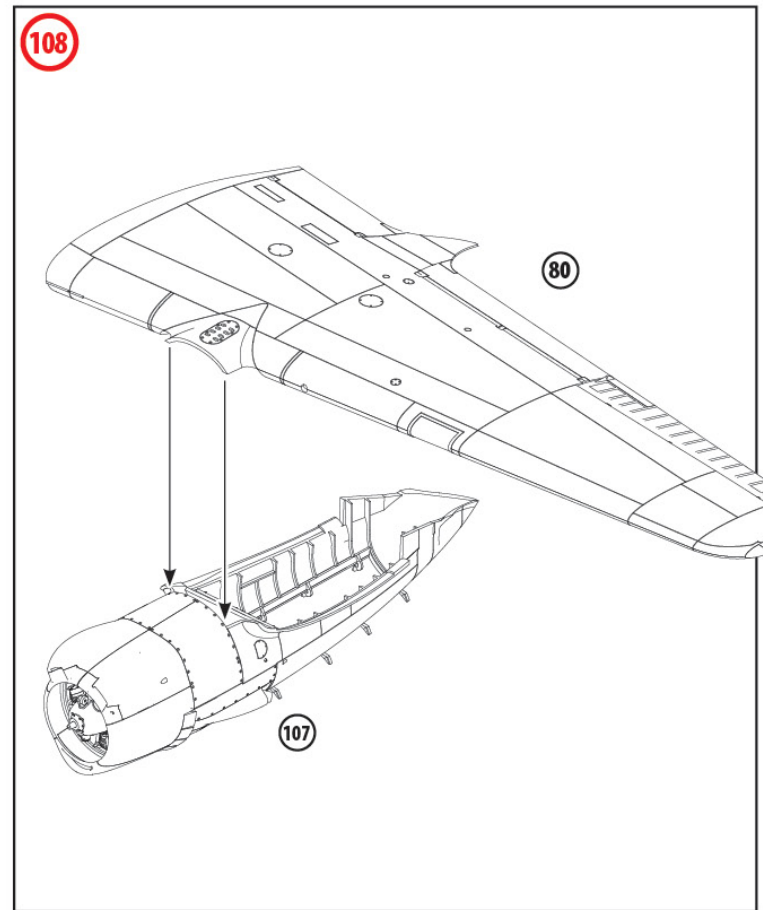
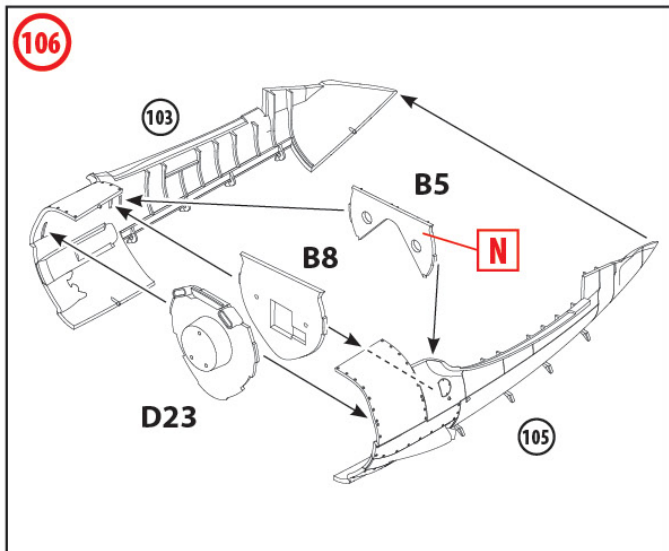
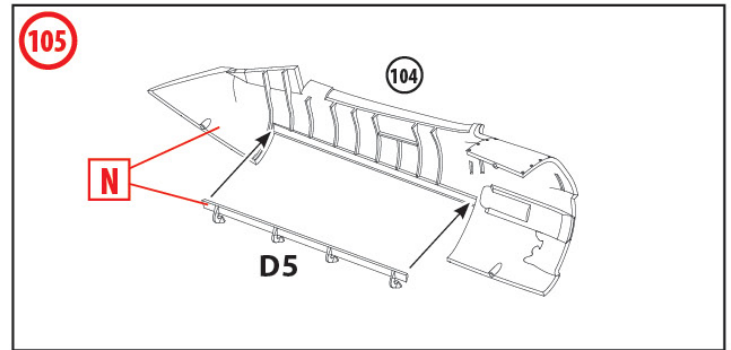
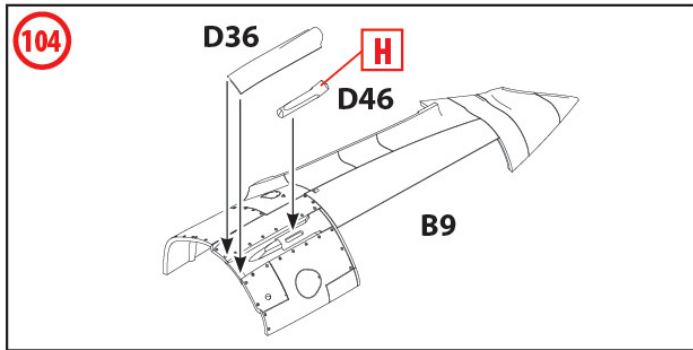
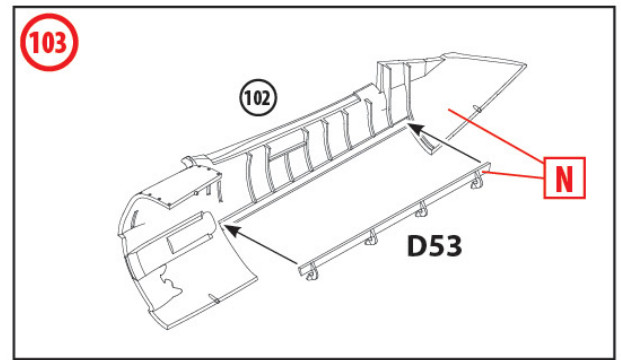
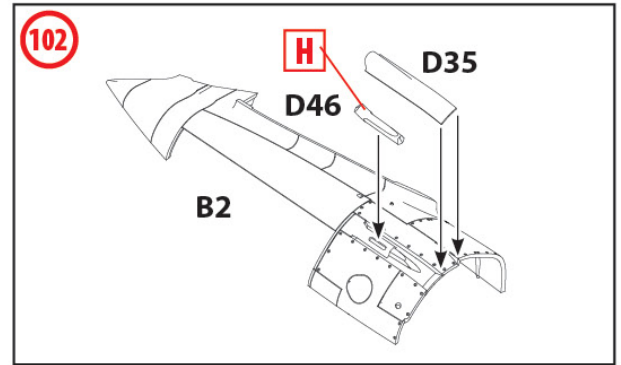
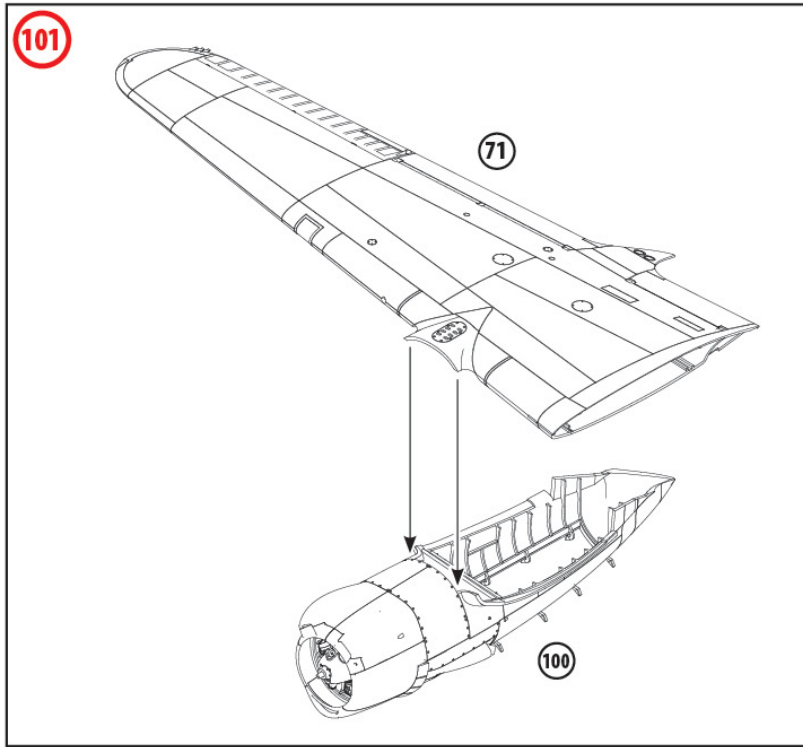

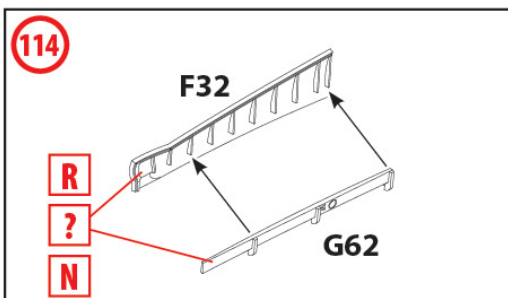
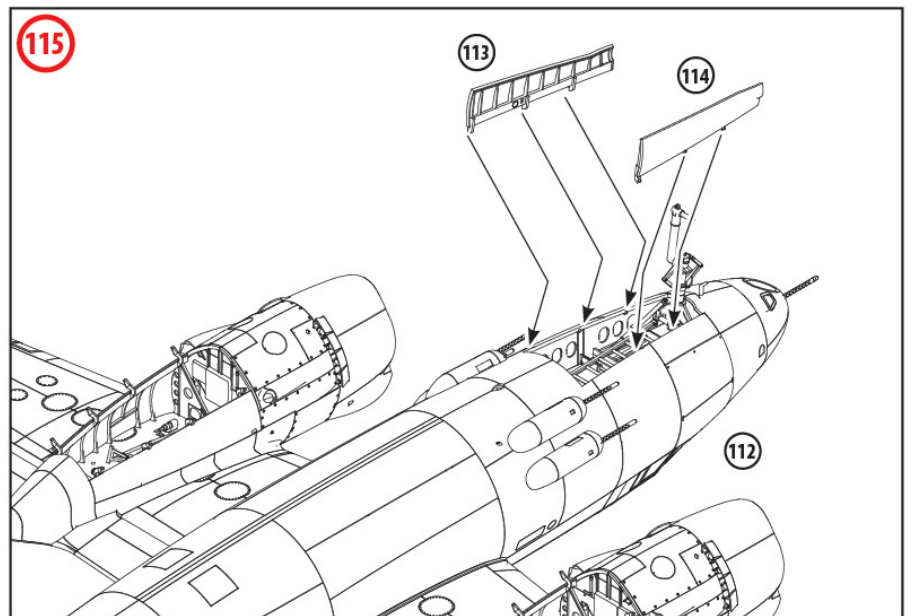
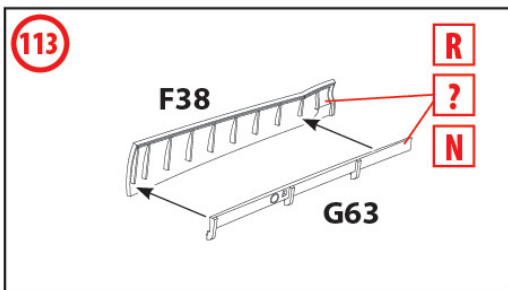
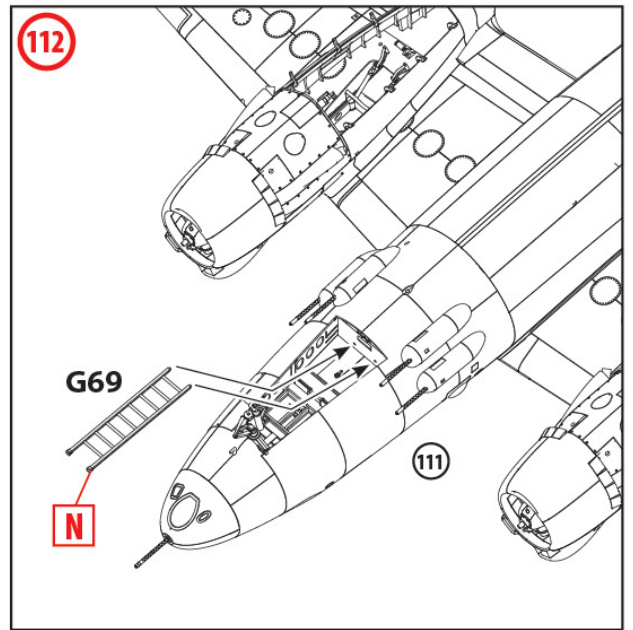
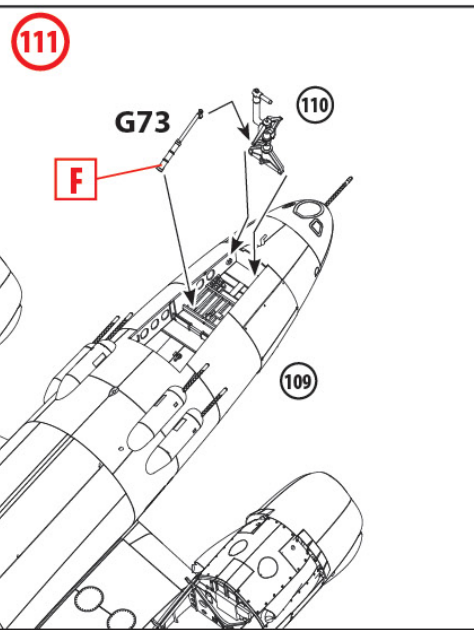
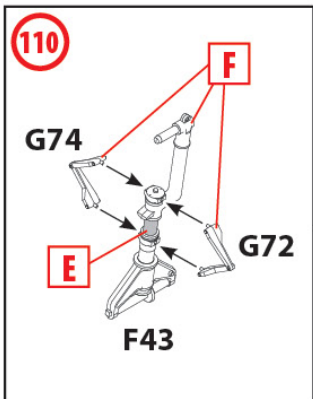
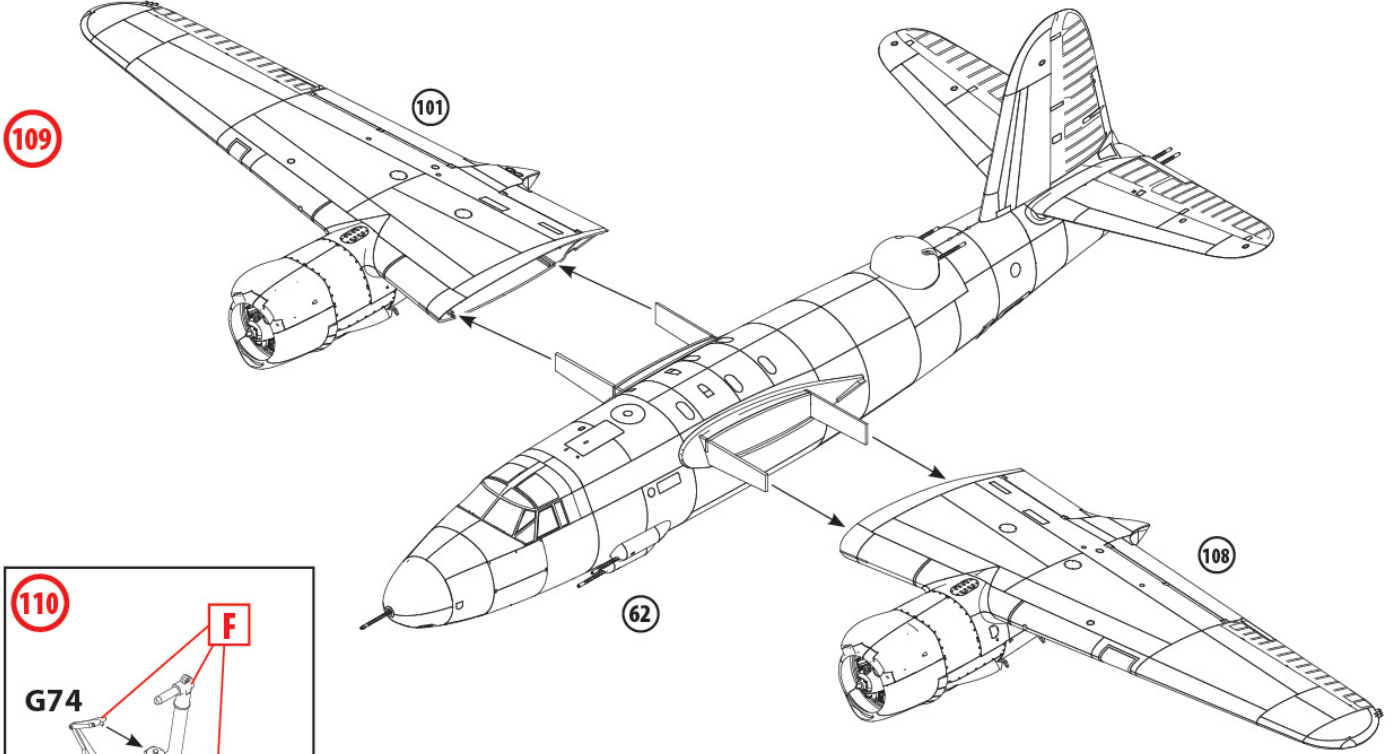

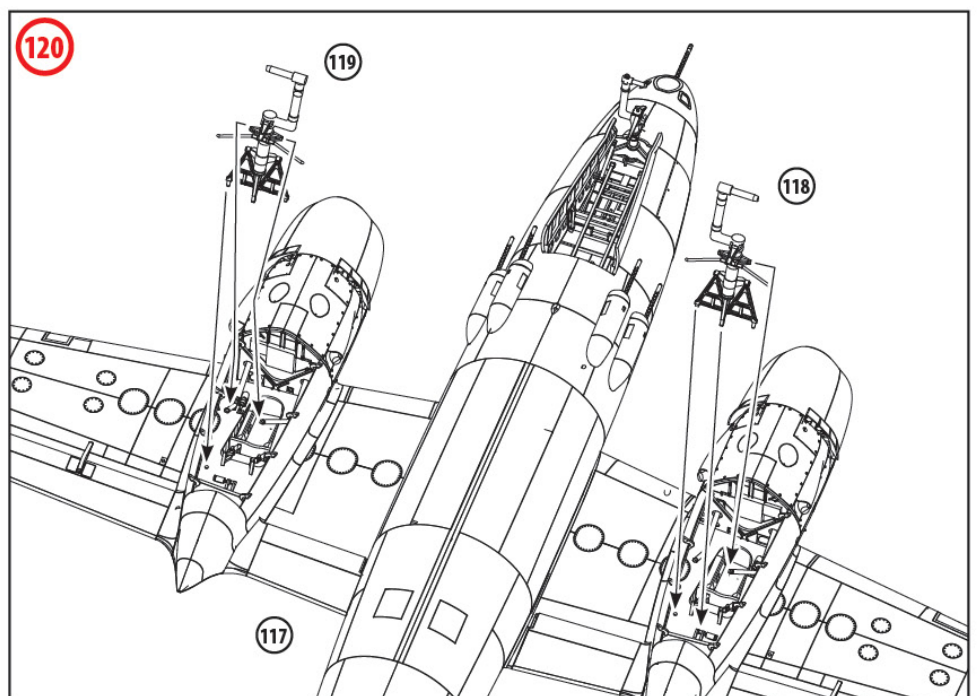
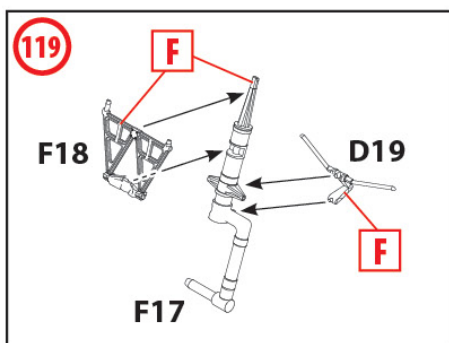
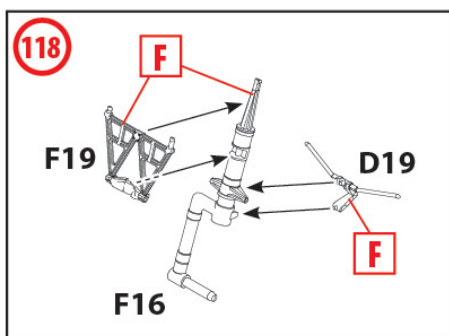
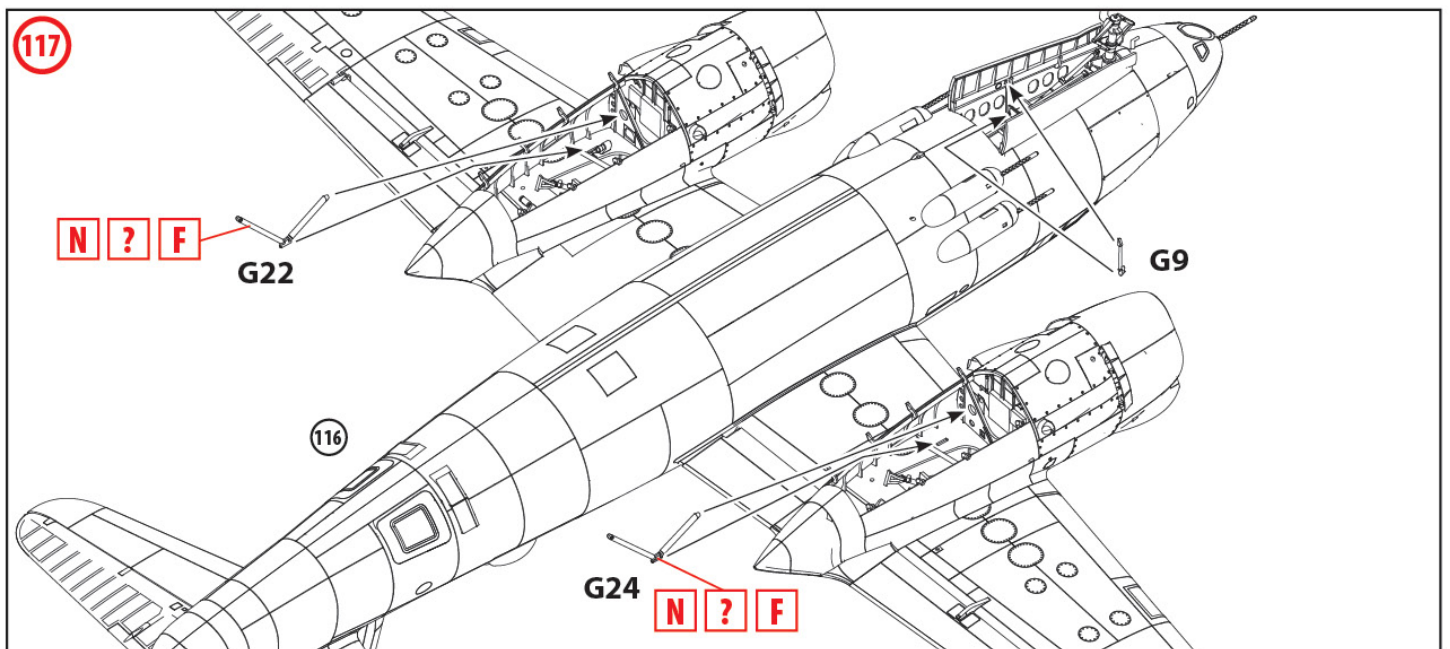
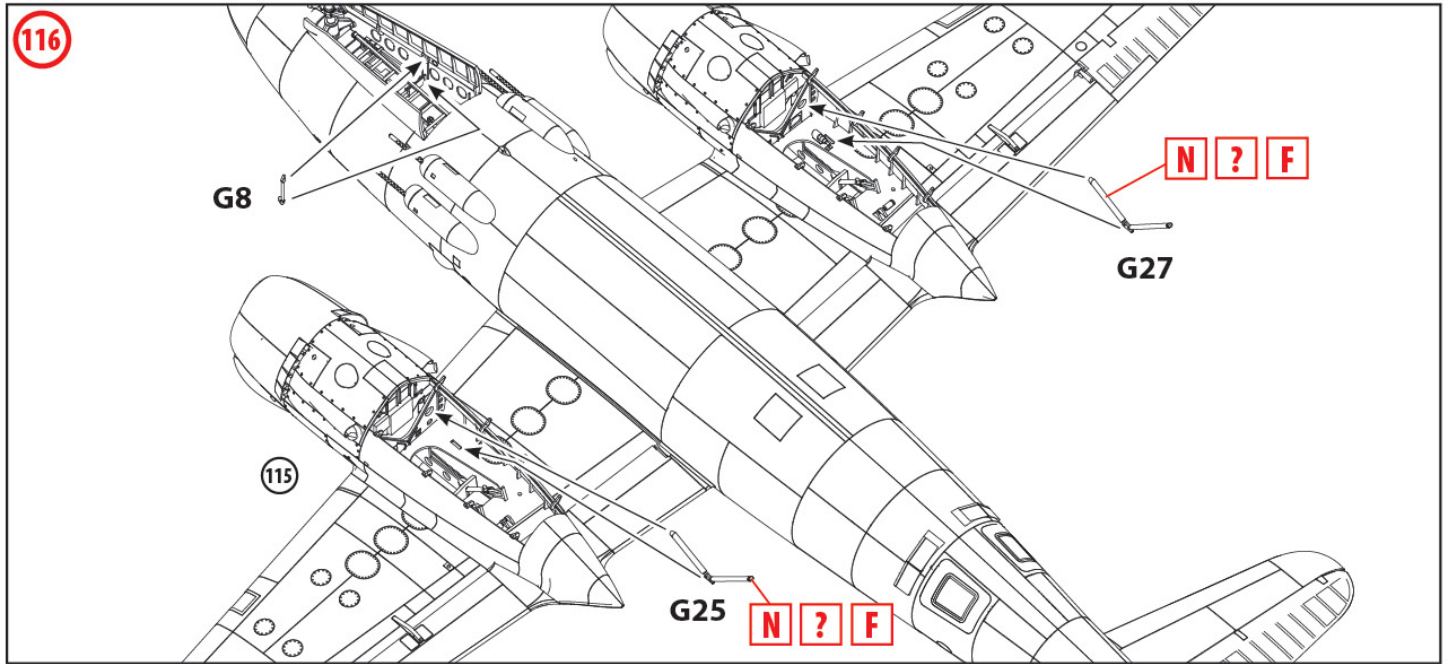

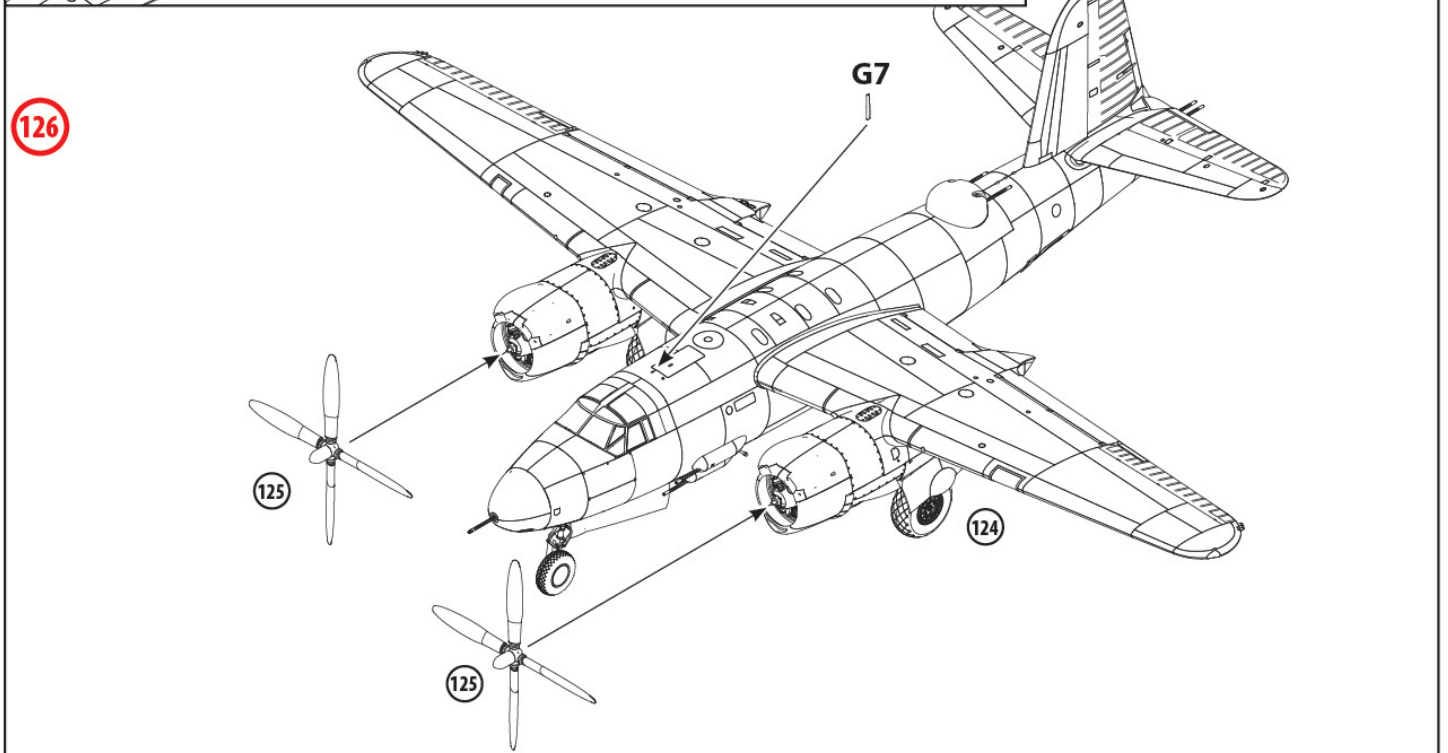
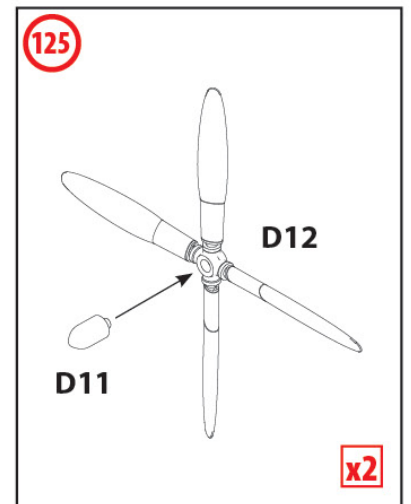
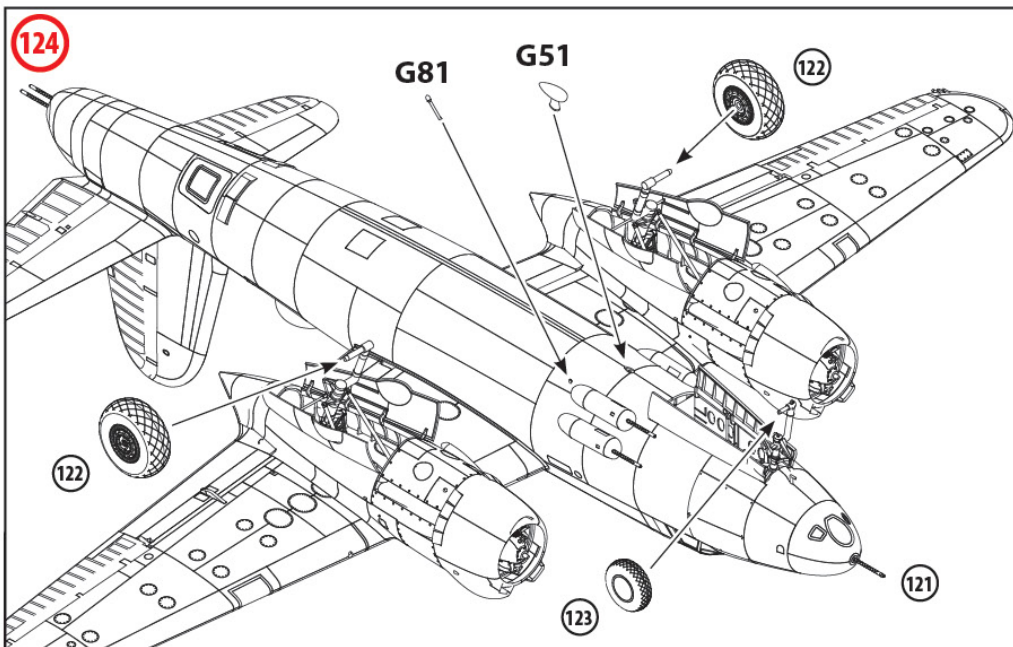
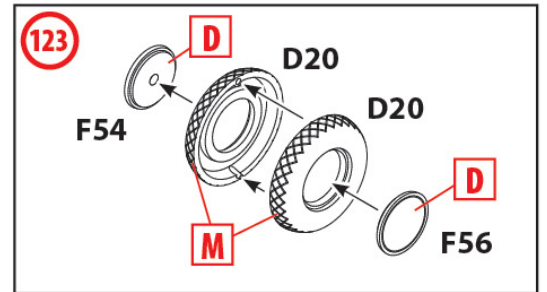
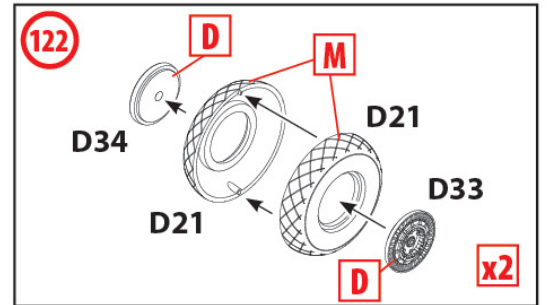
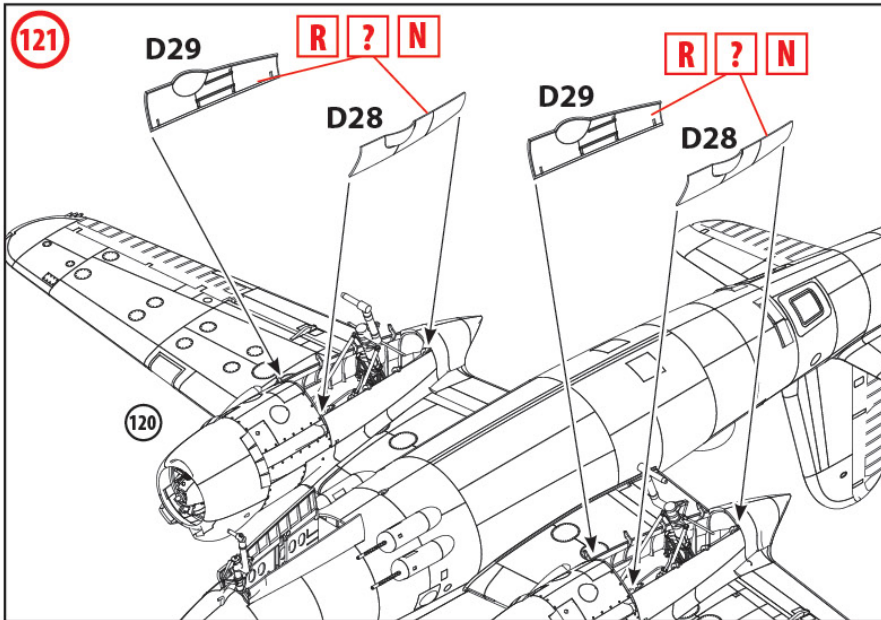

ЗОВНІШНЯ СТОРОНА ЧАСТИНИ НОСА
OUTSIDE OF THE NOSE PART

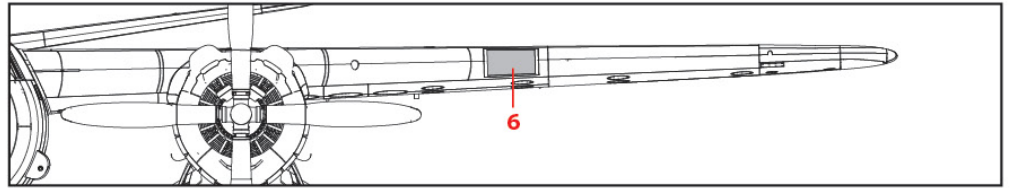
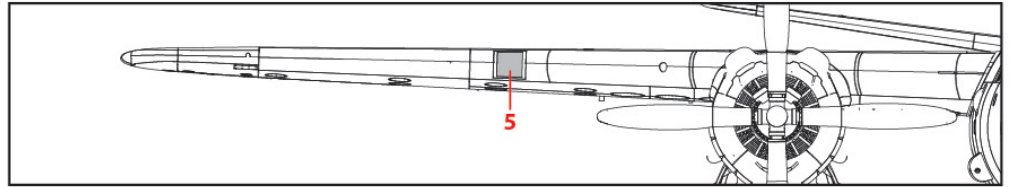
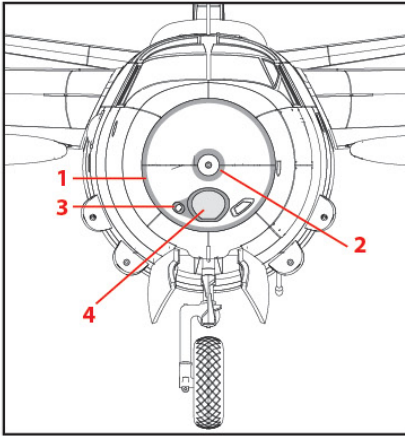

ВНУТРІШНЯ СТОРОНА ЧАСТИНИ НОСА
INNER SIDE OF THE NOSE PART

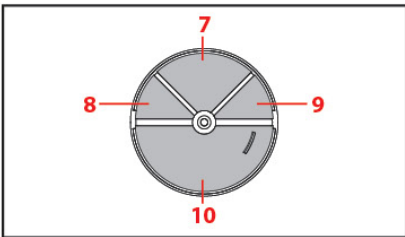

ПРАВА СТОРОНА ФЮЗЕЛЯЖУ FUSELAGE RIGHT SIDE

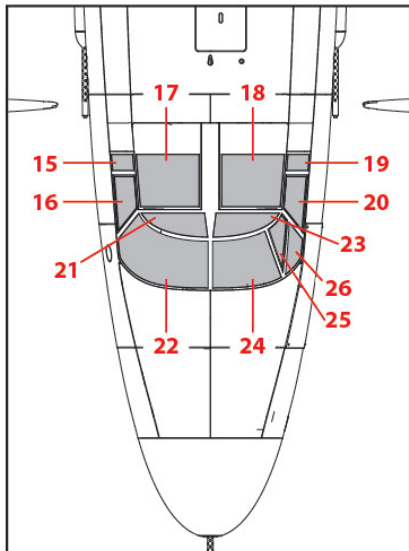
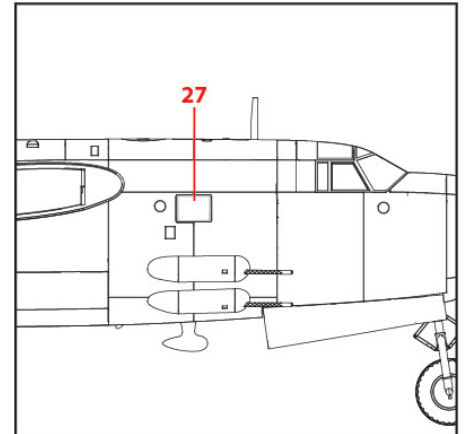
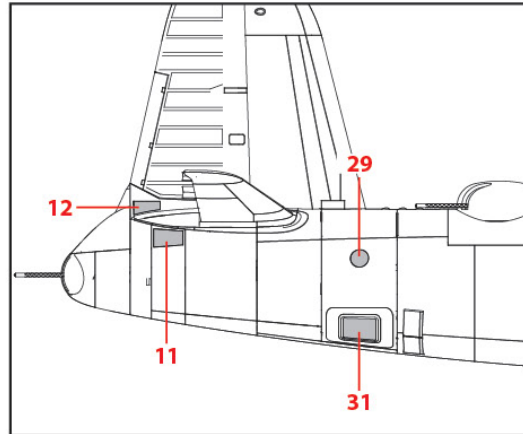

ЛІВА СТОРОНА ФЮЗЕЛЯЖУ FUSELAGE LEFT SIDE

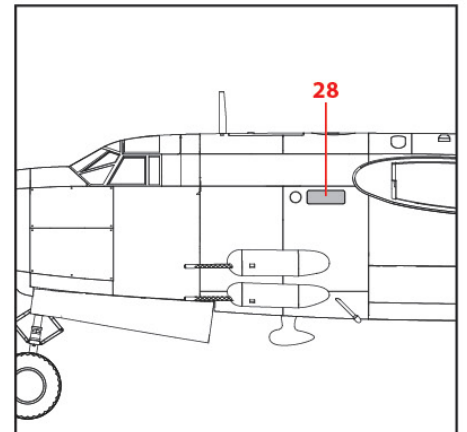
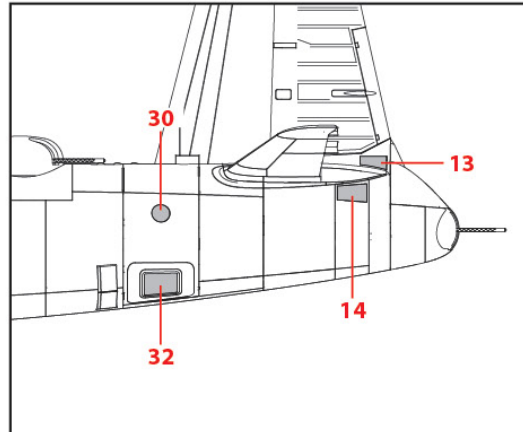

ШАБЛони масок
MASK TEMPLATES

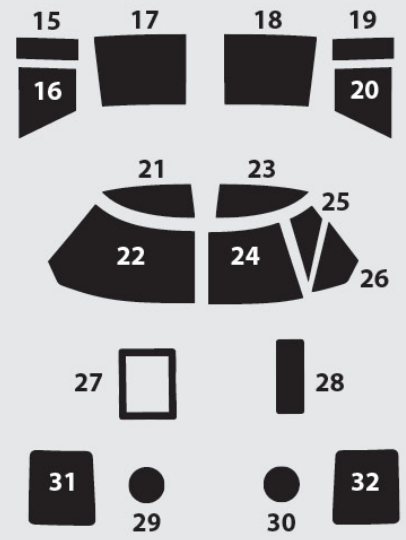
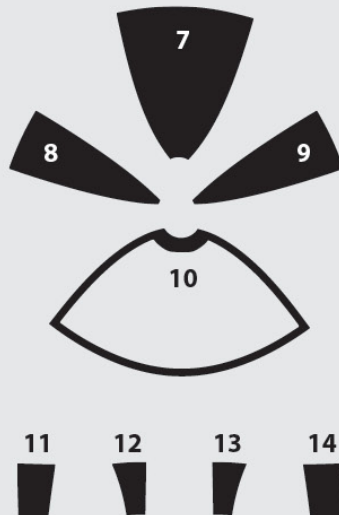
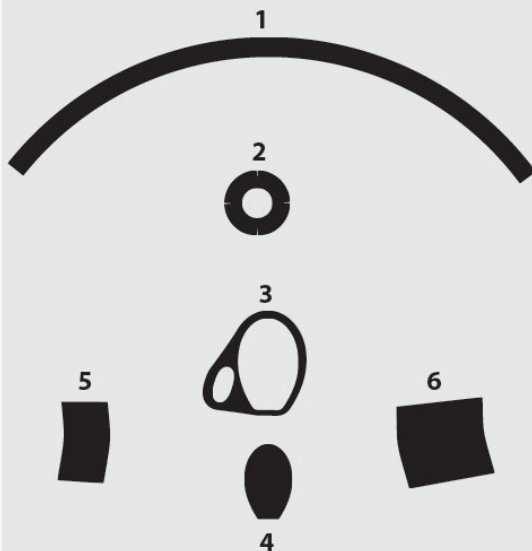

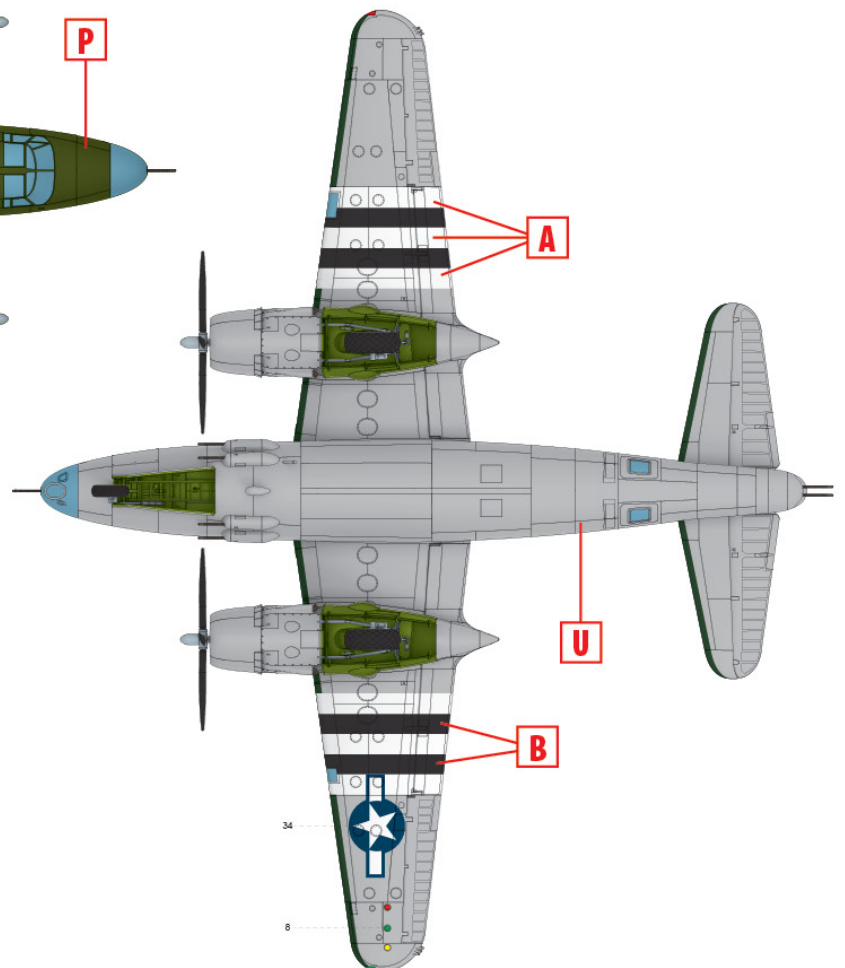
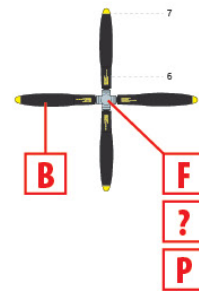
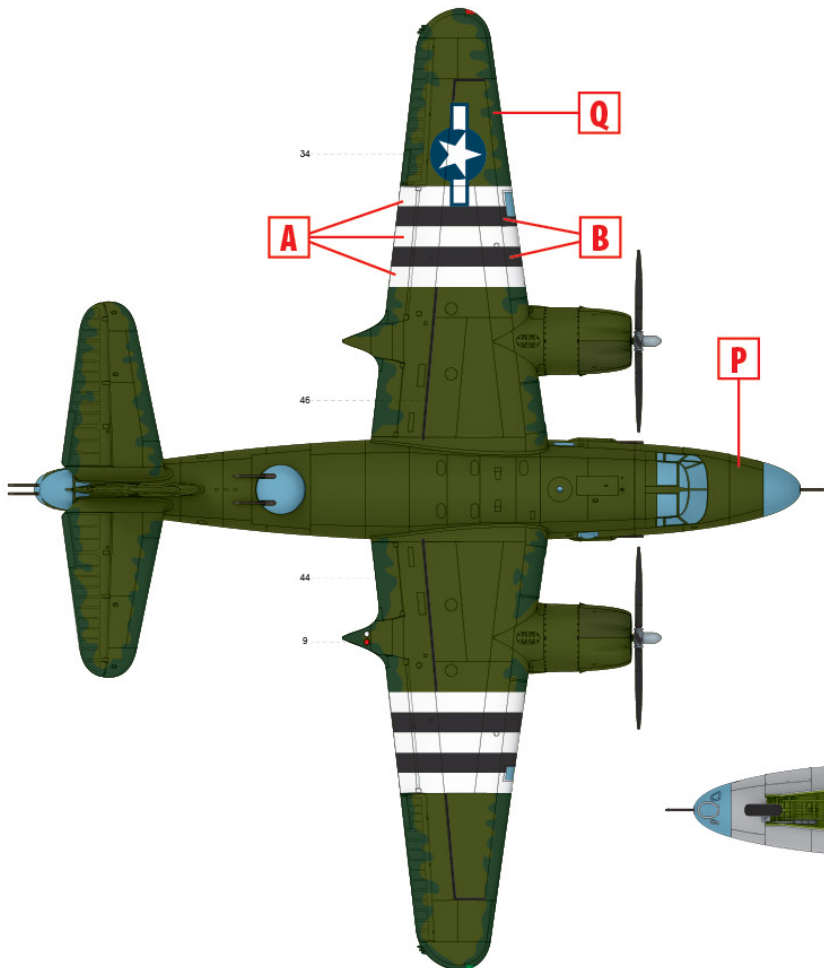
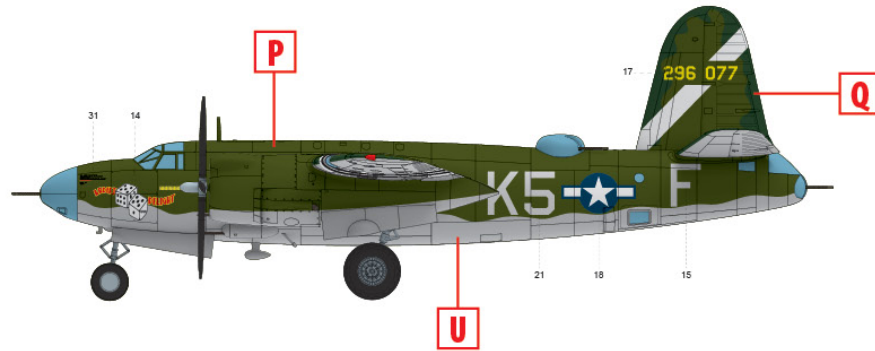
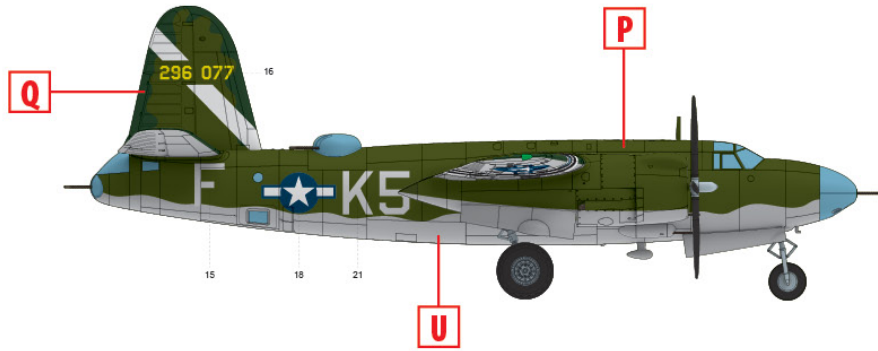

1) B-26B-55MA 42-96077 «Ladies Delight»,
584-а бомбардувальна ескадрилья, 394-а
бомбардувальна група, ймовірно Борем, Англія,
літо 1944 року

B-26B-55MA 42-96077 "Ladies Delight", 584th Bomb
Squadron, 394th Bomb Group, probably Boreham,
England, Summer 1944

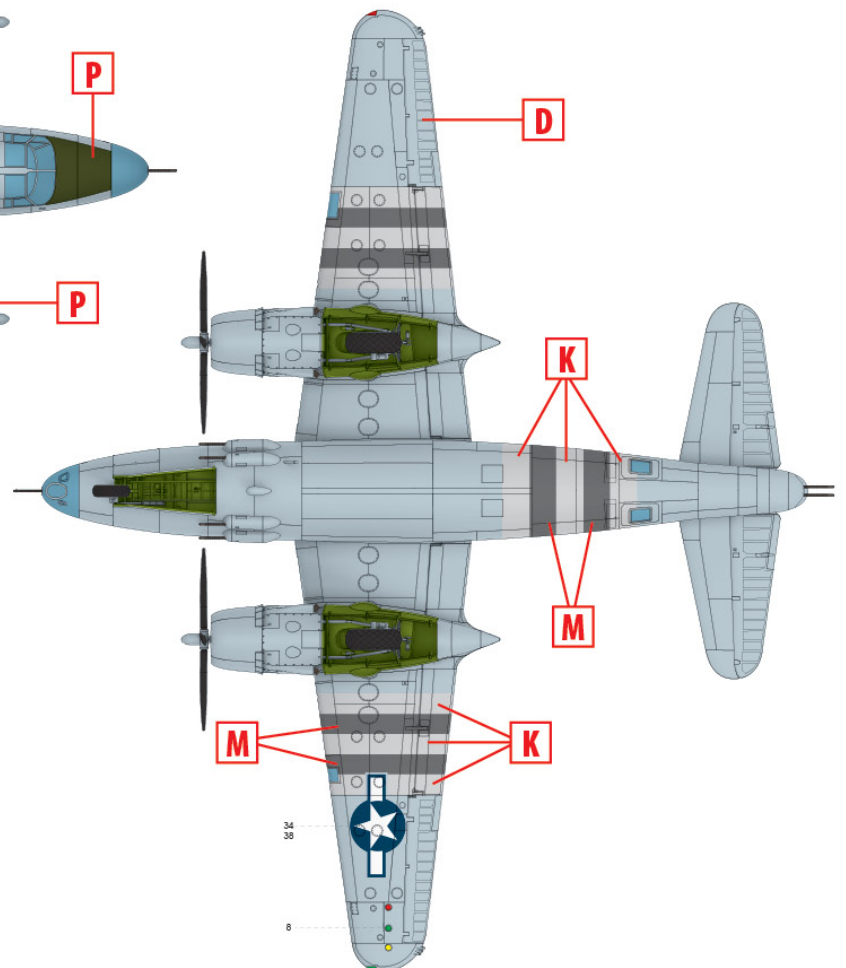
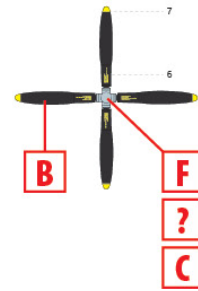
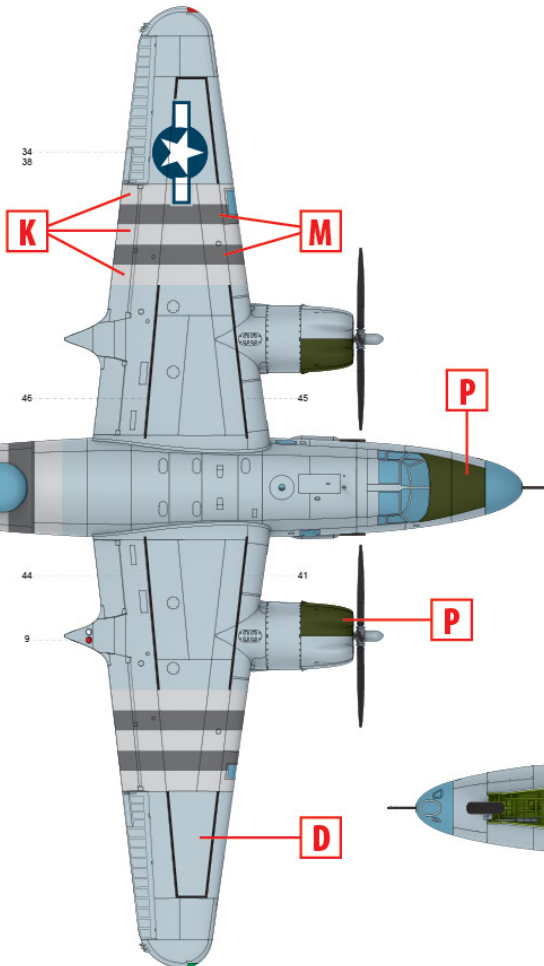
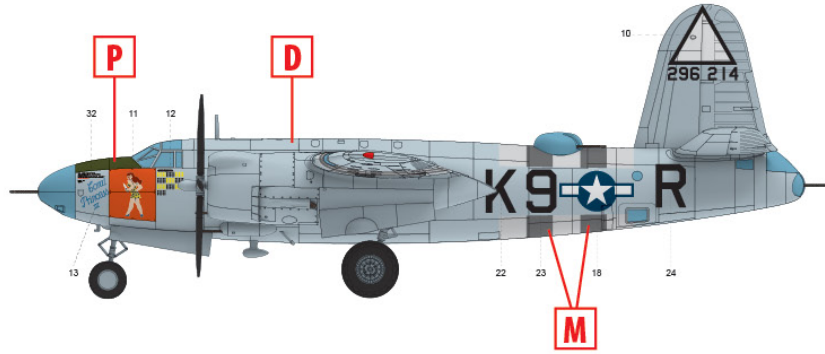
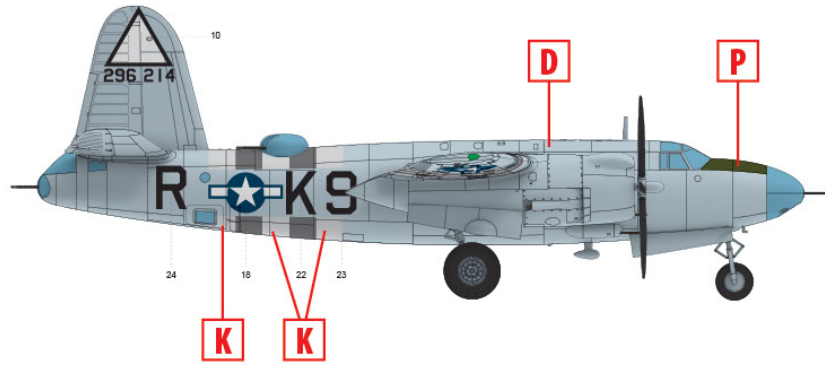

2) B-26B-55MA 42-96214 «Coral Princess III»,
494-а бомбардувальна ескадрилья, 344-а
бомбардувальна група, Понтуаз, Франція, осінь
1944 року

B-26B-55MA 42-96214 "Coral Princess III", 494th
Bomb Squadron, 344th Bomb Group, Pontoise,
France, Autumn of 1944

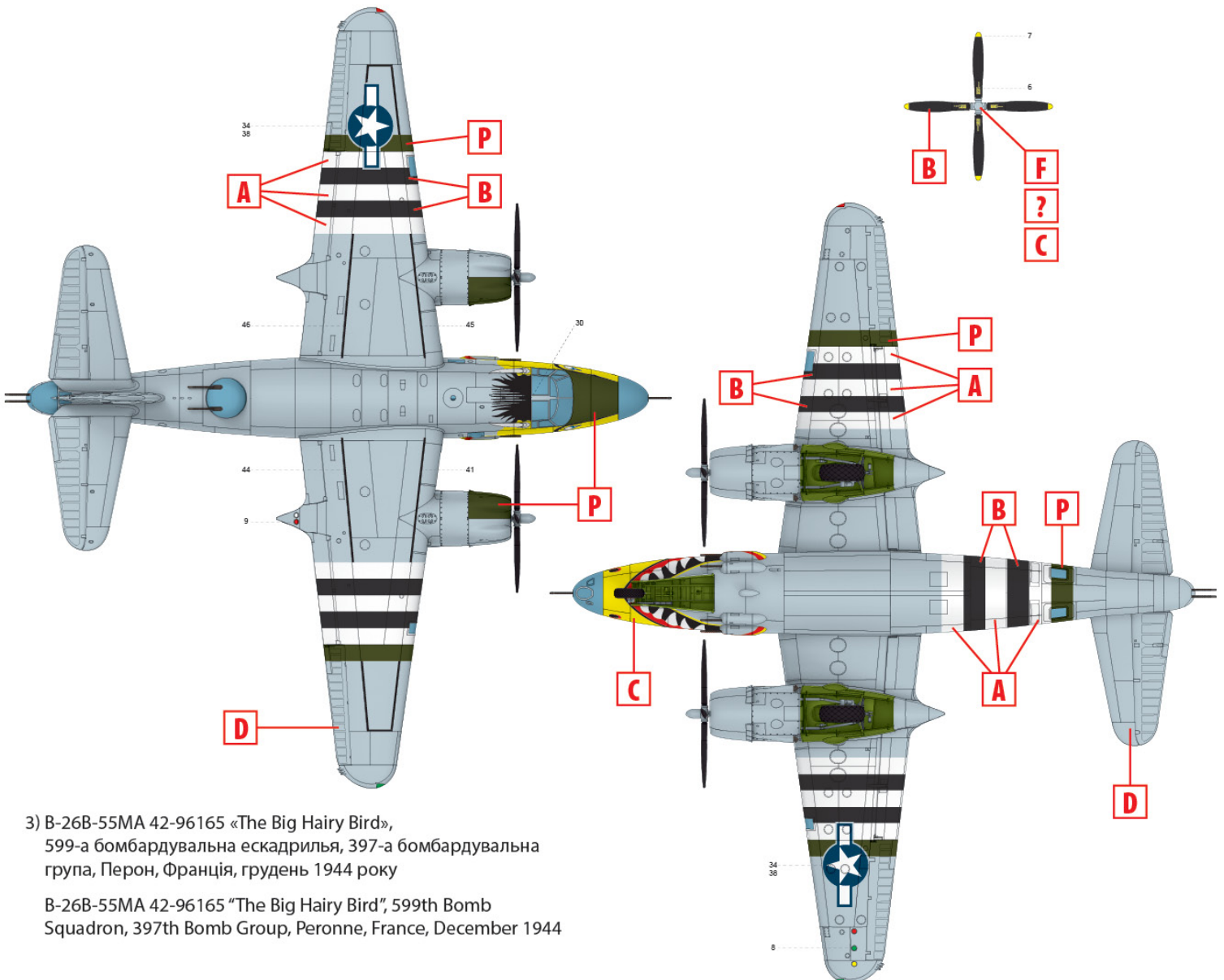
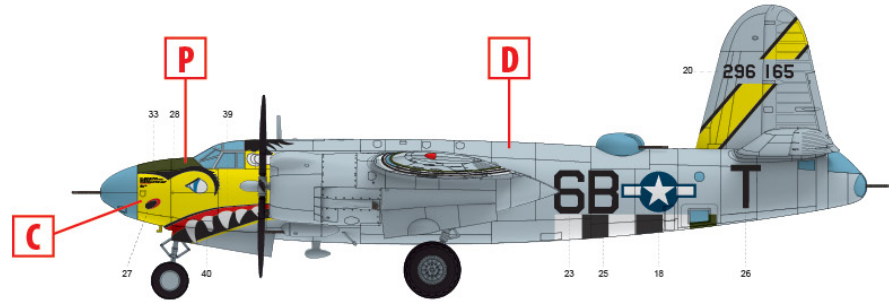
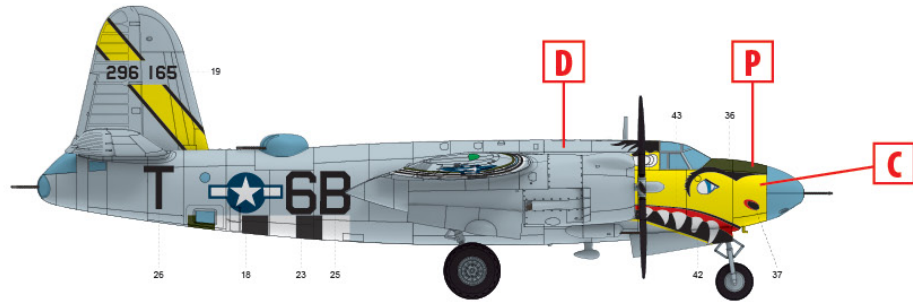

3) B-26B-55MA 42-96165 «The Big Hairy Bird»,
599-а бомбардувальна ескадрилья, 397-а бомбардувальна
група, Перон, Франція, грудень 1944 року

B-26B-55MA 42-96165 "The Big Hairy Bird", 599th Bomb
Squadron, 397th Bomb Group, Peronne, France, December 1944

ТОВ ІСМ Холдинг

вул. Бориспільська 9, корпус 64,
02099, Київ, Україна
Тел./факс: +38(044) 369 54 12
E-mail: export@icm.com.ua

ICM Holding

9 Boryspilska str., build. 64
02099, Kyiv, Ukraine
Tel./Fax: +38(044) 369 54 12
E-mail: export@icm.com.ua