



## F-15 E Strike Eagle

Die F-15 Eagle war ursprünglich als ein reines Jagdflugzeug entwickelt worden, obwohl bei der Konzeption von Seiten der amerikanischen Regierung eine Mehrzweckverwendung gefordert wurde. Bereits wenige Jahre nach der Indienststellung der F-15 wurde klar, dass sie das einzige amerikanische Flugzeug modernen Zuschnitts war, mit dem Hochgeschwindigkeitseinsätze in sehr geringen Höhen und unter allen Wetterbedingungen geflogen werden konnten. Bisher hatte diese Aufgabe die F-111 erfüllt, deren Lebensdauer sich jedoch stark dem Ende zuneigte.

Die Antwort auf die Frage nach einem Nachfolger war die F-15 DRF (Double Role Fighter), die auf dem F-15-Zweisitzer basierte und neben der modernsten Elektronik auch mit den besten Waffensystemen ausgerüstet werden sollte. Eine erste Maschine dieser Spezifikation beendete nach 200 Flügen am 30. April 1983 ihre Erprobungsphase – eine Entscheidung für die F-15E fiel jedoch erst am 24. Februar 1984, als die amerikanische Luftwaffe (USAF) bekanntgab, dass sie 1,5 Milliarden Dollar für die Umrüstung von 392 F-15 bereitstellen wolle.

Obwohl die neuen F-15E mit dem bisher verwendeten AGP-70-Bord-Radar ausgerüstet waren, sorgte eine leistungsfähigere Software für überlegene Leistungen. So kann man nun Ziele bereits in einer Entfernung von 160 Kilometer auffassen und durch zahlreiche Waffensysteme bekämpfen. Mit dem LANTIRN-System verfügt die F-15E über ein Terrainfolge-Modus für extreme Tiefflugeinsätze und Navigation unter fast allen Bedingungen. Dabei kann sie Belastungen von bis zu 9g (das neunfache der Erdbeschleunigung) standhalten.

Mit einer Waffenzuladung von maximal 11.098 kg übertrifft sie sogar noch die viermotorige Boeing B-29 – einen der größten Bomber des 2. Weltkriegs.

Eine Besonderheit der F-15E sind die an den Rumpfwänden angebrachten stromlinienförmigen Treibstofftanks CFT (Conformal Fuel Tanks), die zusätzlich 6.427 Liter Treibstoff enthalten. Sie können jederzeit wieder abgebaut werden und verfügen über Aufhängepositionen für eine Vielzahl von Außenlasten. So können außer AIM-120 AMRAAM auch Sparrow-Raketen und lasergesteuerte Bomben aufgenommen. Daneben verfügt die F-15E aber auch noch über eine M61-Vulcan-Kanone mit einem Kaliber von 20 mm und fünf rotierenden Läufen.

Ihre erste große Bewährungsprobe bestand die Strike Eagle im August 1990 im Konflikt mit dem Irak unter dem Namen „Desert Storm“. Obwohl die Maschinen zu diesem Zeitpunkt durch die Einführung des LANTIRN-Systems nicht völlig einsatzbereit waren, zeigten sie doch auch in der ungewohnten Einsatzrolle in mittleren Höhen ihr großes Potenzial. Trotzdem gingen durch die Bodenabwehr zwei Maschinen verloren.

Inzwischen hat sich die F-15E nach ihren letzten Erfolgen im Kosovo-Konflikt einen sehr guten Ruf als zuverlässiges und äußerst leistungsfähiges Waffensystem erworben.

### Technische Daten:

Spannweite:	13,05 m
Länge:	19,43 m
Höhe:	5,63 m
Triebwerke:	2 Mantelstromtriebwerke Pratt&Whitney F-100-PV-229
Leistung:	8073 kp Standschub 13200 kp mit Nachbrenner
Leergewicht:	14.378 kg
Startgewicht:	36.745 kg
Höchstgeschwindigkeit:	2.655 km/h
Höchstgeschwindigkeit in Bodennähe:	
Mit max. Waffenzuladung:	910 km/h
Steilgeschwindigkeit max:	254 m/sec.
Dienstgipfelhöhe:	18.290 m
Reichweite max:	5.745 km
Waffenzuladung:	11.098 kg
Startstrecke:	2.430 m

## F-15 E Strike Eagle

The F-15 Eagle was originally developed purely as a fighter, although the American government visualized it as a multirole aircraft. The F-15 had not been in service for many years before it became clear that it was the only state-of-the-art American plane, that could be used for high speed missions at very low altitudes and under all weather conditions. Until then this requirement had been met by the F-111 which was approaching the end of its service life. The answer to the question of a successor was the F-15 DRF (dual-role fighter), which was based on the F-15 two-seater and would be equipped with the best weapons systems combined with the latest electronics. The first machine to this specification ended its test phase on 30th April 1983 after 200 flights - however the decision in favour of the F-15E was not made until 24th February 1984, when the USAF made known its intention to allocate 1.5 billion dollars to upgrade the 392 F-15.

Although the new F-15Es were equipped with the same AGP-70 on board radar system as before, more powerful software gave it superior performance. Consequently it is now possible for it to detect targets at a distance of 160 km and fire at them with numerous weapons systems. The LANTIRN system also gives the F-15E a terrain-following mode for extremely low-flying missions and navigation under almost any conditions. In addition it can withstand loads of up to 9 g (nine times acceleration due to gravity). Its maximum weapon load of 11,098 kg exceeds that of the four engined Boeing B-29 - one of the largest World War II bombers. A particular feature of the F-15E is the low-drag CFCs (conformal fuel tanks) fitted to the sides of the fuselage containing an extra 6,527 litres of fuel. They can be removed at any time and have tangential attachments for a variety of external stores. Thus in addition to AIM-120 AMRAAMs, they can take Sparrow rockets and laser-guided bombs. The F-15E also has a 20 mm M61 Vulcan six-barrel cannon. The Strike Eagle underwent its first major trial in August 1990 in Operation Desert Storm in Iraq. Although at that time the planes were not fully operational due to the introduction of the LANTIRN system, they proved their great potential even in an unaccustomed role at medium altitude. Despite this two machines were lost to ground defences. In the meantime, following its latest successes in the Kosovo conflict, the F-15E has gained a very good reputation as a reliable and extremely powerful weapons system.

### Technical data:

Wing span	13.05 m
Length	19.43 m
Height	5.63 m
Engines	2 Pratt & Whitney F-100-PV-229 turbofans
Capacity	8073 kp static jet thrust 13200 kp with afterburner
Operating empty weight	14,378 kg
Take-off weight	36,745 kg
Maximum speed	2,655 km/h
Max. speed at zero altitude	
with max. weapon load	910 km/h
Max. rate of climb	254 m/sec
Service ceiling	18,290 m
Max. range	5,745 km
Weapon load	11,098 kg
Take-off distance	2,430 m





**A**

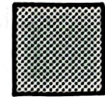
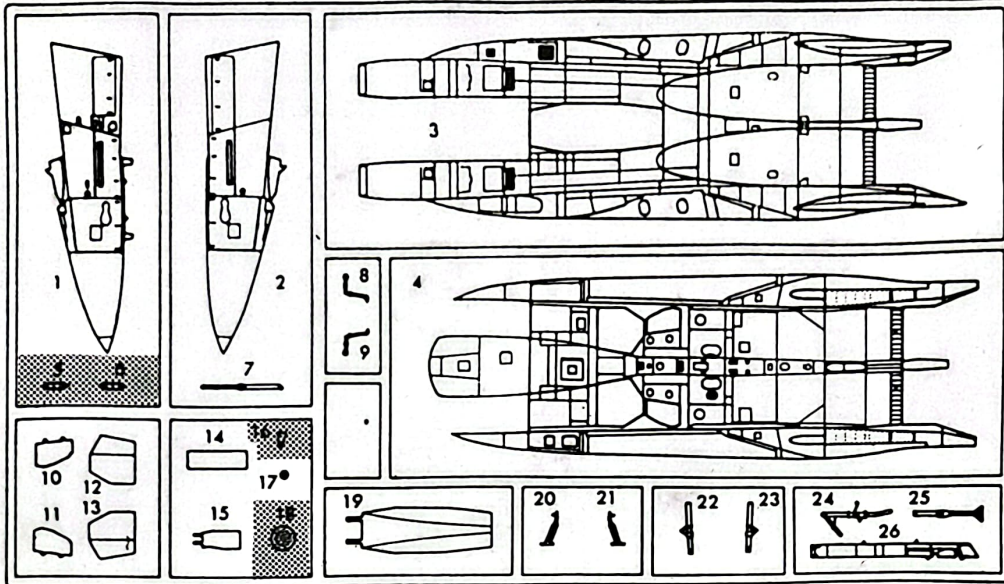

Nicht benötigte Teile  
 Parts not used  
 Pièces non utilisées  
 Niet benodigde onderdelen  
 Peças não utilizadas  
 Parti non usate  
 Inte använda delar  
 Tarpeettomat osat  
 Ikke nødvendige dele  
 Deler som ikke er nødvendige  
 Неиспользованные детали  
 Elementy niepotrzebne  
 μη χρησιμοποιούμενα εξαρτήματα  
 Gereksiz parçalar  
 Nepotřebné díly  
 fel nem használt alkatrészek  
 Nepotrební deli

**B**

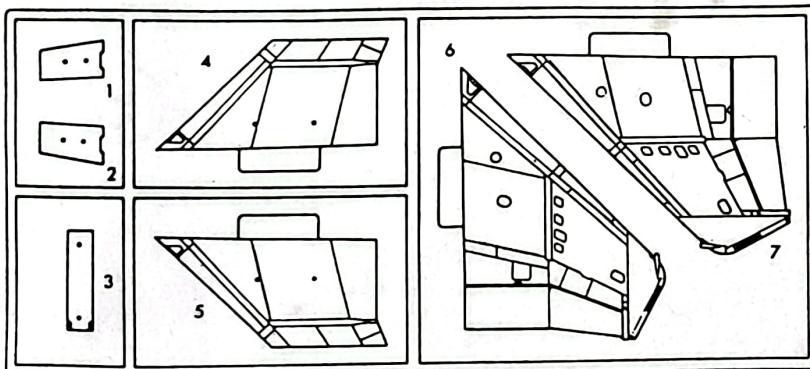

**G**

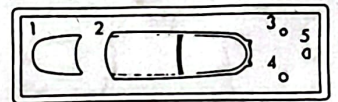

**C**

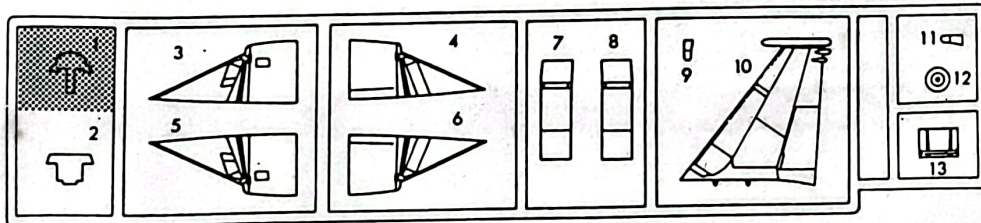

**D**  
2x

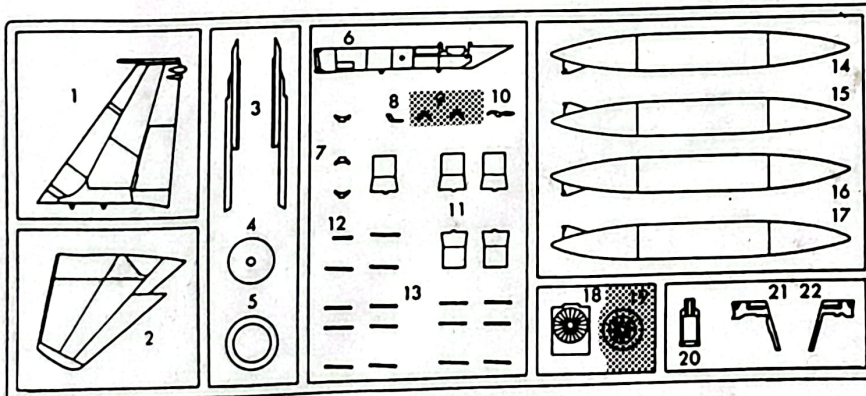

**E**

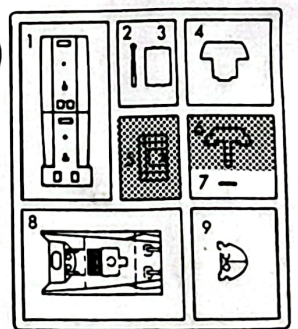

**F**

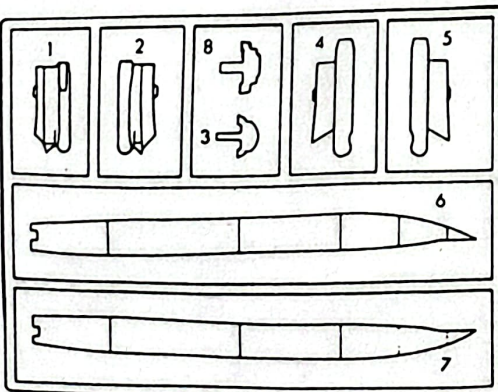

**H**  
2x

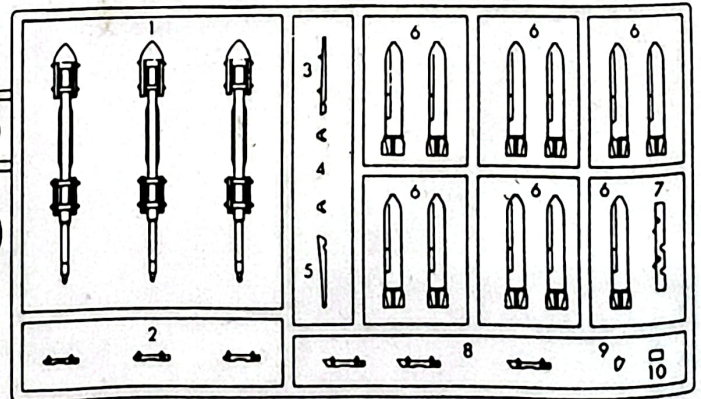

# 1 2X

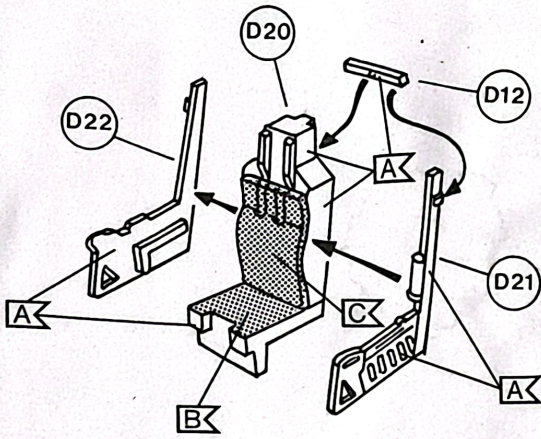

# 2

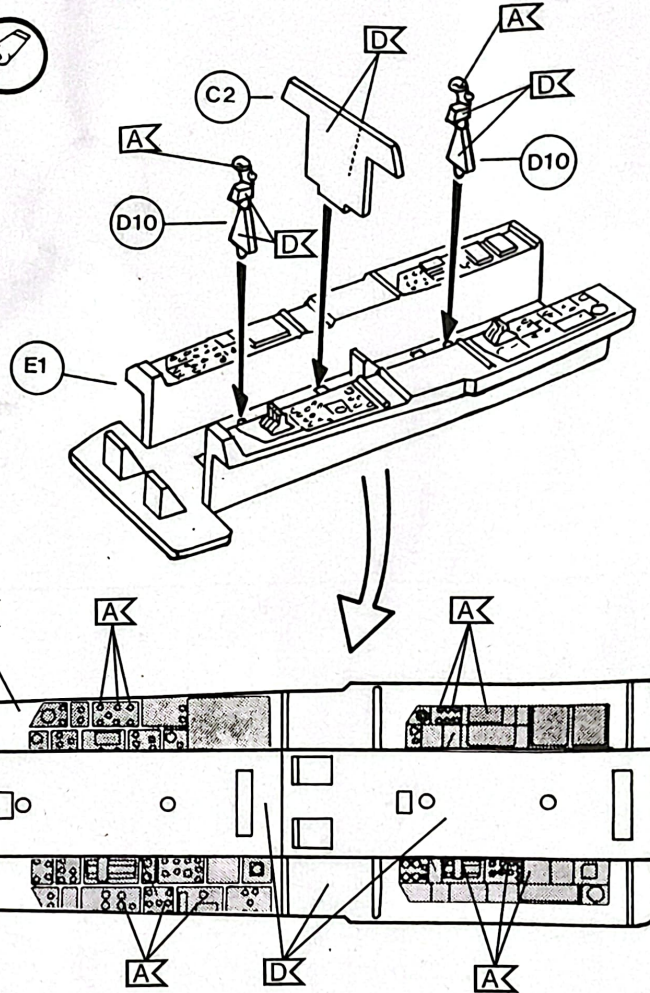

# 3

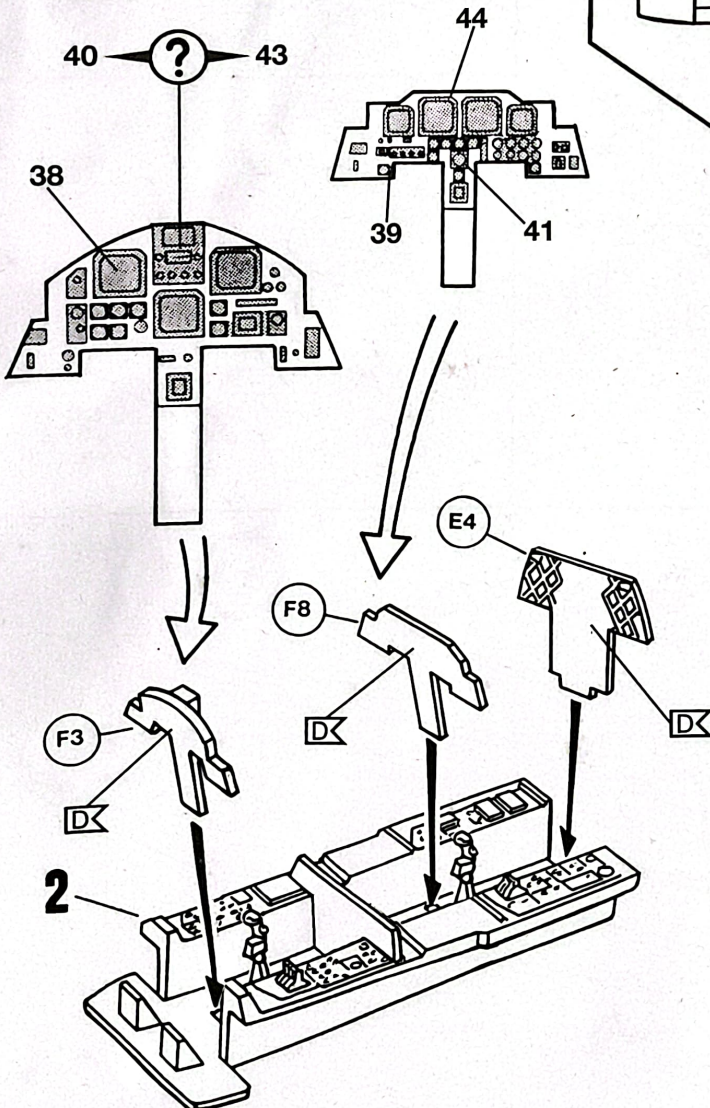
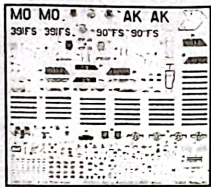

# 4

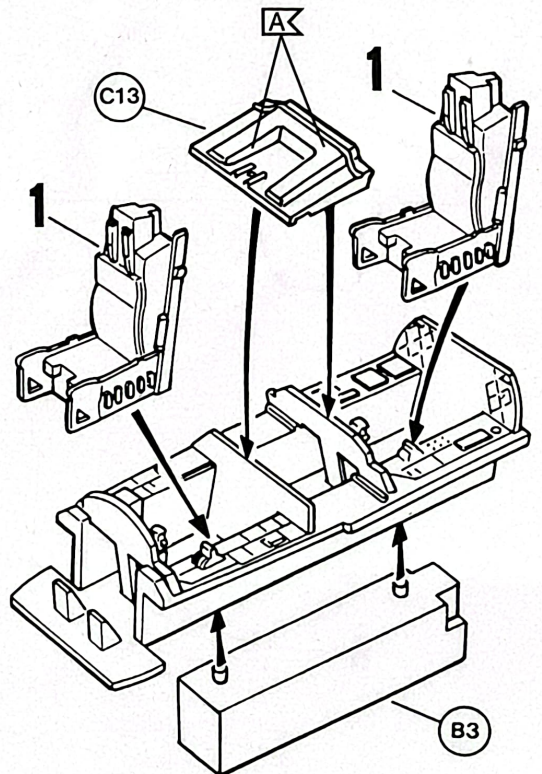

# 5

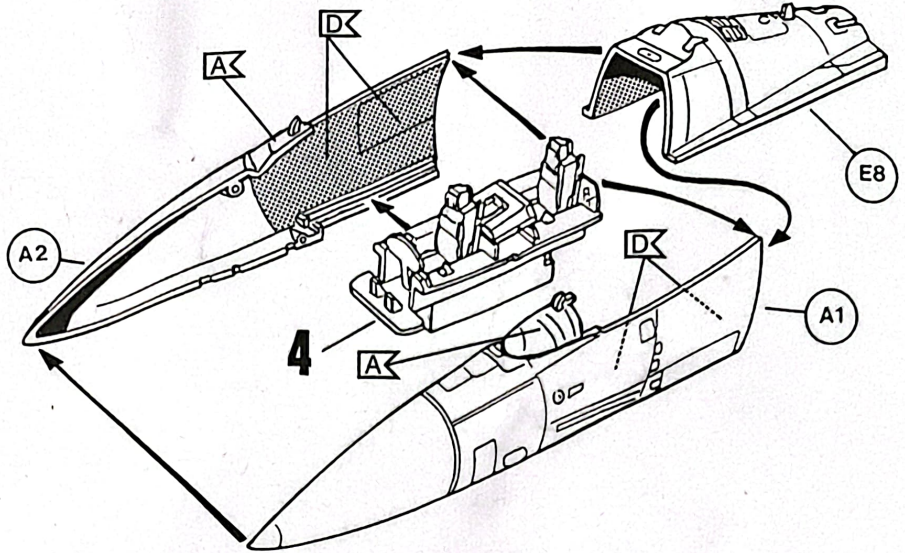

# 6

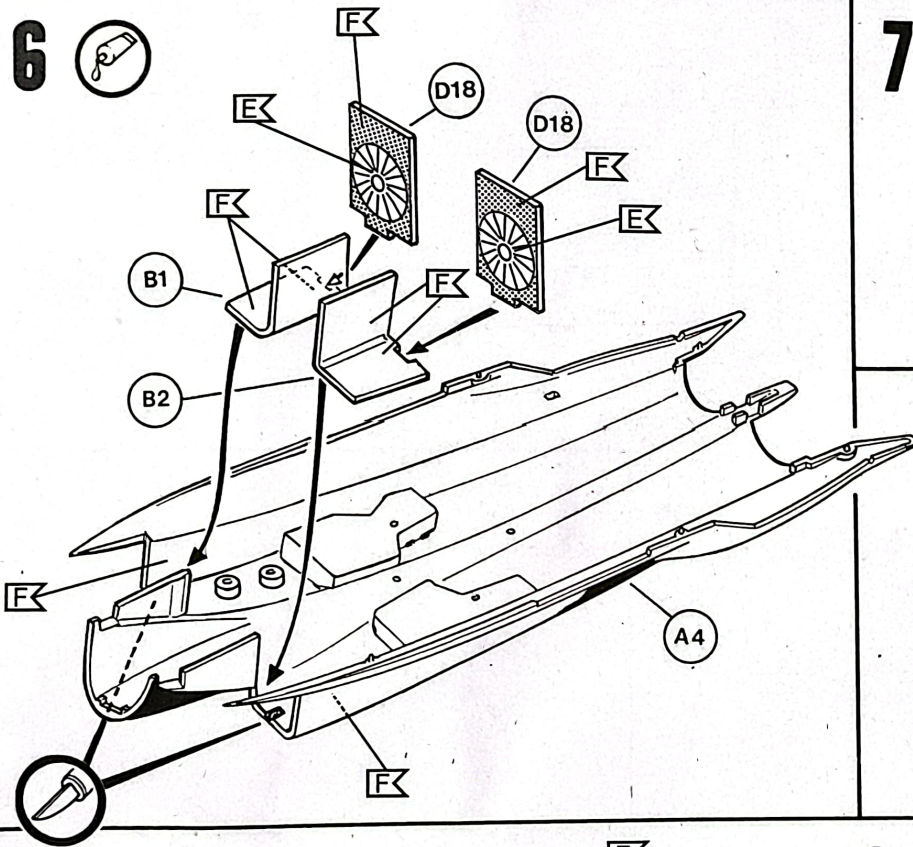

# 7

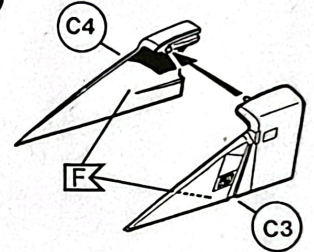

# 8

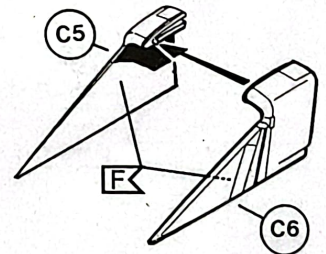

# 9

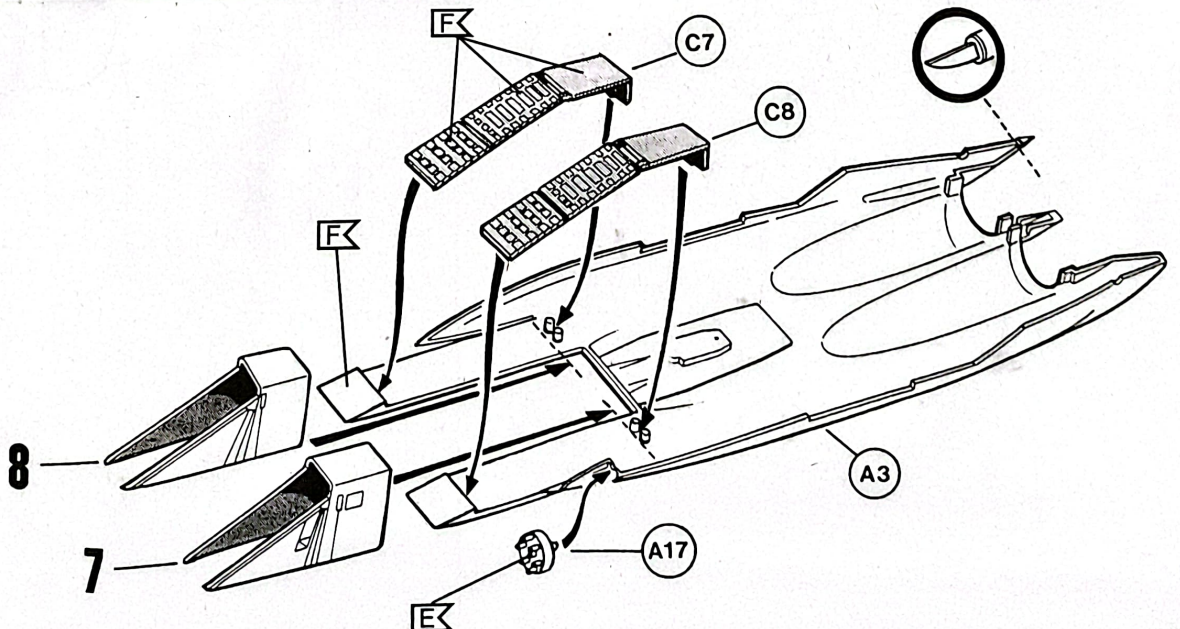

10 

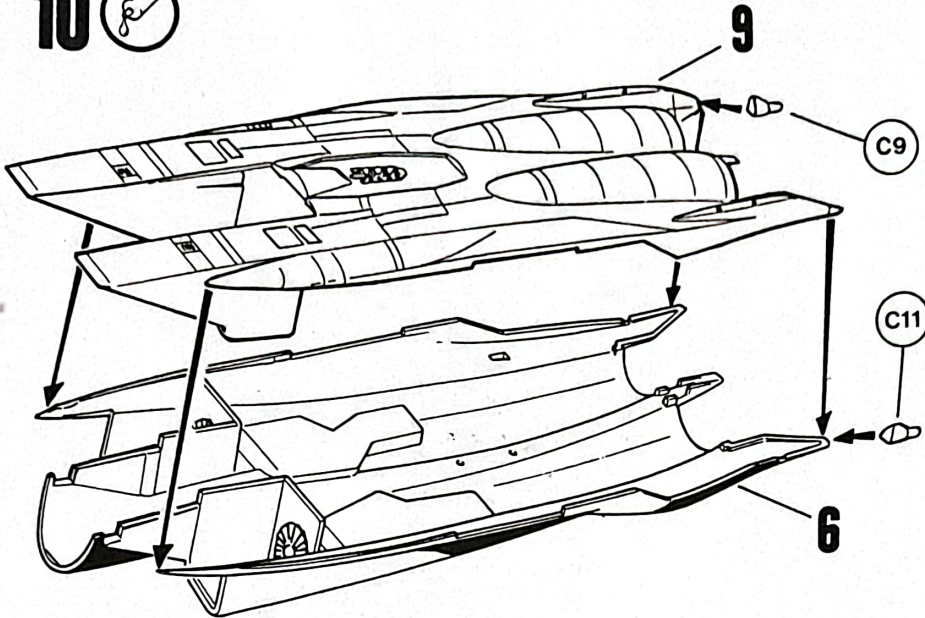

11 

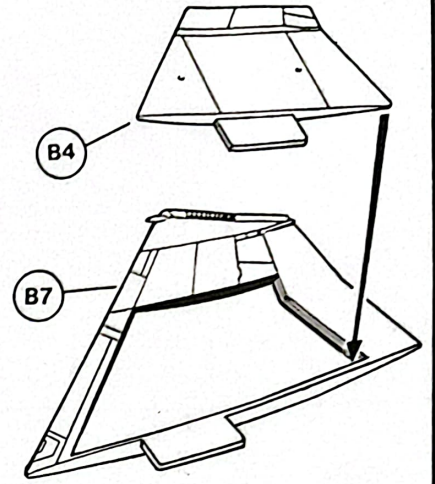

12 

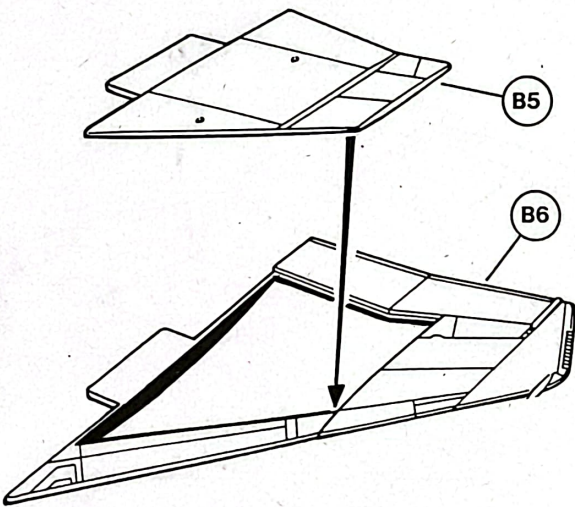

13  2X

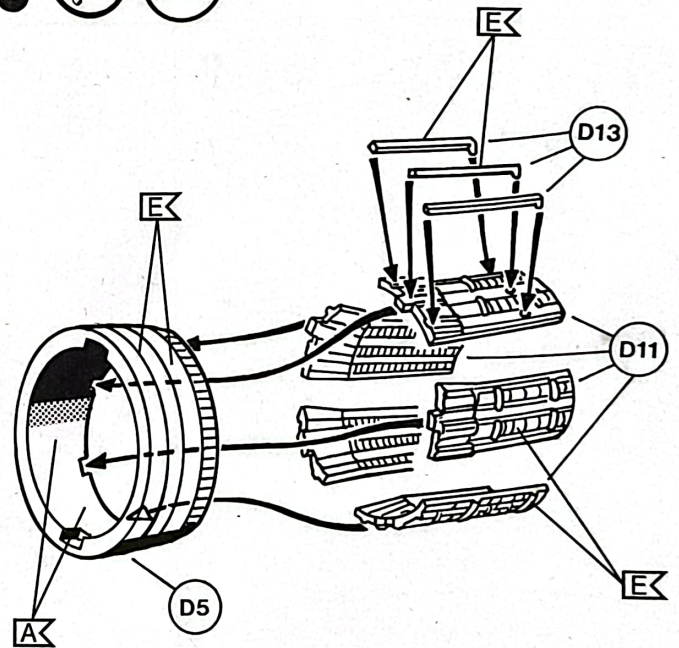

14 

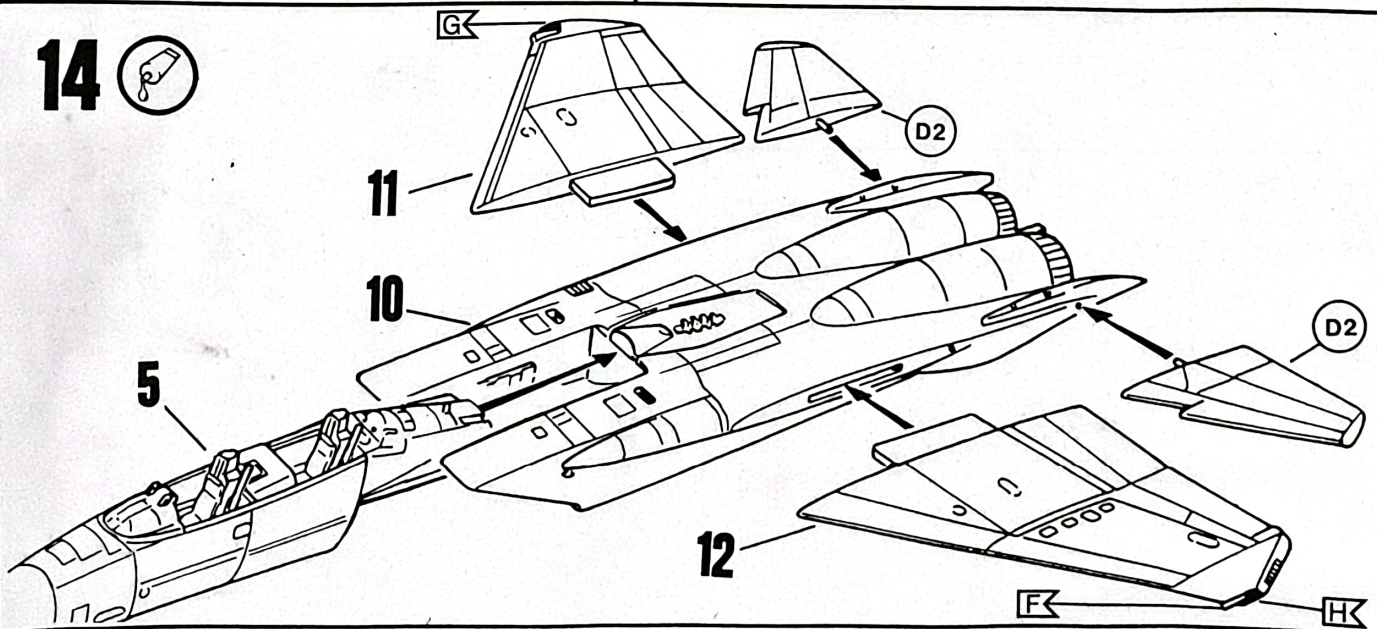

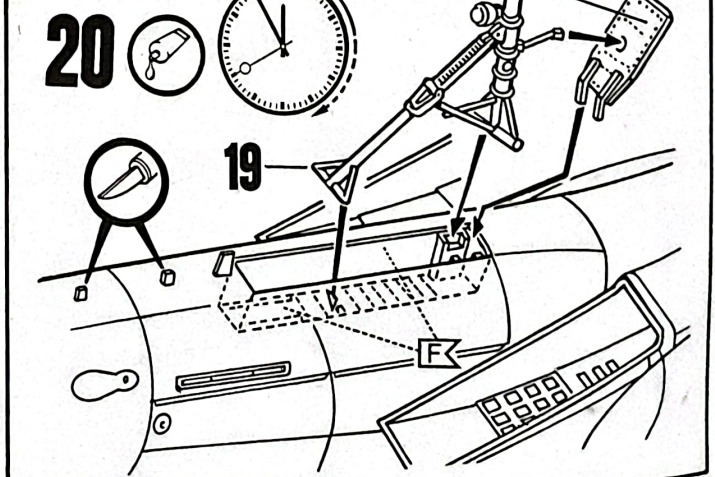
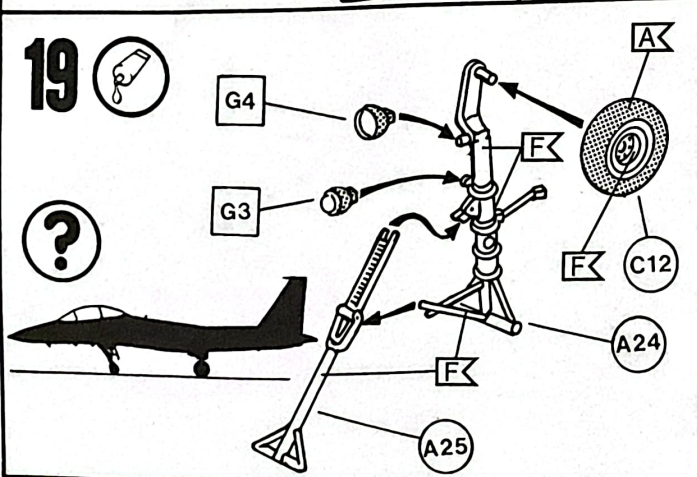
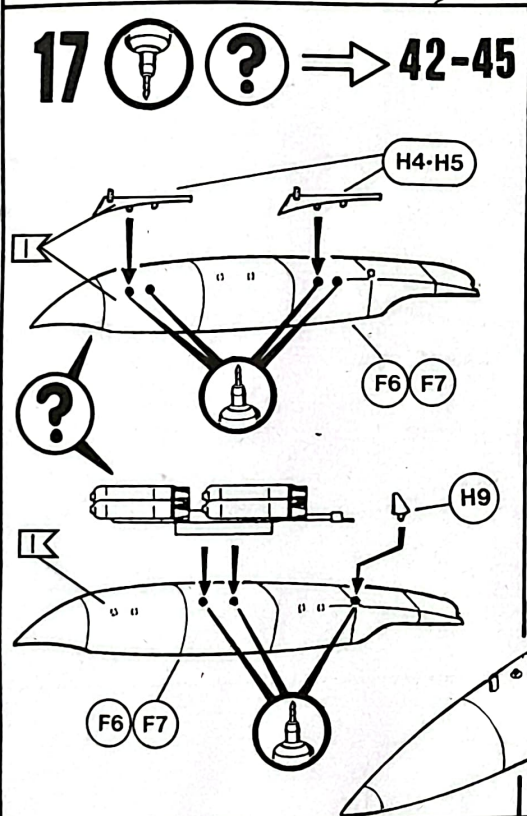
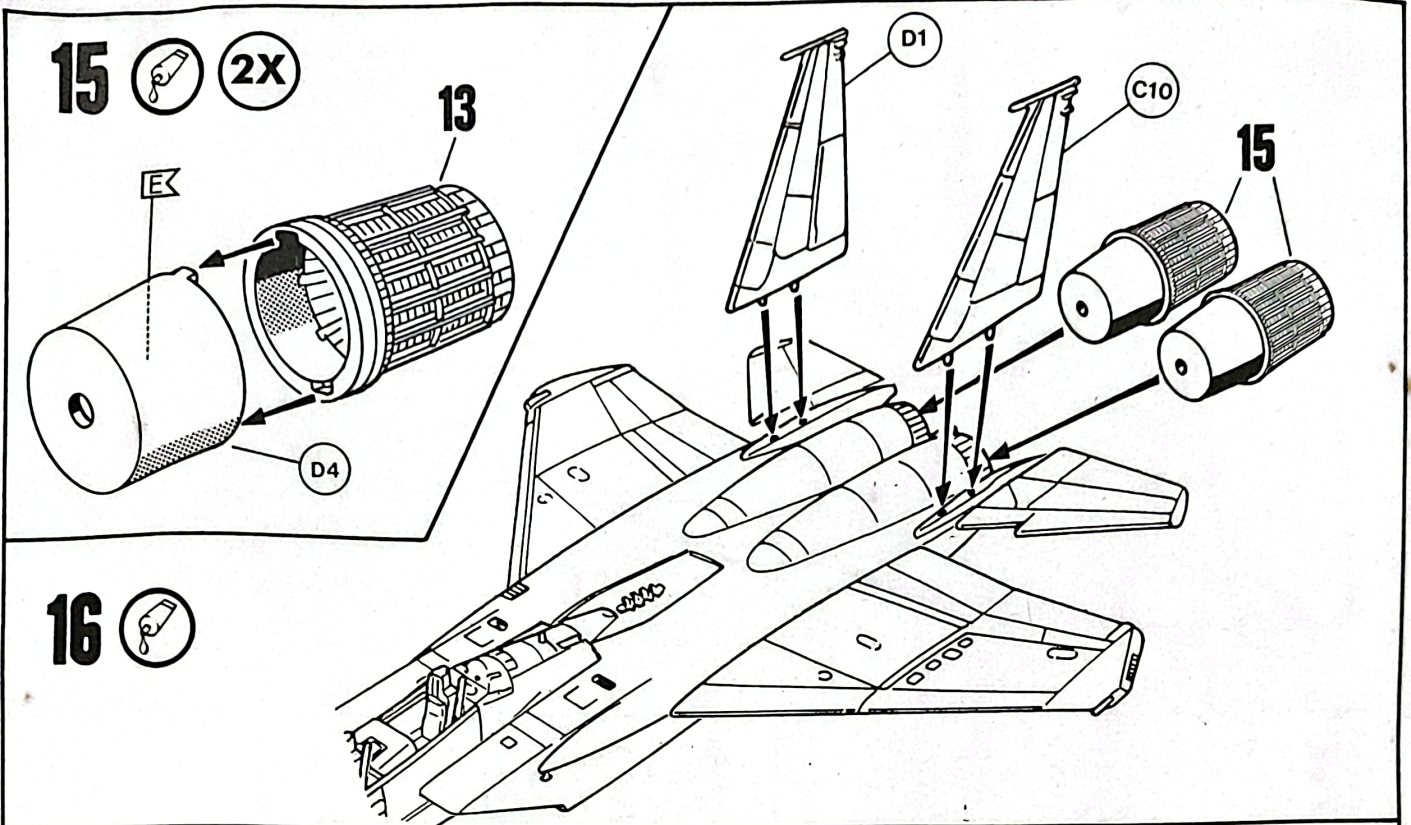



21 

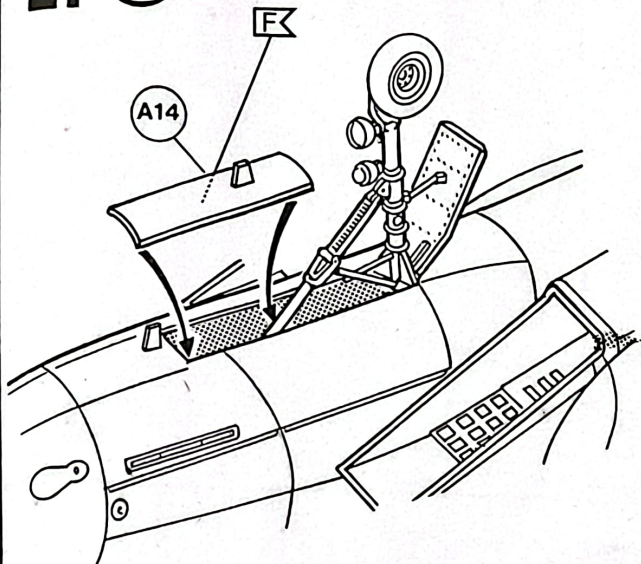

22 

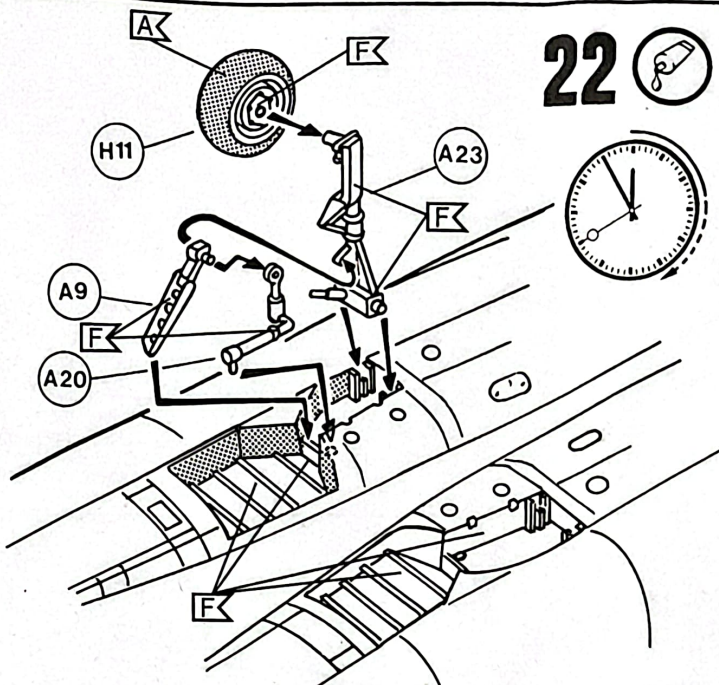

23 

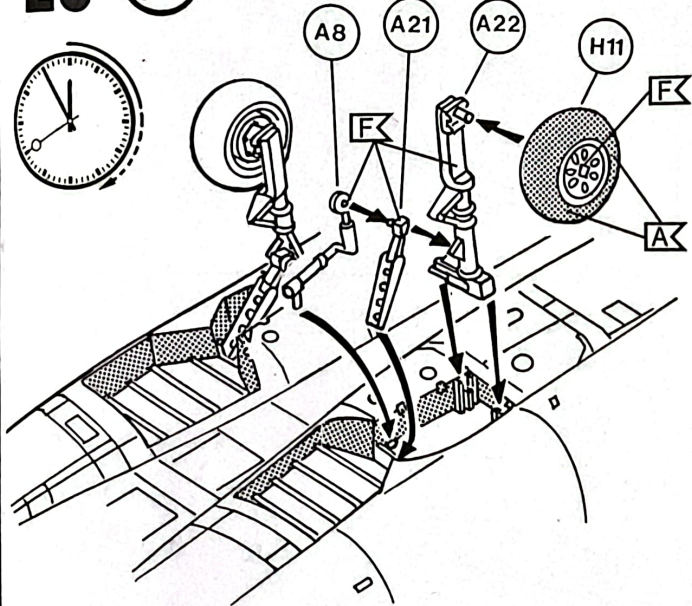

24 

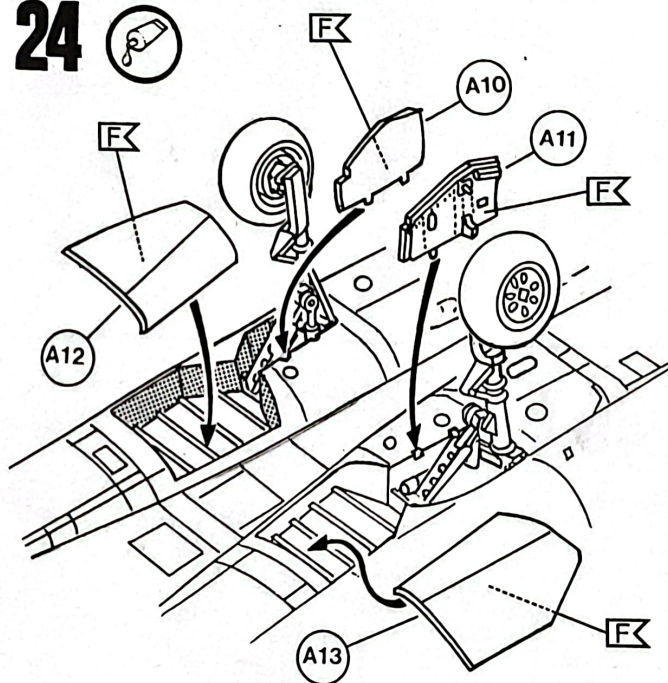



25 

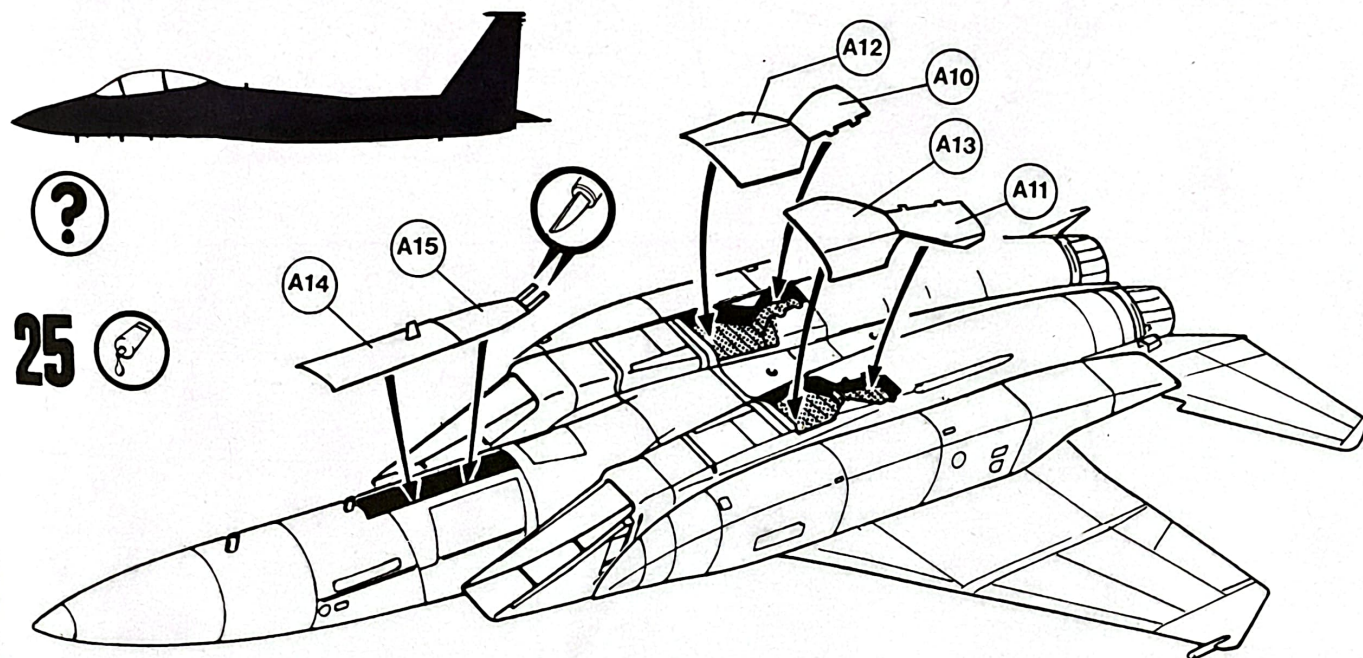

26



3X

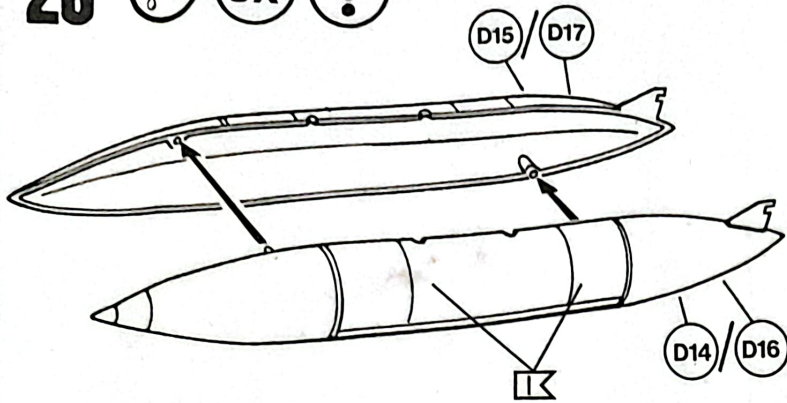

27



2X

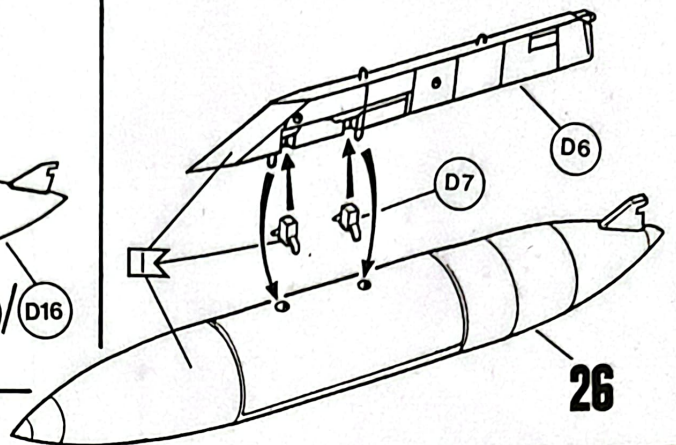

28

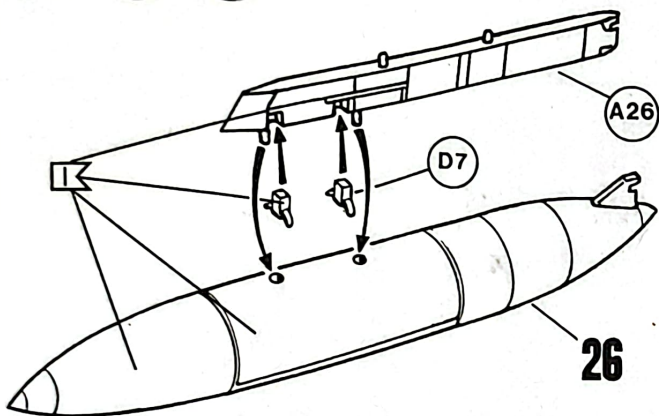

29



5X

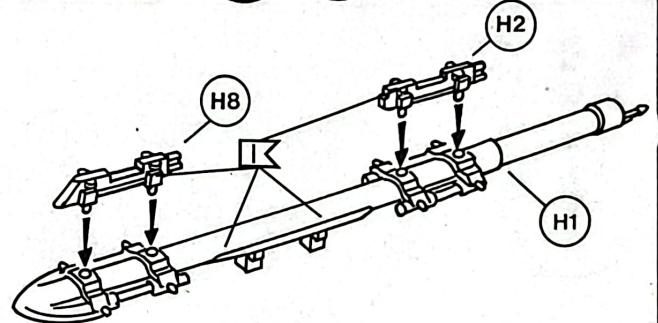

30



2X

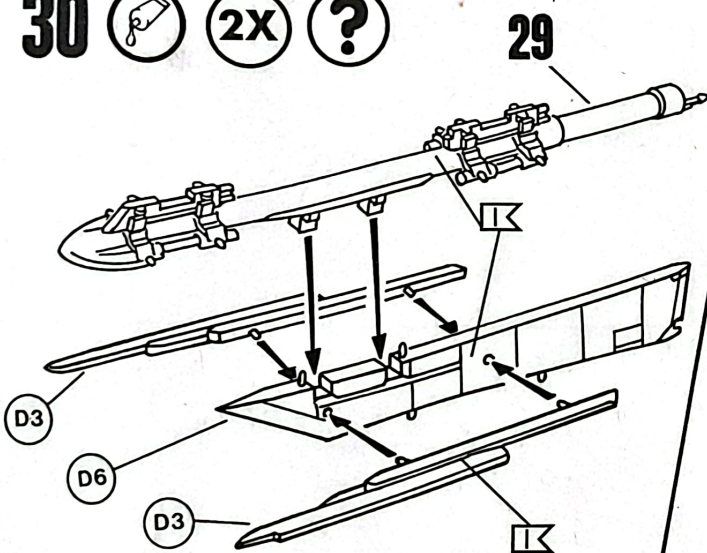

31

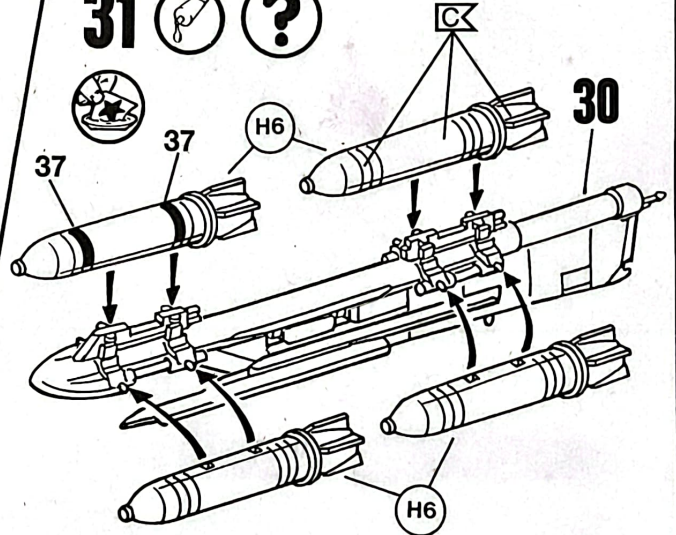

32



37

37



H6

H6

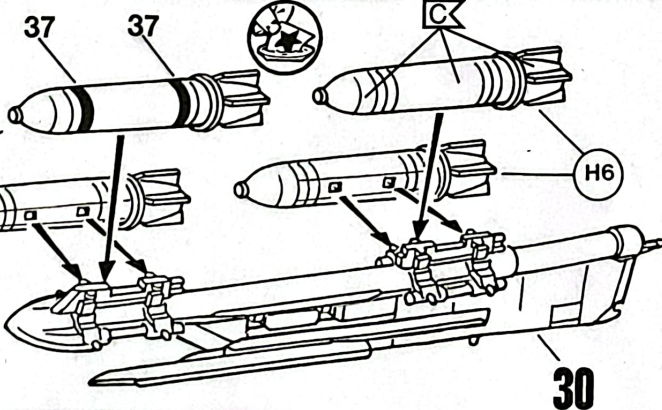

33

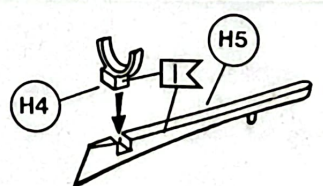

34

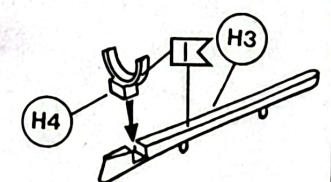

# 35

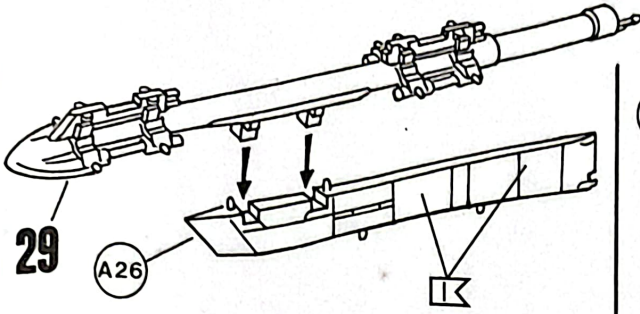

# 36

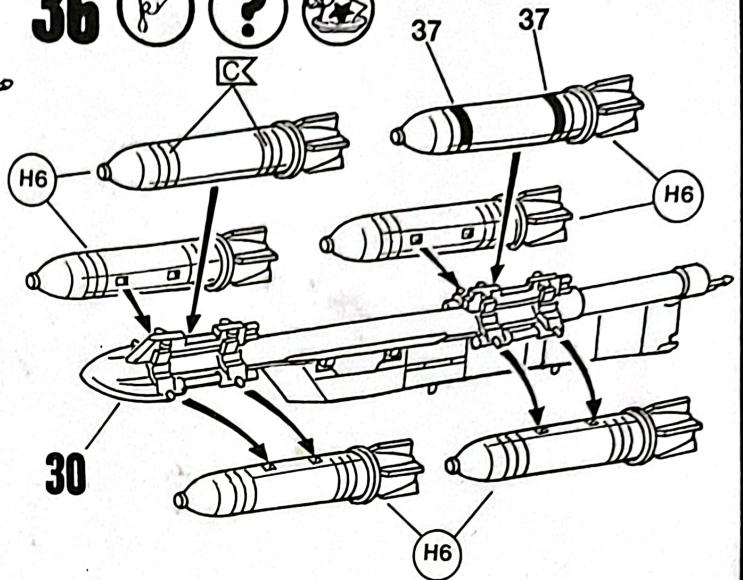

# 37

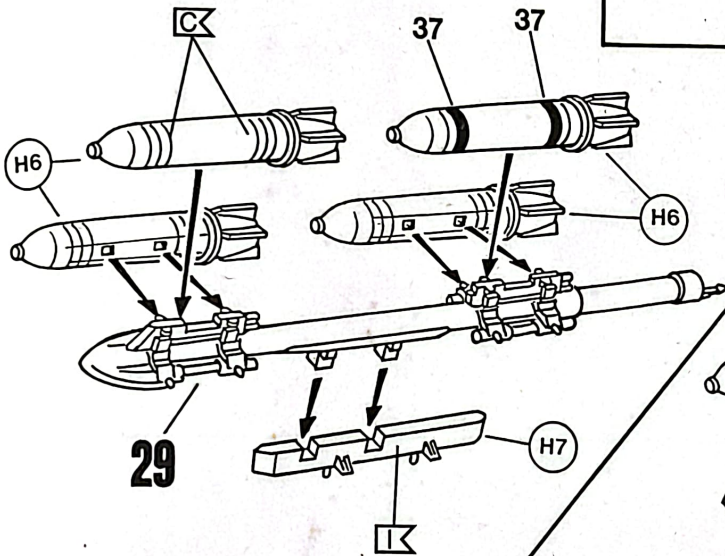

# 38

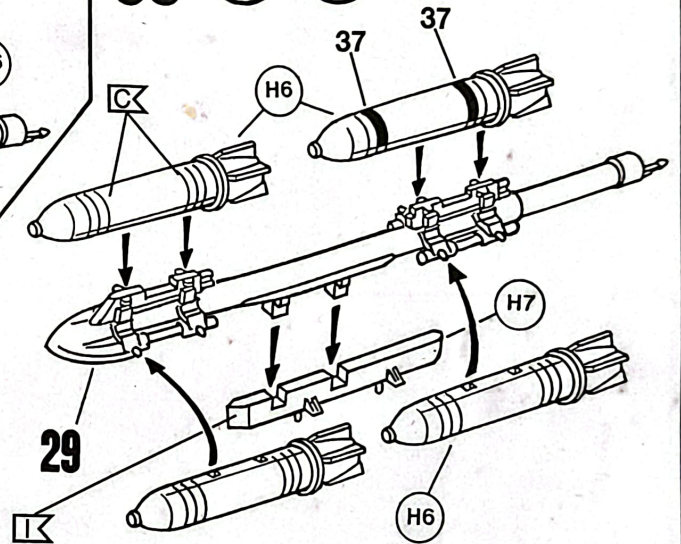

# 39

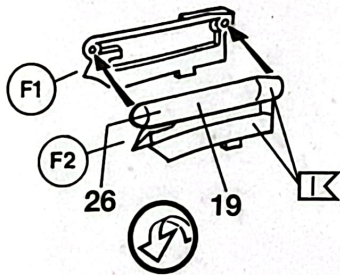

# 41

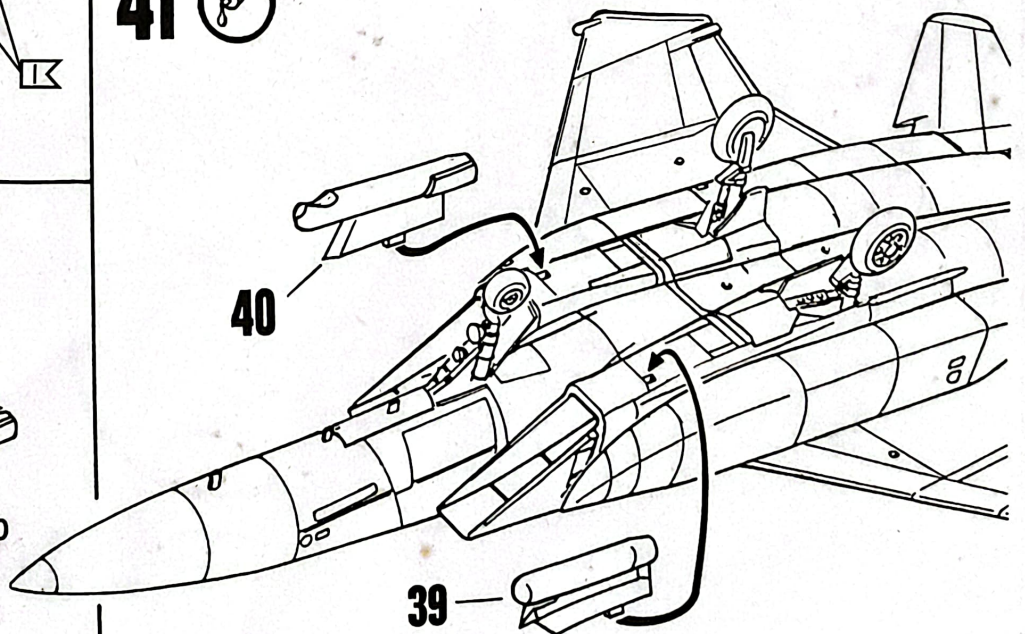

# 40

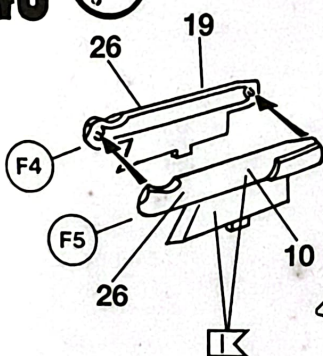

# 42

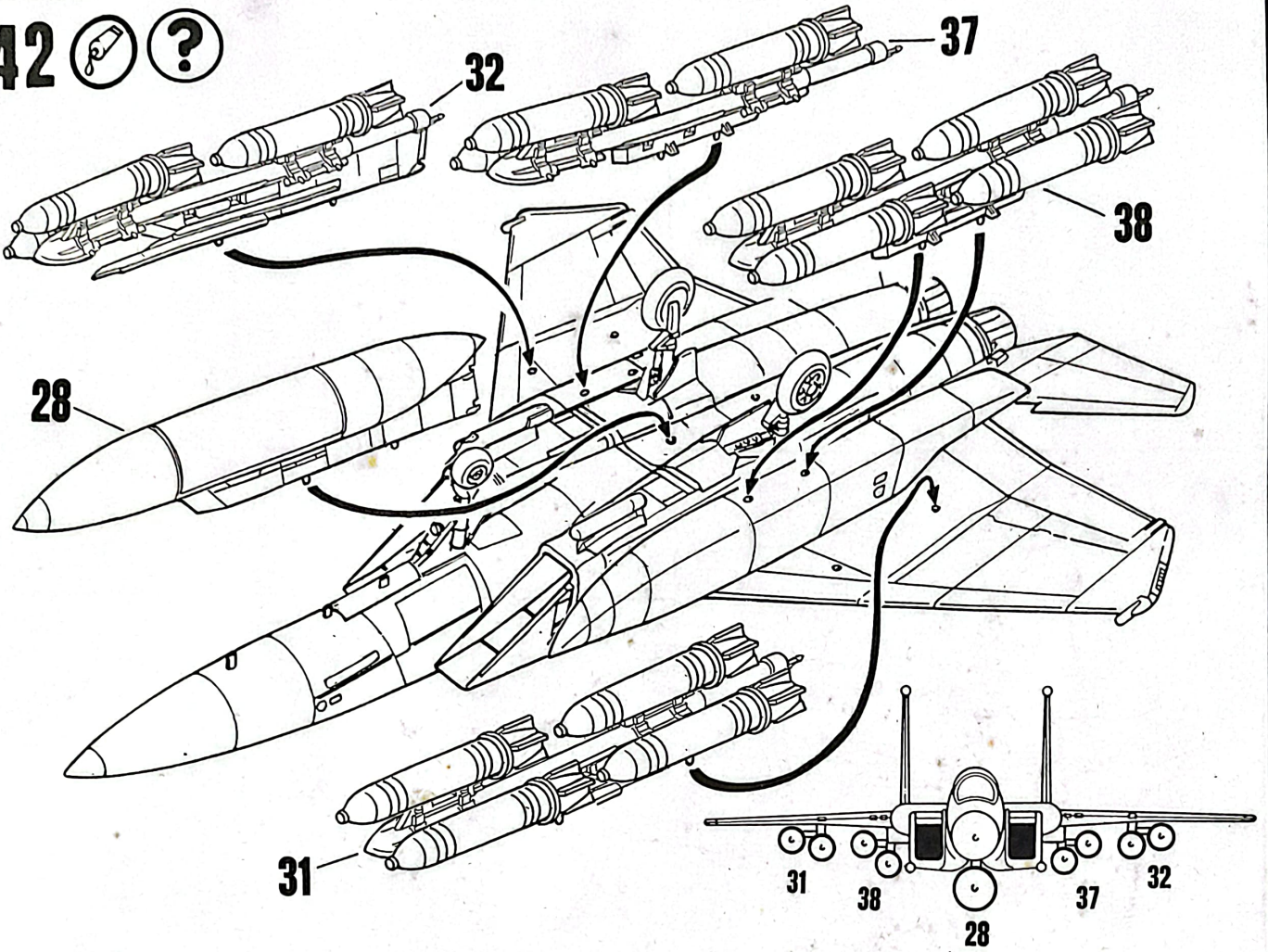

# 43

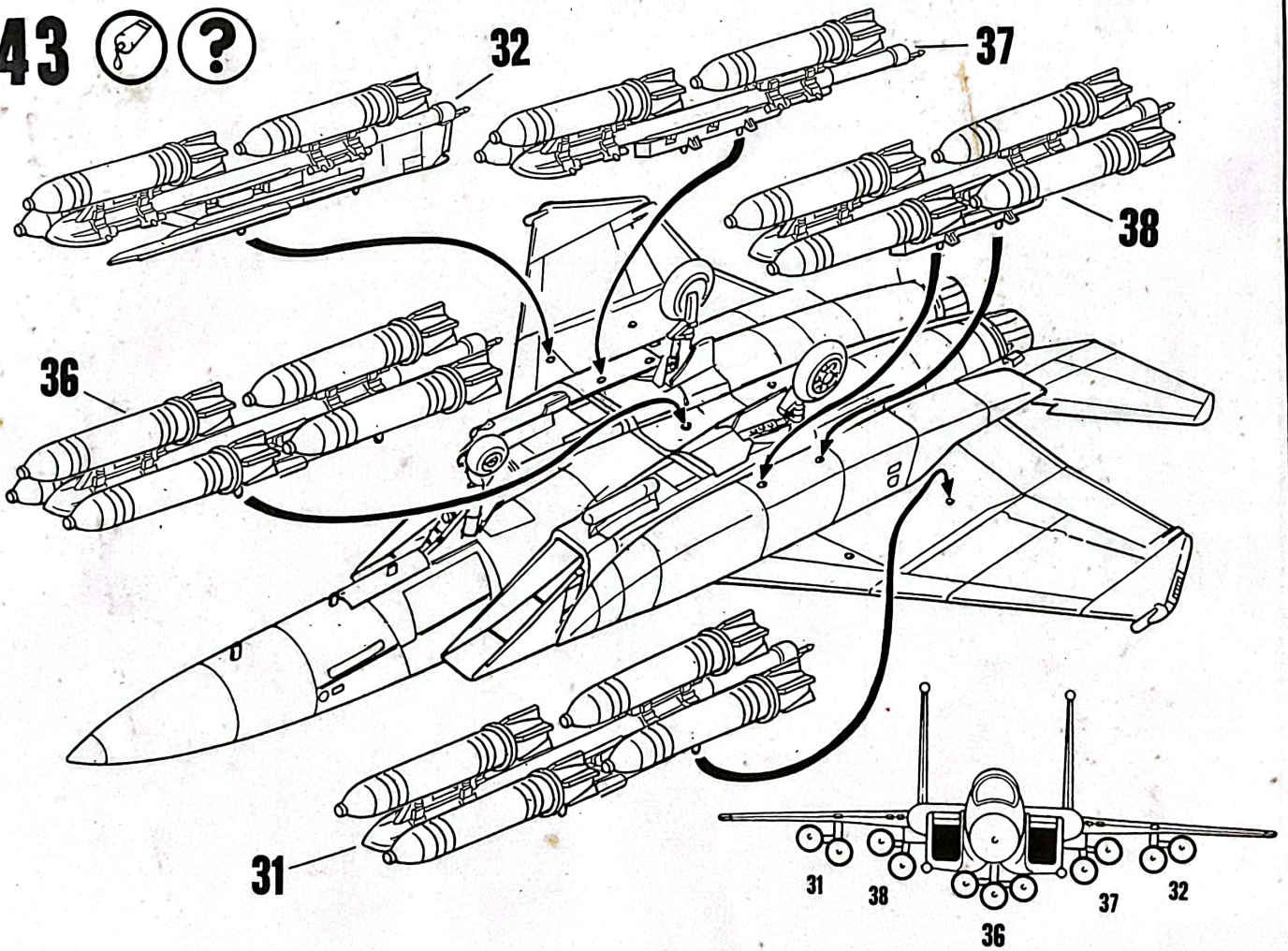

# 44

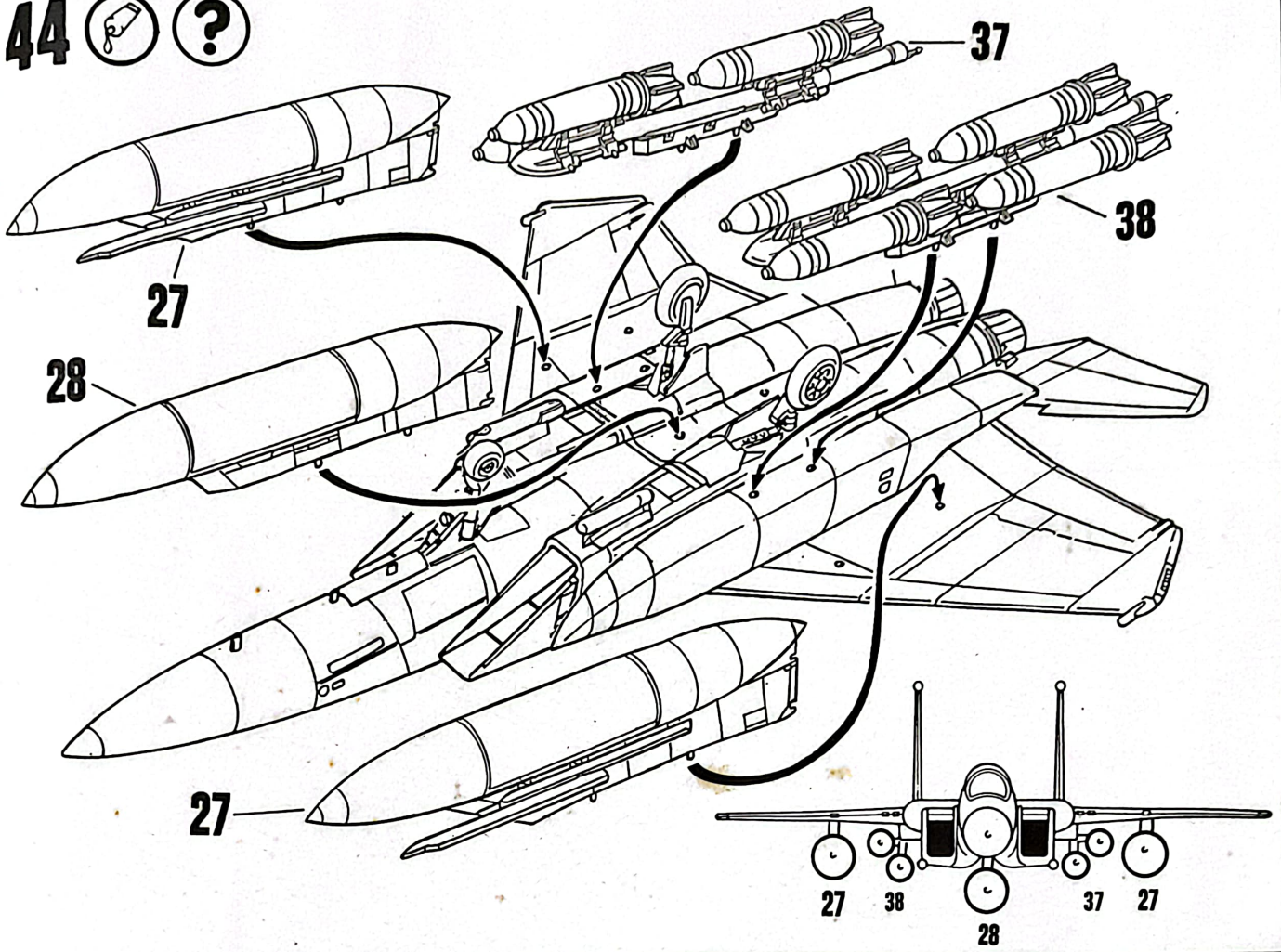

# 45

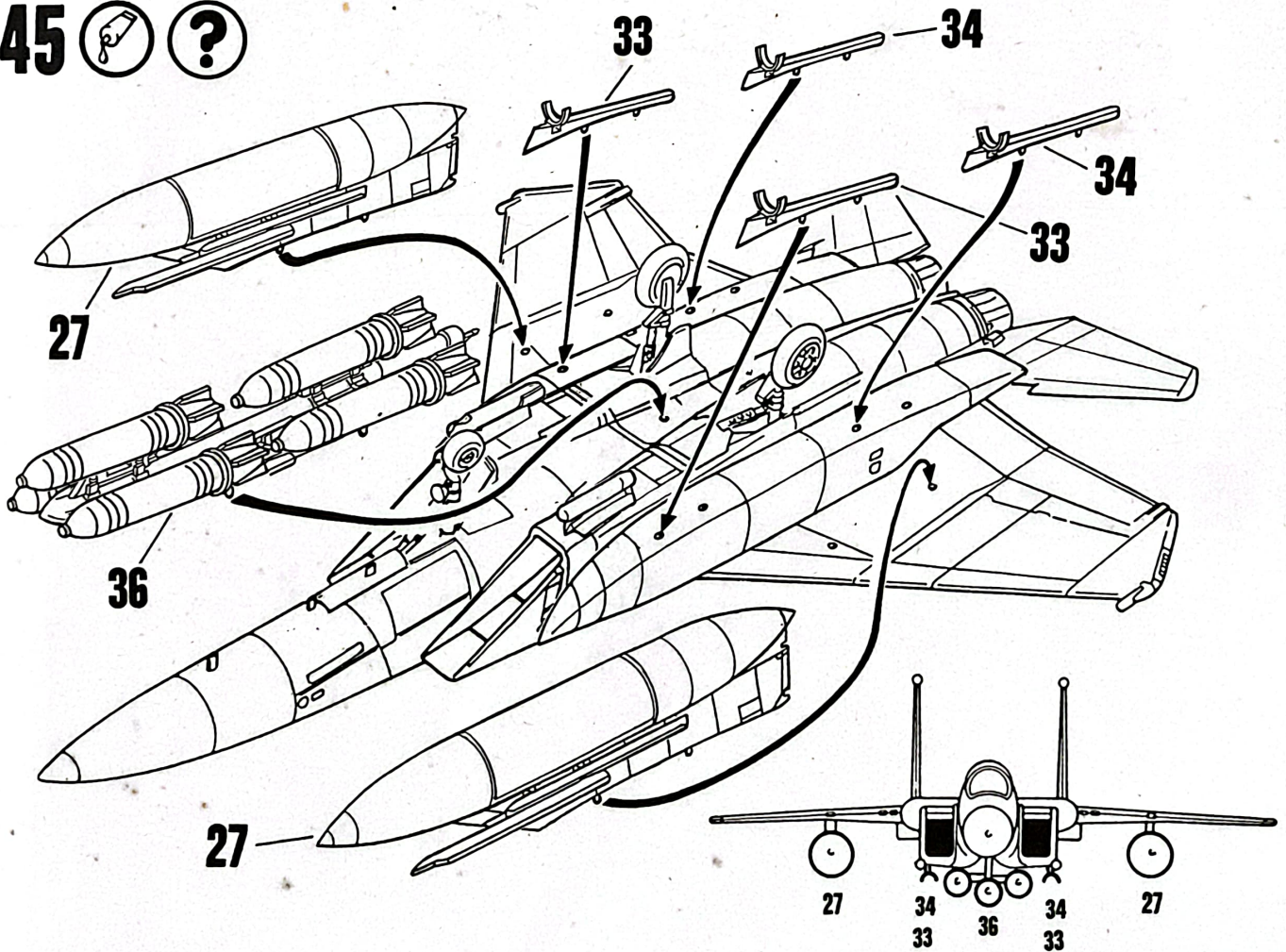

46

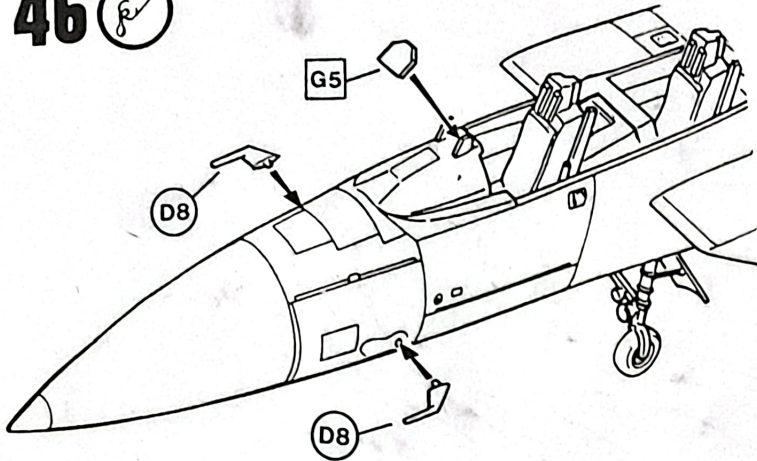

47

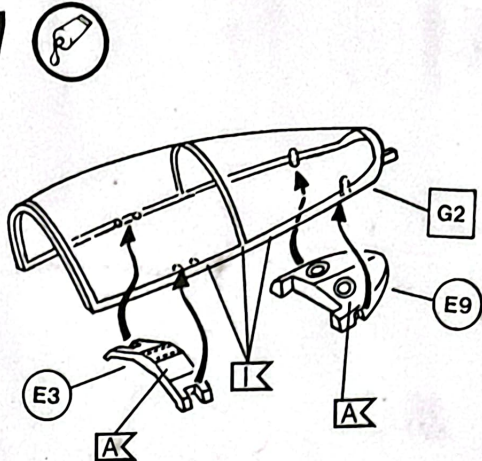

48

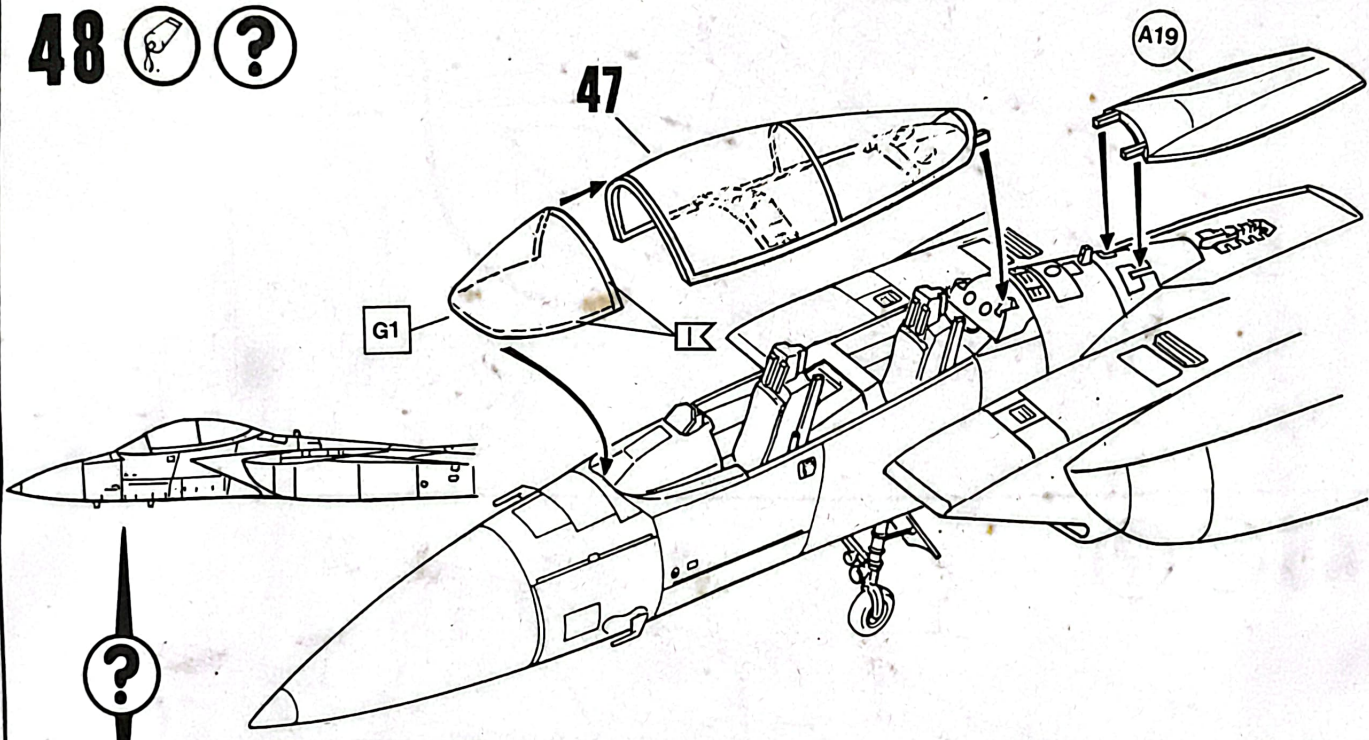

49

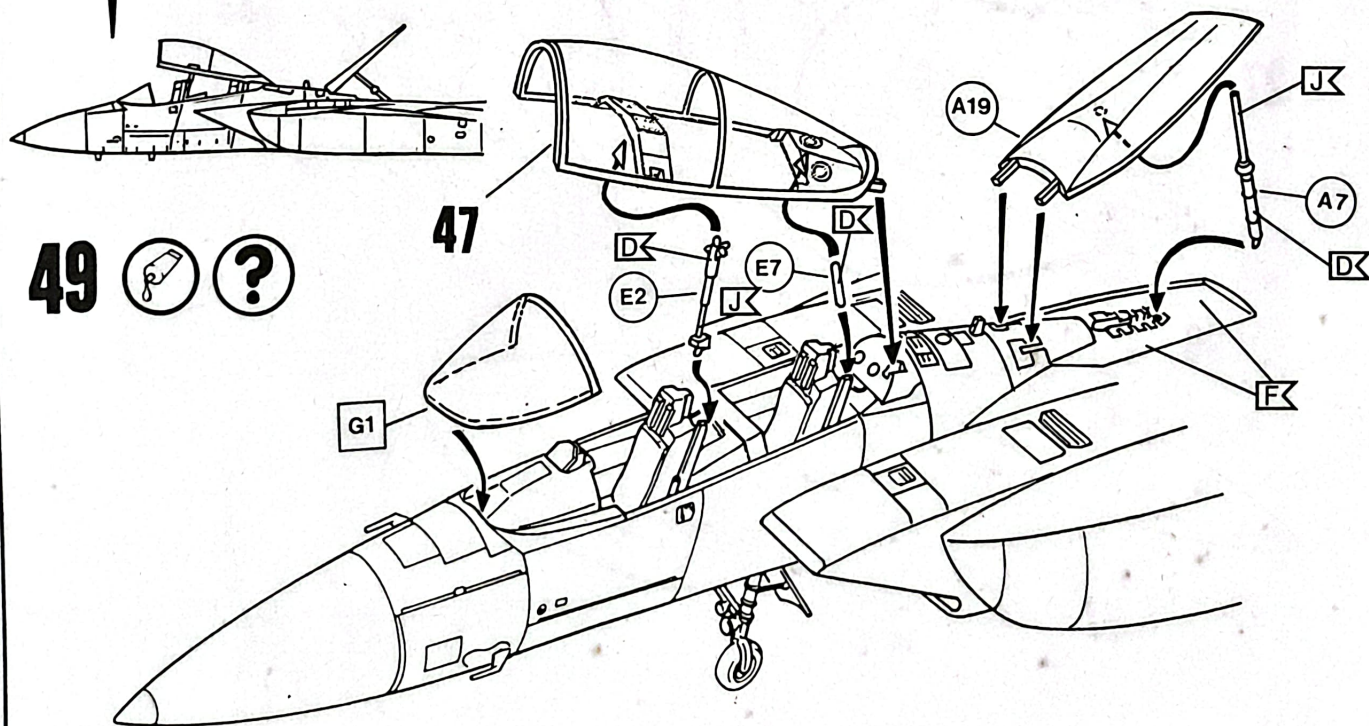

50

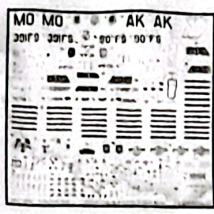

MDD F-15E-44-MC Strike Eagle  
Squadron Commander 391st. Fighter Squadron, 366th WG  
Mountain Home AB, Idaho U.S.A.

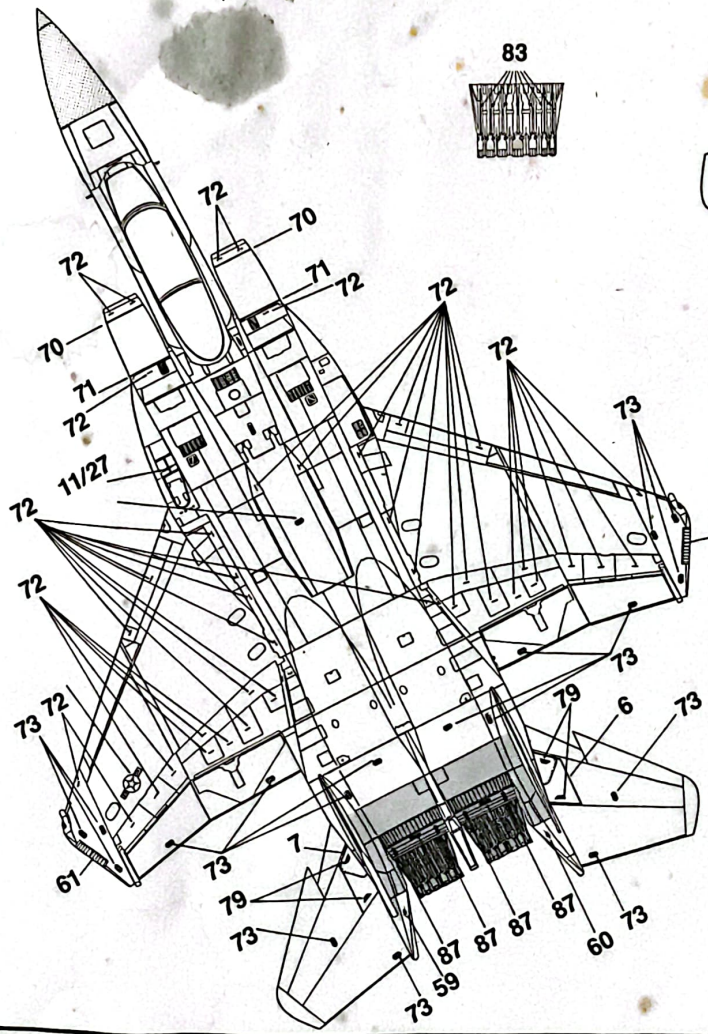
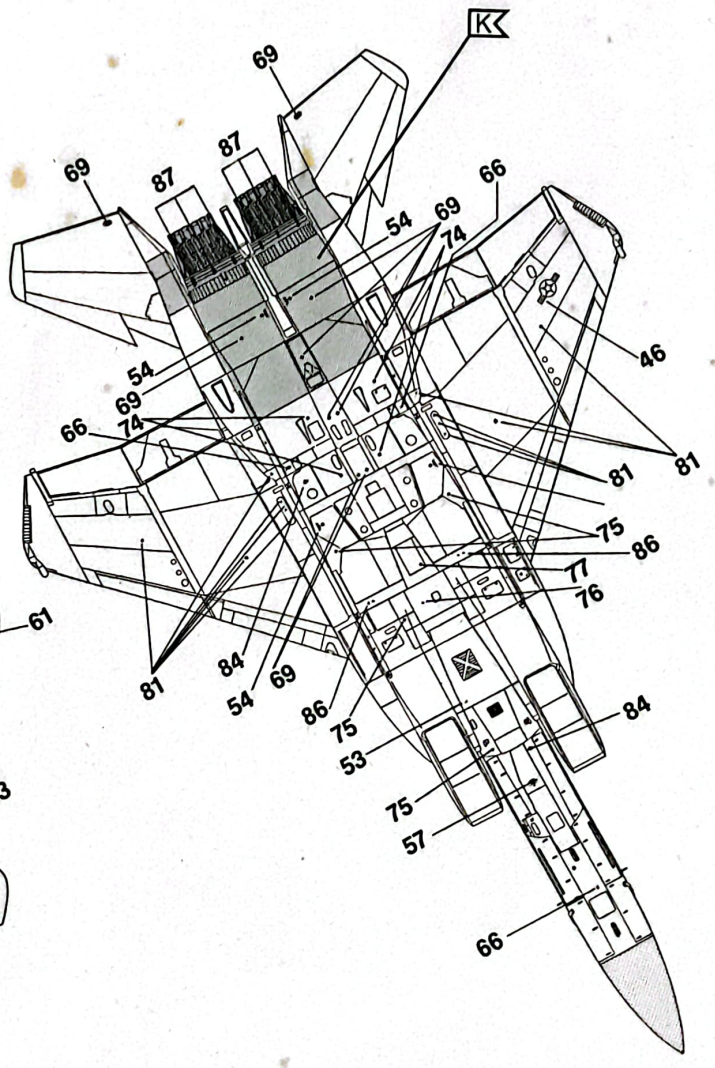
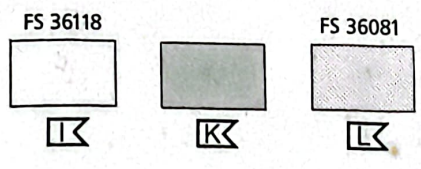
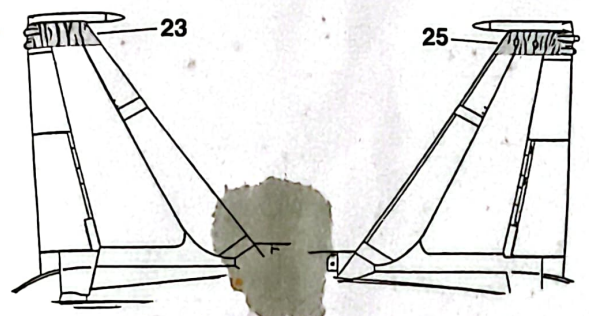
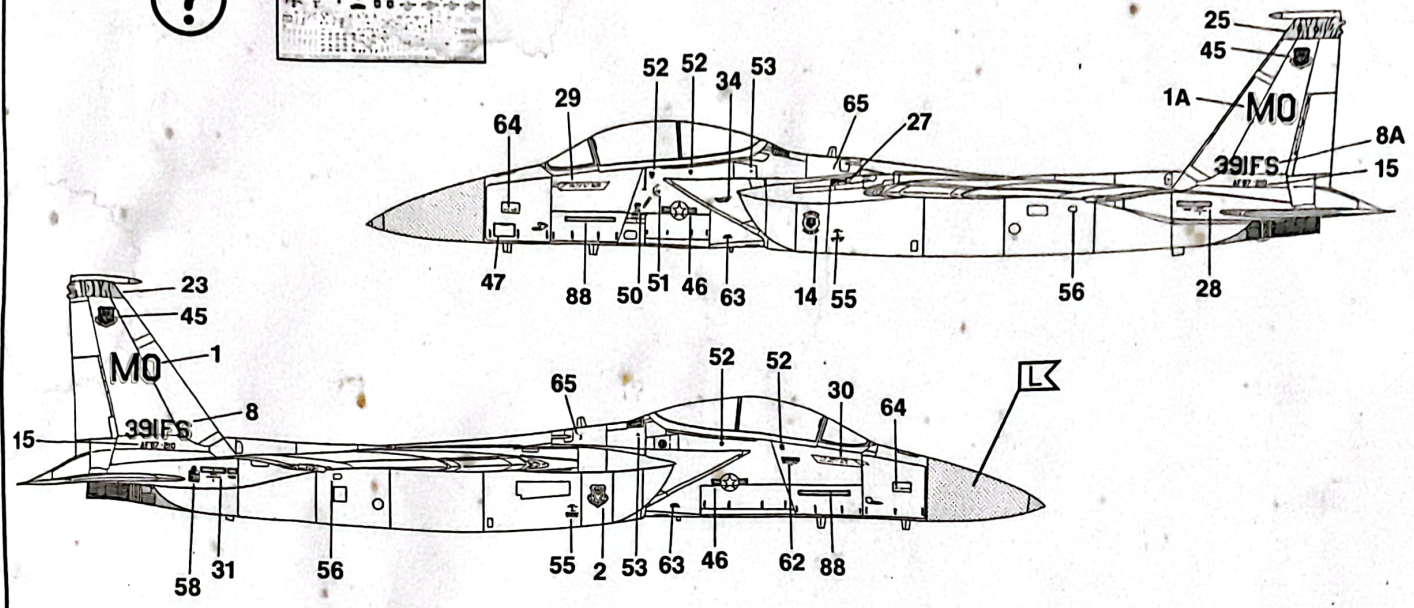

# 51

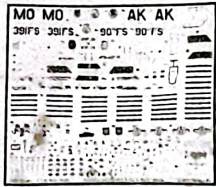

## MDD F-15E-49-MC Strike Eagle Squadron Commander 90th. Fighter Squadron, 3rd WG Elmendorf AB, Alaska U.S.A.

