

Plastic model kit containing 254 parts.

Wing span: 658 mm Length: 474 mm

1/48
SCALE



B-17G















Flying Fortress Early Production

The Boeing B-17 'Flying Fortress' was one of the U.S.A.'s main four-engine heavy bombers, operating alongside the B-24 Liberator, and the later B-29 Superfortress, in all theatres of World War 2. It's a fact that the B-17 almost never saw its place in history and the defeat of Nazi Germany, as the prototype, known as Model 299, crashed due to pilot error during its evaluation in October 1935. Thankfully, the design had shown such promise during the testing phase, in fact, far exceeding the requirements of the original specification, that further prototypes were ordered despite Boeing losing the original contract with the United States Army Air Corps. It was this further evaluation that saw the type enter active service in 1938. The actual name 'Flying Fortress' was coined by a newspaper hack who witnessed a roll-out of the machine, bristling with guns and turrets, and Boeing realised that this was the sort of propaganda they needed, and trademarked the name. After the initial prototypes, serial production of the B-17 began with the B-17B variant, and underwent a major revision with the introduction of the 'E'. This type featured a substantially redesigned tail and fillet that featured throughout subsequent versions, giving the B-17 its iconic profile. An extra 10ft of length was added to the fuselage. Other refinements included the addition of a tail and dorsal turret, and the addition of a Bendix turret to replace the fixed bathtub type that had

graced previous versions. This was found to be disappointing, and was eventually replaced with the Sperry ball turret that became a permanent feature of all future marques.

Boeing's 'G' incarnation of the Fort, was perhaps the most significant of all types built, and of course, numerous 'F' version modifications were carried over, such as the remotely operated Bendix chin turret that was introduced in the late block series of the 'F'. Differences between the 'G' version and the previous main production 'F' type were the positions of the nose cheek guns to accommodate the remote yolk for the Bendix turret operation, and for late block production of the 'G', the introduction of the Cheyenne tail gunner position which offered a reflector gun sight and much improved field of fire. Unlike the early production blocks of the 'G', the later production blocks introduced staggered waist gun positions for the flexible-mount .50-cal machine guns.

The B-17G was powered by 4 x Wright R-1820-97 "Cyclone" 1200hp turbocharged radial engines that were constantly uprated over the service life of the B-17, and it also carried 13 x .50cal M2 Browning machine guns. A typical long-range mission would see the B-17G carry around 4,500lbs of bombs. Wingspan was 103ft 9in, with a length of 74ft 4in. A crew of 10 was typically carried by all variants of the B-17G.

-  BE CAREFUL
-  REMOVE
-  GLUE TOGETHER
-  PLEASE WAIT FOR A FEW MINUTES UNTIL DRY
-  MAKE 2 PIECES
-  DRILL HOLE
-  DO NOT GLUE
-  INSTANT GLUE FOR METAL
-  BEND
-  FILL HOLE
-  SEQUENCE OF WORK
-  OPTIONAL
-  USED COLOUR
-  APPLY DECAL
-  MARKING OPTION

CAUTION

When using both glue and paint, do not use these near an open flame, due to the flammable properties of these items.

The symbols provided, such as 'X', refer to the basic colours of parts, although a more comprehensive list is supplied for your use for Tamiya, Mr Hobby and AK-Interactive codes.

When removing parts from sprues, take extreme care. Consider correct tools such as Xuron Sprue Cutters

Please check the symbology on the left and familiarise yourself before building this model kit.

In cooperation with:



www.ak-interactive.com



Large Scale Modeller

www.largescalemodeller.com

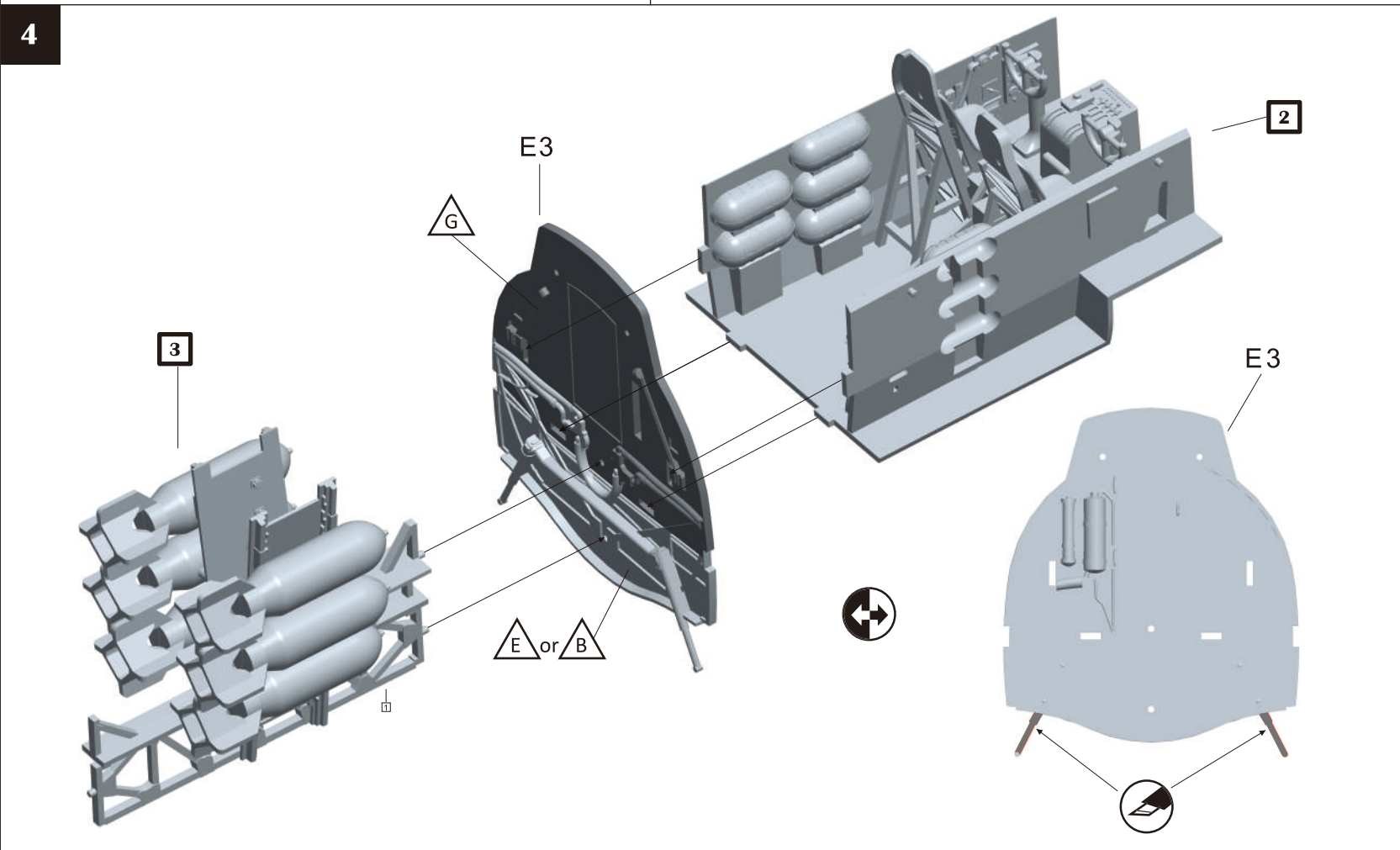
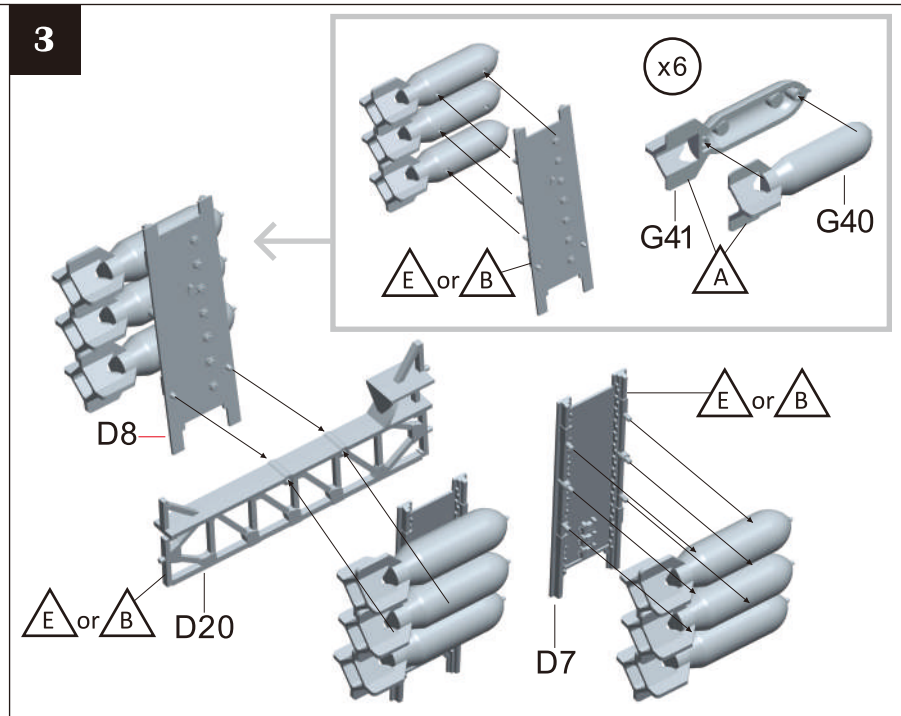
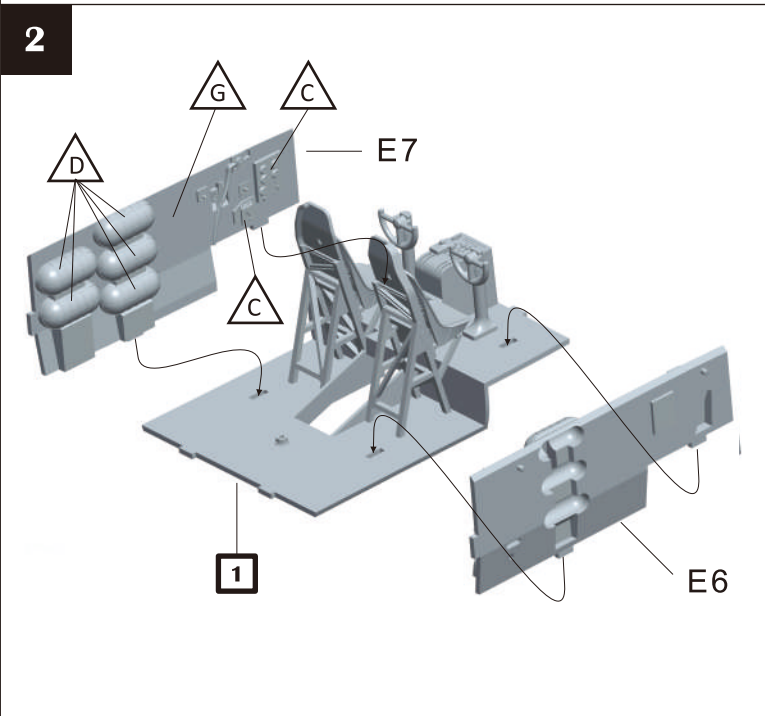
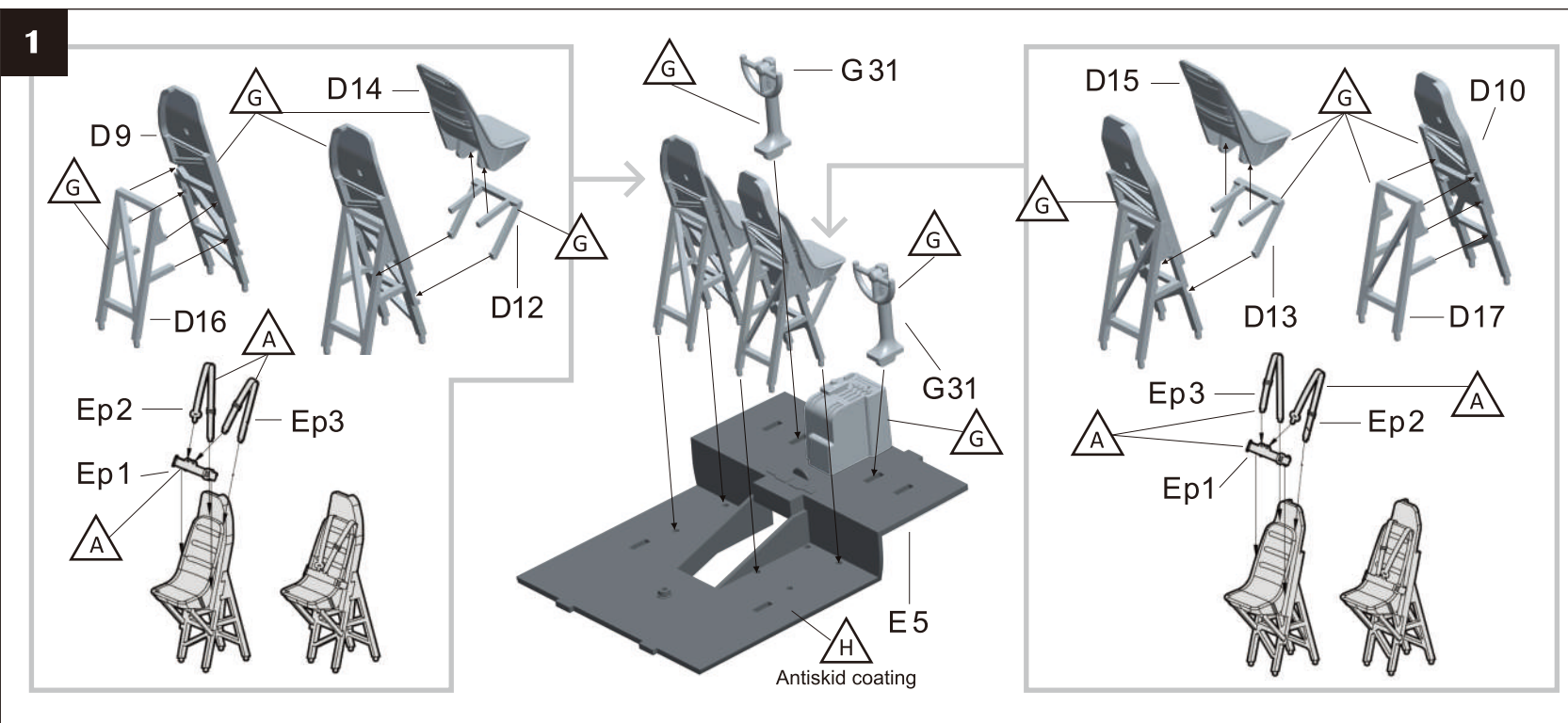

5

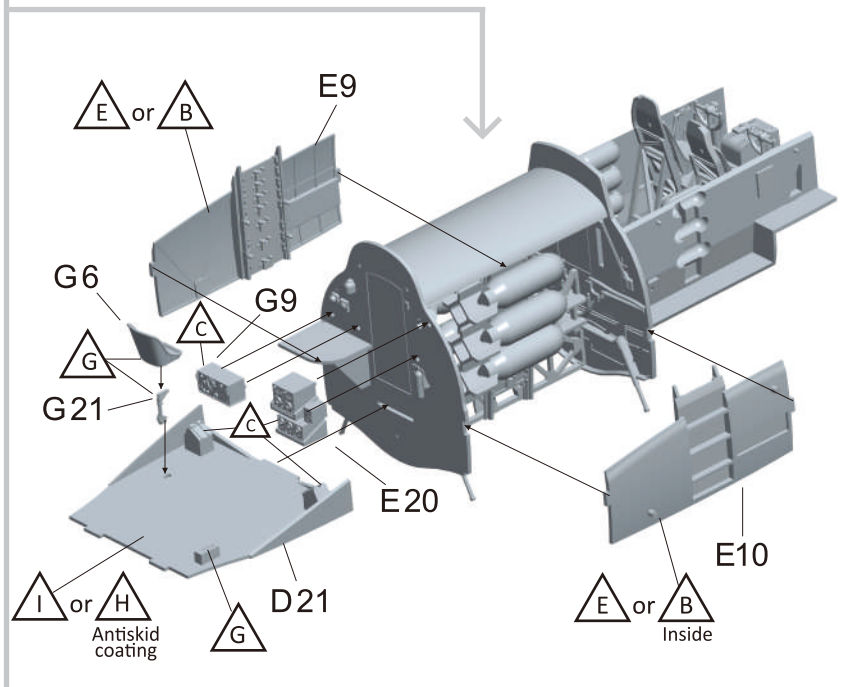
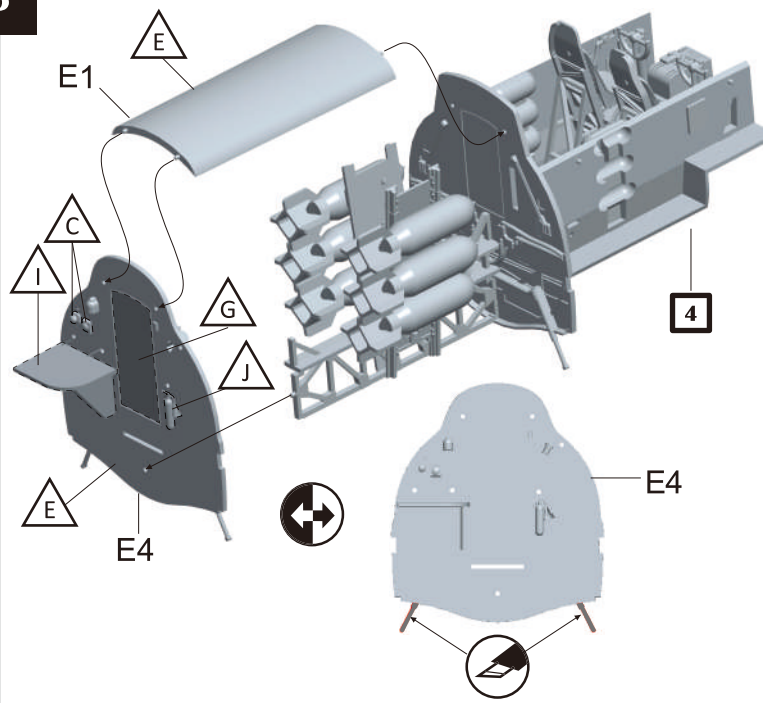

6

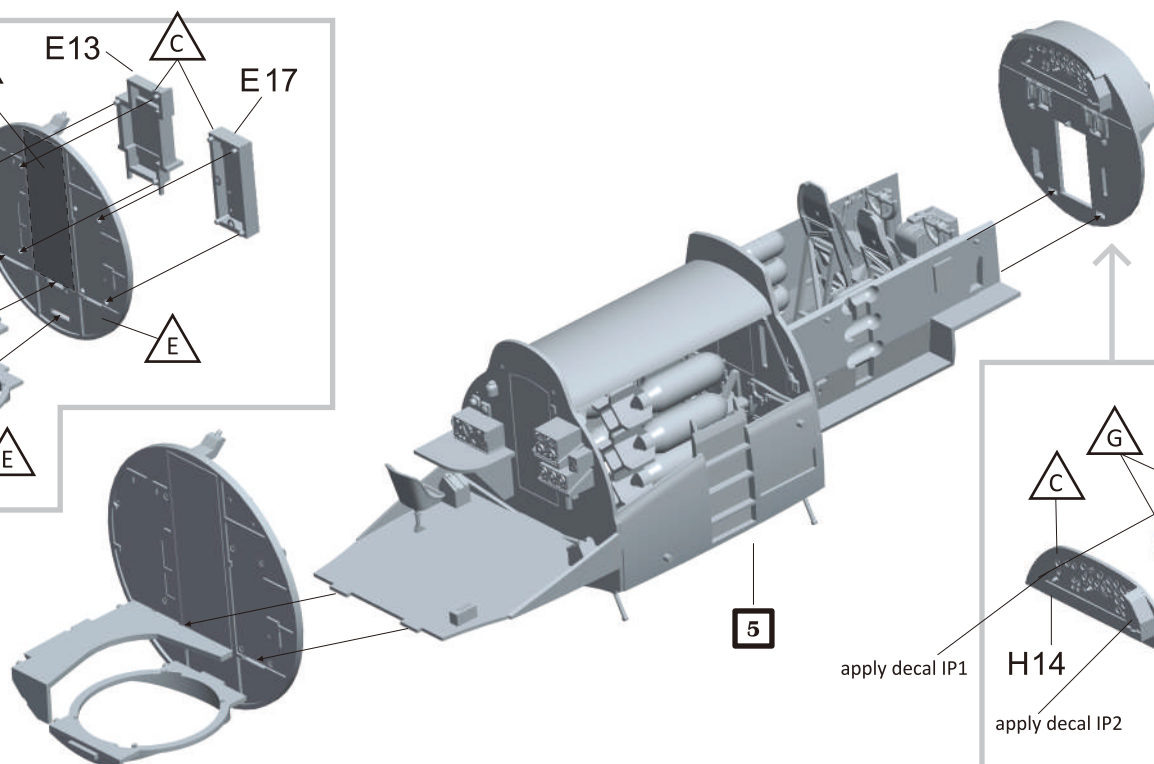
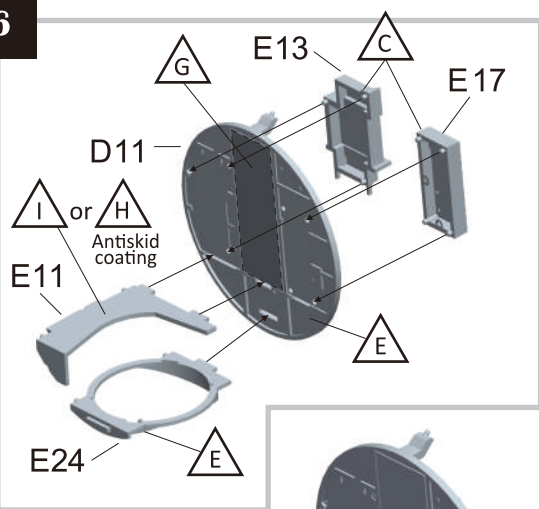

7

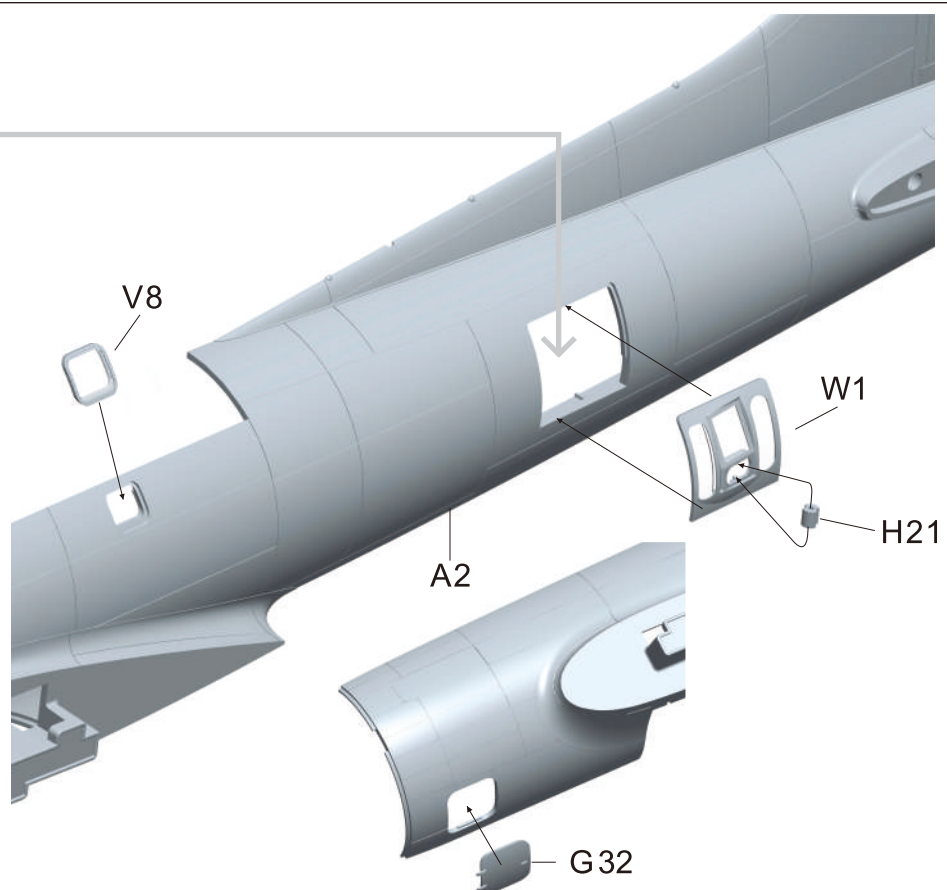
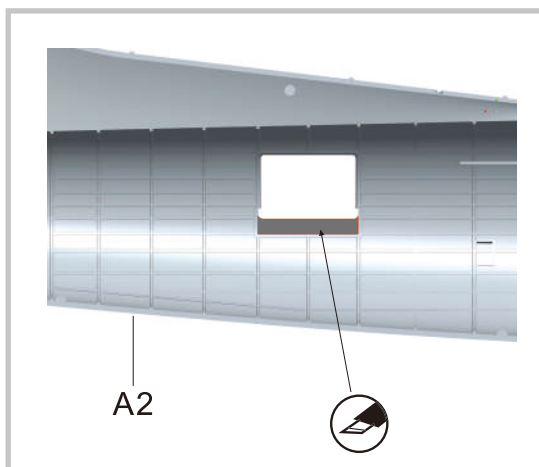

8

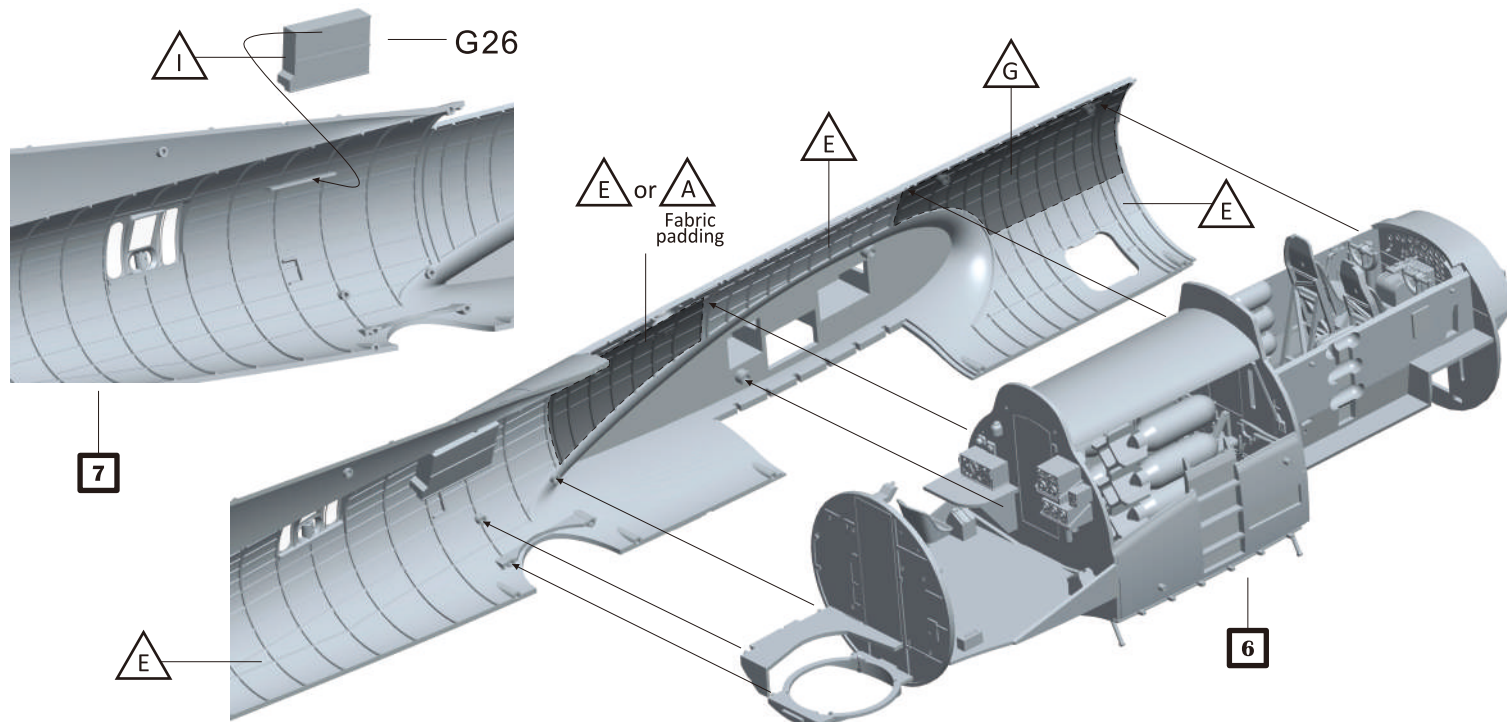

9

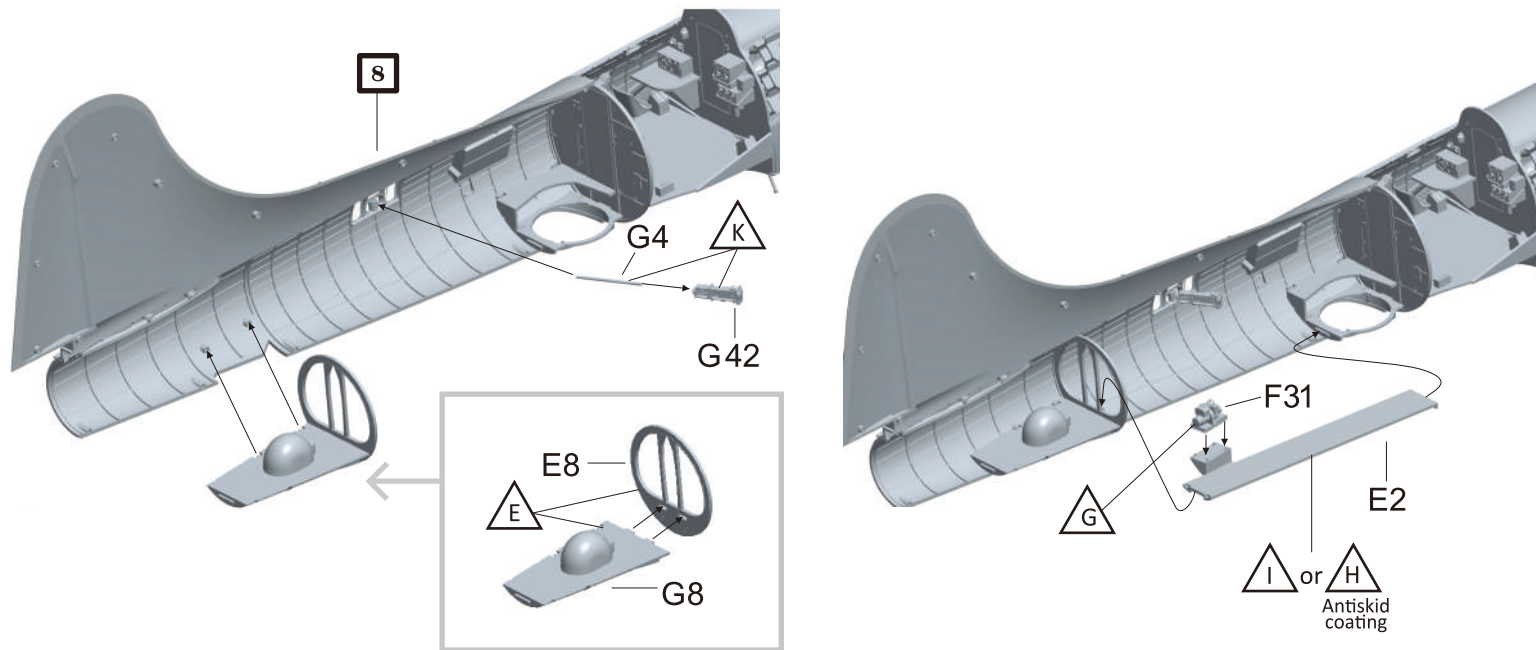

10

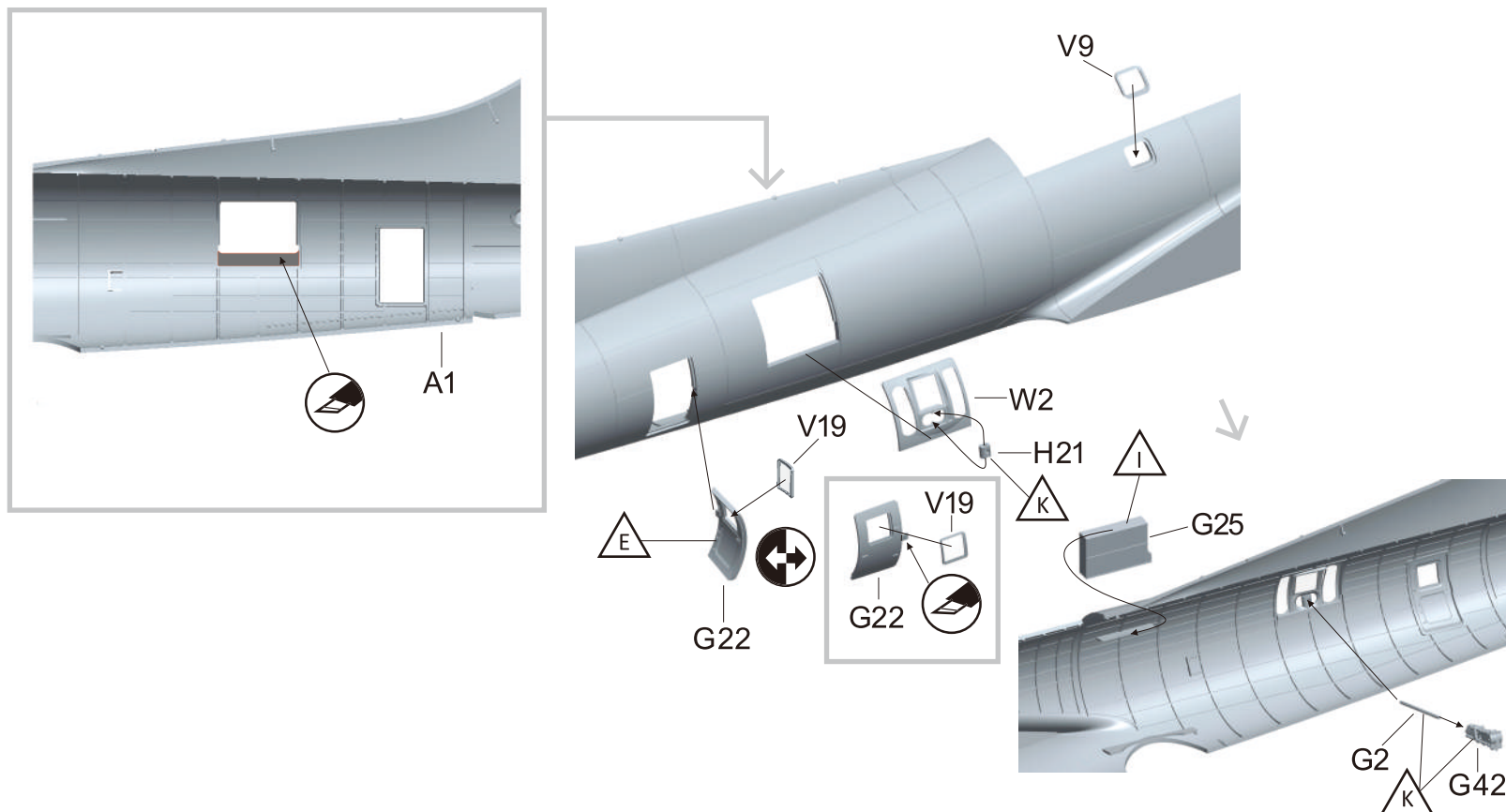

11

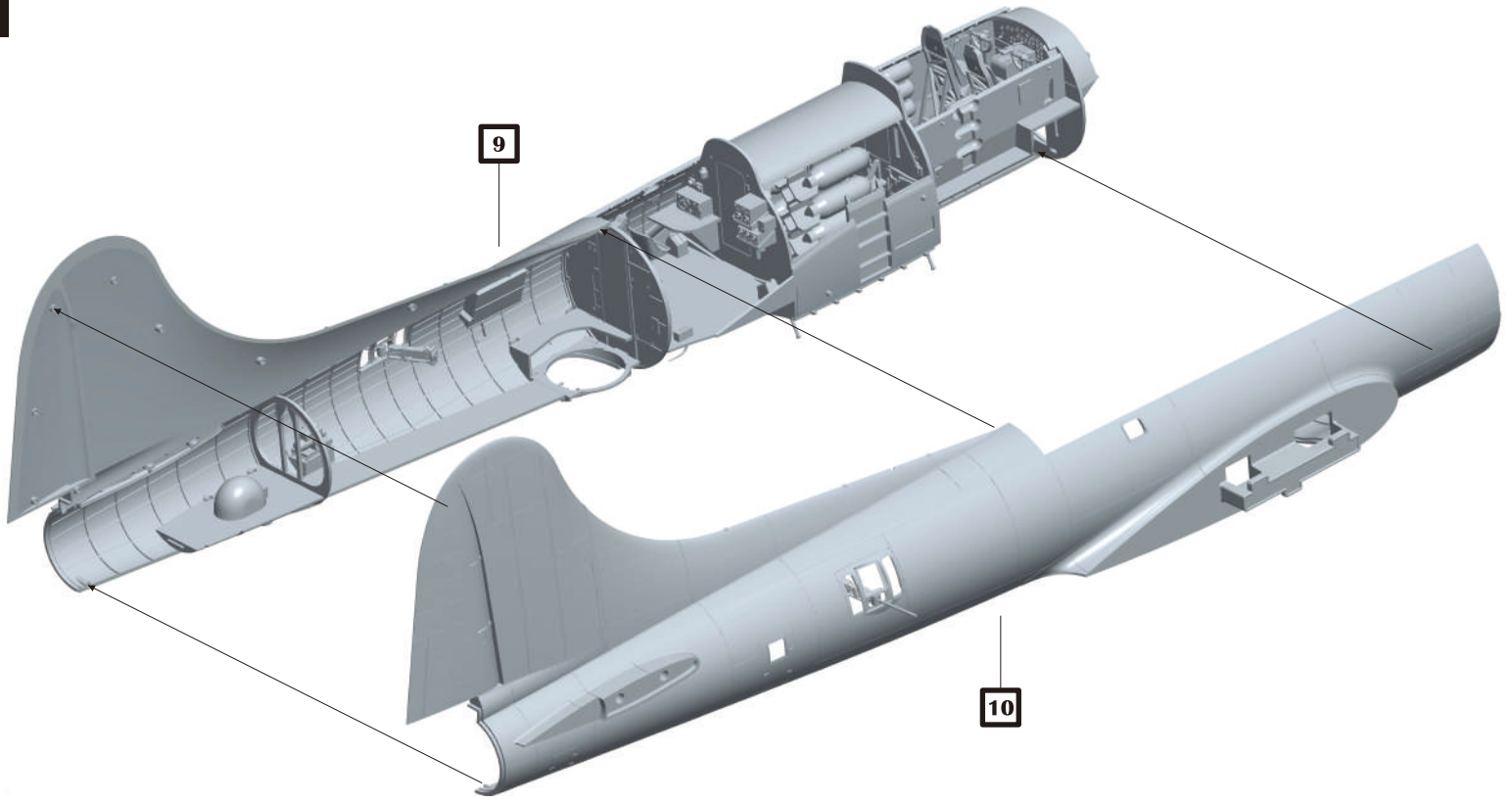

12

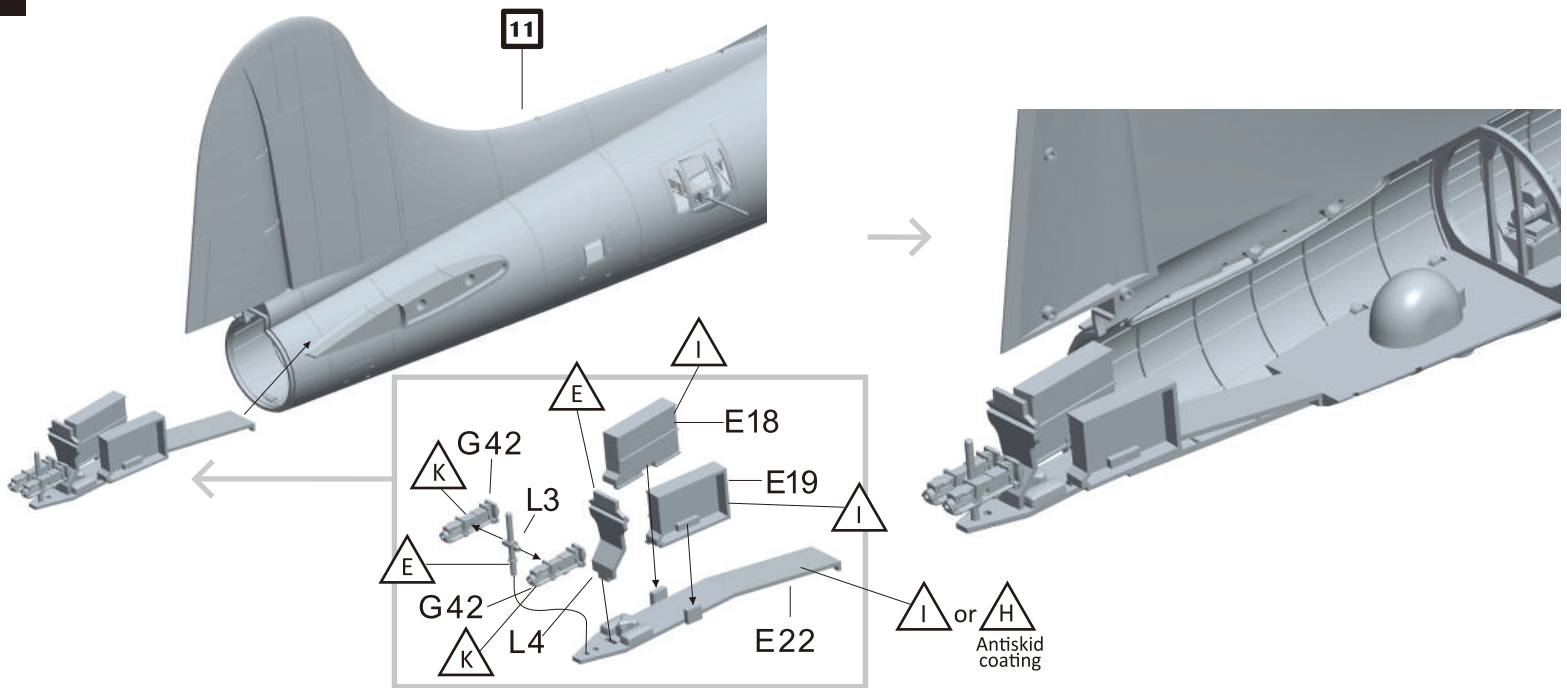

13

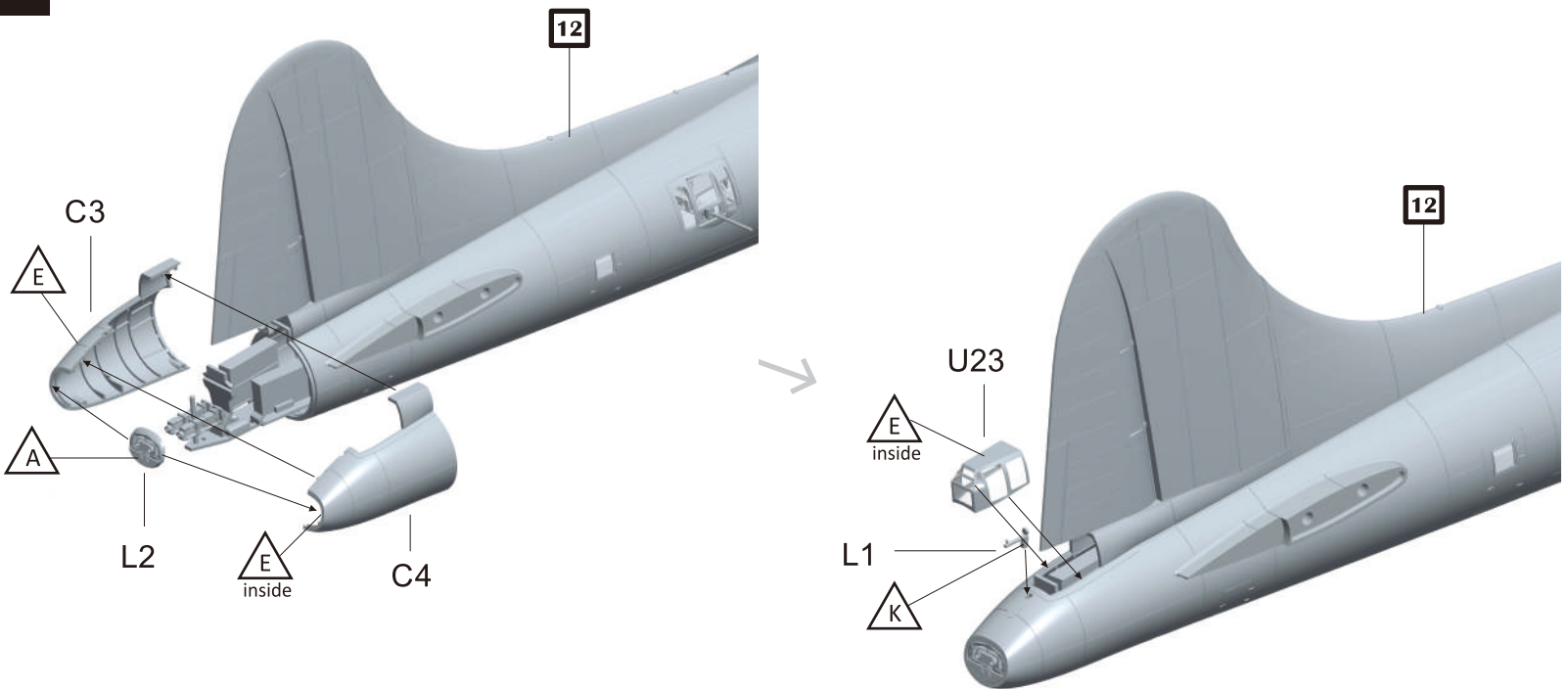

14

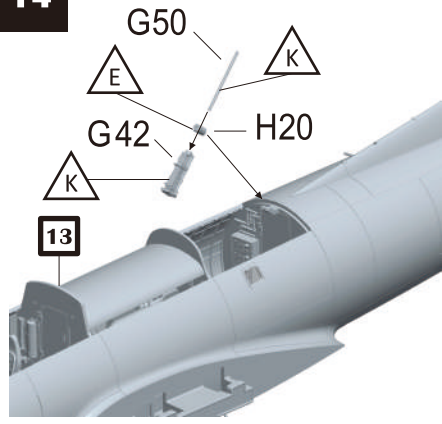

15

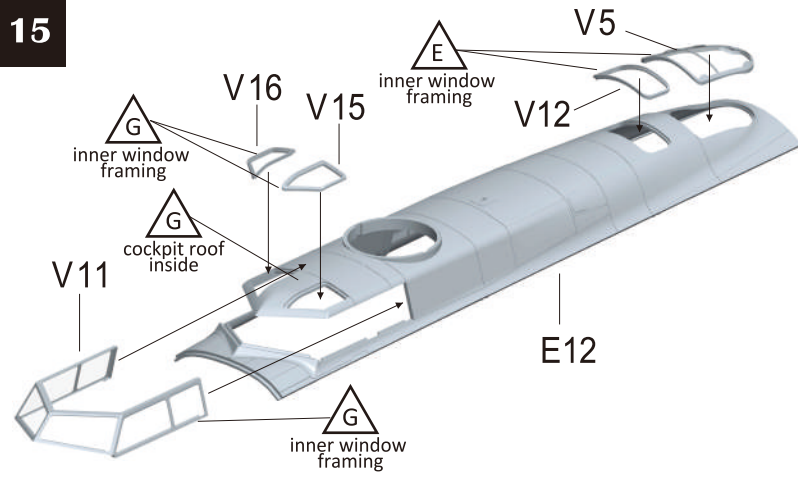

16

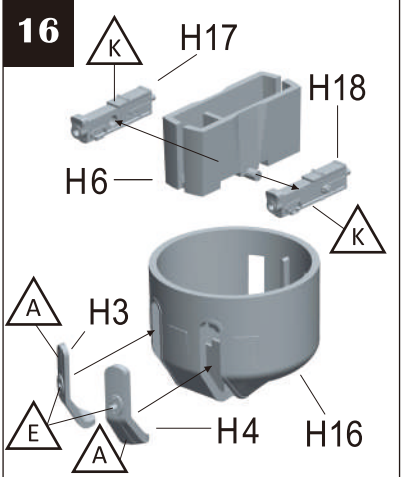

17

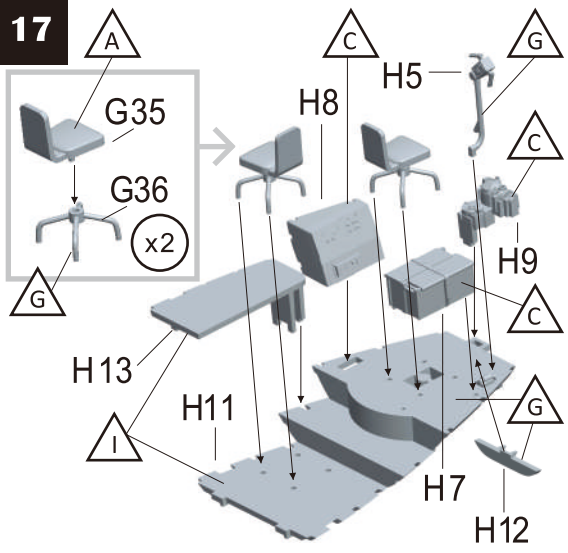

18

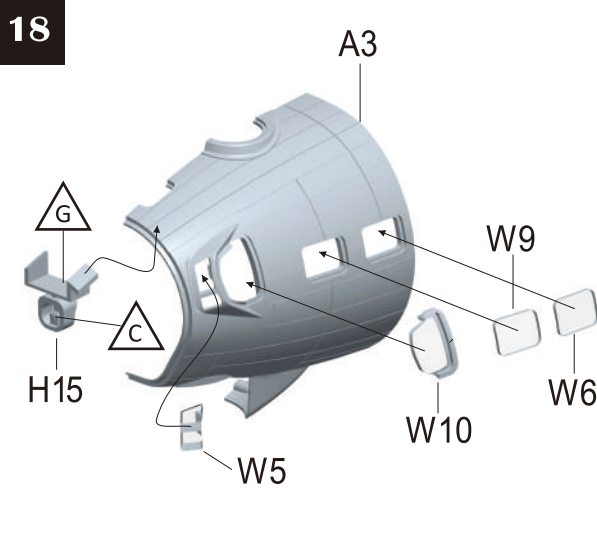

19

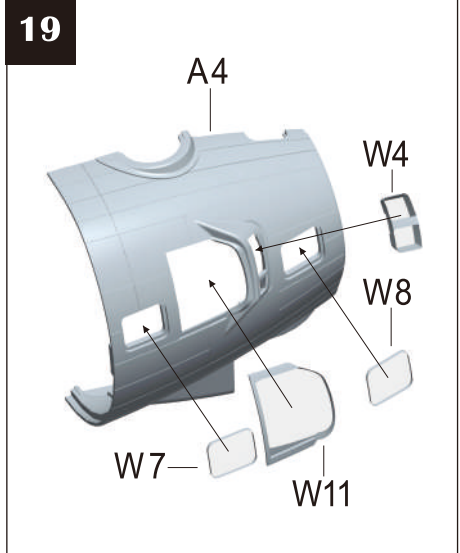

20

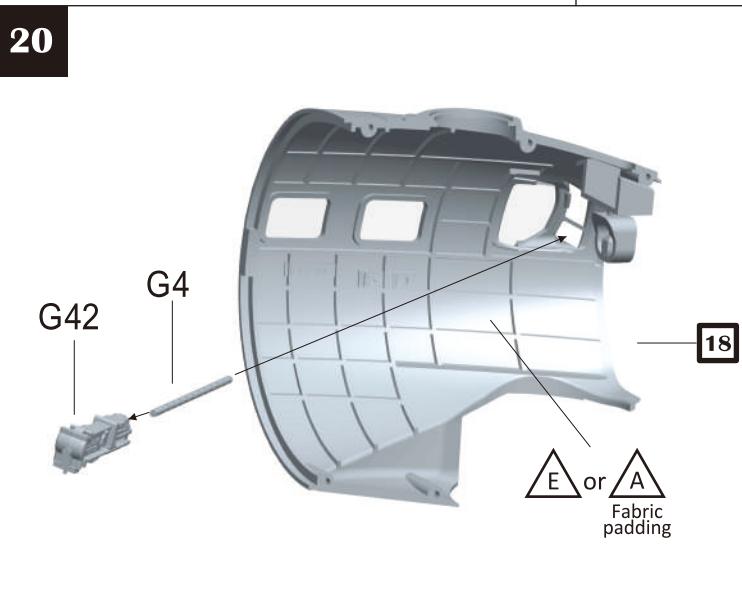

21

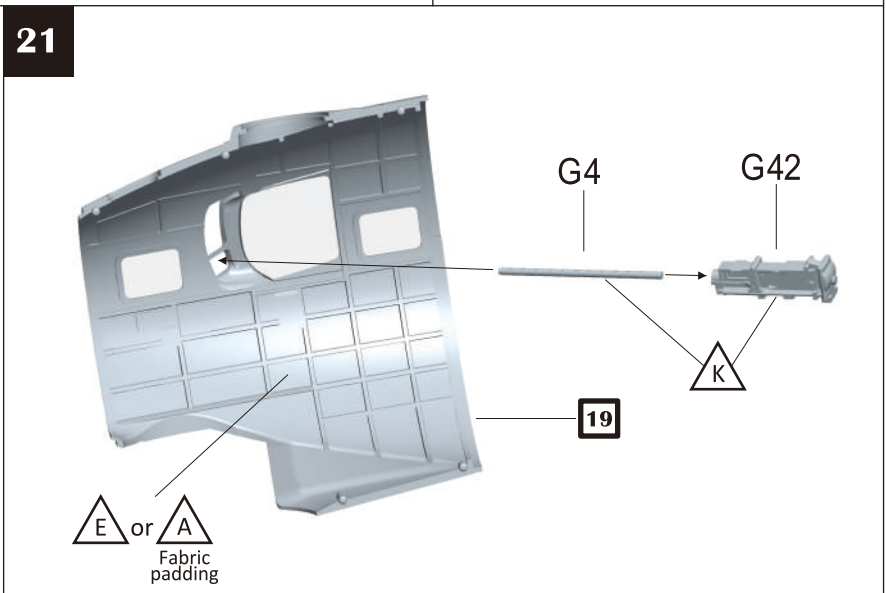

22

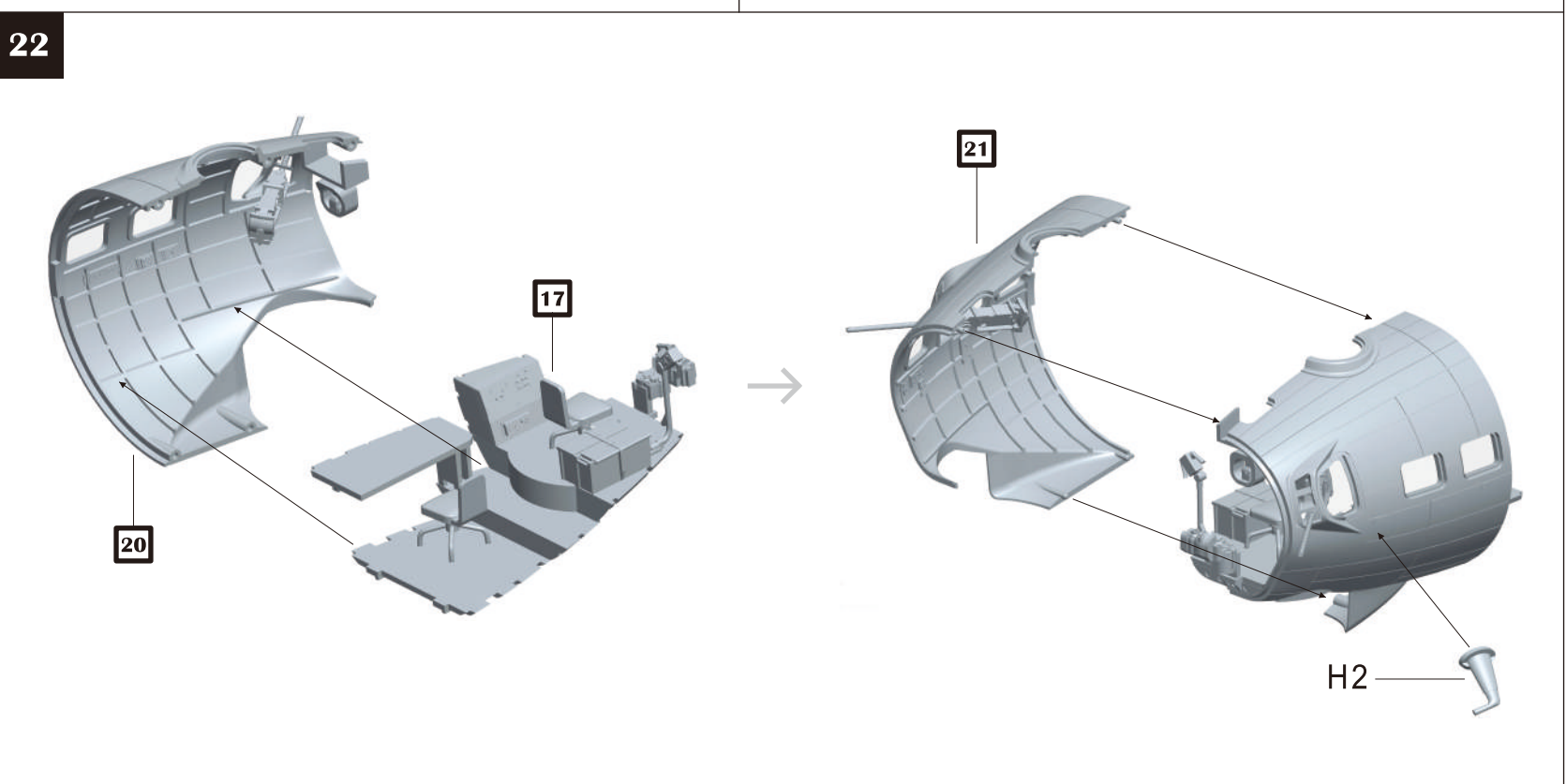

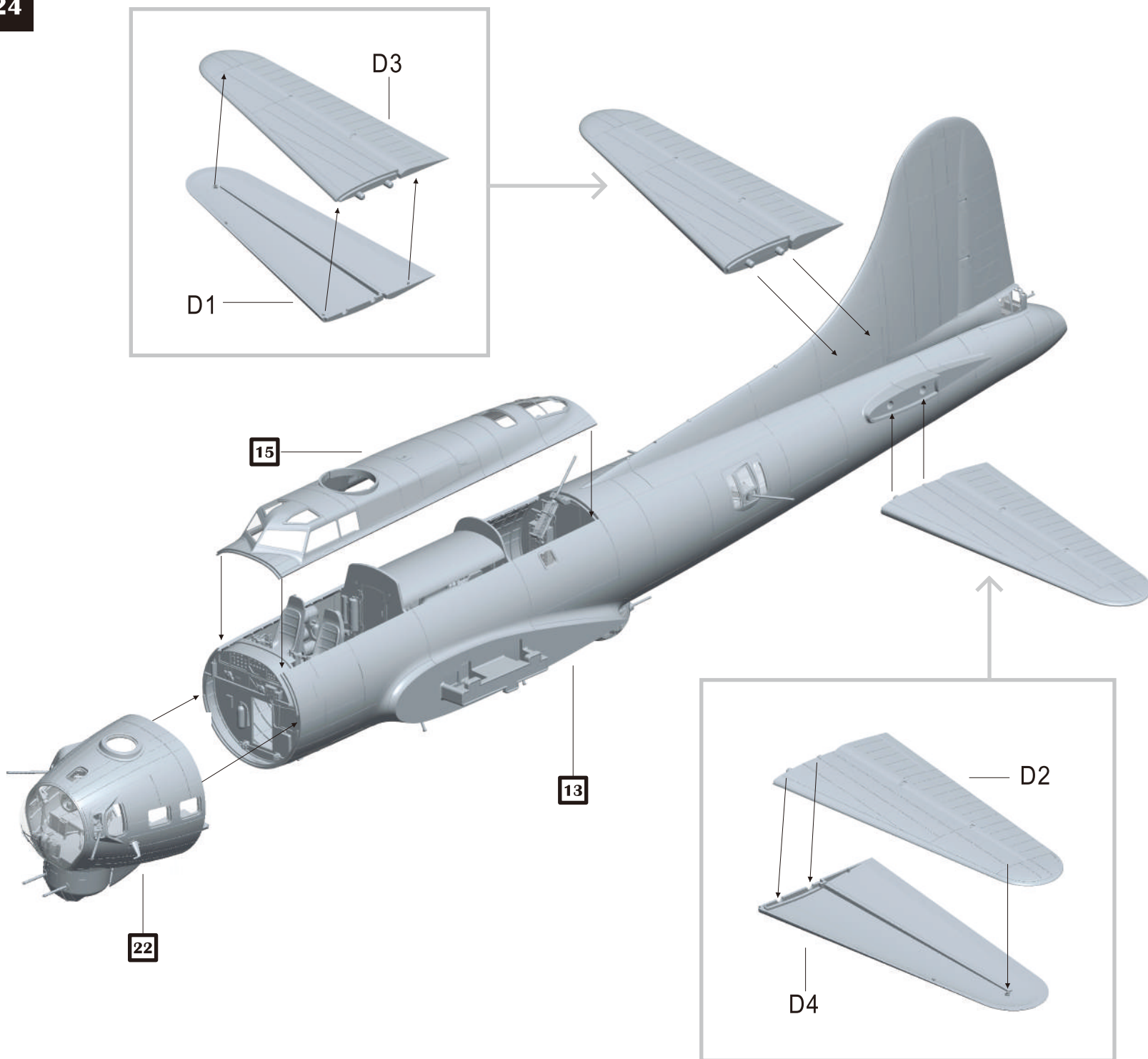
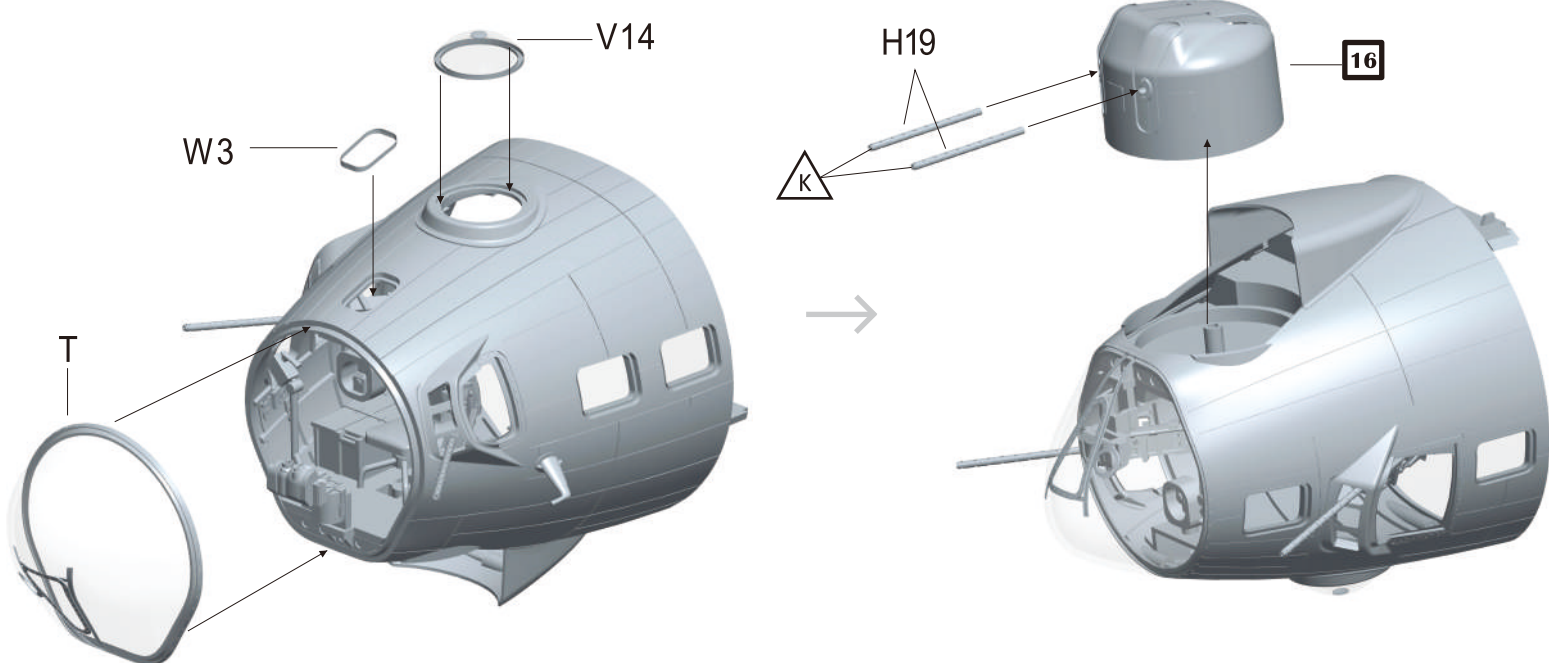

25

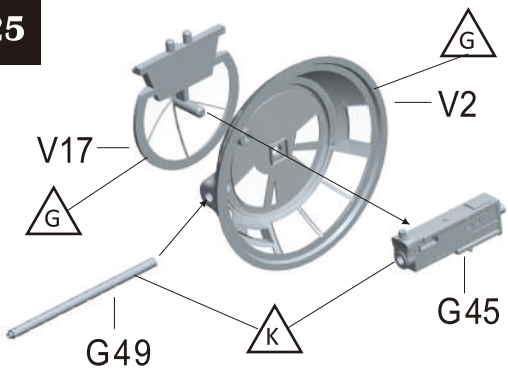

26

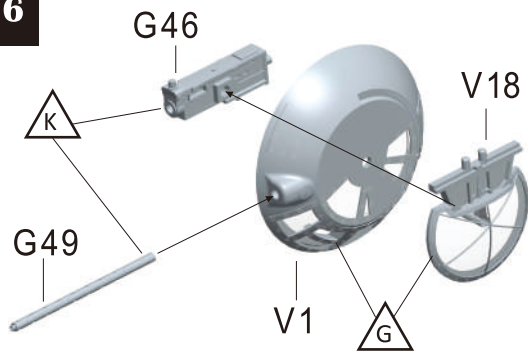

27

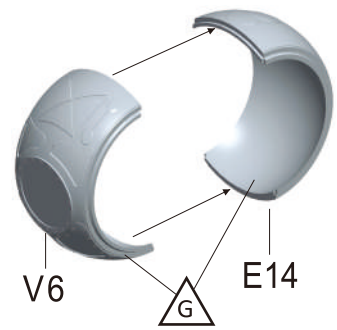

28

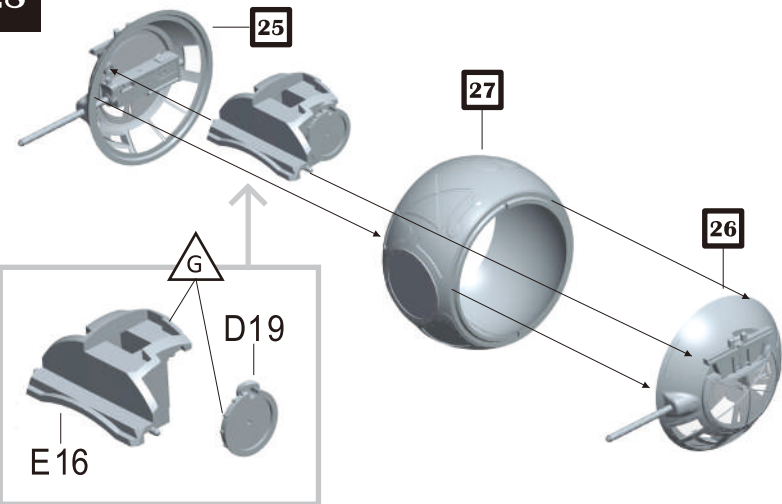

29

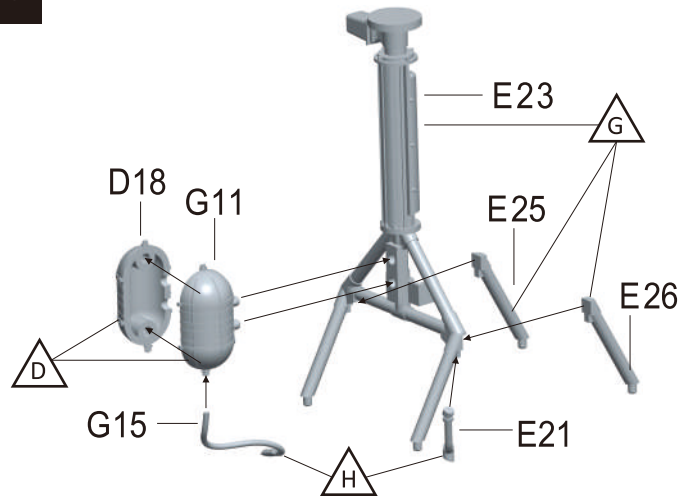

30

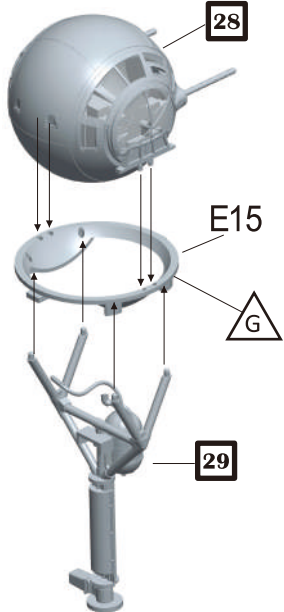

31

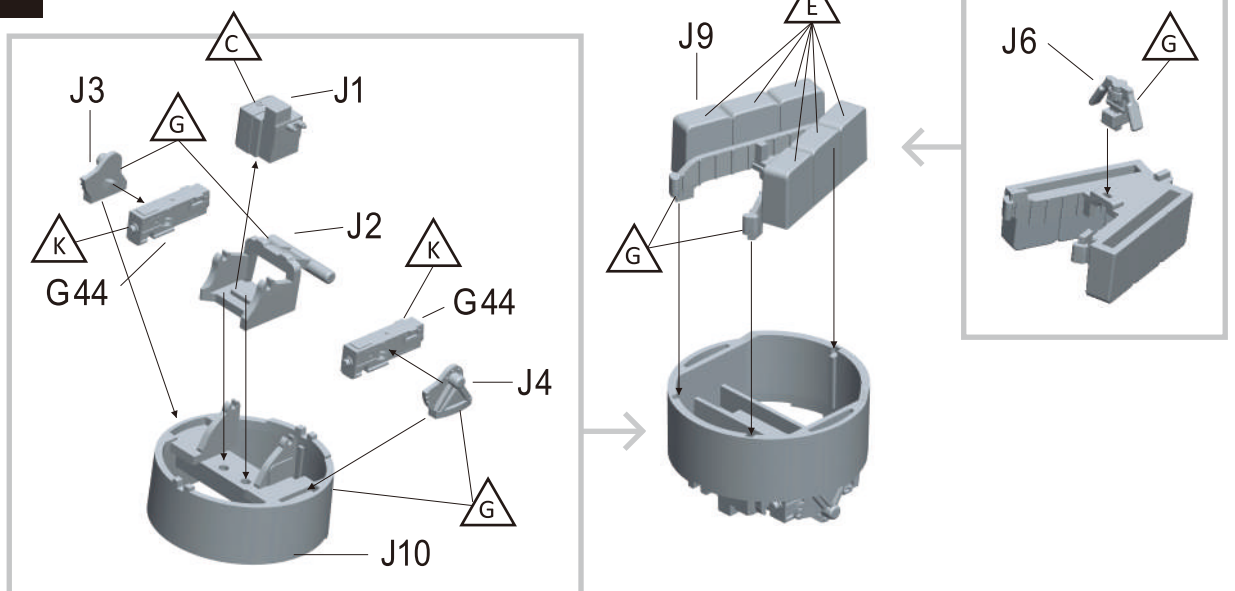

32

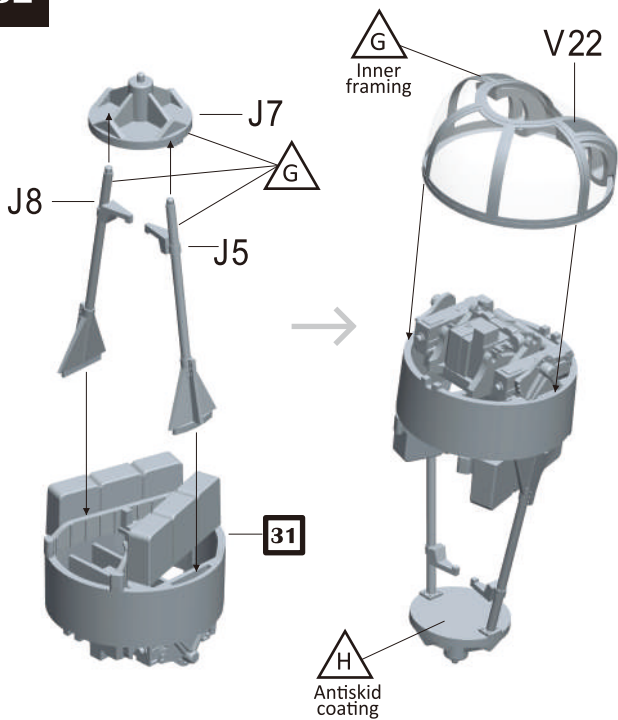

33

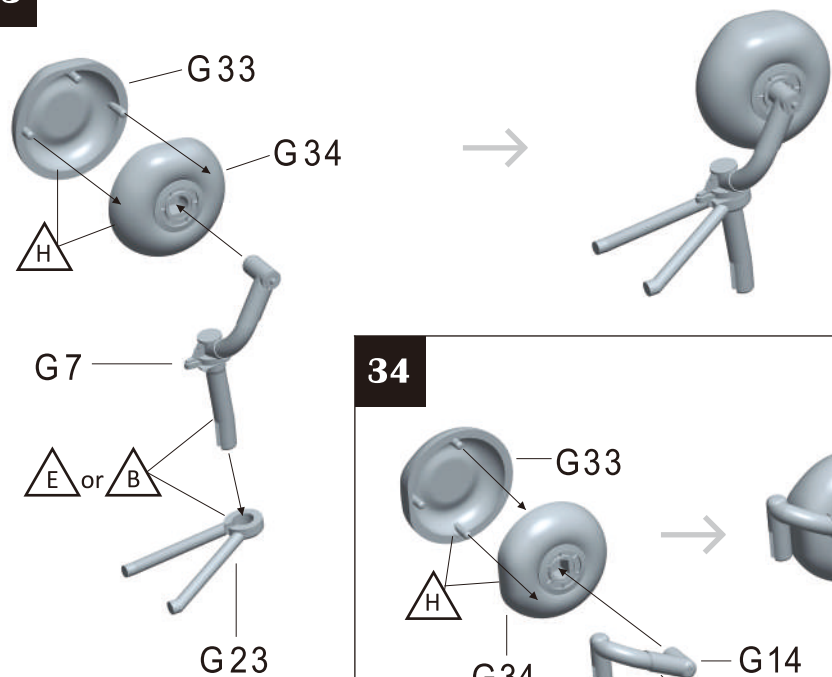

34

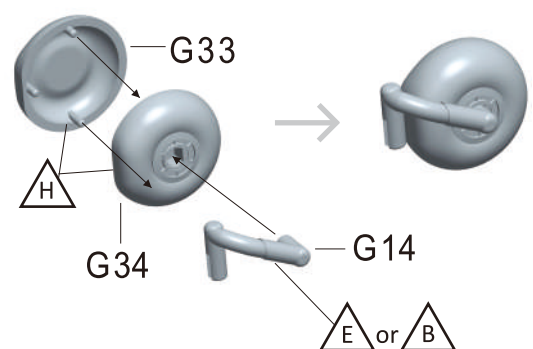

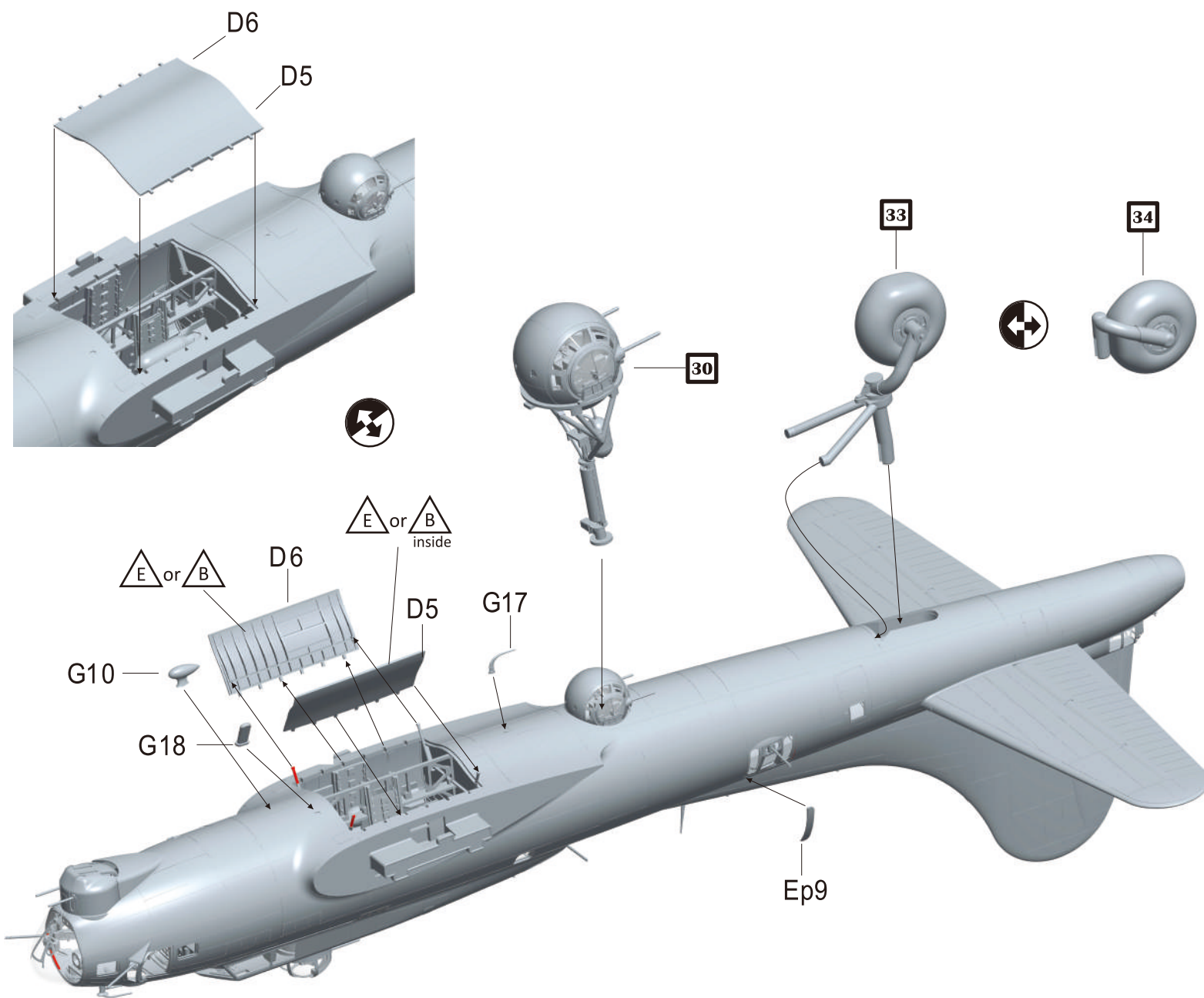
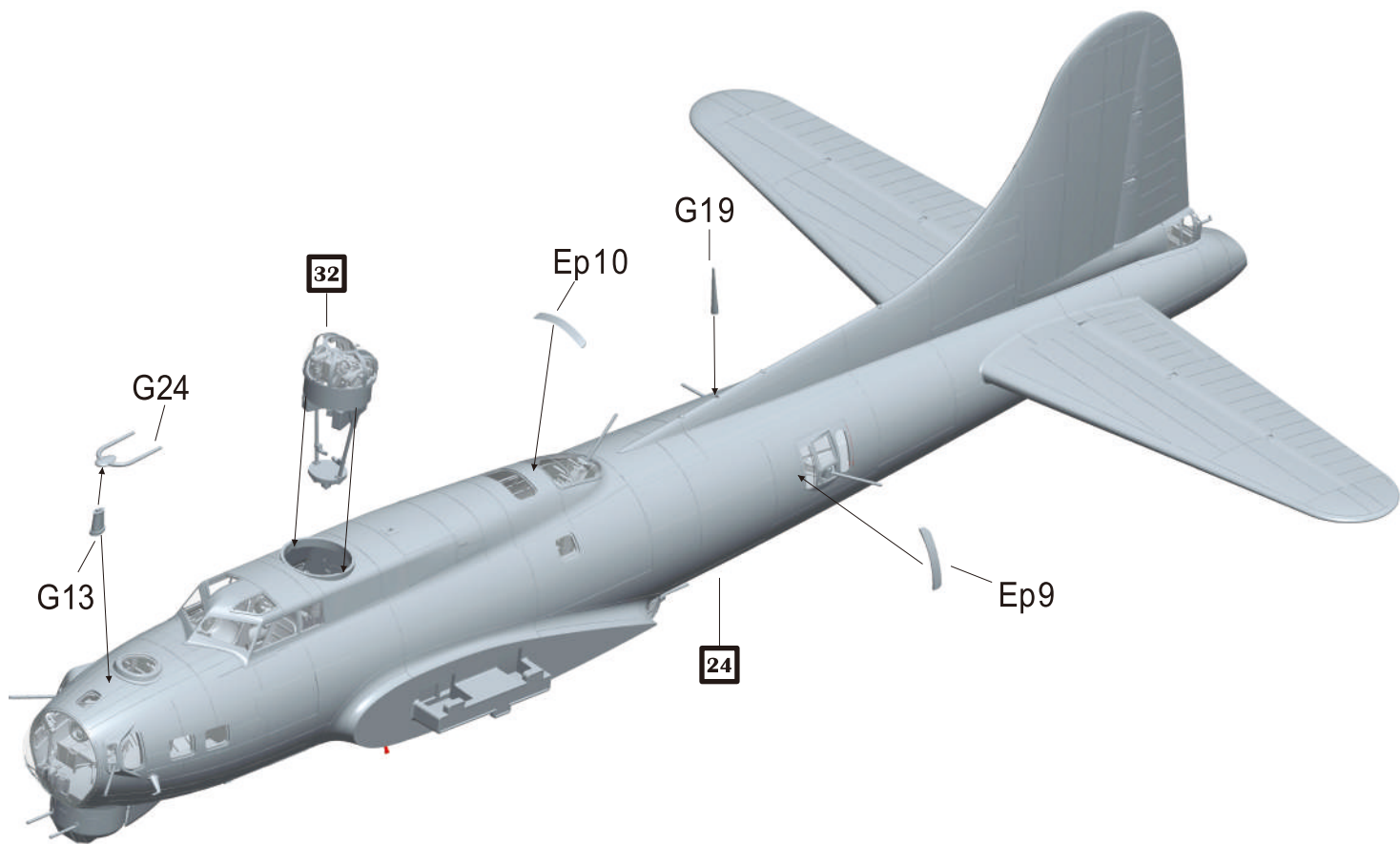

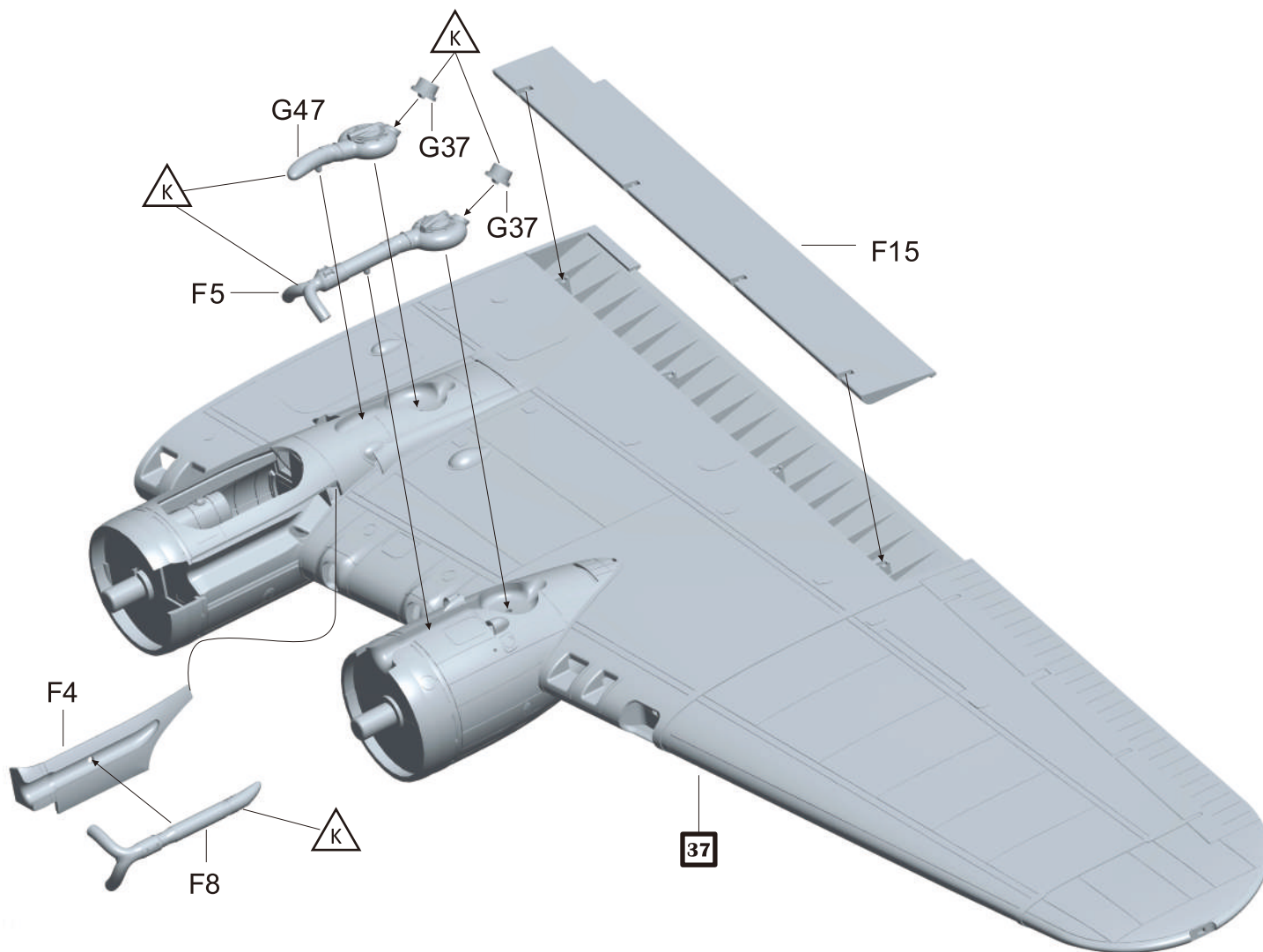
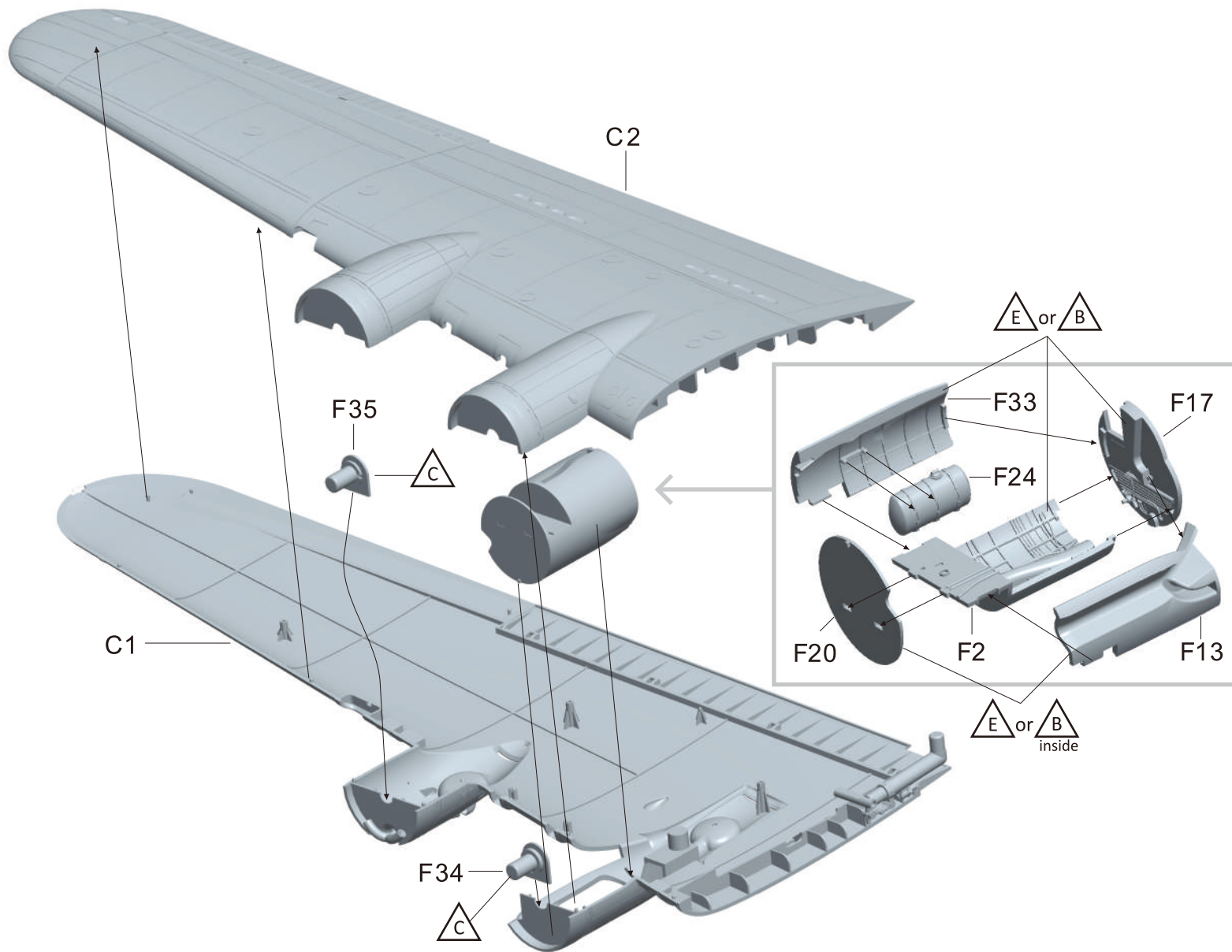

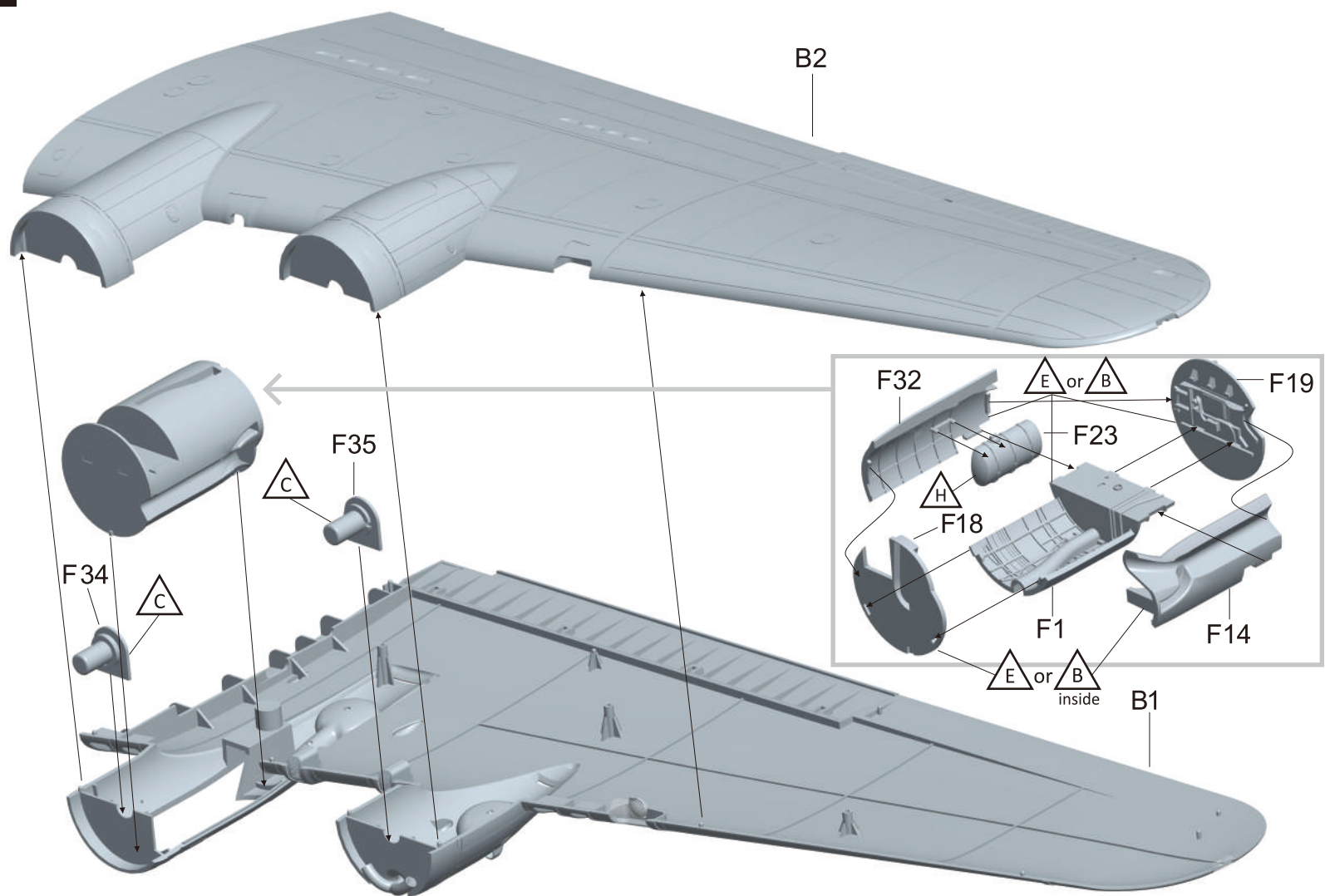
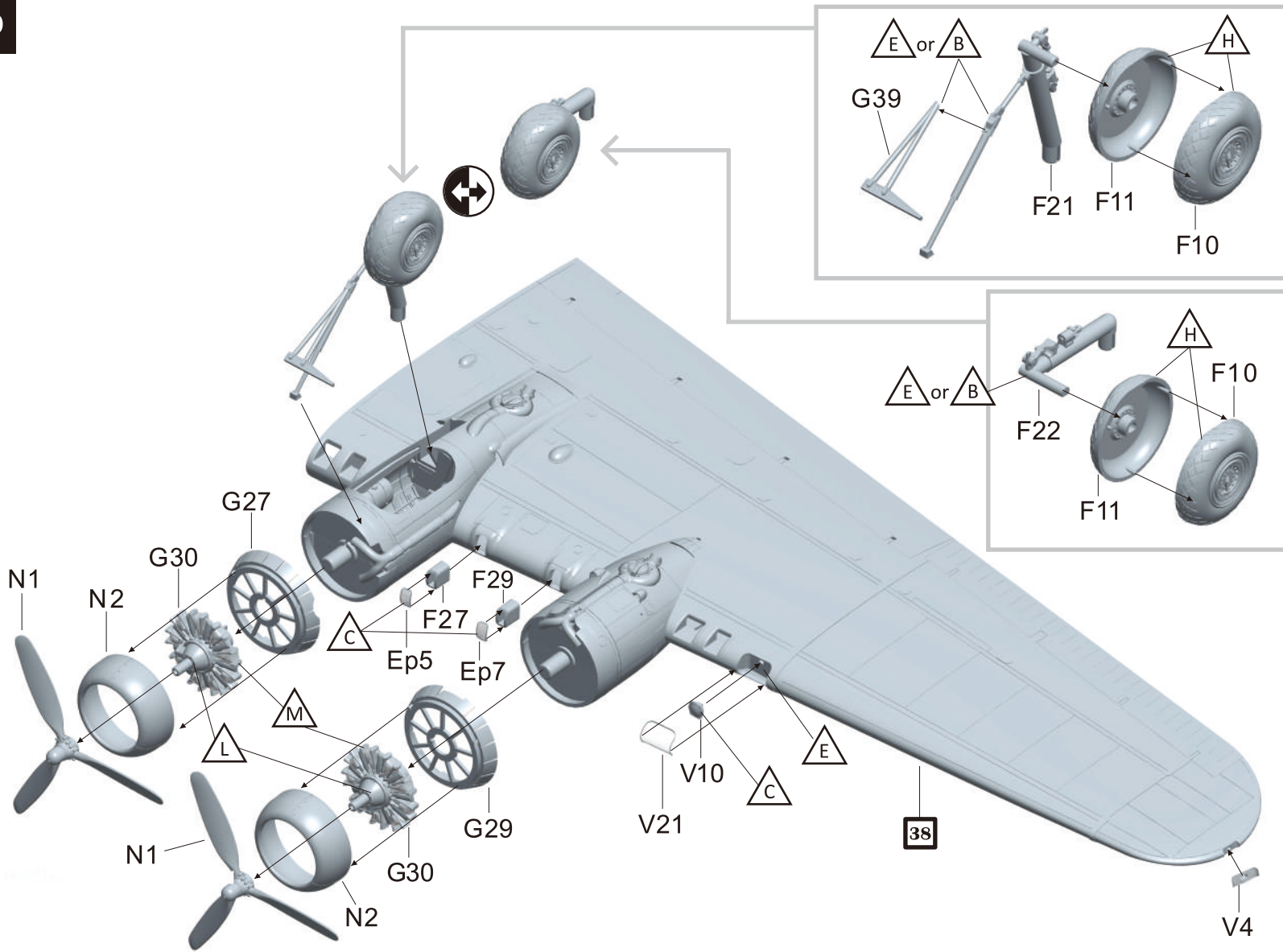

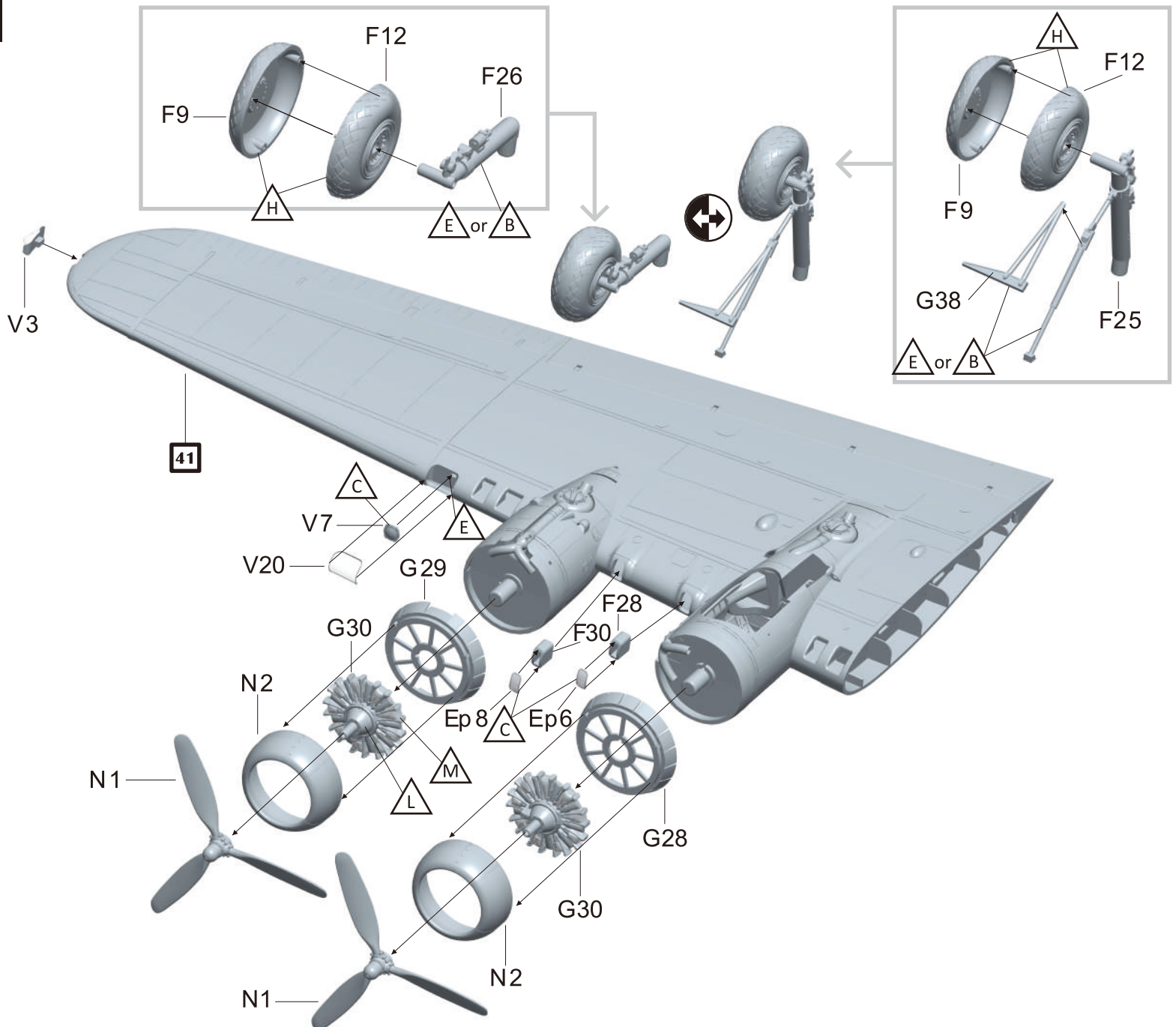
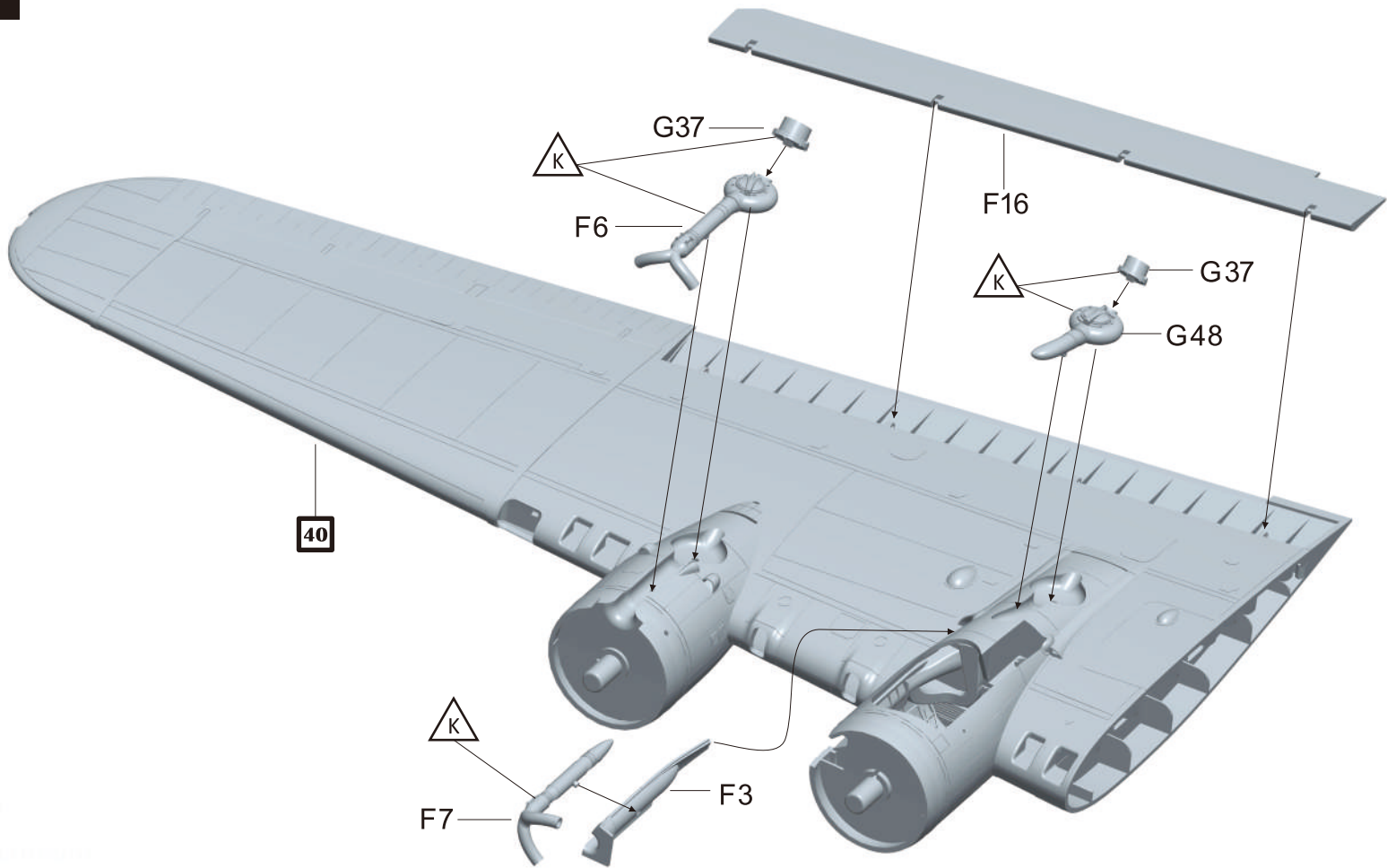

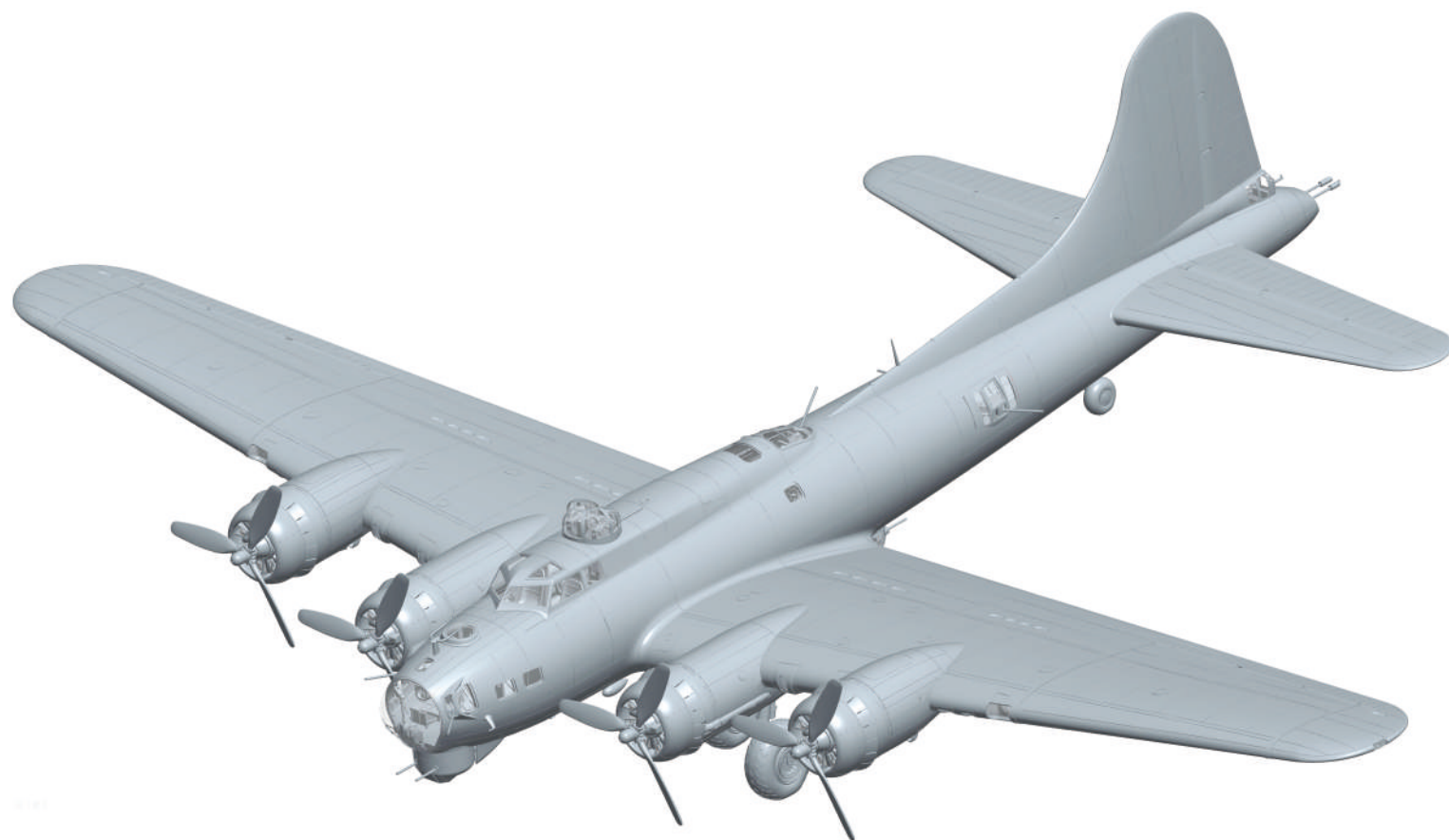
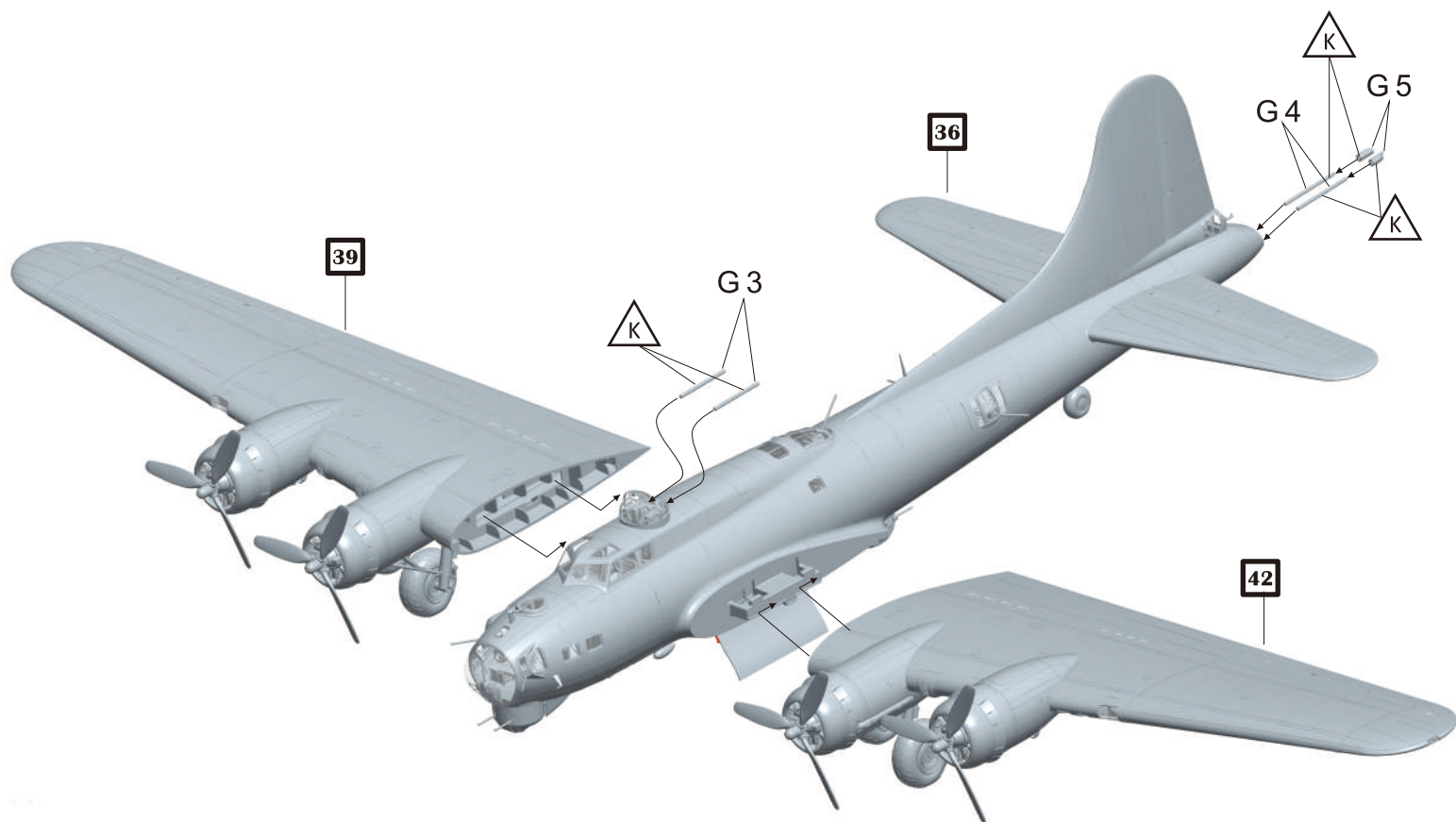

Parts

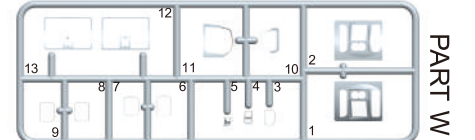
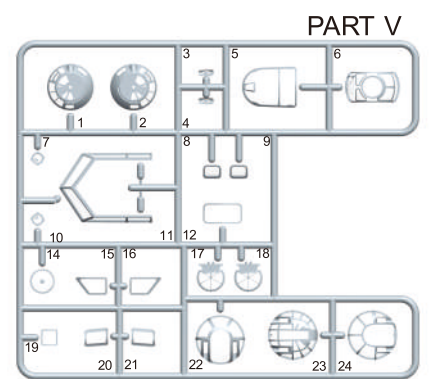
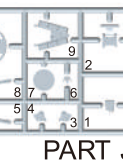
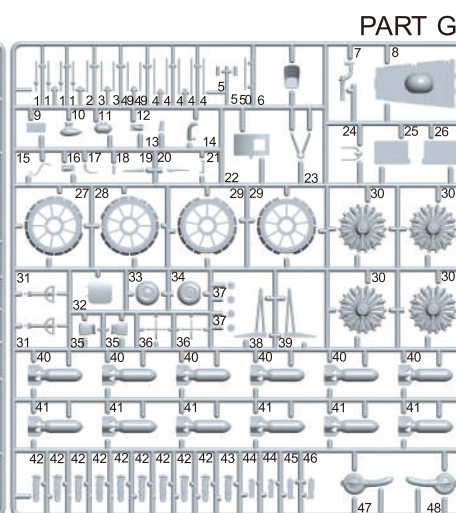
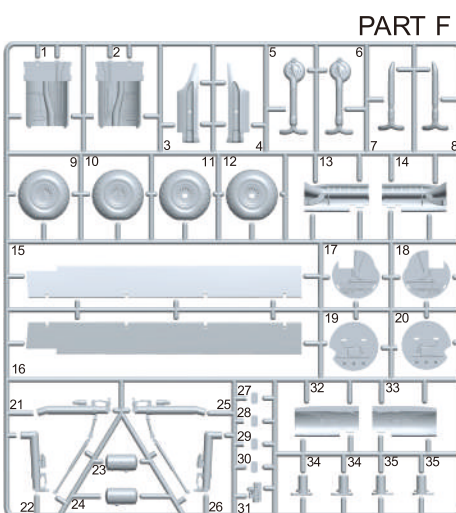
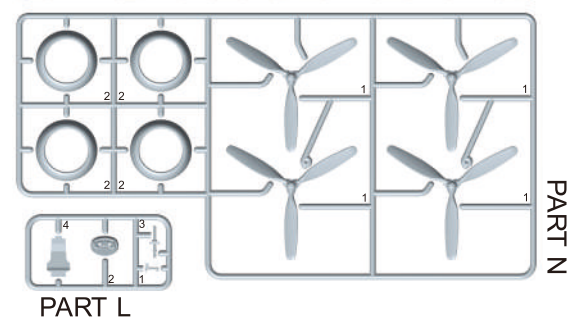
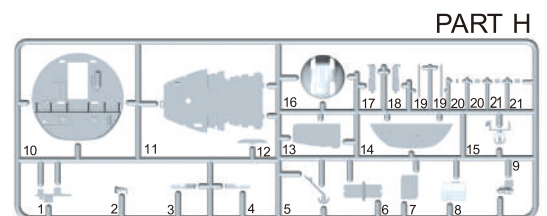
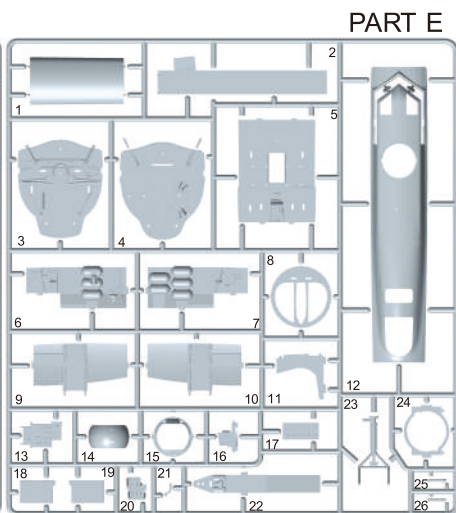
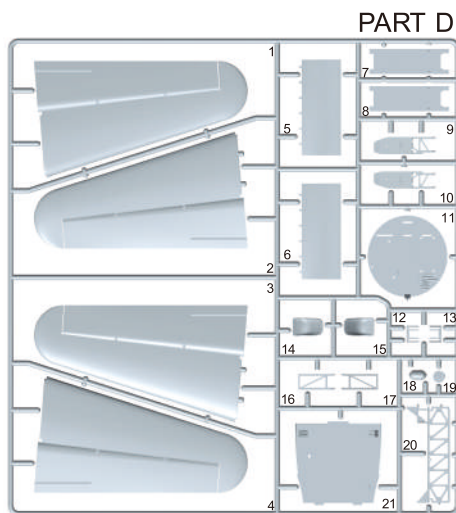
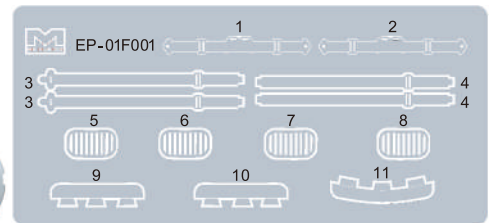
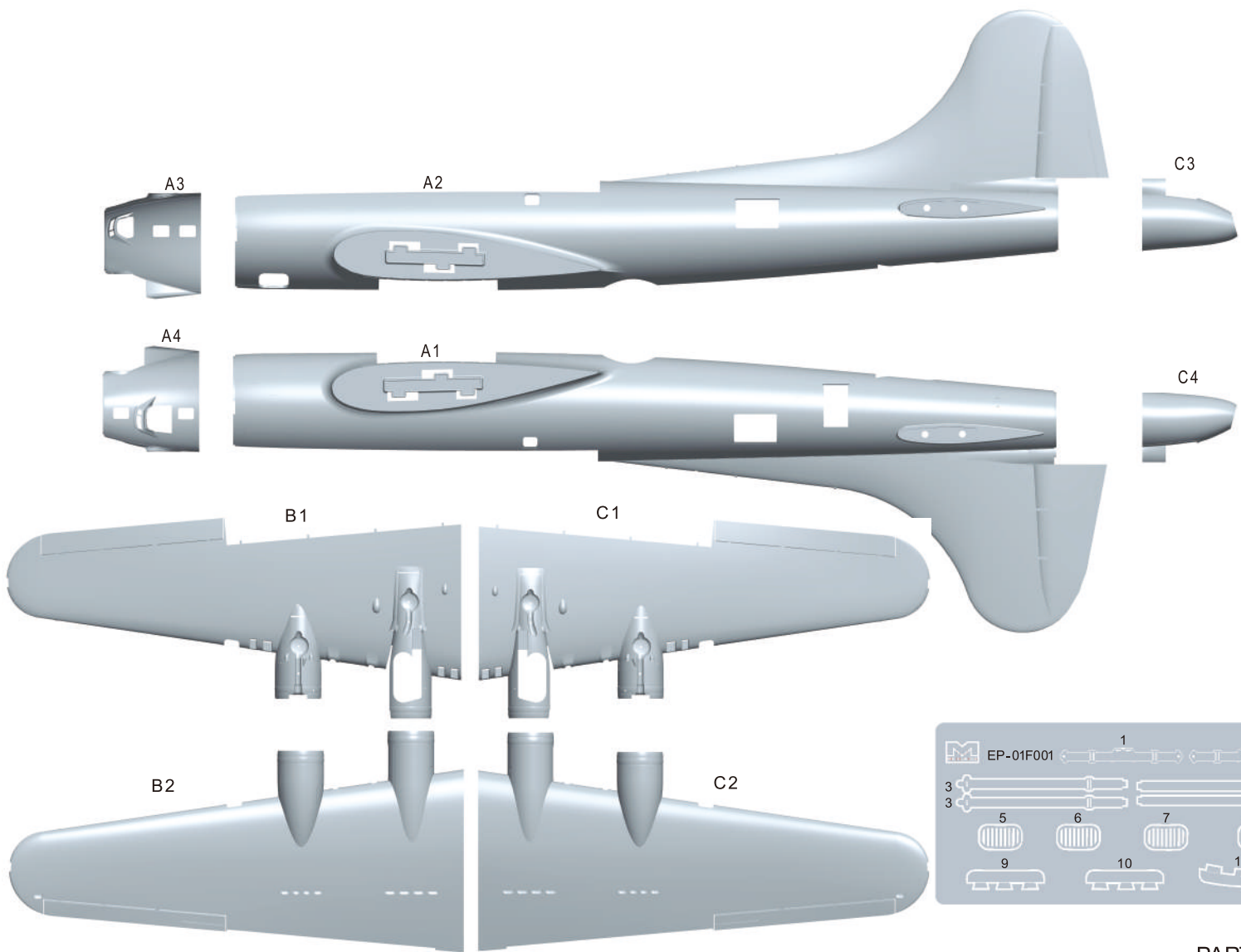

Decals

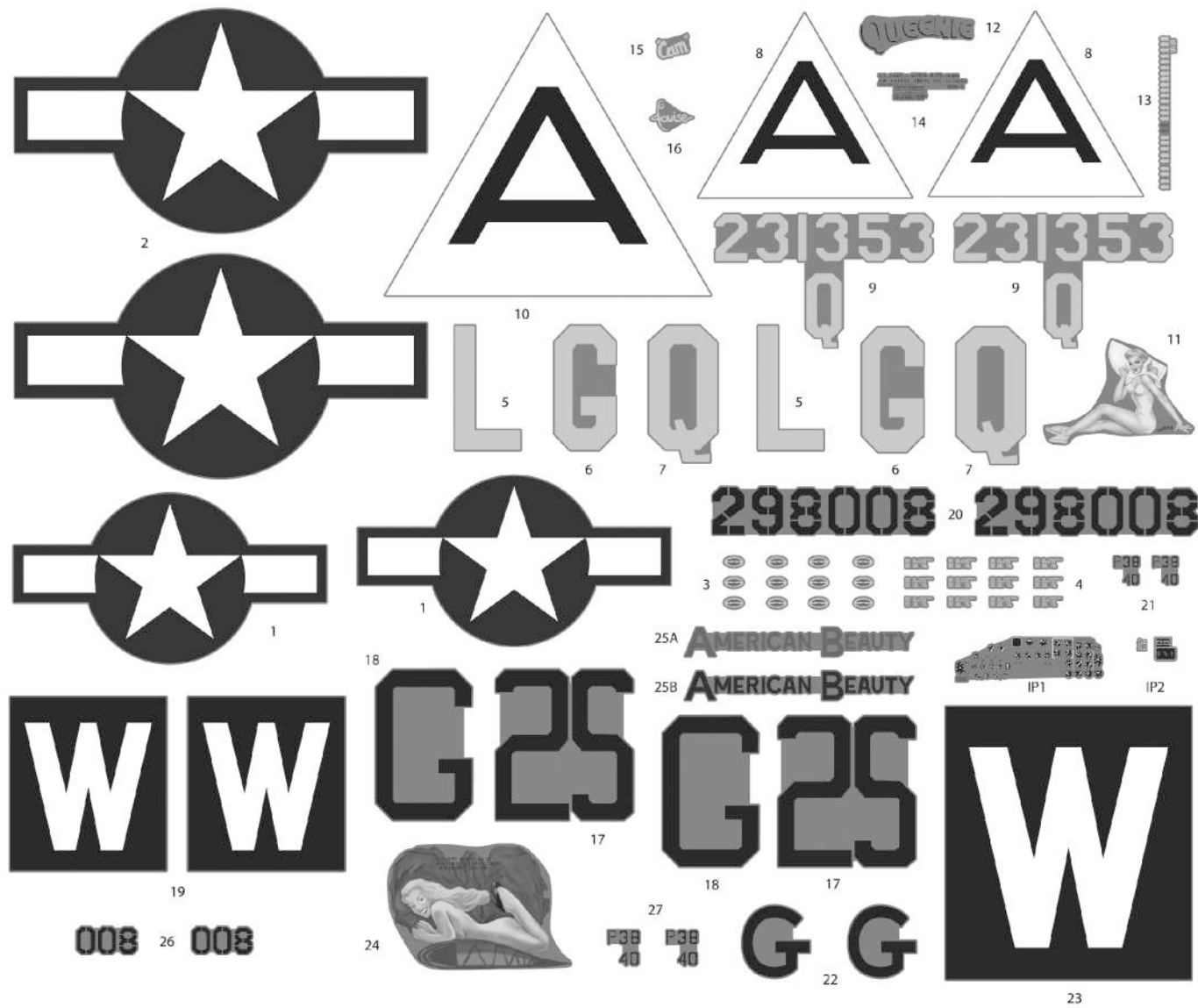

HK Models

B-17G Early Production 01F001 1/48

MARKING

A

B-17G-15-B0, s/n 42-31353, LG-Q, 322nd BS / 91st BG, Bassingbourn, UK, early spring 1944

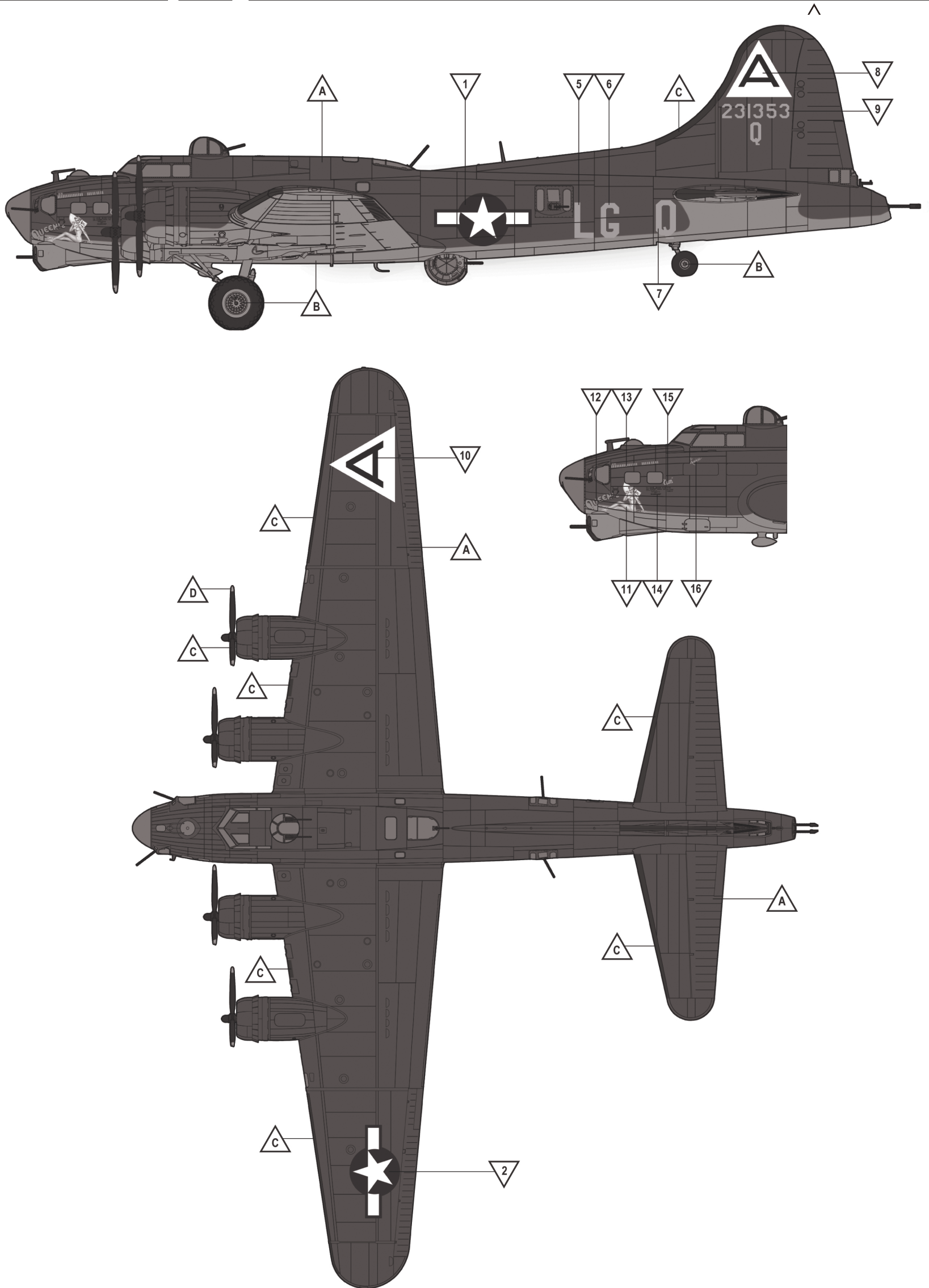

MARKING

A

B-17G-15-B0, s/n 42-31353, LG-Q, 322nd BS / 91st BG, Bassingbourn, UK, early spring 1944

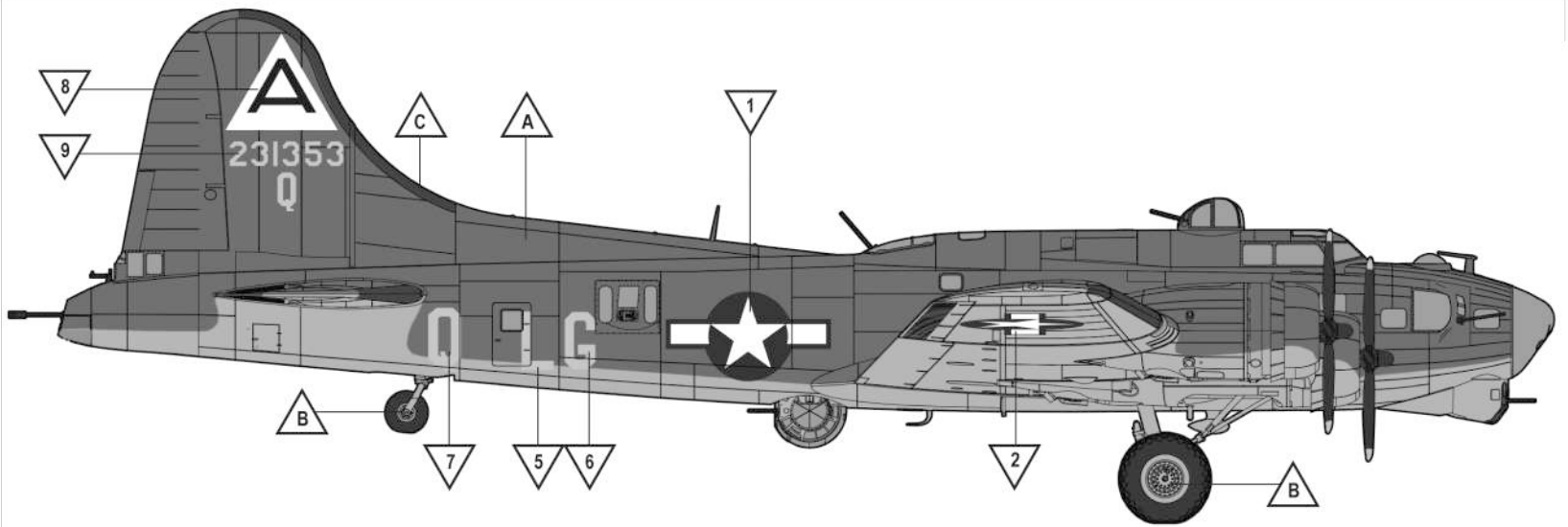

N1

5

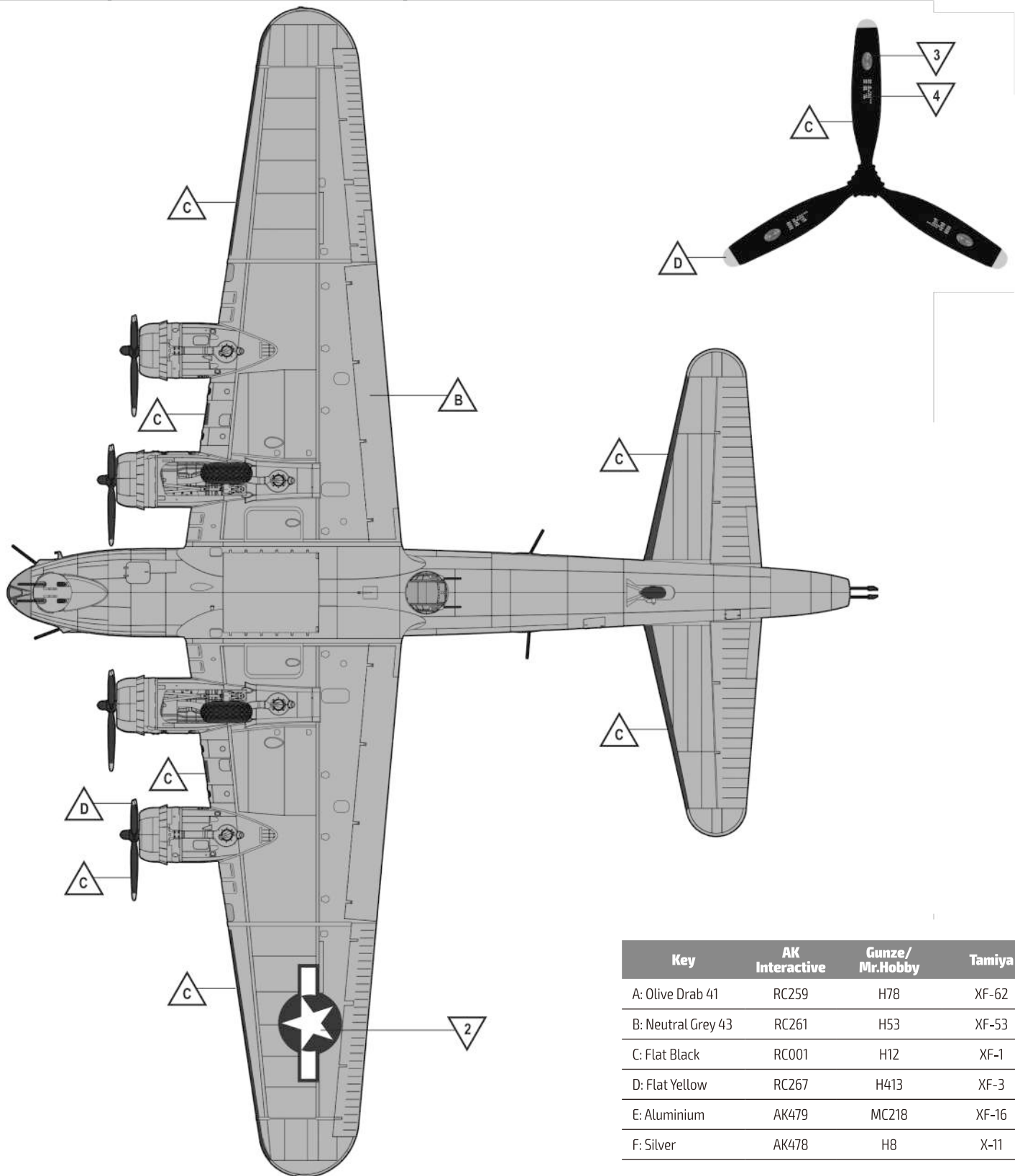

Key	AK Interactive	Gunze/Mr.Hobby	Tamiya
A: Olive Drab 41	RC259	H78	XF-62
B: Neutral Grey 43	RC261	H53	XF-53
C: Flat Black	RC001	H12	XF-1
D: Flat Yellow	RC267	H413	XF-3
E: Aluminium	AK479	MC218	XF-16
F: Silver	AK478	H8	X-11

MARKING

B

B-17G-40-VE, s/n 42-98008, 2S-G, 834th BS / 486th BG, Sudbury, UK, late summer 1944

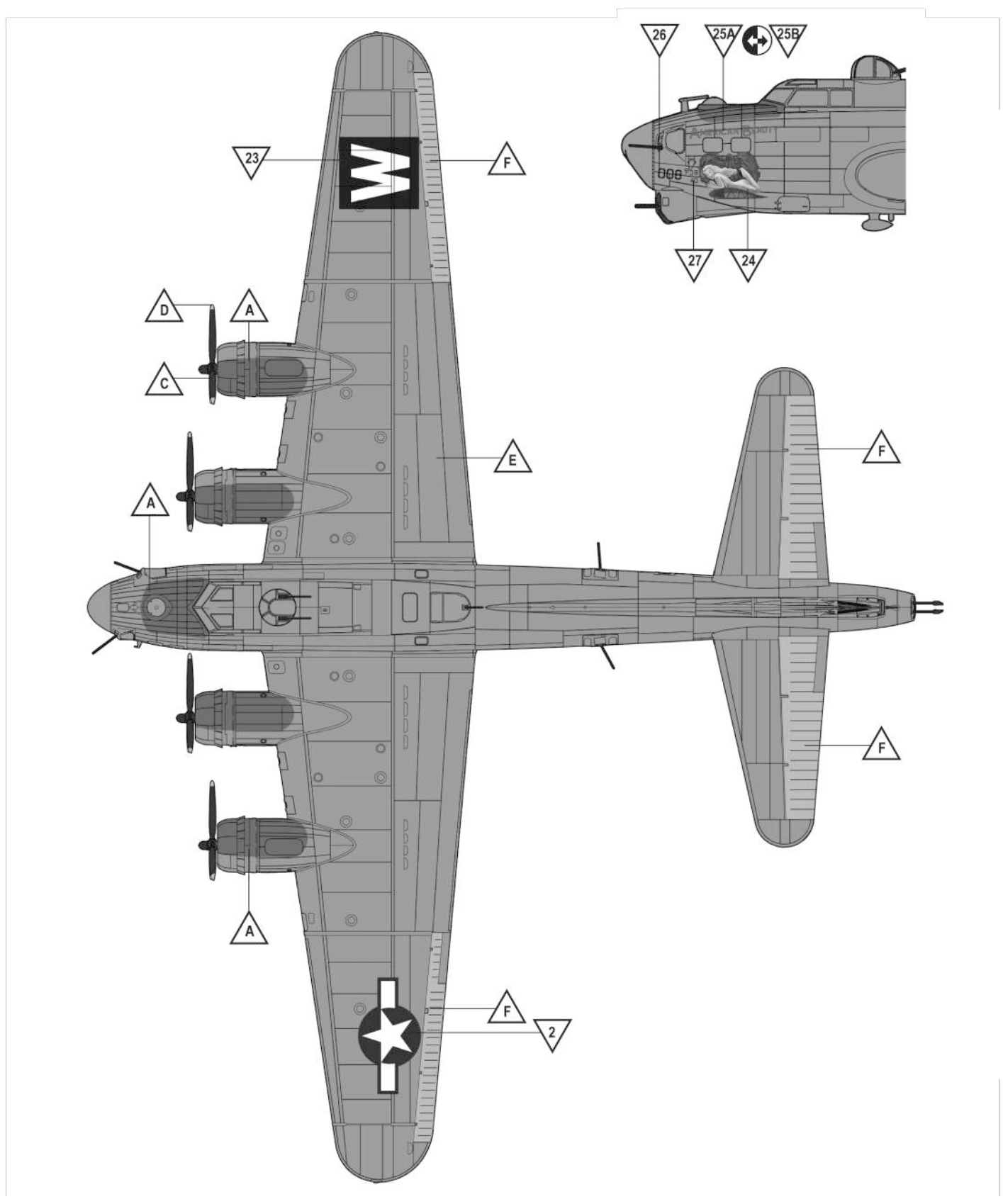
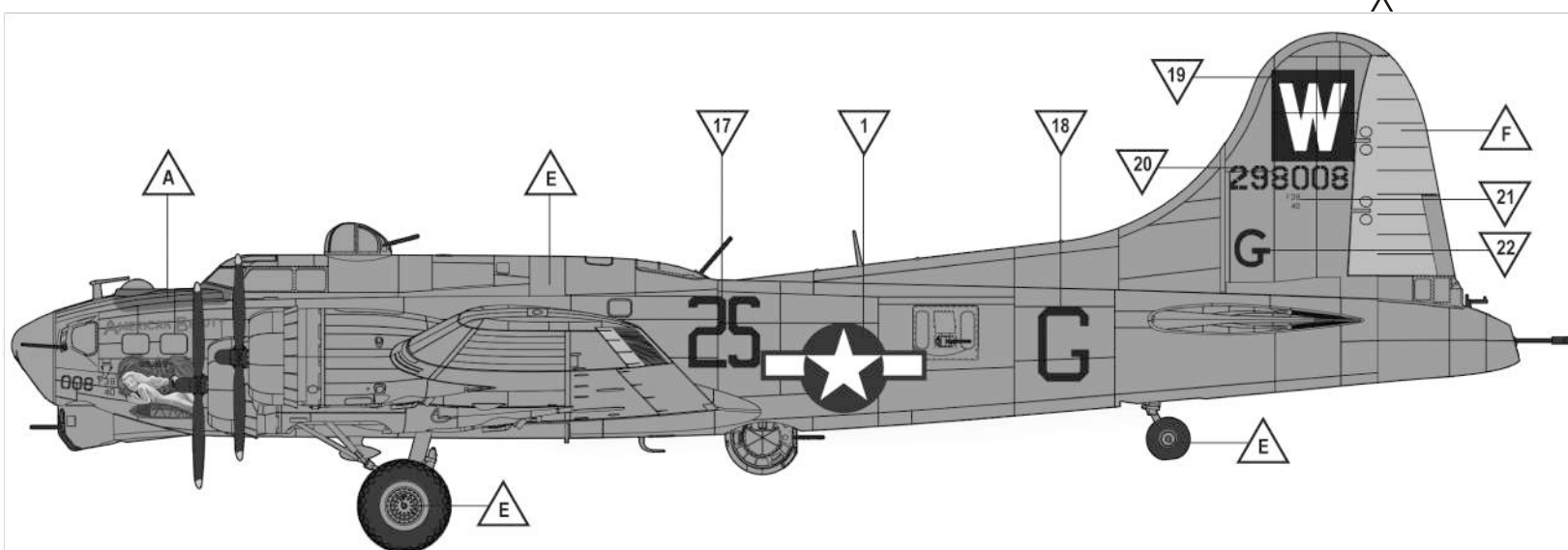

MARKING

B

B-17G-40-VE, s/n 42-98008, 2S-G, 834th BS /486th BG, Sudbury, UK, late summer 1944

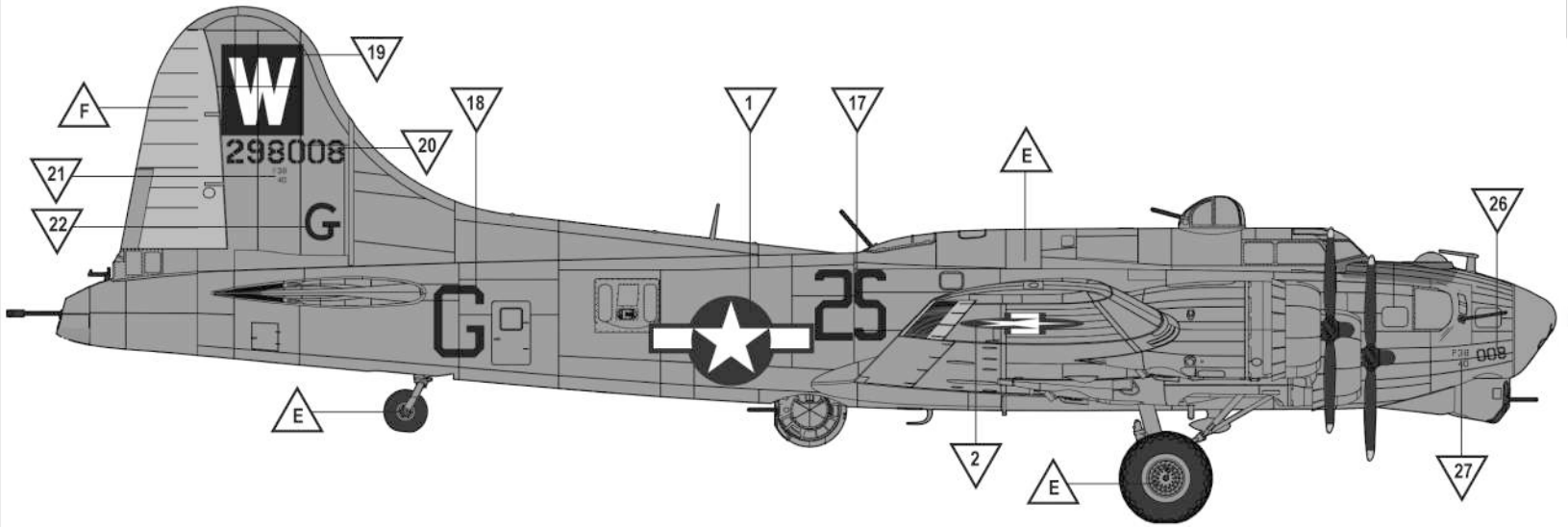

N1

5

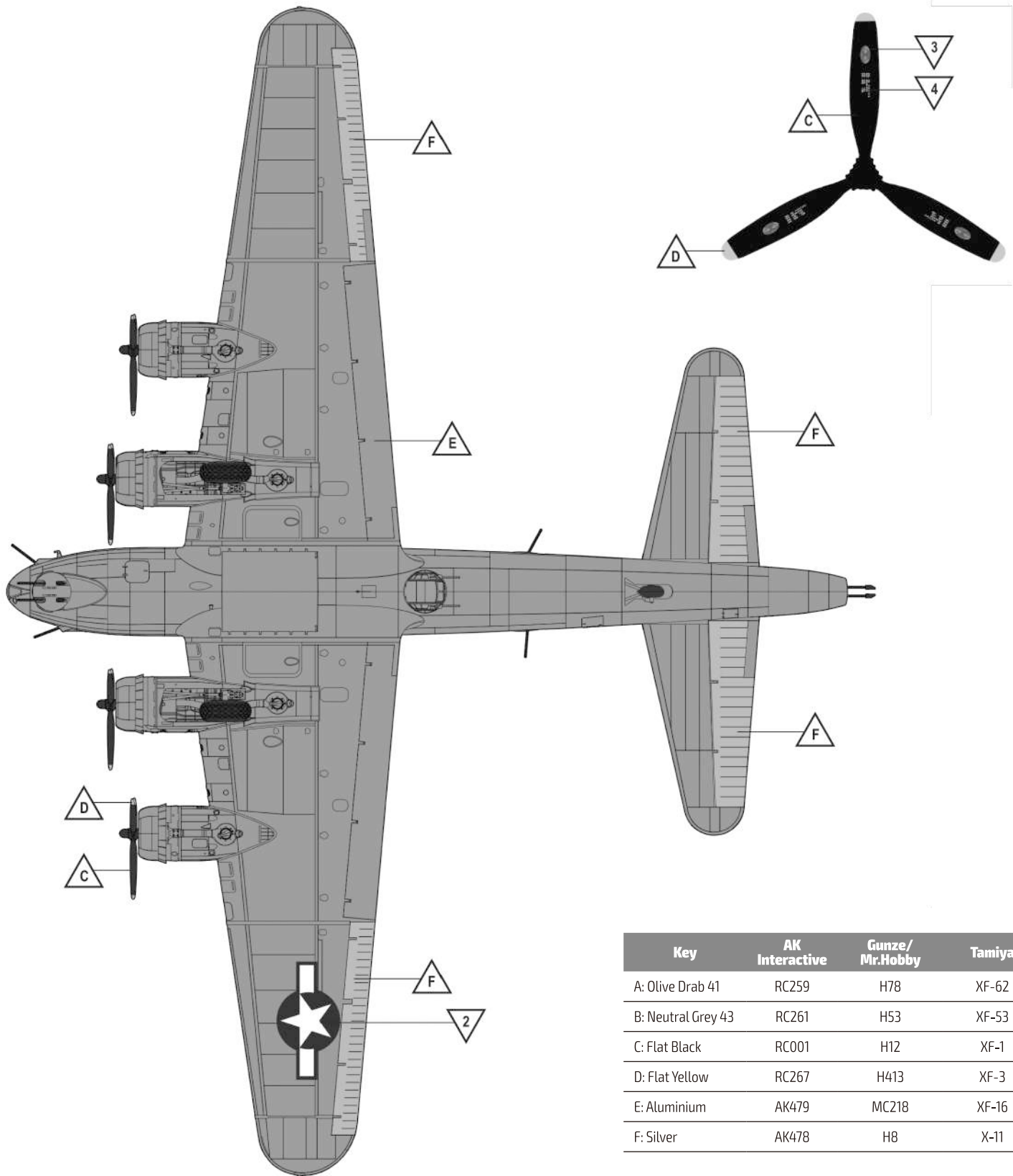

Key	AK Interactive	Gunze/Mr.Hobby	Tamiya
A: Olive Drab 41	RC259	H78	XF-62
B: Neutral Grey 43	RC261	H53	XF-53
C: Flat Black	RC001	H12	XF-1
D: Flat Yellow	RC267	H413	XF-3
E: Aluminium	AK479	MC218	XF-16
F: Silver	AK478	H8	X-11

Colour Guide

Decals

Key	AK Interactive	Tamiya	Gunze/Mr.Hobby
A: Olive Drab 41	RC259	XF-62	
B: Neutral Grey 43	RC261	XF-53	H53
C: Flat Black	RC001	XF-1	H12
D: Flat Yellow	RC267	XF-3H413	C364
E: Aluminium	AK479	XF-16	MC218
F: Silver	RC230	XF-26	H8
G: Dull Dark Green	RC230	XF-26	H302
H: Rubber Black	RC022	XF-85	H77
I: Light Wood	AK779	XF-78	79
J: Brass	AK475 / AK4002	X-12	MC219
K: Gunmetal	AK483 / AK798	XF-10	MC214
L: Grey	RC296	XF-77	H331
M: Steel	AK476	XF-56	H18
N: Clear Green	RC505	X-25	H94
O: Clear Red	RC503	X-27	H90

In cooperation with:



www.ak-interactive.com



Large
Scale
Modeller

www.largescalemodeller.com

General kit help/reference: **Large Scale Modeller**
 Illustration, manual layout and format: **HK Models & AK-Interactive**
 Manual and assistance: **AK-Interactive**
 Introductory text: **Cees Broere**