

REHEAT MODELS RH063 MIRAGE 2000 1/72 DETAIL SET

Reheat Models thanks you for purchasing this product which has been designed for the neat little Italeri 1/72 Mirage 2000 kits, though with modification it could be used on the Airfix/Heller models. Enough cockpit parts are supplied for two single seat Mirage 2000C aircraft, or you may like to use the extras to model the two seat D-N version. Resin parts are supplied for the missing air bleed ducts situated on the wing/fuselage join.

• WORKING WITH BRASS •

We suggest that you carefully study the written instructions and illustrations. Familiarise yourself with the etched parts before starting. Remove the etched parts with a sharp (preferably new) knife blade and cut on a firm surface - a small piece of glass covered with a sheet of paper is ideal. Cut the tab close to etched item and clean up any remaining scar by holding the part in a pair of flat nosed pliers and using a fine file. For some of the smaller, more fiddly parts, spares are provided on the fret.

• STAGE 1 •

Carefully remove the moulded detail on the Italeri cockpit tub (Part 4A) and fix into place the etched consoles. The two part throttle can be assembled and fixed onto the left hand console. The etched rudder pedals can be fixed directly onto the moulded plastic wedges. The etched instrument panel fits as per Italeri instructions.

If you decide to model the two seat Mirage 2000D/N then some modification of the instrument panels will be needed in order to fit the cockpit tub.

Reheat Models RH08 AIRCRAFT INSTRUMENTS (available from the manufacturer) are recommended to further enhance the instrument panels. The bezel glass can be simulated with Krystal Kleer or thin acetate.

• STAGE 2 •

The etched harness straps can be fixed onto the kits seat or combined with Aeroclub's Martin Baker Mk.10 (EJ011). Some adjustment may needed to get aftermarket ejector seats to fit the Italeri kit.

• STAGE 3 •

The Head Up Display (H.U.D.) should be carefully folded before fixing into position. Take care not to damage the upright frames. The 'glass' can be simulated with thin acetate. The Italeri coaming (part 13A) will need to have its base reduced as it sits too high in the cockpit.

Canopy sills, handles and a mirror are provided on the fret. The raised square end of the canopy sill faces forward, the elongated part toward the rear. It may be better to pre-paint these and then fix to the canopy with PVA adhesive to avoid damage to the clear parts. Cockpit sills are also provided, the square end facing forward - if modelling a two seat Mirage, some adjustments may be needed to the sills.

Replacement IFF, UHF, fin mounted VOR and altimeter aeriels are provided as well as nose pitot's and temperature probes. All these are best left off until the model has been painted and decalced. Locating tabs are included on the etched item, simply drill a hole into the kit surface and fix the new part into place. Spare parts are included. The etched fuselage strakes can be fixed into place as per Italeri instructions.

Two resin casting are provided for the missing air spill ducts that are situated along the wing/fuselage join. These need to be carefully removed from their 'plinths' with a fine razor saw before fixing to the kit. The 'open' end faces toward the rear of the aircraft. Fill any gaps with PVA or moistened Milliput.

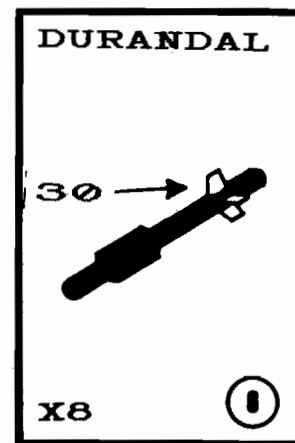
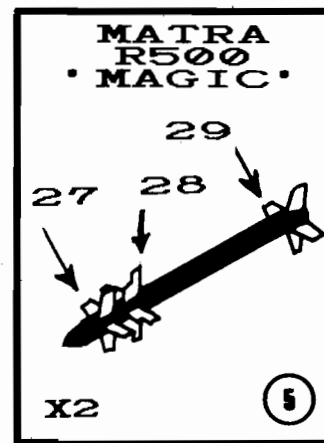
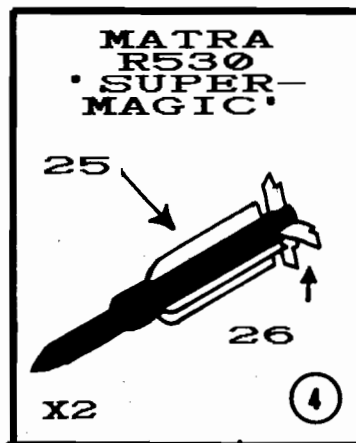
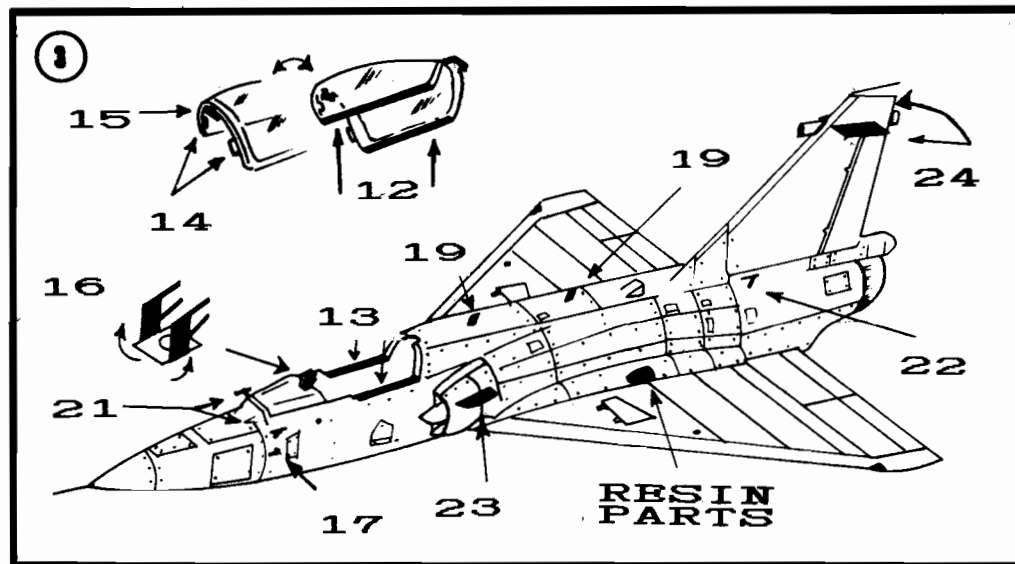
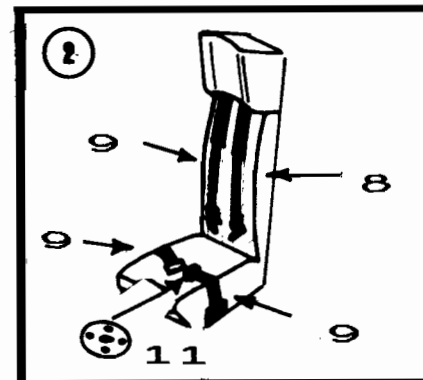
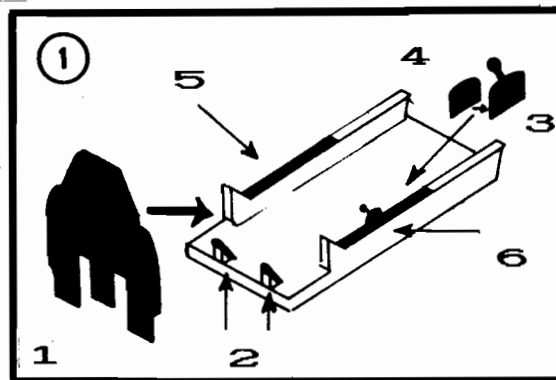

• STAGES 4, 5 & 6 •

Replacement fins are supplied for the Matra R500 'Magic' and Matra R530 missiles as well as the Durandal bombs. The etched parts have locating tabs to help them fix onto the kit part. Carefully remove the moulded fins and fill in all the holes and slots (preferably with superglue + accelerator) on the Italeri kit parts and smooth down. Using a small drill, make new holes to accept the etched fins. Fix in place with superglue - take your time. Some spare fins are provided.

• STAGE 7 •

Parts are supplied for the nose and main undercarriage doors as well as oleo scissors. The front undercarriage has three doors - one attached to the leg and two hanging from the fuselage. The leg door replaces Italeri part 26A and simply fixes onto the undercarriage, making sure the half-etched detail faces inwards.

The hanging doors are best added after the fuselage join has been made perfect. Remove the moulded kit items and carefully fix in the etched parts, making sure the half etched detail faces inwards. Hinge tabs are included on the etchings to aid placement. The main undercarriage doors replace parts 33A & 34A and simply fix into place, making sure the half-etched detail faces inwards.

Gulf modified Mirage 2000C's carried chaff dispensers on the rear underside of the fuselage and these are provided in this set. Italeri kit part 35A needs about 5mm trimming from the end before fixing into place. The central dispenser can be made by supergluing the required etching to a piece of plastic card/strip and cutting to shape. The other dispenser etchings can be glued into place following our diagram. Strictly speaking these are flush to the surface of the fuselage, but we have etched our items as thinly as possible.

STAGE 8

Oleo scissors simply replace those moulded on the kits undercarriage. Remove the kit parts and carefully fold the etched links before fixing into place. The nose gear door fits into place as per Italeri instructions, the half etched detail facing inwards.

• STAGE 9 •

This set provides an etching for the inner exhaust petals and parts for the external petal detail on the exhaust nozzle. Take the inner petal etching and fix one end of the ring to the inside of the kit nozzle (part 10A), making sure the petals line up with the external detail. Then carefully fix the ring into place section by section until the two ends meet up. The petals can now be fixed down.

The 16 individual outer petals can be fixed straight on top of the moulded parts, again making sure they line up with the inner petals.

• FURTHER SUGGESTIONS •

After adding all that brass to your Mirage you would'nt want to spoil the finish. The decals in the Italeri kits are of good quality, but for real excellence there are some attractive Mirage schemes from MODEL ART DECAL SYSTEM of P.O. Box 64, Bury, Lancashire BL9 0SF. A Mirage 2000 ladder is also available from PP Aeroparts.

• SOURCES •

Replic No.16 Dec 1992 - Editions D.T.U., 114 rue Matre, 92110 Clichy, France.
Airforces International July 1988 - Model Aid Publications, Malta.
Air Forces Monthly June 1988 - Key Publishing, UK.

Reheat Models 1A Oak Drive, North Bradley, Trowbridge, Wilts BA14 0SW England

© 1993 REHEAT MODELS

MADE IN ENGLAND

