

These decals are designed for the AMT/Ertl KC-135A kit. Correctly sized 55" replacements for the kit supplied "USAF" wing titles are provided. All aircraft carried standard markings as supplied in the kit, including yellow door and hatch outlines. Note the differing locations of the "U.S. Air Force" titles on the fuselages.

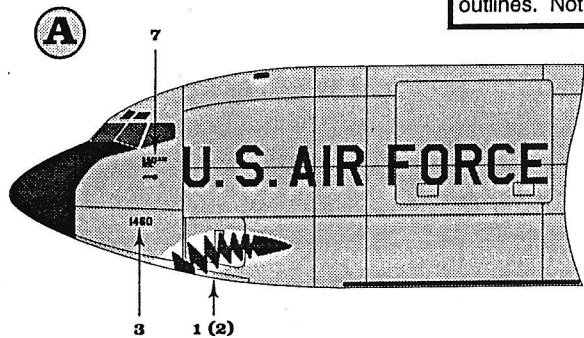

KC-135A, 57-1460, 11 ARS, Altus AFB, Oklahoma. Seen while TDY to Korat AB, Thailand with the 4104 ARS in December 1972. Overall Coroguard (dull aluminum paint) finish with F.S. 16473 engine center cowlings. Tip of vertical fin black.

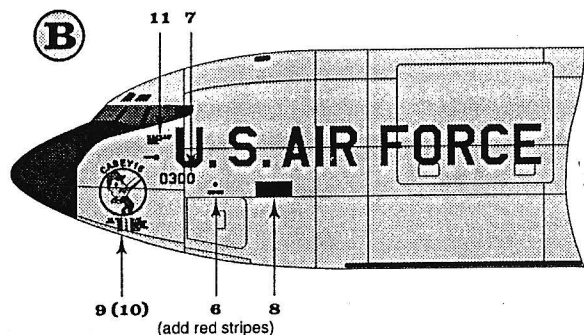
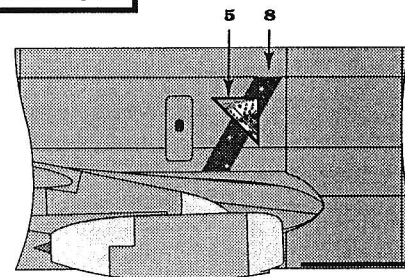

KC-135A, 61-0300, 22 ARW, March AFB, CA, 1988. 15th Air Force Commander's aircraft. Overall F.S. 16473 with white engine center cowlings and pylons. Note white outlined black mask around cockpit. Use black pieces provided aft of cockpit windows, then apply white stripes as shown. Use wide SAC Milky Way bands. Vertical fin tip black.

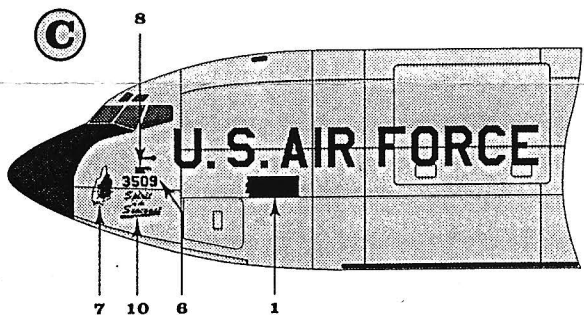
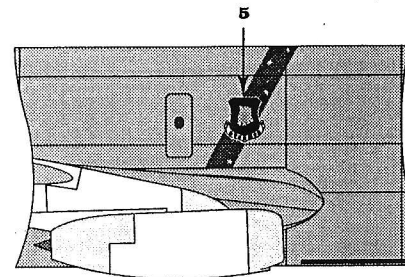

KC-135A, 62-3509, "Spirit of the Seacoast", 509 BMW, Pease AFB, NH, 1988. Overall F.S. 16473 with black vertical fin tip. Use narrow SAC Milky Way bands.

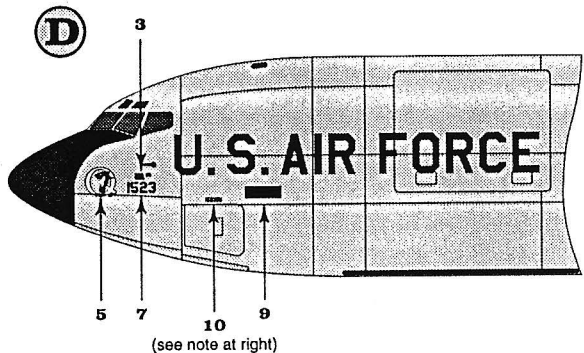
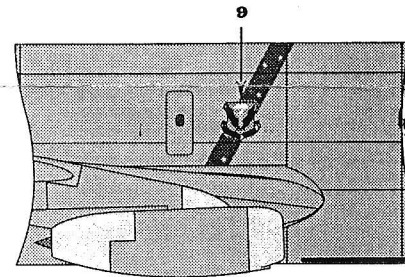

KC-135Q, 59-1523, 9 SRW, Beale AFB, CA, 1990. Overall F.S. 16473 with black vertical fin tip. Use wide SAC Milky Way bands.

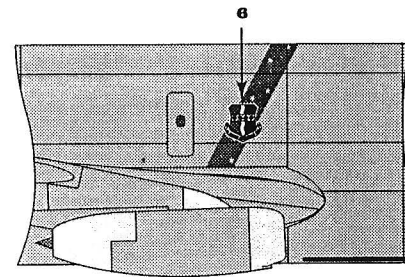

- Decal No. 10:**
- ← 3. Apply yellow devices
  - ← 1. Apply blue & white base
  - || ← 2. Apply red stripes

Standard SAC shield placement on left side of aircraft A through D (aircraft A shown).

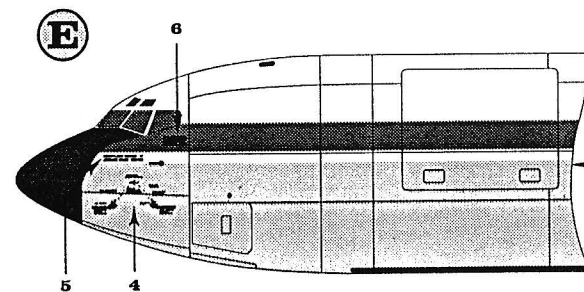

KC-135A 59-1491/N930NA, NASA Ellington, Houston, TX, 1986. Lower fuselage, wings, and horizontal stabilizers F.S. 16473, fuselage top white, cheatline medium blue (approx. F.S. 15102). Engine center cowl areas and pylons white. Radome and anti-glare panel flat black.

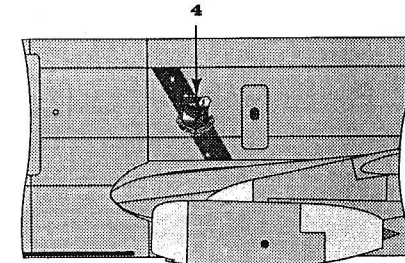

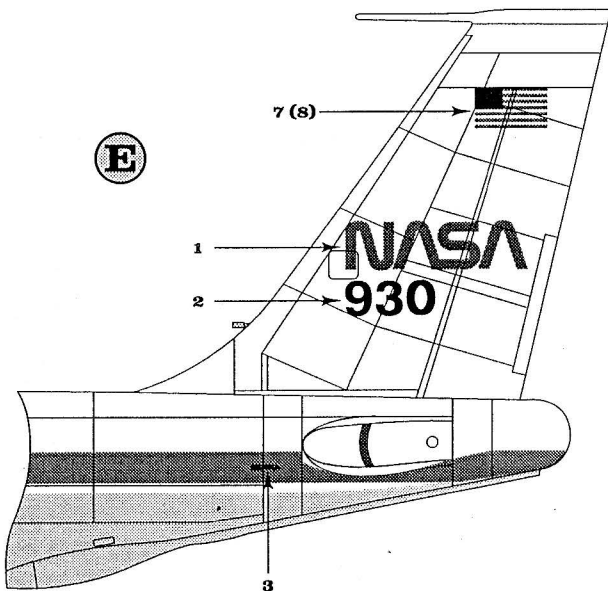
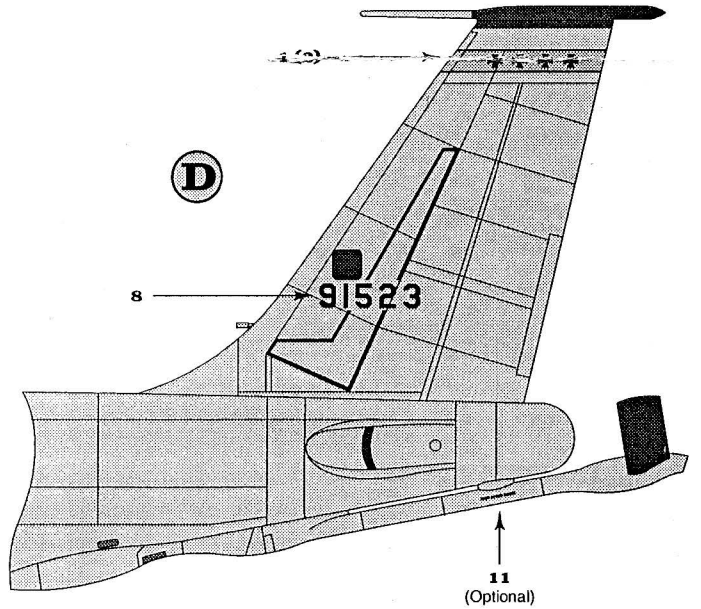
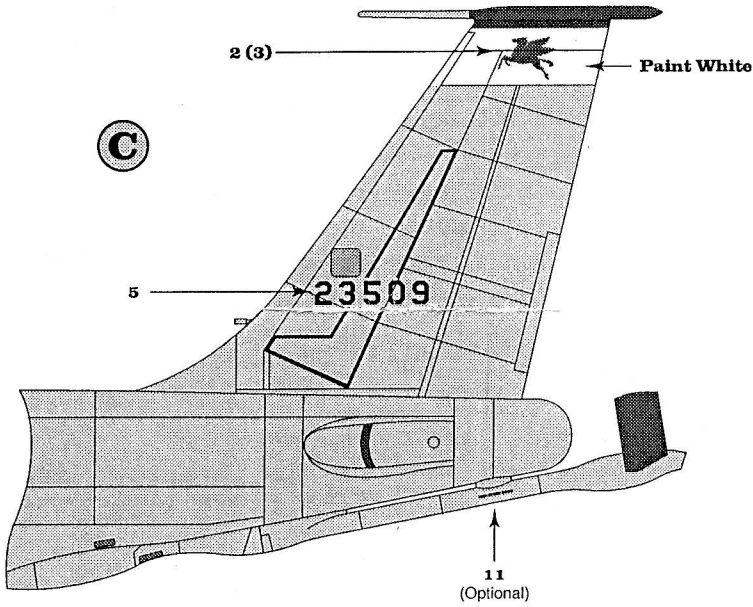
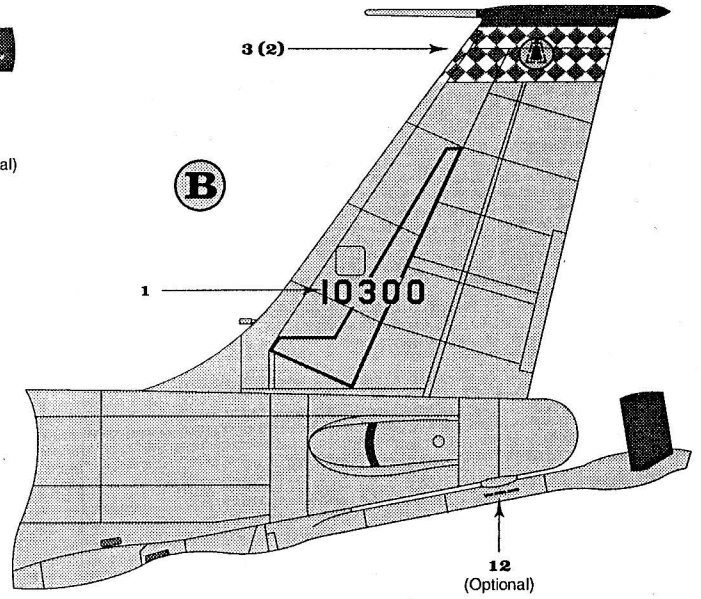
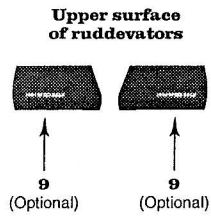
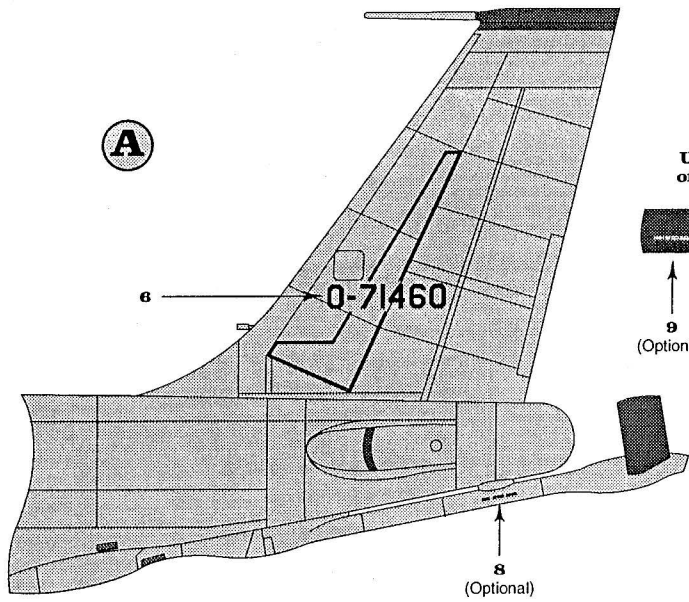

**Note:**  
 NASA 930 is a KC-135A  
 but operates without a  
 refueling boom. Modifications  
 to the kit are required.

**Thanks to the following for  
 their assistance and support:**

**Brian Nicklas  
 Randy Walker  
 Joe Bruch  
 Bill Fields  
 Dana Bell**