



Belcher Bits BK10: North American NJ

The first of 40 North American NJ-1, NAS Pensacola, 1937.

Introduction

North American's NA-16 trainer was the sire of a long line of military trainers, the AT-6 Texan being the most famous. However, there were many other variations on the same airframe.

The NJ was procured for the US Navy as a flight and instrument trainer, a total of 40 being built. It was similar in construction to the current USAAC trainer, the BT-9 but differed in that it used the larger R-

1340 engine that was eventually standardized on North American trainers, although uniquely, this variant had two exhaust ports at the bottom of the engine.

The Kit

This kit includes a complete Occidental Harvard Mk II kit, necessary resin parts to convert the kit to an NJ, a set of EZ Mask canopy masks and a set of decals with schemes for two USN NJ-1s.

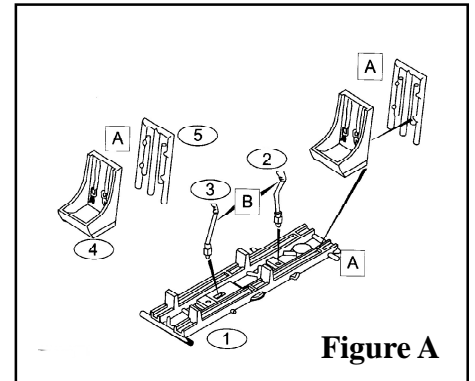
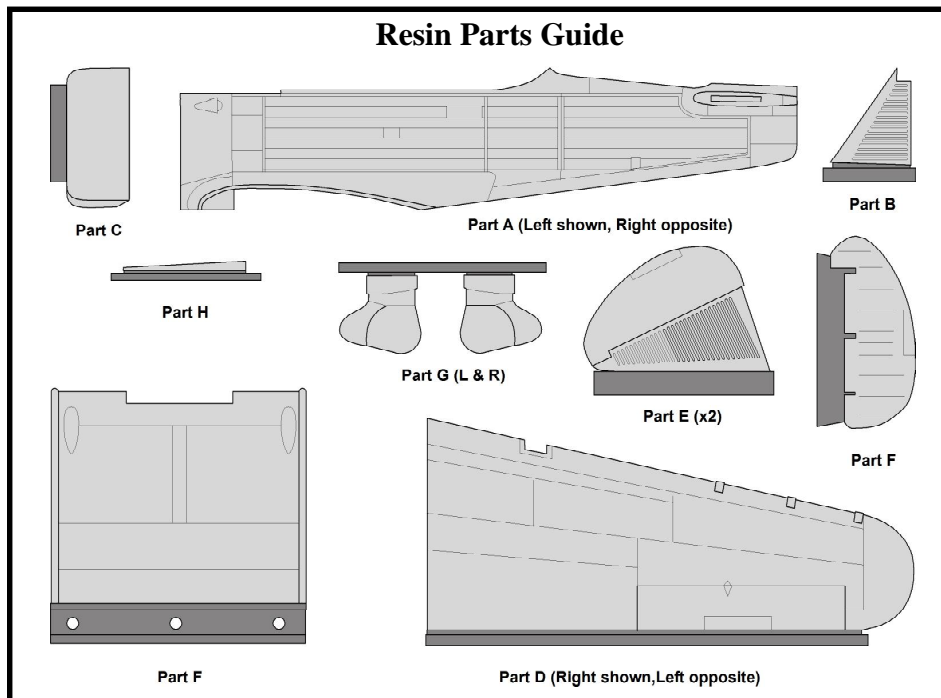

Figure A



Fuselage

Early NA trainers had what is known as a short-arm rear fuselage, which was 6" shorter than the later T-6. The difference in length is all at the after end. The elevators are actually in the same location relative to the wing, but the later long-arm fuselages moved the vertical fin back 6 inches. Furthermore, these early machines all had the fabric sided fuselages. Just for interest's sake there were a couple later variants which had a metal covered short fuselage, but all long fuselages were metal covered. Assemble the kit interior, using Figs A and B. Interior colour is interior green with aluminum lacquer rollover structure. Seats would have been bare metal; the pilots used seat pack parachutes. Paint the instrument panels and side consoles black; the instruments can be picked out with a white pencil, or by careful drybrushing.

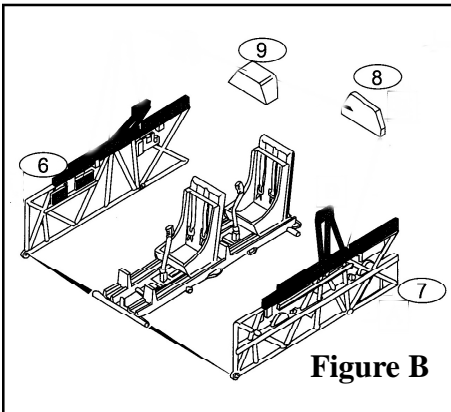

Figure B

Glue the resin fuselage halves (Parts A) together with the upper cowling piece (part 15) and forward instrument panel (part 12) using Fig. C. Kit part 10 will need a little trimming to allow the fuselage halves to mate properly. When you glue on part 15 so the panel lines up, it will protrude beyond the front of the fuselage a bit, so that must be trimmed. There will also be a small gap at the leading edge of the canopy rail. Fill this gap with small scraps of plastic because the canopy will not fit if you glue part 15 further back. I would also recommend leaving off the tailwheel until the end.

The resin fuselage will require substantial grinding or filing on the bottom to fit well with the centre section. Best to do this at this stage so you can test fit the centre section easily.

Engine Assembly

I have built several of these kits and one weakness is the fit of the cowling and the engine. I find the engine sits too far forward, and the attachment of the cowling is a bit undefined. I recommend that you sand down the exhaust stubs on part 19 so that the thickness is 0.156" (4mm), and trim the ring on the back of part 20 so that it fits to part 19. This will shorten the whole engine assembly enough so that it doesn't stick out too far into the cowling.

Because the NJ used a fixed gear un-

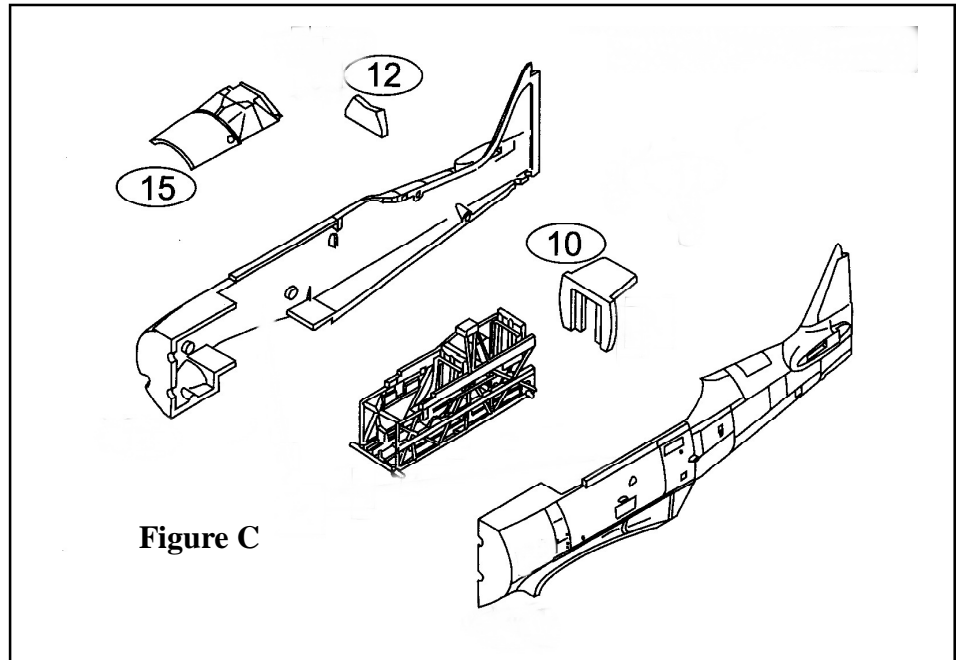

Figure C

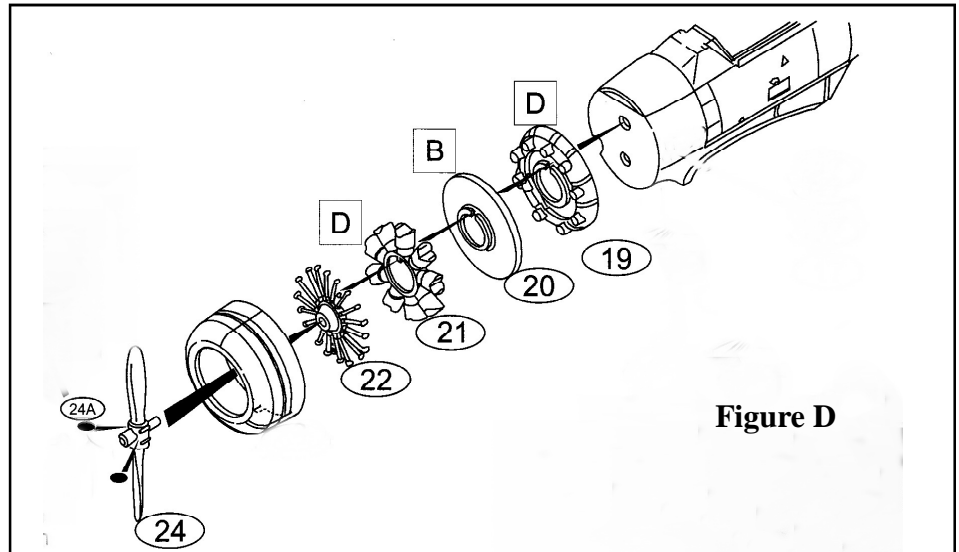

Figure D

dercarriage, the wheel well stubs on the resin fuselage parts will need to be removed. Reinforce the area behind these inside the nose with some cyano glue before gluing on the engine assembly. You can file these down somewhat now but save any filling for after the attachment of the wing.

Now, glue part 19 to part 20 and then glue these to the front of the resin fuselage halves. There will be a step, but fair it in with some putty. When the cowling goes on, this area will be in the gap between the cowling and the fuselage.

Cowling

You can assemble and paint the engine separately, and glue the cowling on after all other painting has been done. The interior of the cowling was also probably natural metal, but could have been zinc chromate primer. Remove the moulding ring from the front cowling and sand the cowling lip to a smooth radius. Open up the two slots in the bottom of the cowling. There are 3 'fingers' moulded inside the cowling and these are used to support it against part 20 when it is installed. Note that the top two

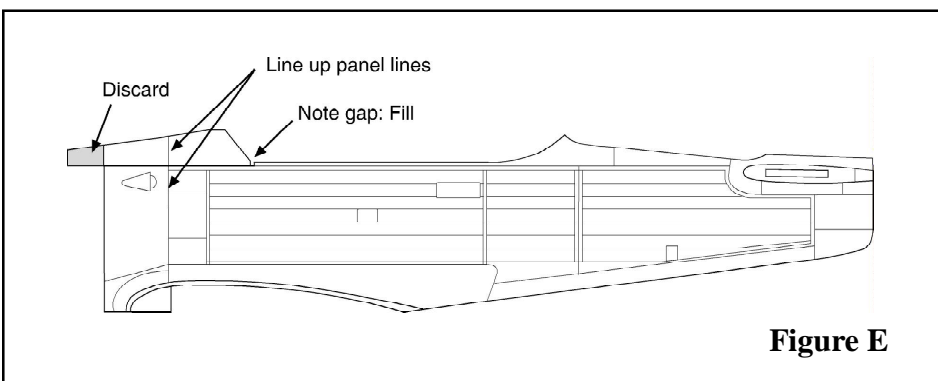

Figure E

fingers go on either side of the top center cylinder. If all goes well at final assembly, there should be about a 1/16" (1.5mm) gap behind the cowling.

Wing

A word on wings. The first trainers had a nasty tip stall. One early fix was to fit slats on the outer wing leading edges. This helped, but the problem still existed. Later, the wings were de-skinned, the structure twisted down 2 degrees at the tip and new wing skins installed. The problem was only ever solved with the 'new' wing first seen on the AT-6 which had the twist built in and had a small sweep-forward to the trailing edge.

The NJ like the BT-9s had the old style wing with a straight trailing edge. However, it did not use the leading edge slats so file off the protruberances on the wing leading edge and sand smooth. For this model, we will use the resin centre section with resin outer wings.

I recommend doing the wing separately from the fuselage since it involves gluing the outer wing panels to a centre section, it will be easier to ensure the same dihedral on both wings. Glue the kit wings (parts 32,33,34 and the flaps 31) together and when dry, cut them off flush with the outside edge of the fairing strip. Glue the outer wing panels (resin part C) to the centre section. I find the best way to do this is to tape the centre section down securely and use modelling clay to support the outer wing in position. Tack in place with cyanoacrylate glue. Once satisfied both outer wings are correct, flow some more cyano in the joint and fill any gaps with putty. Note that the outer wing parts are centred vertically on the butt edge but the trailing edges are in line. If you want to drop flaps, you are in for a world of work and on your own.

When dry, fit the completed wing to the fuselage. Some filling will be required at the joint between the wing and the fuselage along the root.

Tail Area

I recommended doing the wings first, so that when you come to glue on the tail parts, it will be easy to line everything either in line or at right angles. The vertical fin (resin part B) is glued in place, lining up the after edge with the end of the fuselage. File that surface flat, test fit the rudder and glue it in place.

The port and starboard resin tailplanes

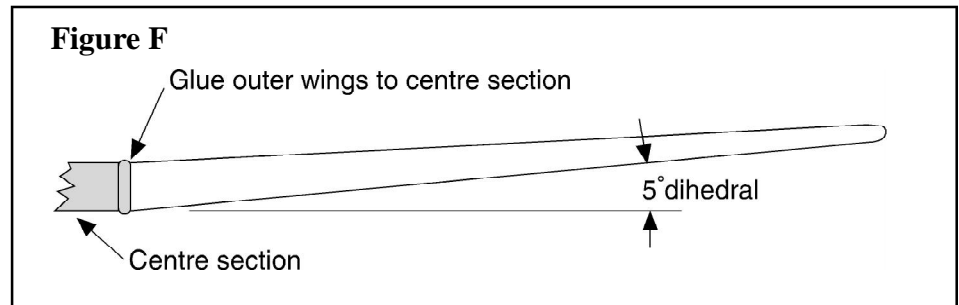

(resin part E) can be glued in place and seams filled. Remember these should be parallel to the wing centre section.

Landing Gear

All the photos I have seen of Navy NJs showed full spats, unlike many BT-9s which had the lower section removed. Note the open sections face outboard.

Cut off the spats (resin parts G) from their base and paint. The Occidental kit provides three tires, one with a diamond tread pattern. Toss it in the spare box, and sand the line tread patterns off the other two tires ... if you can reduce their width slightly, they will look better. Reduce the thickness of the wheels (part 35) by sanding the back face. The wheels covers (part 36) can be reversed and painted separately from the tire. The final step is to glue the tire into the spat.

The tail wheel from the kit (part 11) is used but with modification. Cut off the mounting pins and the rear section aft of the tailwheel strut. Sand the top flat and glue in position where indicated on the drawing.

Canopy

Depending on the way you like to deal with canopies, you may want to fit the fixed portions such as the windscreen (part 49) and the rear canopy section (part 53a) prior to painting. The Occidental kit includes optional canopy sections for early and later Harvards; be sure to use the early ones with the additional canopy frames; kit parts 50a (front), 51a (middle) and 52a (rear).

This kit includes a set of EZ Mask canopy masks for your convenience. This self-adhesive film is pre-cut to fit the Occidental kit canopy, and will definitely save you time in masking. Mix a small amount of detergent with water, use a sharp knife to lift the canopy mask section off the backing and a pair of tweezers to dip it in the soapy water. Place it where indicated on the canopy; the soapy water will allow you to move it into position. Once the mask is properly positioned, press it in place and pat it dry. Once all the masks are positioned and

dried, the canopy is ready for painting.

Final Steps

Following painting, clear wing landing light covers part 48 (starboard) and 48a (port) are glued in place on the port and starboard wings respectively. The Occidental kit does not make any attempt to show the lamps; these could be made from small bits of sprue or railroad lamp lenses.

NJs used a tall antenna mast fitted on the forward cowling area, just to the port side of the centreline. Fit resin part N after all other work is completed to avoid breaking during handling.

On the starboard side just aft of the accessory section are two small venturi. Too small for resin parts, you should make these up from stretched sprue ends.

Glue the pitch control weights (parts 24A) to the kit prop (part 24) hub. The prop is natural metal with black on the rear faces of the blades.

References:

1. **North American Aircraft 1934-1998 Vol. 1**, by Norm Avery, published by Narkeiwicz / Thompson
2. **North American NA-16/AT-6/SNJ**, Warbird Tech Series Volume 11, by Dan Hagedorn, published by Specialty Press
3. **T-6 Texan in Action**, by Larry Davis, Squadron/Signal Publications.
4. **Harvard!** by Dave Fletcher and Doug Macphail, published by DCF Flying Books.
5. **The Incredible T-6 Pilot Maker** by W. Ohlrich and J. Ethell, published by Specialty Press, 1983.
6. **North American's T-6** by Dan Hagedorn, published by Specialty Pres, 2009

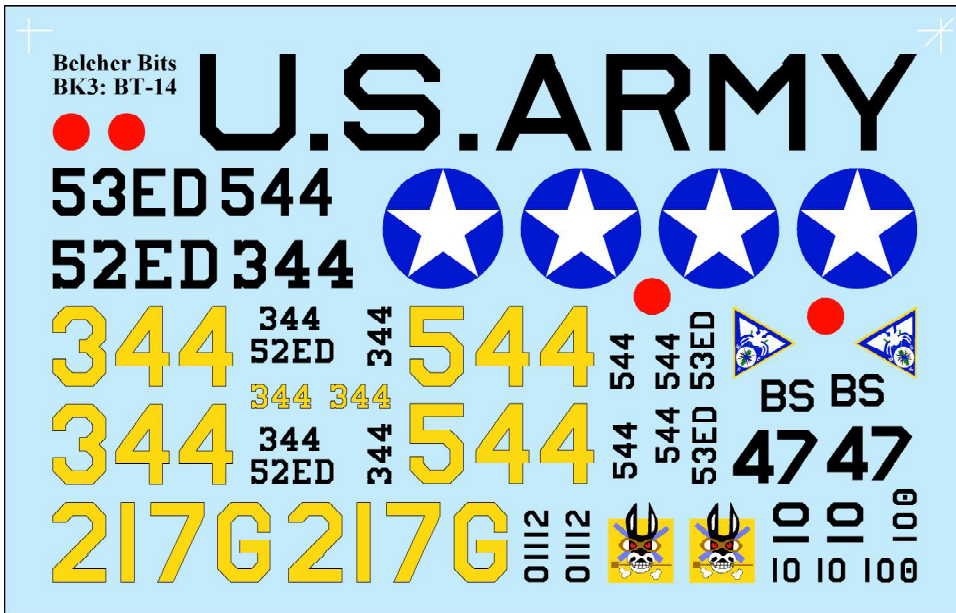

Use the roundels for the upper and lower wings. The rest of the markings on this sheet are not applicable to the NJ.
 The small strip below contains specific markings for two NJ aircraft. Note the two different styles of U.S. NAVY; the more elongated one was used on the earlier plane with the red nose.

Decal Guide

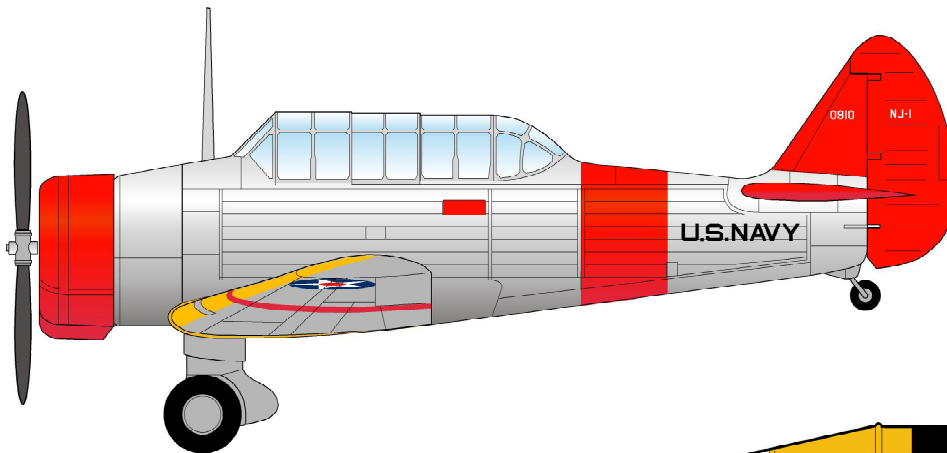

North American NJ, s/n 0910, NAS Pensacola, 1937

The first NJ delivered in instrument trainer markings (red nose, and fuselage bands, wing bands). Overall painted aluminum with yellow wing tops (wrapped around the leading edge about 6"). Red vertical fin and horizontal tail. The fuselage band is 30" wide, the wing bands are 24" wide. Roundels top and bottom of wings. Fire extinguisher panel was red with black lettering.

Ref: Warbird Tech, p.23

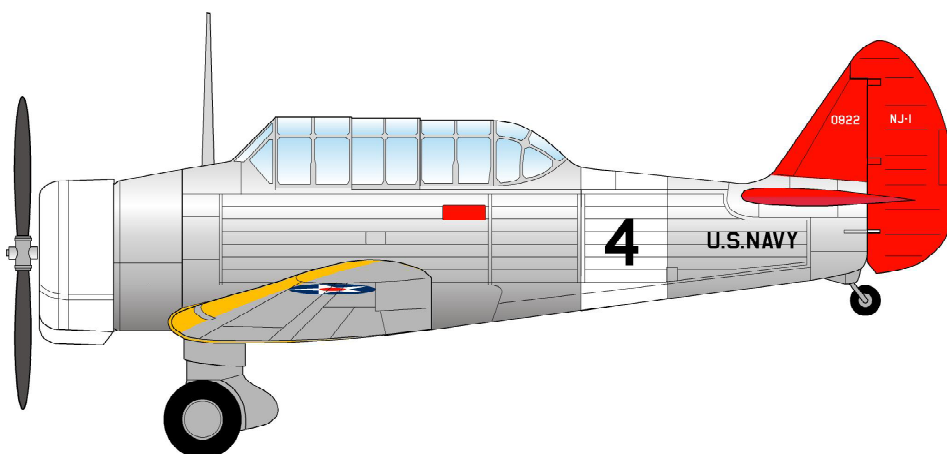
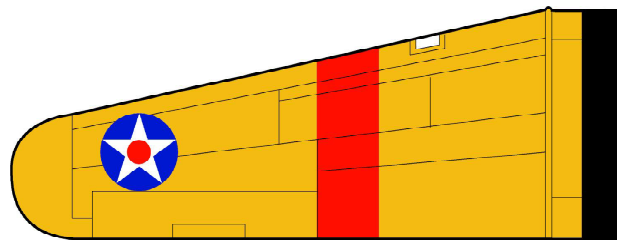

North American NJ, s/n 0922, NAS Pensacola, 1938

Overall painted aluminum with yellow wing tops (wrapped around the leading edge about 6"). Red vertical fin and horizontal tail. The white fuselage band is 30" wide, no wing bands. Roundels top and bottom of wings. Fire extinguisher panel was red with black lettering.

Ref: Warbird Tech, p.24