

SCALE  
1/48  
**TOMAHAWK IIb**  
"Ace of African Front"

ACADEMY  
HOBBY MODEL KITS

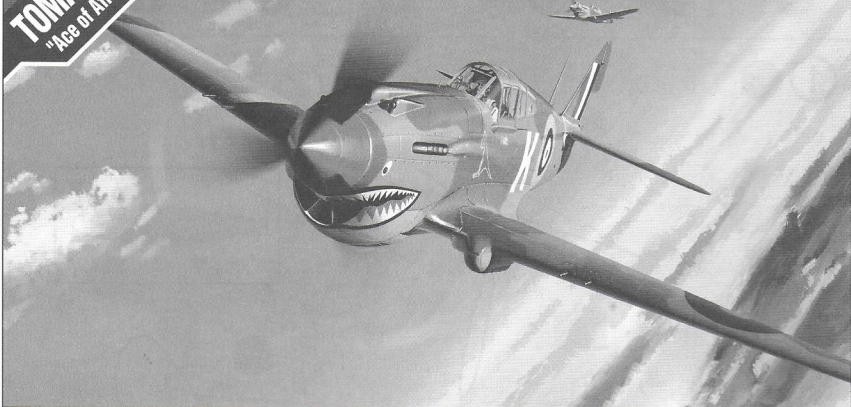

12235

	OSI CODES	MARKET CODES	Life COLOR	NUMBERS	TUTOR, MODEL, PARTS				
	FS 36110	FS 11130	LC06	19	2041	4714			
▽	RED	FS 11130	H<327>	327	LC06	19	2041	4714	빨간색
▽	YELLOW	FS 36830	H<328>	329	LC03	69	2063	4721	노랑색
▽	FLAT BLACK	H<12>	33	LC02	33	1749	4768		무광 검정색
▽	AZURE BLUE	370	UA098	109	2048				아주빛 블루
▽	METALLIC GRAY	H<28>	61	LC76	53	1795	4681		메탈릭 그레이
▽	SILVER	H<8>	8	LC74	11	1790	4678		은색
▽	BURNT IRON	H<38>	61	LC26	53	1795	4681		번트 아이언
▽	MIDDLE STONE	H<71>	21	UA097	225	2052			미들 스톤
▽	DARK EARTH	FS 36110	H<72>	369	UA092	29	2054		다크 어스

**<READ THIS BEFORE YOU BEGIN>**

- Study the instructions before assembling. Check the fit of each piece before cementing into place.
- Do not use too much cement to join parts. Never use cement or paint near open flame.
- Open a window or make area well ventilated when cement or paint is in use.
- Tear up and throw away the empty plastic bags to avoid danger of suffocation for little children.

**<ALLGEMEINE HINWEISE>**

- Die Anordnung der Bauteile ist aus den Zeichnungen der Anleitung ersichtlich.
- Die Teile vor dem Verkleben angelegt zusammenhalten, um ihren paß zu prüfen.
- Klebstoff nicht zu dick auftragen. Klebstoff und Farben niemals in der Nähe einer Flamme verwenden.
- Während der Bemalung mit Spritzspalte oder Pinsel für frische Luftzufuhr, z.B. Öffnen des Fensters, sorgen.
- Bausatz von kleinen Kindern fernhalten. Verhüten Sie, daß Kinder irgendwelche Bauteile in den Mund nehmen oder Plastikfolien über den Kopf ziehen.

**■ 조립하기 전에**

- 부품을 조립하기 전에 설명서를 잘 읽어본 후 조립한다. - 부품을 지를 때에는 접합이 나빠질 여지가 없도록 한다. - 설명서를 사용할 곳에 사용하지 않는 곳에 유의하고 너무 많이 바르지 않도록 한다.
- 설명하기 전에 부품을 맞추어 확인한 후 조립한다. - 에너를 확인한 후 설명서를 사용할 때는 창문을 열어 환기를 시키고 화기를 멀리한다. - 사용 후 남은 부품은 어린이 어린이의 손에 닿지 않도록 잘 처리한다.



**<LISEZ CE QUI SUIT AVANT DE COMMENCER LE MONTAGE>**

- Étudier les schémas d'assemblage. Contrôler que chaque pièce soit bien conforme avant de la coller à sa place.
- N'utiliser pas trop de colle pour réunir les pièces. Ne jamais manipuler la colle ou peinture à proximité d'une flamme.
- Aérer soigneusement la pièce où vous peignez/coulez la peinture.
- Éloigner le matériel des enfants et des animaux. Éviter que les enfants ne mettent sur la tête et ne suffoquent.

**〈読み立てる前に〉**

- 組み立てる前に説明書をよく読み、各パーツが正しく適合しているかを確認してください。
- 接着剤を多量に塗ると接着不良の原因となります。また、接着剤や塗料を火のそばで扱うことは危険です。また、塗料や接着剤を子供や動物の手の届くところに置かないでください。
- 塗装や塗料を使用する時はほとんども窓を開けて換気をよくしましょう。
- 組み立て後の部品やニールを子供や動物の手の届くところに置かないでください。

**▲ 보조자 분들은 반드시 읽어 주십시오.**

- 조립하기 전에 취급 설명서를 잘 읽어 내용을 충분히 이해한 상태에서 조립해야 합니다.
- 부품을 지를 때는 접합이 나빠질 여지가 없도록 합니다. - 설명서를 사용할 곳에 사용하지 않는 곳에 유의하고 너무 많이 바르지 않도록 합니다.
- 작은 부품을 다룰 때는 창문이나 환기 시설이 잘 되어 있는 곳에서 작업하십시오. - 설명서 사용 시 창문을 열어 환기를 시키고 화기를 멀리하십시오. - 사용 후 남은 부품은 어린이 어린이의 손에 닿지 않도록 잘 처리하십시오.
- 재료 및 부품이 포장된 비닐봉지는 개봉 후 즉시 어린이의 손에 닿지 않는 곳에 잘 보관하십시오. - 설명서 사용 시 창문을 열어 환기를 시키고 화기를 멀리하십시오. - 사용 후 남은 부품은 어린이 어린이의 손에 닿지 않는 곳에 잘 보관하십시오.



**주의  
WARNING!**

- Before starting to assemble, read the instruction manual very carefully to understand well everything of the instructions.
- Before cutting a part off sharp, check the part number again and use proper tool such as nipper to cut it clearly. Take care not to be hurt in use of modeling liquids to cut or trim parts.
- Never put small parts in the mouth to avoid any danger of suffocation by accidentally swallowed ones. • Never let children less than 3 years old have it to avoid any danger of taking it.
- The product may have some protruding parts for functional reasons and take care of handling it always.
- After cutting a part off sharp, trim it clearly to assemble and the wastes should be properly sorted to dispose.
- Plastic bags packed with the product and parts should be disposed in a proper place immediately to keep out of children to avoid any danger of suffocation by pulling it over head or pulling it over face.
- Before using modeling colors or cement, open windows to keep the room well ventilated and do not use near fire or flame. After using them, keep in a proper place out of children.



1

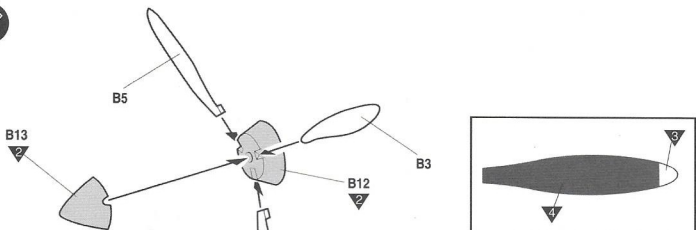

2

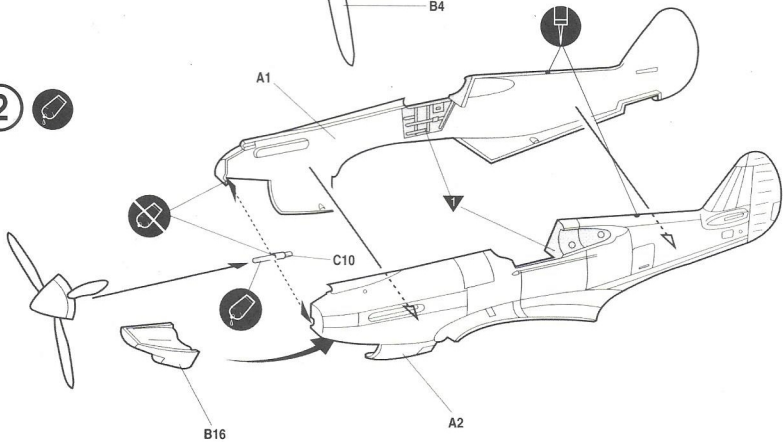

3

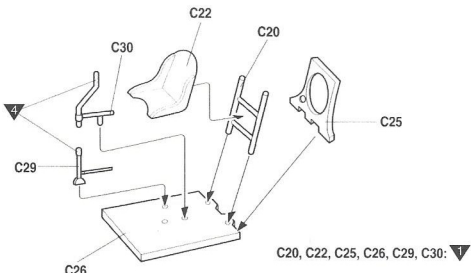

4

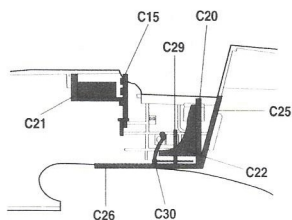
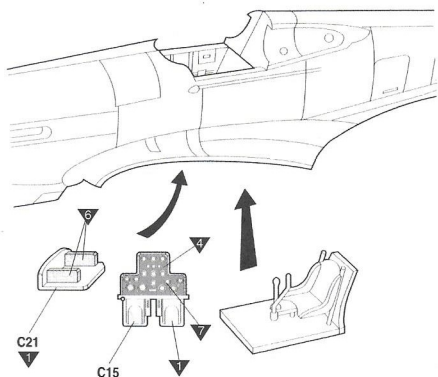

5

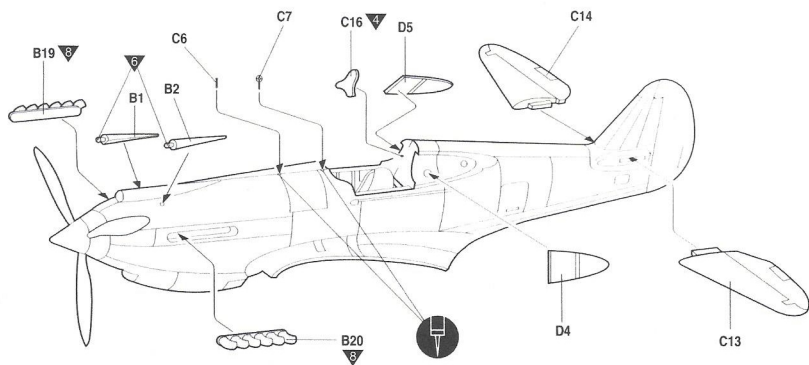

6

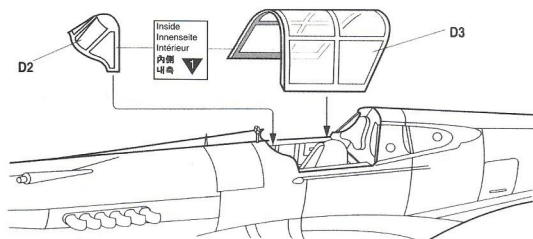

7

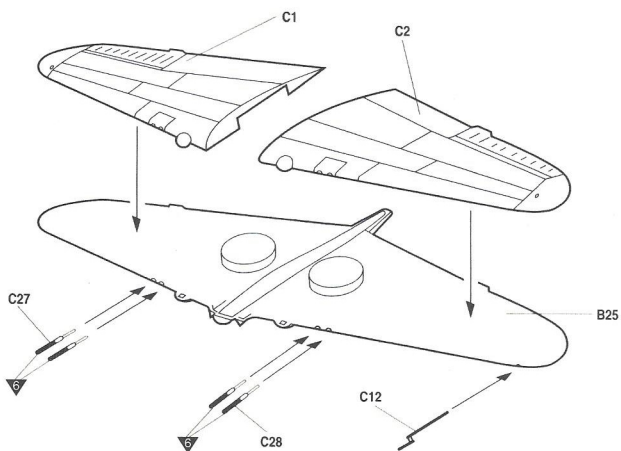

8

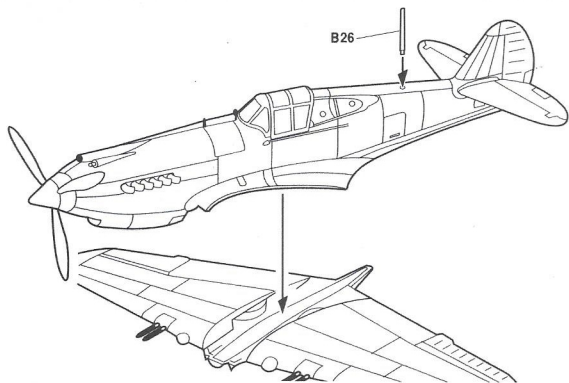

B26

9

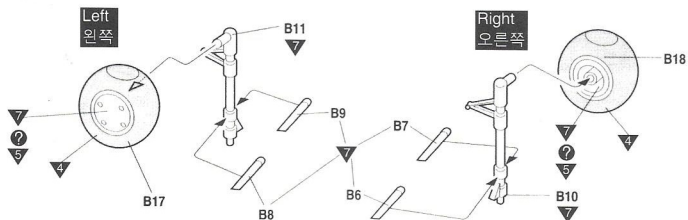

Left  
왼쪽

Right  
오른쪽

10

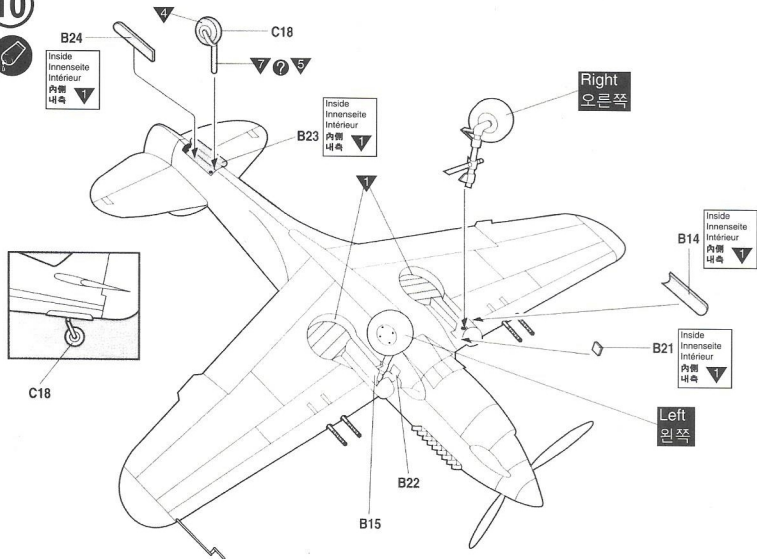

B24  
Inside  
Innenseite  
Intérieur  
내측

B23  
Inside  
Innenseite  
Intérieur  
내측

Right  
오른쪽

B14  
Inside  
Innenseite  
Intérieur  
내측

B21  
Inside  
Innenseite  
Intérieur  
내측

Left  
왼쪽

C18

B15

- 1** Tomahawk IIb, AN413, RAF Plt Off Jack Bartle of No. 112 "SHAR" Sqn, Egypt, Oct. 1941.  
 토마호크 IIb AN413, 이집트주둔 영연방공군 제112 "샤크" 비행대 소속, 잭 바틀 소위 탑승기, 1941년 10월.

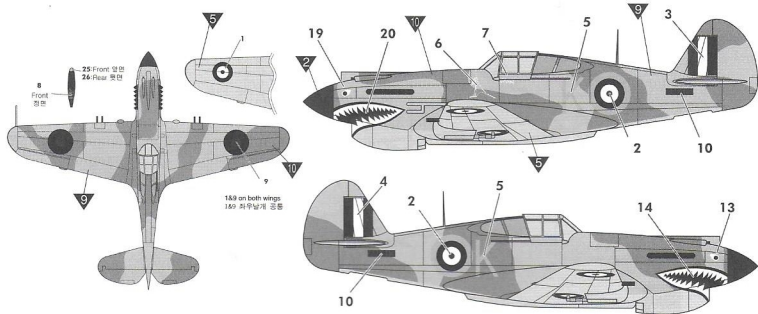

Jack Bartle, Australian Ace with 6 kills remotes to be Plt Lt and No. 112 Sqn, commander after Plt Lt Clive Caldwell in May, 1942. 6기격추기록을 가지는 호주출신의 에이스 잭 바틀은 1942년 5월 클리브 칼드웰 소령의 뒤를 이어 소령진급과 함께 112비행대의 지휘를 맡는다.

- 2** Tomahawk IIb, AK498, RAF Flt Lt Clive Caldwell of No. 250 "SUDAN" Sqn, Lybia, Nov-Dec. 1941.  
 토마호크 IIb AK498, 리비아주둔 영연방공군 제250 "수단" 비행대 소속, 클리브 칼드웰 소령 탑승기, 1941년 11~12월.

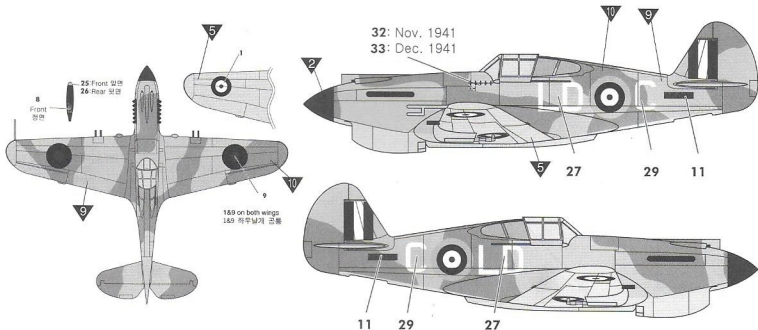

Group Captain Clive Caldwell, an Australian Hero Ace with 28.5 kills, was assigned to Sqn No.250 when he shot down 5 Ju-87 Stukas at one combat in Dec, 1941. In late 1942 he was sent back to RAAF to fight against Japanese threat on Pacific Theatre, flying Spitfires.

최종계급 대령인 클리브 칼드웰 역시 호주인으로, 호주출신 조종사 가운데 최고기록인 28.5기의 기록을 갖는다. 250비행대 소속으로 리비아에 전개중이던 1941년 12월 5일 한 번의 전투에서 5기의 Ju-87 슈투카를 격추시킨다. 이후 호주공군으로 복귀하여 태평양전쟁에서 스피트ไฟ어로 일본군과 싸웠다.

- 3** Tomahawk IIb, AK402, RAF P/O Neville Duke of No. 112 "SHARK" Sqn, Egypt, Nov. 1941.  
 토마호크 IIb AK402, 이집트주둔 영연방공군 제112 "사크" 비행대소속, 네빌 듀크 소위 탑승기, 1941년 11월.

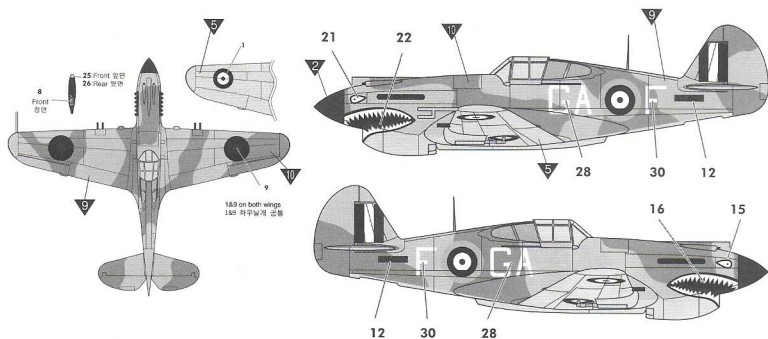

- 4** Tomahawk IIb, AK578, RAF P/O Neville Duke of No. 112 "SHARK" Sqn, Egypt, Jan-Feb. 1942.  
 토마호크 IIb AK578, 이집트주둔 영연방공군 제112 "사크" 비행대소속, 네빌 듀크 소위 탑승기, 1942년 1-2월

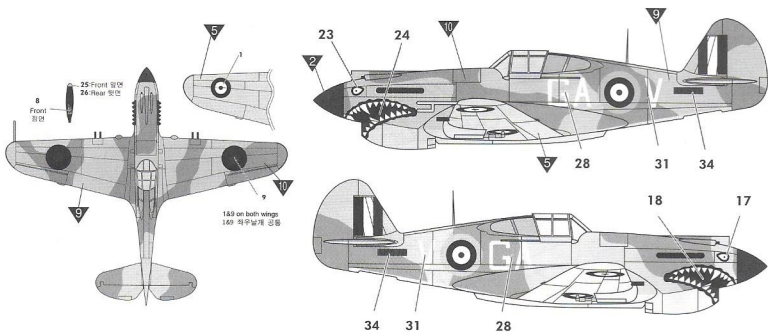

Squadron Leader Neville Fredrick Duke, scoring at least 27, was 19 when he became ace on 30, Nov, 1941 on AK402, finishing the flight by being shot down by German Ace, Otto Schulz. He kept flying mainly in AK578 and Kittyhawk, Spitfires, to be a Mediterranean Theatre's top Allied fighter ace. Later he worked for Hawker as a test pilot, recording top speed with Hunter.

최종계급 대령인 네빌 프레드릭 듀크가 AK402를 조종하며 다섯번째 격추를 기록, 에이스가 되던 1941년 11월 30일 그는 아직 19세였으며, 그 비행은 독일공군의 에이스인 오토 슐츠에게 격추당하는 것으로 끝나버렸다.

그럼에도 아래의 AK578 및 키티호크, 스피파이어 등을 조종하며 지중해전선의 연합군 최고 에이스에까지 이른다. 이후 호커사의 시험조종사로 근무하였고, 헌터를 조종하여 세계최고속도를 기록하기도 한다.

**A**

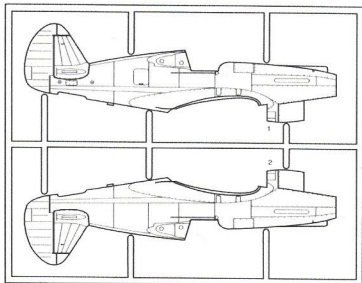

**D**

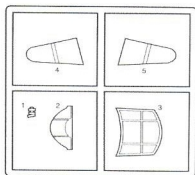

**B**

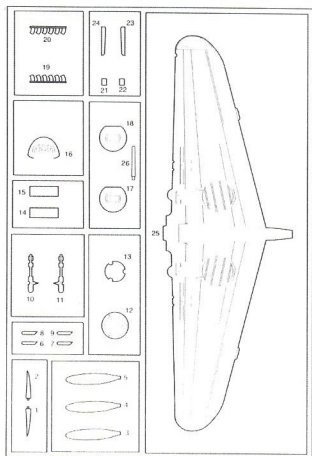

**C**

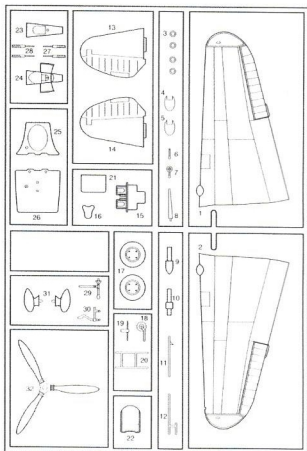

● Decal/전사지

● Unused parts/불필요 부품  
C3, C4, C5, C8, C9, C11, C17, C19  
C23, C24, C31, C32, D1

**ACADEMY**  
HOBBY MODEL KITS

**ACADEMY**  
ACADEMY PLASTIC MODEL CO., LTD.  
521-1, Yangcheon-dong, Ulsanju-bu-si, Gyeonggi-do, Korea  
고객상담센터: 096-969-7000