

32001

產品編號: 32001

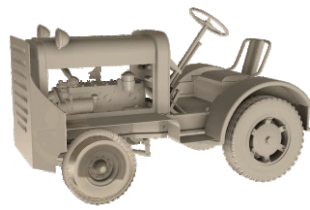

scale 1/32

1:32 比例

1/32 US Army Tug Clarktor-6 Mill-33

Go through this assembly guide and understand it before you start kit assembly
 Use usual plastic kit's cements (Tamiya Extra Thin) and tools (not included in the kit)
 Follow painting guide supplied, use only hobby paints
 Work carefully with photo etched parts if included, use C/A glues to assemble them

請您在組裝此產品前仔細閱讀組裝指南;
 請使用通用塑膠模型黏合劑和工具(本產品不附帶);
 本產品所以提供的噴塗指南只適用本於模型;
 如果本產品含有蝕刻套件,請小心仔細處理, 請使用C/A膠水組裝;

組み立て前にこの組み立てガイドをご覧ください。
 プラスチックキット専用接着剤と専用工具をご使用ください。(ともにキットには含まれていません)
 塗装ガイドに従ってください。専用塗料をご使用ください。
 エッチングパーツの組み立ては細かいパーツのため注意が必要です。また接着には瞬間接着剤を使用してください。



cut/remove

切下 / 移除

切断/切り離し



drill hole

鑽孔

ドリル穴



no glue

不適用膠水

接着しない



bend

折彎

折り曲げ



cyanoacrylate glue

氰基丙烯酸酯膠水

瞬間接着剤



string or wire

細繩或者金屬絲線

糸または金属線



rope

繩

ひも



PE - press rivets (lines)
from the etched off side

蝕刻片 -
請从蚀刻掉的一侧压铆钉 (线)

ラインやリベット部分を未エッチング面から圧を与える

Production of the Clarktor-6 began in 1942 and ended in 1966. Between 1941 to 1945, CLARK produced almost 90 percent of the military requirements for fork lift trucks and tow tractors. During WWII there was not an air field under Allied control that did not have a CLARK tow tractor. The Clarktor 6 was powered by a water-cooled Chrysler six-cylinder 230-cid flathead gasoline engine of 6 2hp, with a three-speed gearbox that could reach a maximum speed of 15 mph. Production began in 1942, and by the end of the war Clark had delivered thousands of different cargo handling vehicles, including an order for more than 1,500 Clarktor 6s for the British Royal Air Force. These were built as a version designated "BH", standing for 'British Heavy', and supplied to Ministry of War Transport for the RAF under the Lend Lease Act. Mill-33 is the lighter variant of the tug, with single rear wheels, and a drawbar capacity of over 2 tons and a towing capacity of 90 tons, allowing it to handle all types of bomb trailers and aircraft, including the heavy bomber aircraft in service with the USAAF and the RAF

1

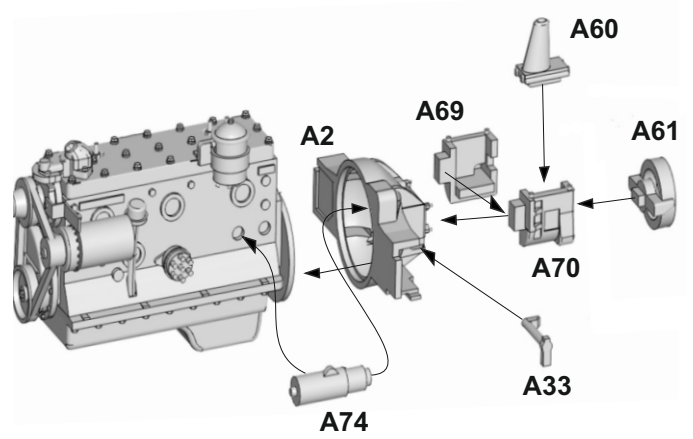
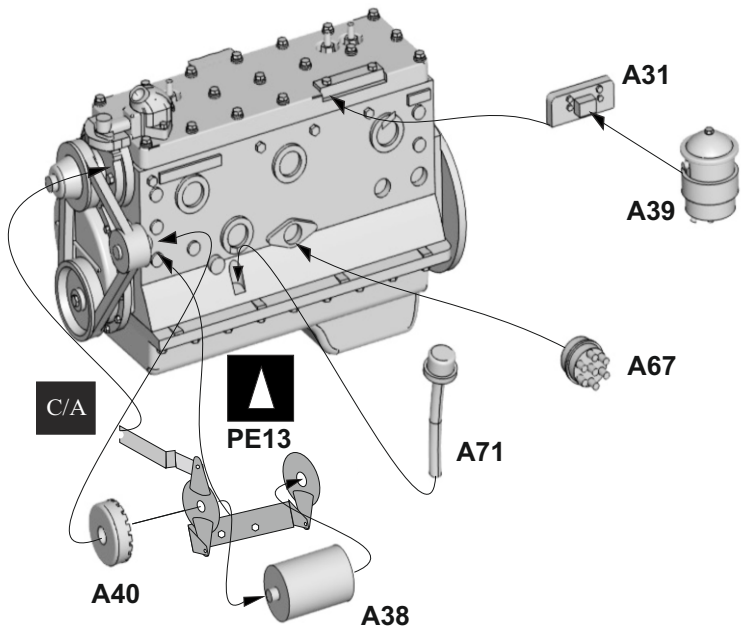
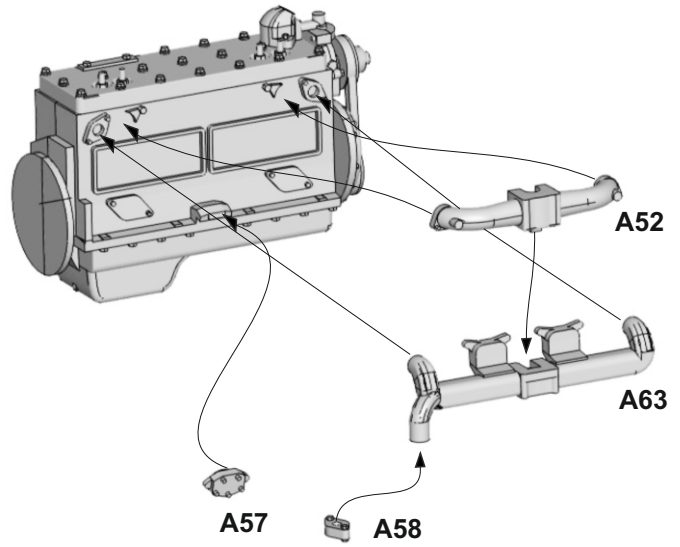
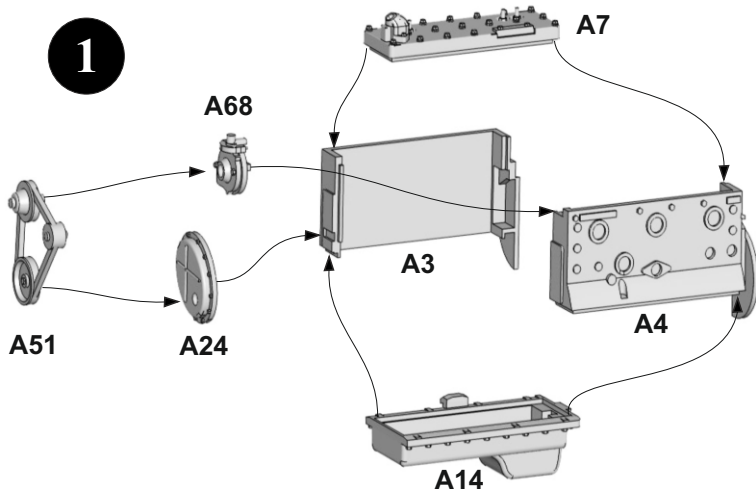

2

2

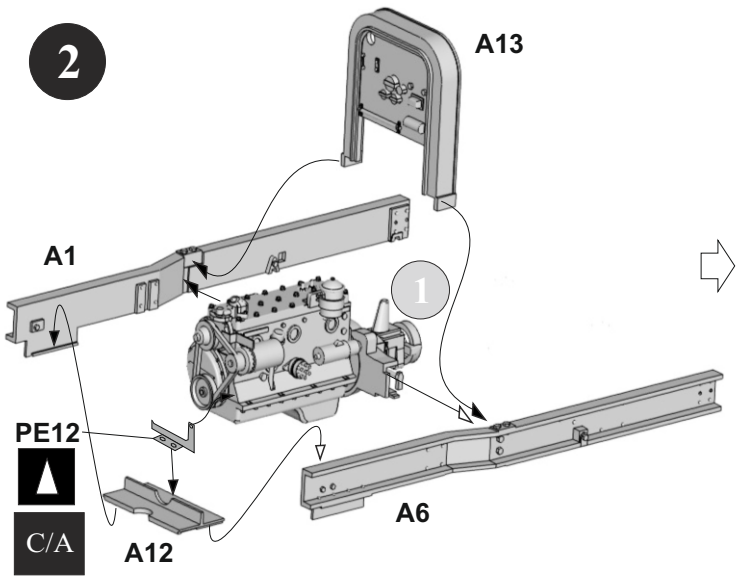

USE A15 TO DRY-FIT ANGLES AND CORRECT POSITION

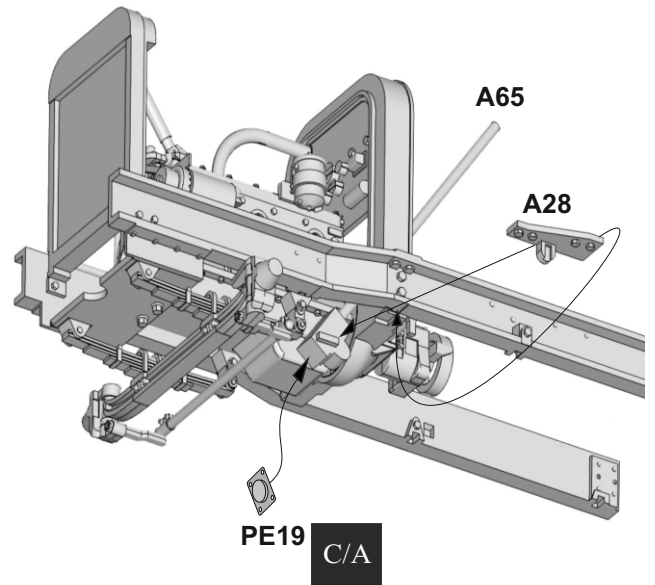
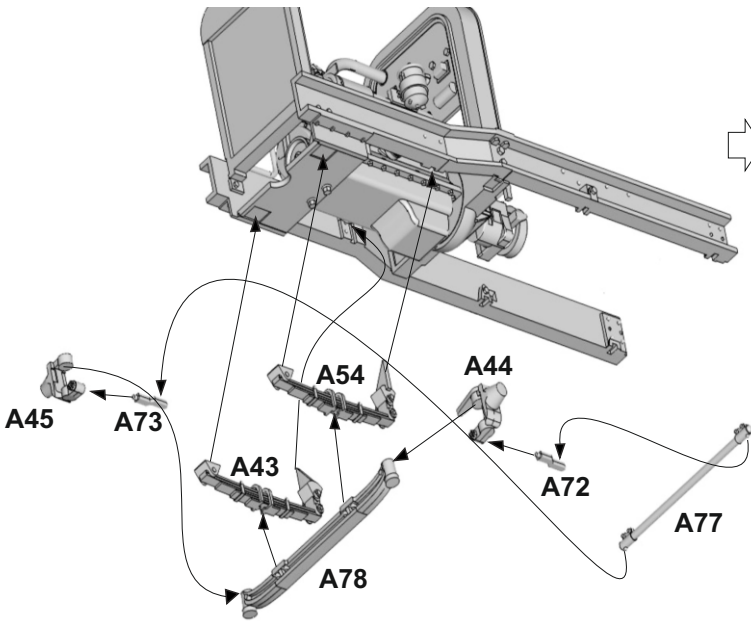
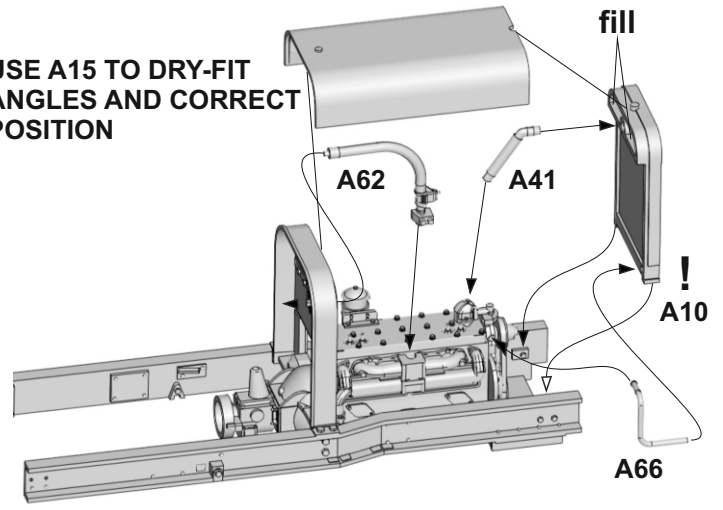

3

3

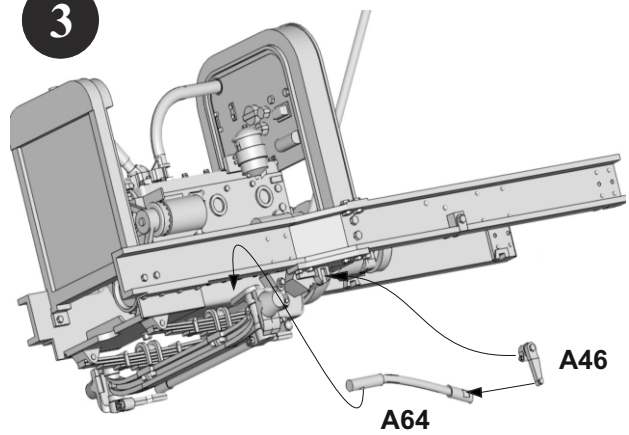

4

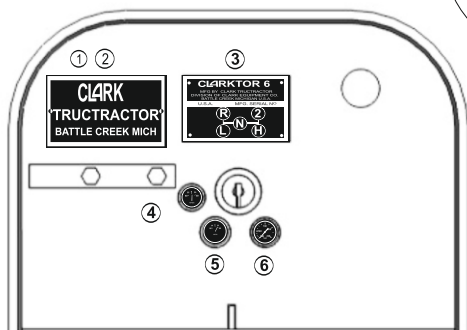
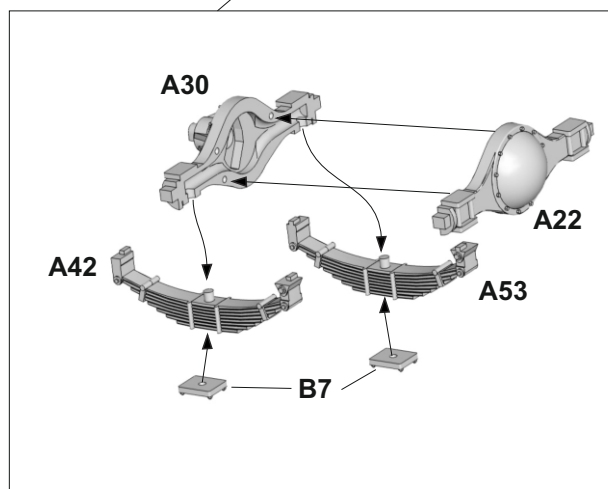
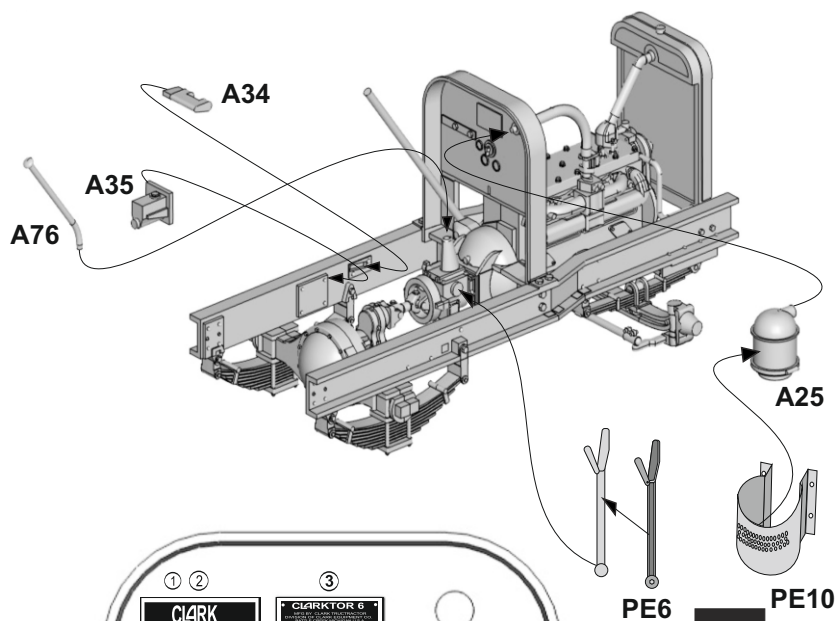
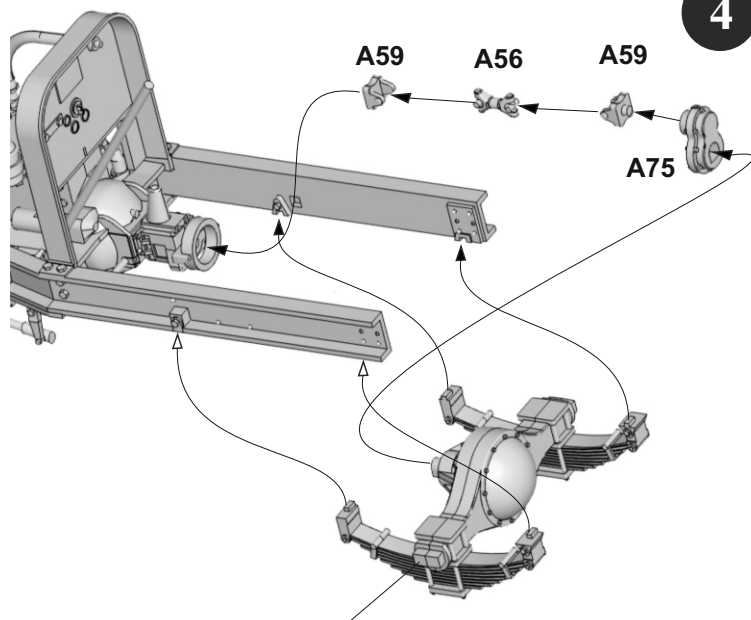

INSTRUMENT DECALS PLACEMENT over Black Background

C/A

4

5

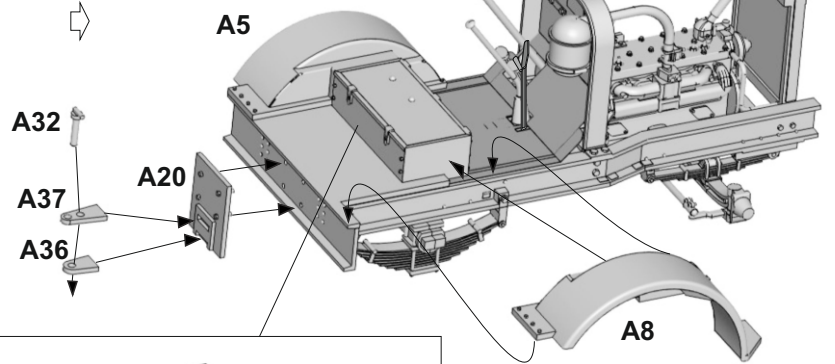
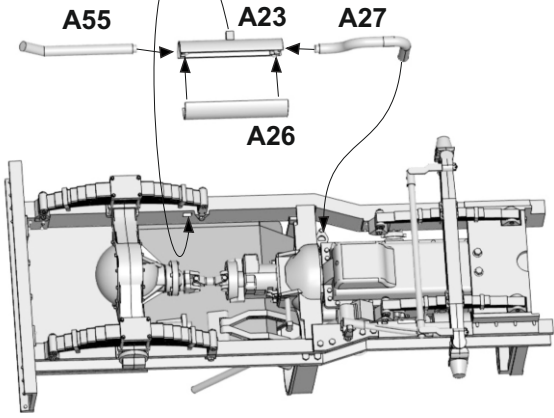
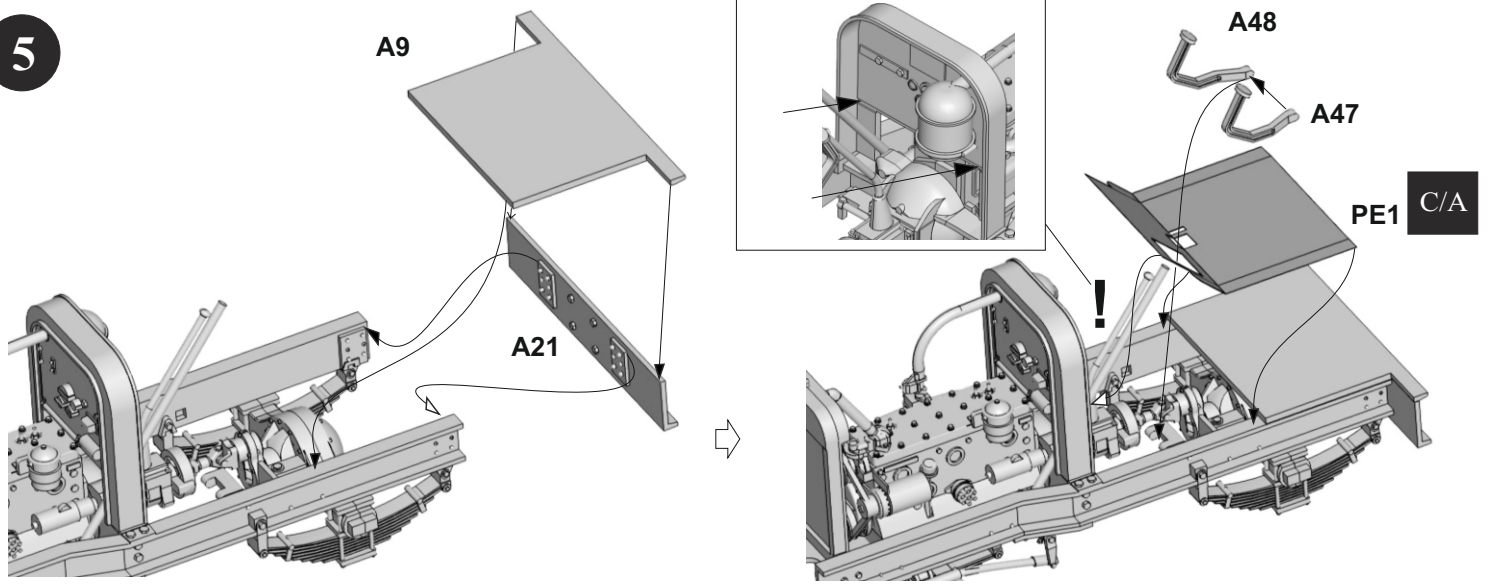

6

5

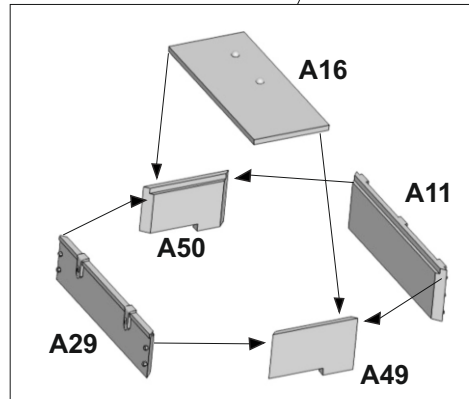

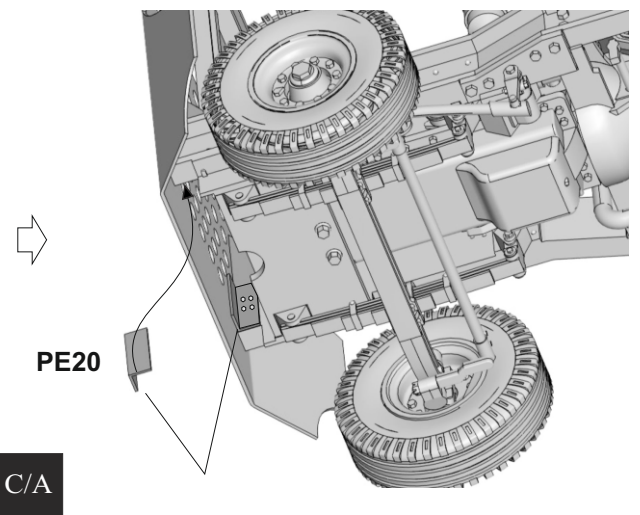
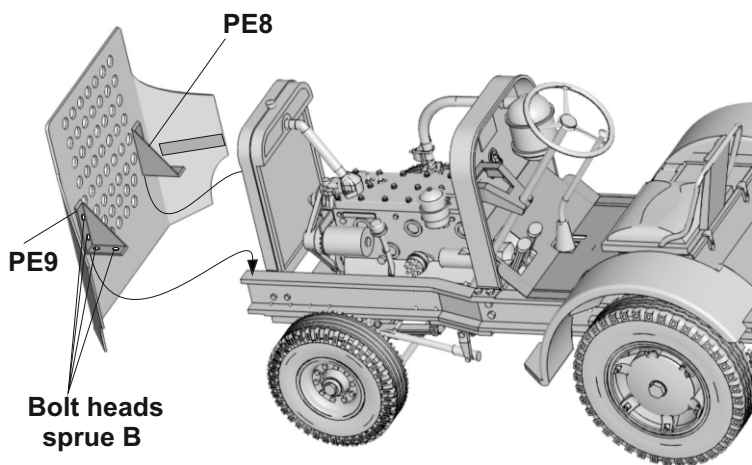
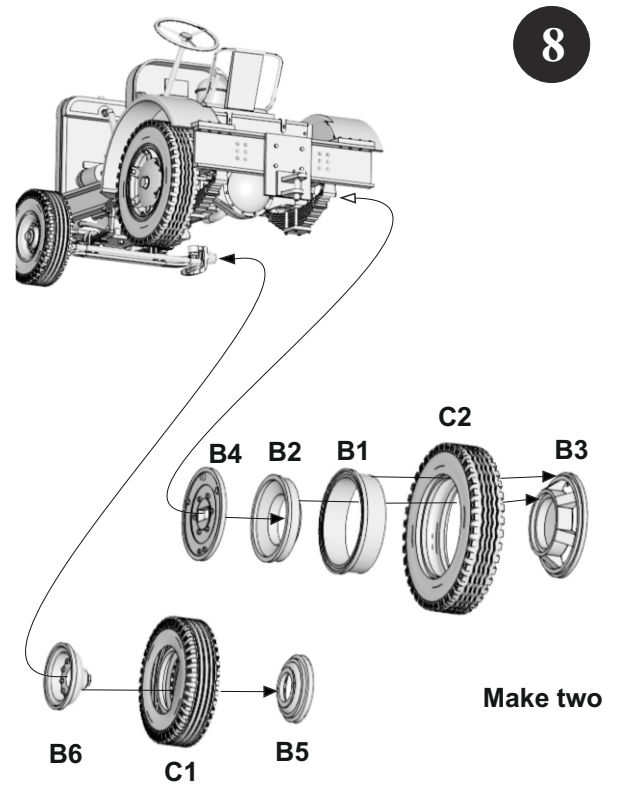
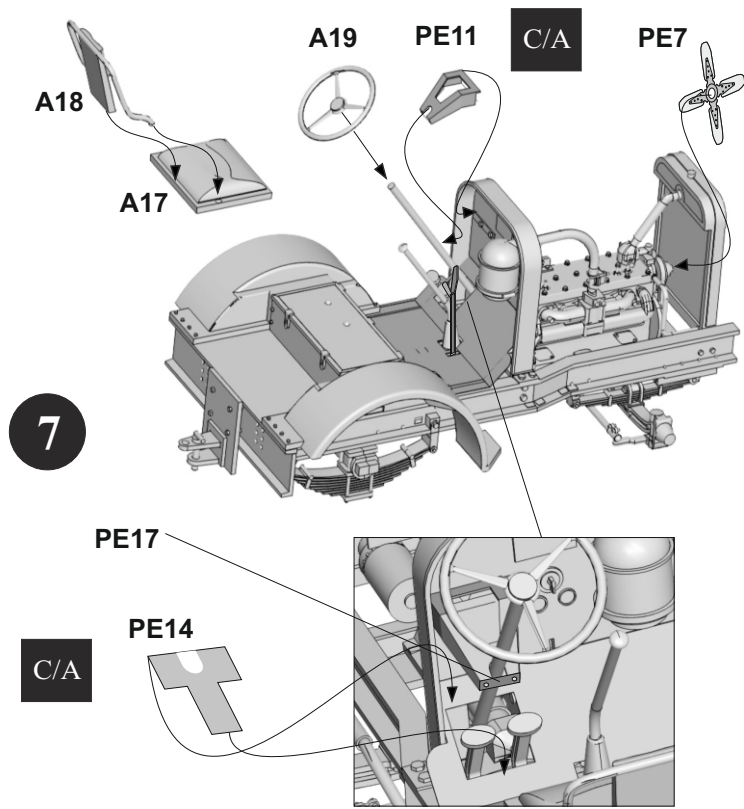

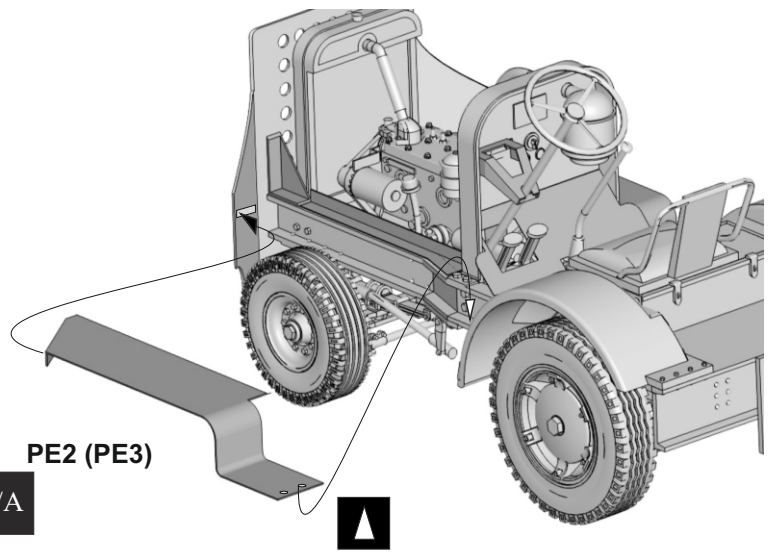
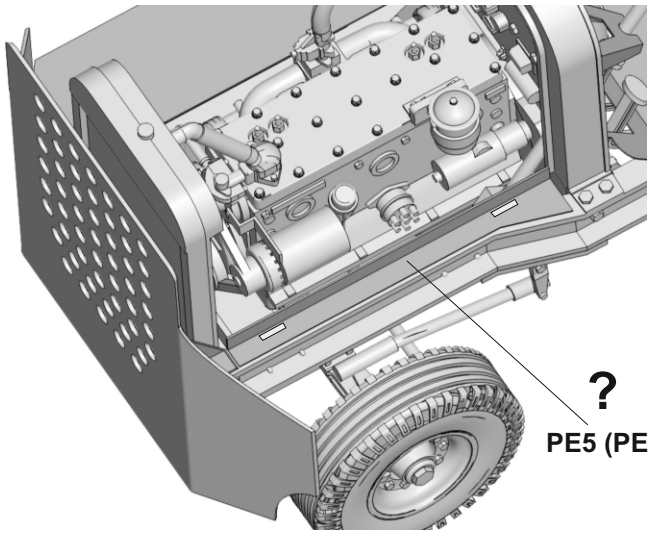

C/A

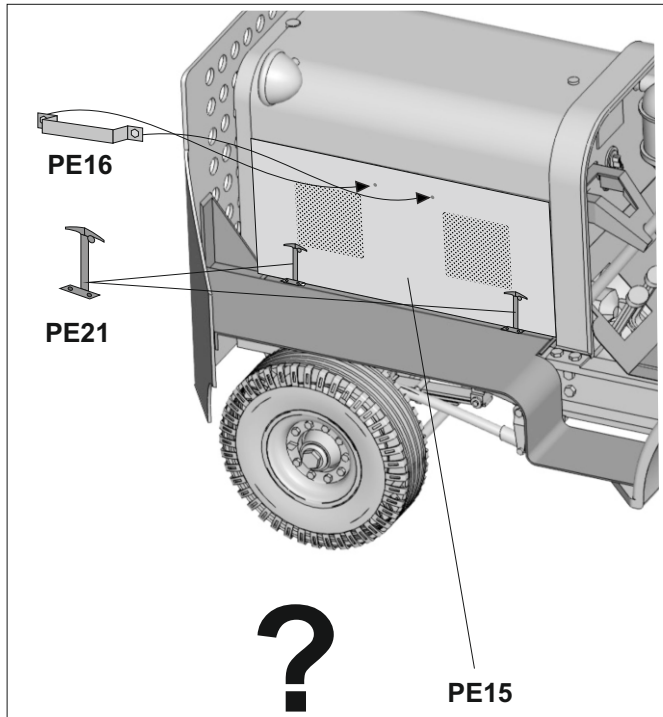
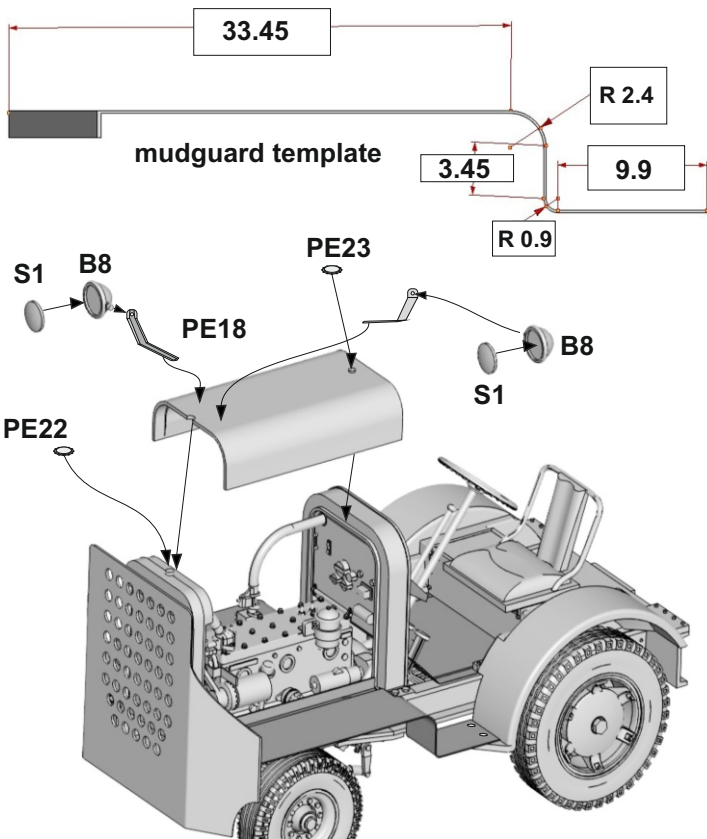

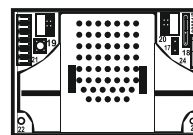
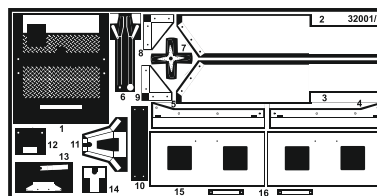
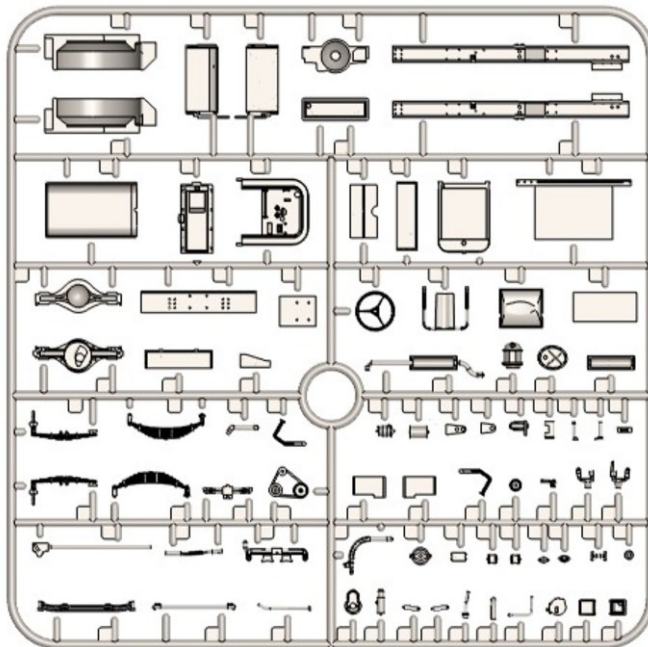
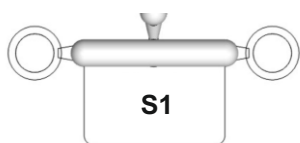
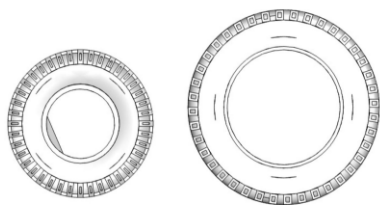
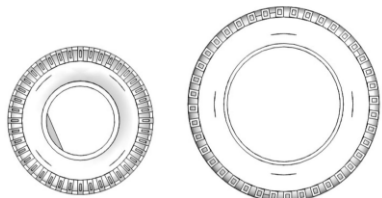
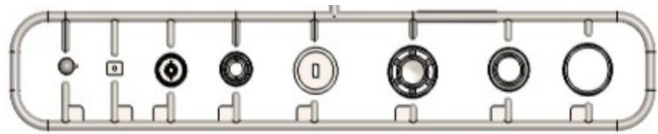
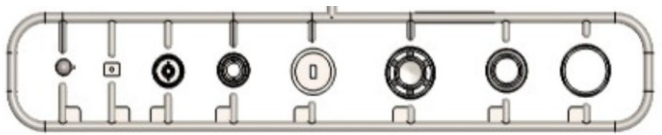

Hi-Res PDF Instructions available to download at:
<https://www.thundermodel.com/Instructions--building-tips.html>