

United



DC 10 Friend Ship



United Stars & Bars
Douglas DC-10-10
for the 1/144 Scale
Revell DC-10 Kit

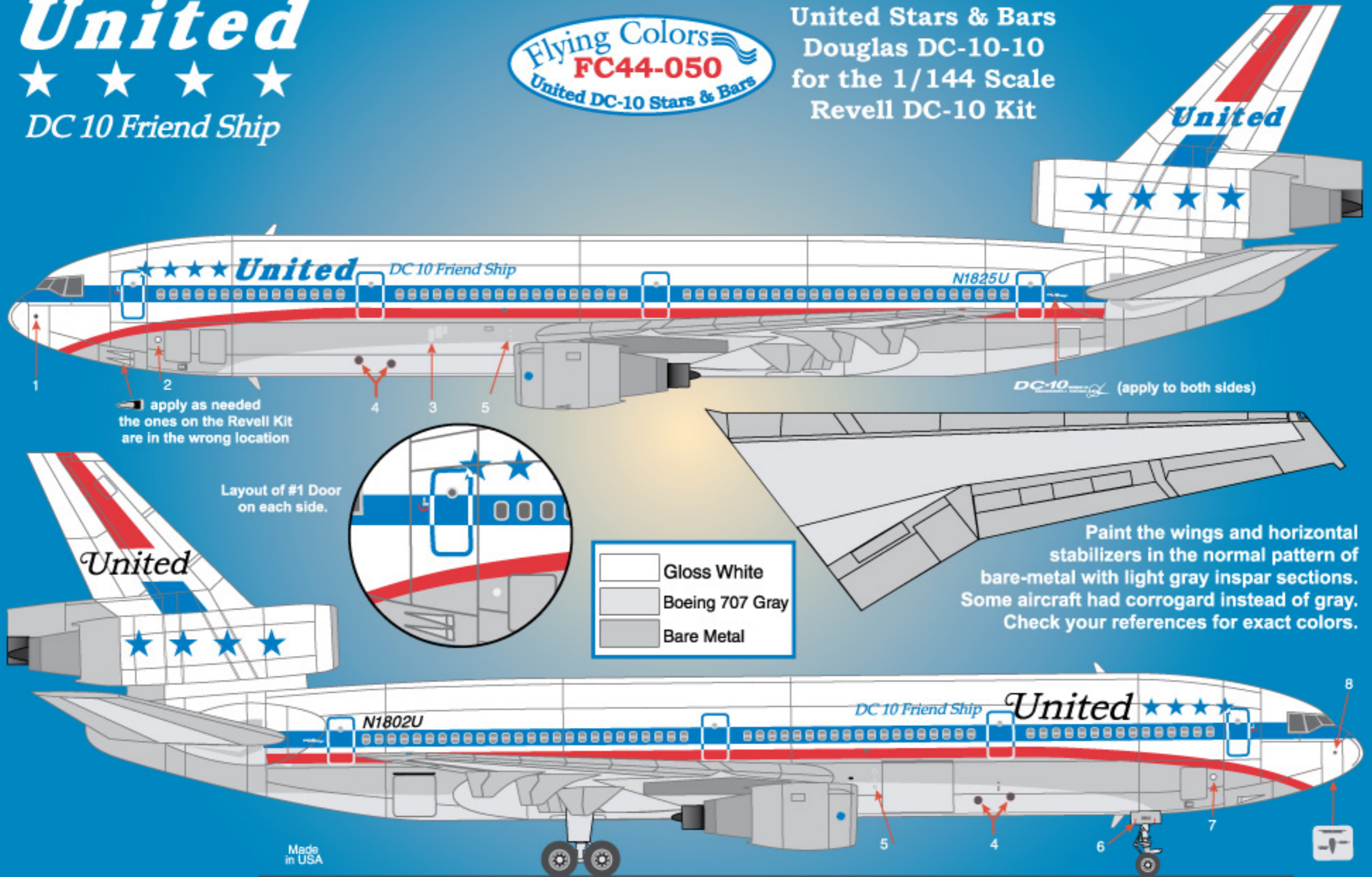

Finally a reason to use those old striker plates provided in the Revell Kit. United's Stars & Bars scheme was actually the second scheme to be worn on the DC-10 from about 1972 to 1976. Perhaps the most attractive scheme to ever adorn United's DC-10s, the scheme was finally replaced by the 3-stripe scheme.

Paint the upper fuselage gloss white. Use a copy of the decal sheet to help in masking for the bare-metal belly. The red is opaque so a tight mask may not be necessary in the first place. However, notice how it sweeps up towards the tail and actually runs through the #2 engine cowlings and pylon. During this scheme the aircraft were still pretty new so the wings and horizontal stabilizers had the light gray inspar sections, but there were a few exceptions. Paint those as shown. Also, notice the light gray areas before and aft of the wing-root fairing.

Apply the decals as shown on the drawings. You have a choice of either black or blue titles. The blue titles and registration numbers actually came after the black titles. Enough numbers are provided to model any aircraft in the fleet at the time. Registrations ran consecutively from N1801U to N1838U for this scheme and all were series 10 airplanes. Fleet numbers on the nose-wheel doors were comprised of a "38" followed by the last two digits of the registration number. For example N1802U becomes 3802.

A great site on the web for reference photos is www.airliners.net. You should be able to find plenty of pictures of this great scheme to help in the modeling process. For the latest news and info on the whole line of Flying Colors Decals, be sure to visit www.flyingcolorsdecals.com.

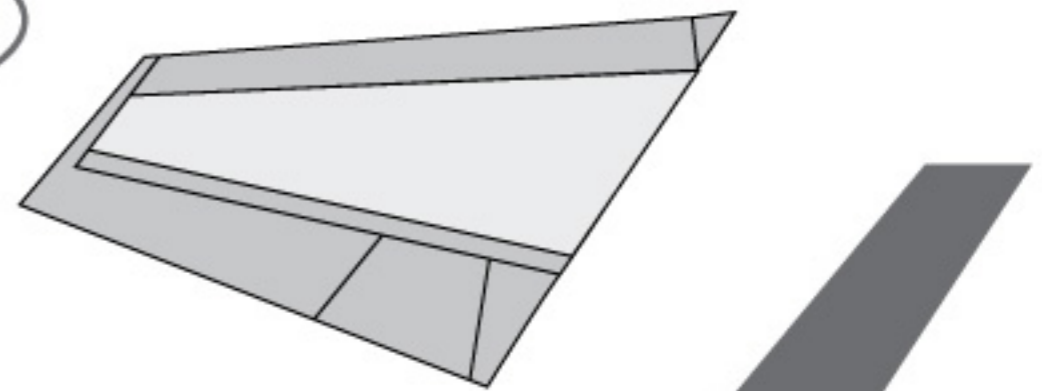

United



DC 10 Friend Ship