

Fw 190A-4

eduard

GERMAN WWII FIGHTER

1/48 SCALE PLASTIC KIT

ProfiPACK
edition

#82142



INTRO

The second half of the Second World War saw the Focke-Wulf Fw 190, in its various forms, emerge as the best of what was available to the Luftwaffe. The dedicated fighter version was a high performance, heavily armed machine. Its development had a precarious beginning, against a 1938 specification issued by the Technisches Amt, RLM. The first prototype took to the air on June 1st, 1939. After a series of improvements and even radical changes, the design culminated in the fall of 1940 in the pre-series version Fw 190A-0 to the tune of twenty-eight pieces. Six of these were retained by the test unit Erprobungsstaffel 190 at Rechlin, which was tasked with conducting service trials. These revealed a wide range of flaws to the point where the RLM halted further development. Despite this, on the basis of urgings from the test unit staff, the aircraft was not shelved. After a series of some fifty modifications, the RLM gave the go ahead for the Fw 190 to be taken into inventory of the Luftwaffe. In June 1941 the Luftwaffe accepted the first of 100 ordered Fw 190A-1s, armed with four 7.9 mm MG 17s. By September 1941 II./JG 26 was completely equipped with the type operating on the Western Front. November saw the production of the next version Fw190A-2, powered by a BMW 801C-2, and armed with two 7.9 mm MG 17s and two MG 151s of 20 mm caliber in the wings. Part of this series received an additional pair of 20 mm MG FFs, thus attaining an armament standard of later types. A significant advancement to the design came in the spring 1942, when the BMW 801D-2 became available, whose installation gave birth to the Fw 190A-3. July saw the development of the improved A-4. Both were armed with what became the standard two fuselage mounted MG 17s, two wing mounted MG 151 cannons, and two MG FF cannons, placed inboard of the wheel wells. During 1942 production had intensified, and a production facility was set up under license at Fieseler. Thanks in part to this, production rose in 1942 to 1,878 units as opposed to 224 in 1941. Large-scale production of the A-5 was initiated in April 1943 with an identical wing to the A-4, but with a nose extension that would become standard on all subsequent Fw 190A versions up to the A-9, and also on the corresponding F types. July saw the development of a new, strengthened wing, which incorporated MG 151s instead of the MG FFs in the outer position. The adoption of this wing developed the A-6 version. Further changes developed the A-7, produced during the end of 1943. This version came about with the replacement of the fuselage mounted MG 17s with 13 mm MG 131s. Further improvements led to the Fw 190A-8, and this version became the most widely produced with some 1400 units made. The most significant change to this variant was the installation of the GM-1 nitrous-oxide injection system, for temporary power boost in combat. A portion of A-8 production was built as the A-8/R2 and A-8/R8, armed with MK 108 cannon in the outer wing location, and with armoured slabs added to the cockpit sides and a modified canopy. The final production version of the BMW 801 powered fighter was the Fw 190A-9, equipped with the BMW 801TS of 2000 hp (1470 kW). There was a parallel development of these fighter optimized aircraft with a dedicated fighter-bomber version, the Fw 190F. These aircraft had reduced wing armament to two MG 151 cannons in the wing root position. The engine was optimized for low level operation, and the armament options varied to satisfy the ground attack role, including bombs of various weight classes and a variety of anti-tank rockets. This branched into the extended range Fw 190G version. Development of the throughbred fighter continued in the guise of the Fw 190D, which began to reach Luftwaffe units in the second half of 1944, and was the result of mounting an in-line Jumo 213A-1 engine into a modified Fw 190A-8 airframe. Although the Fw 190 never achieved the widespread usage of the competing Bf 109, its contribution to the German Air Force was certainly significant through the second half of WWII. Fw 190s saw service on the Western Front as well as in the East. As heavy fighters with imposing firepower, they found themselves integral components, from 1943 onwards, within the units tasked with the protection of the Reich from the ominous clouds of allied four-engined bombers. This is where the A-8 version was instrumental, along with its A-8/R2 armoured development. This version, with its firepower, was a very ominous and daunting foe for the bomber crews. From the second half of 1944, their danger was kept in check to a degree by escorting P-47s, and necessitated the development of the P-51 Mustang.

ATTENTION



UPOZORNĚNÍ



ACHTUNG



ATTENTION



注意



Carefully read instruction sheet before assembling. When you use glue or paint, do not use near open flame and use in well ventilated room. Keep out of reach of small children. Children must not be allowed to suck any part, or pull vinyl bag over the head.



Před započítím stavby si pečlivě prostudujte stavební návod. Při používání barev a lepidel pracujte v dobře větrané místnosti. Lepidla ani barvy nepoužívejte v blízkosti otevřeného ohně. Model není určen malým dětem, mohlo by dojít k požití drobných dílů.

INSTRUCTION SIGNS * INSTR. SYMBOL * INSTRUKTION SINNBILDEN * SYMBOLES * 記号の説明

OPTIONAL
VOLBABEND
OHNOUTOPEN HOLE
VYVRTAT OTVORSYMETRICAL ASSEMBLY
SYMETRICKÁ MONTÁŽREMOVE
ODŘÍZNOUTREVERSE SIDE
OTOČITAPPLY EDUARD MASK
AND PAINT
POUŽIT EDUARD MASK
NABARVIT

PARTS



DÍLY



TEILE



PIÈCES



部品

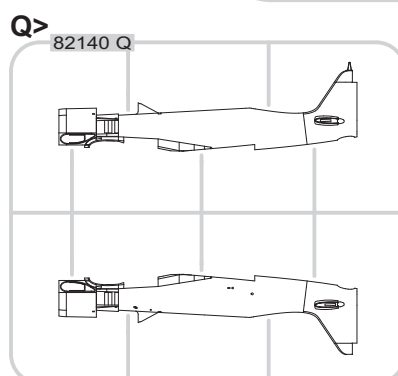
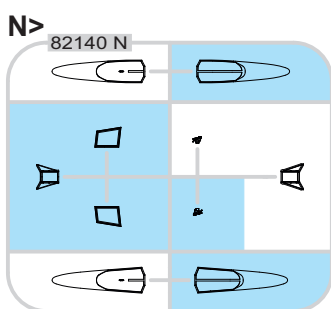
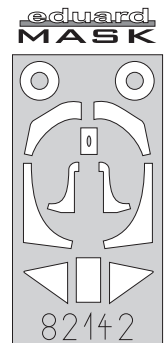
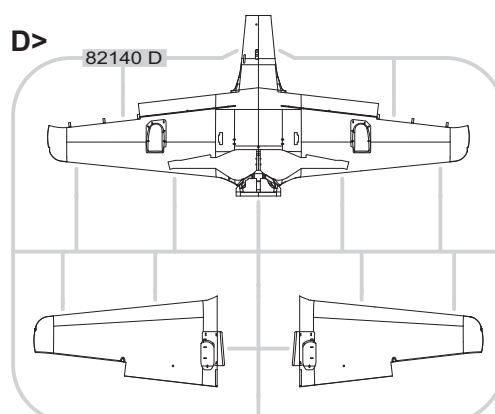
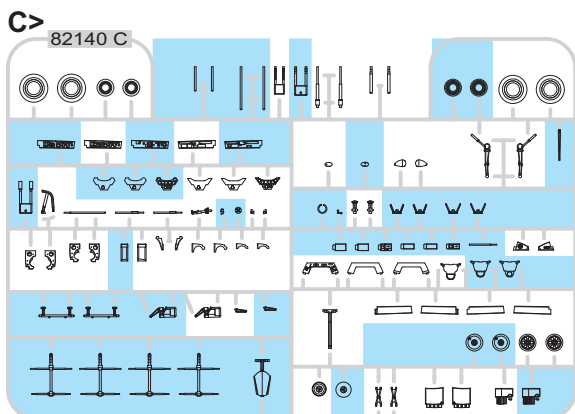
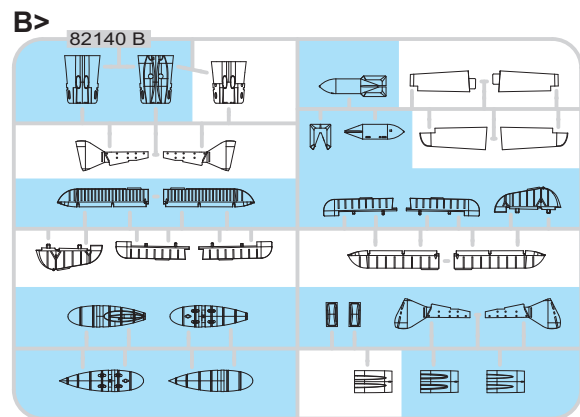
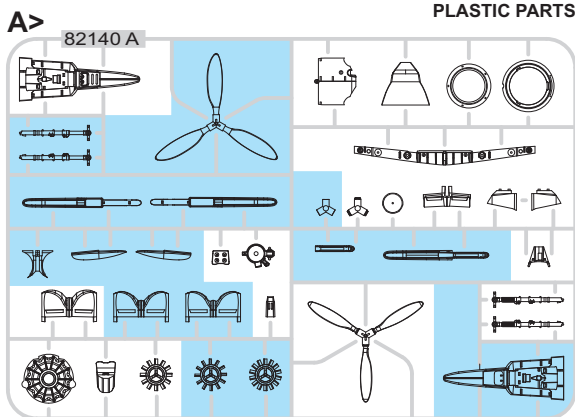

PE - PHOTO ETCHED DETAIL PARTS

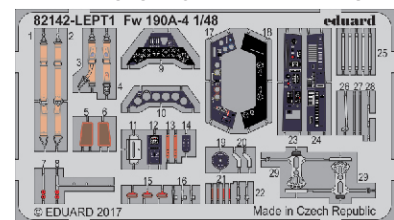

-Parts not for use. -Teile werden nicht verwendet. -Pièces à ne pas utiliser. -Tyto díly nepoužívejte při stavbě. - 使用しない部品

COLOURS



BARVY



FARBEN



PEINTURE



色

GSi Creos (GUNZE)		
AQUEOUS	Mr.COLOR	
H1	C1	WHITE
H2	C2	BLACK
H11	C62	FLAT WHITE
H12	C33	FLAT BLACK
H33	C81	RUSSET
H47	C41	RED BROWN
H65	C18	RLM70 BLACK GREEN
H66	C119	RLM79 SANDY BROWN
H68	C36	RLM74 DARK GRAY
H69	C37	RLM75 GRAY
H70	C60	RLM02 GRAY
H77	C137	TIRE BLACK

AQUEOUS	Mr.COLOR	
H90	C47	CLEAR RED
H94	C138	CLEAR GREEN
H310	C310	BROWN
H312	C312	GREEN
H413	C113	RLM04 YELLOW
H414	C114	RLM23 RED
H416	C116	RLM66 BLACK GRAY
H417	C117	RLM76 LIGHT BLUE
Mr.METAL COLOR		
	MC213	STEEL
	MC214	DARK IRON
Mr.COLOR SUPER METALLIC		
	SM06	CHROME SILVER

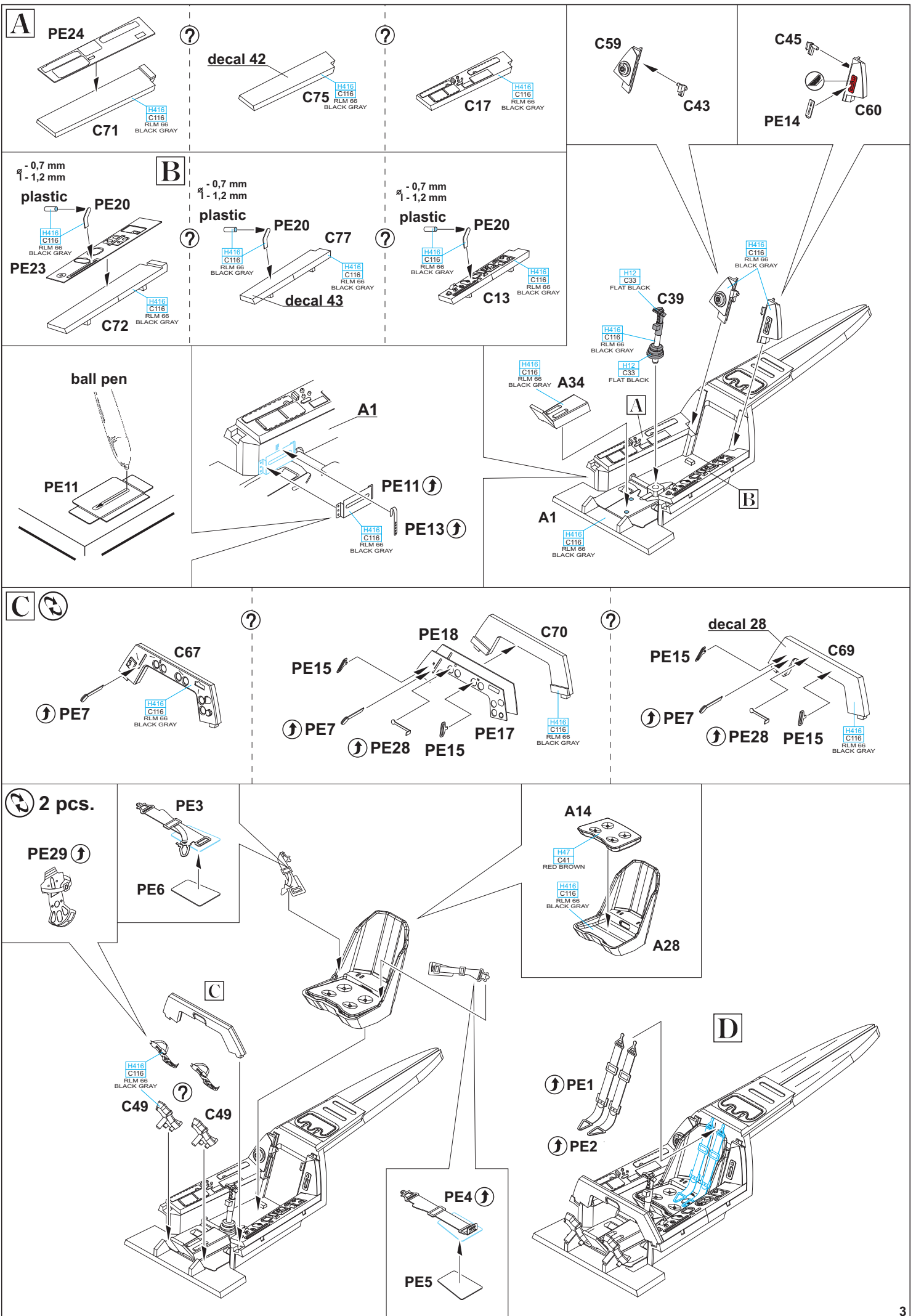

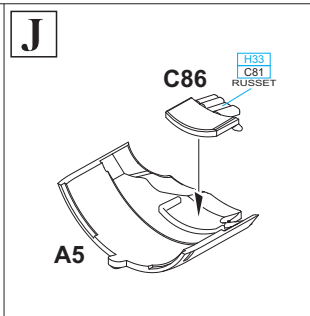
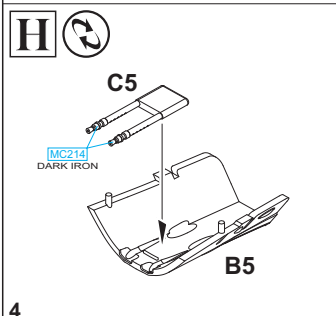
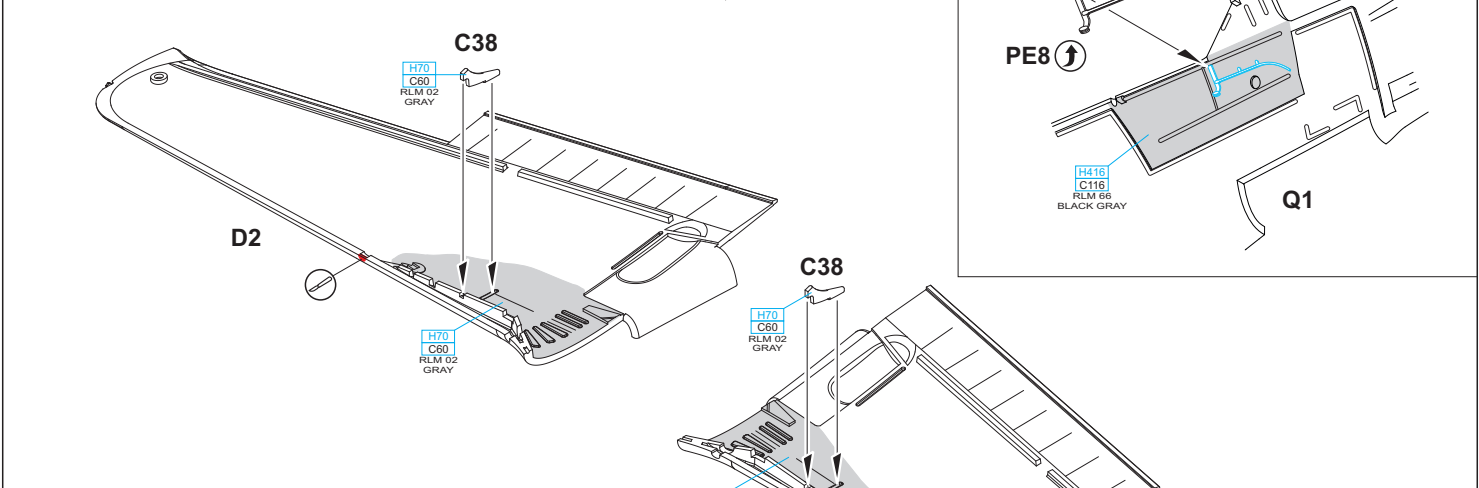
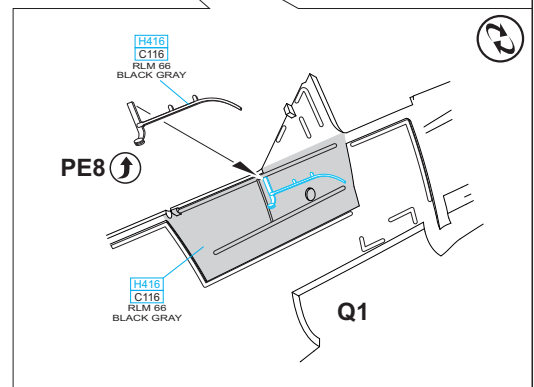
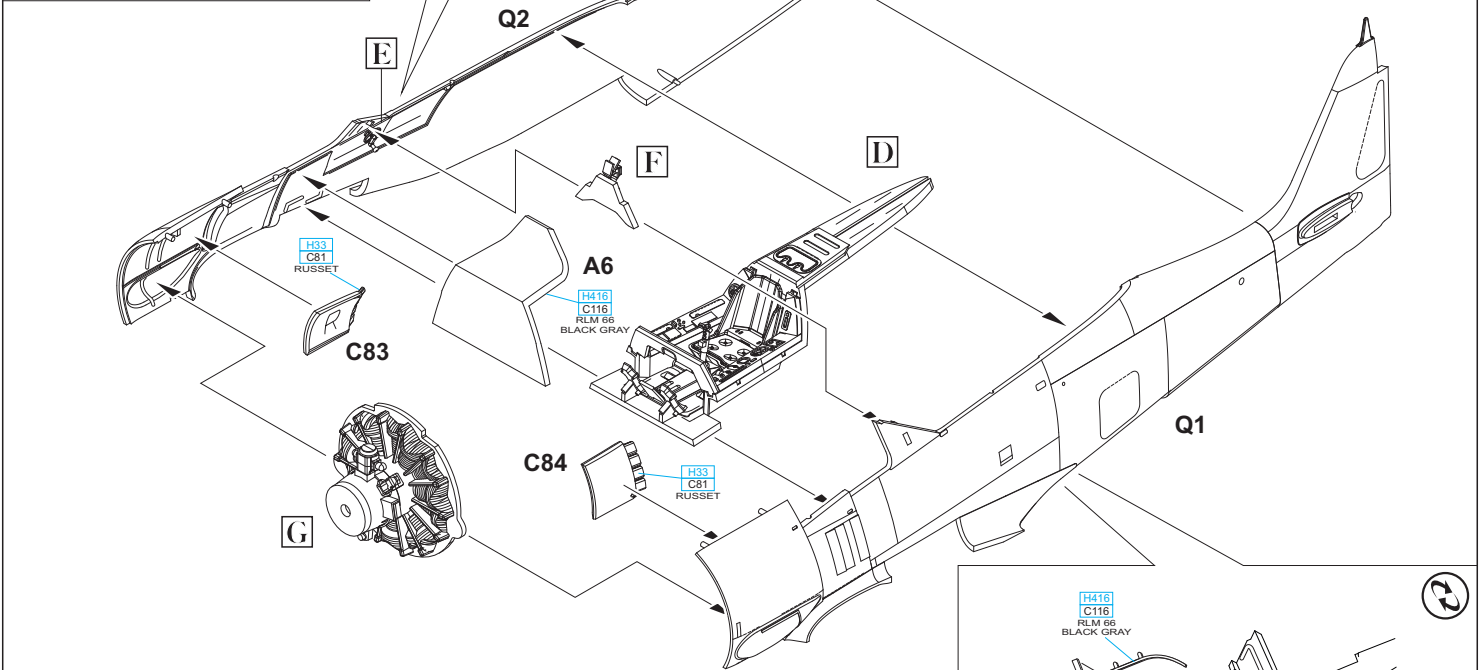
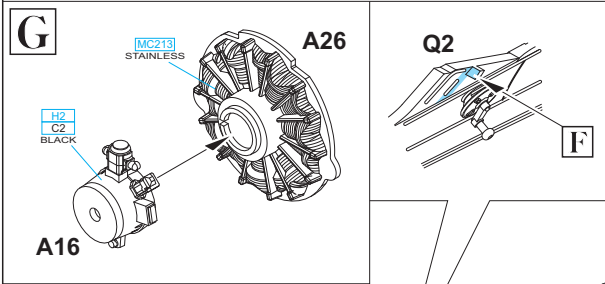
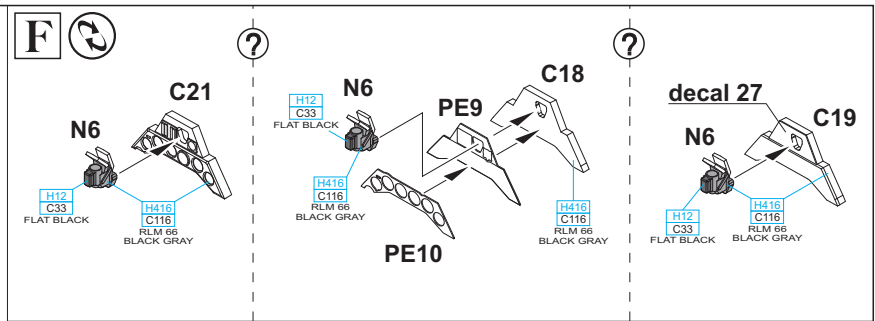
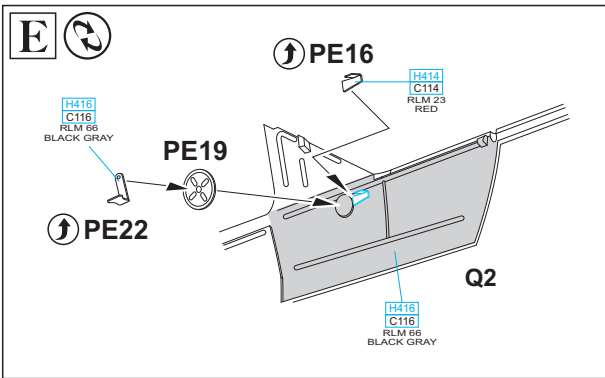

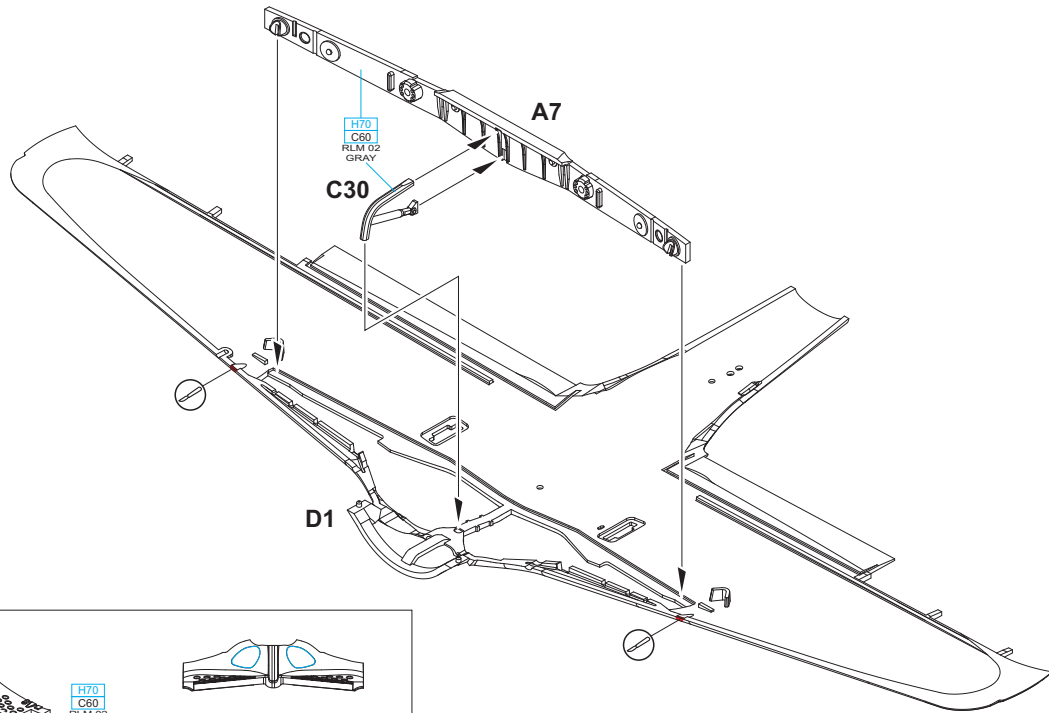

K

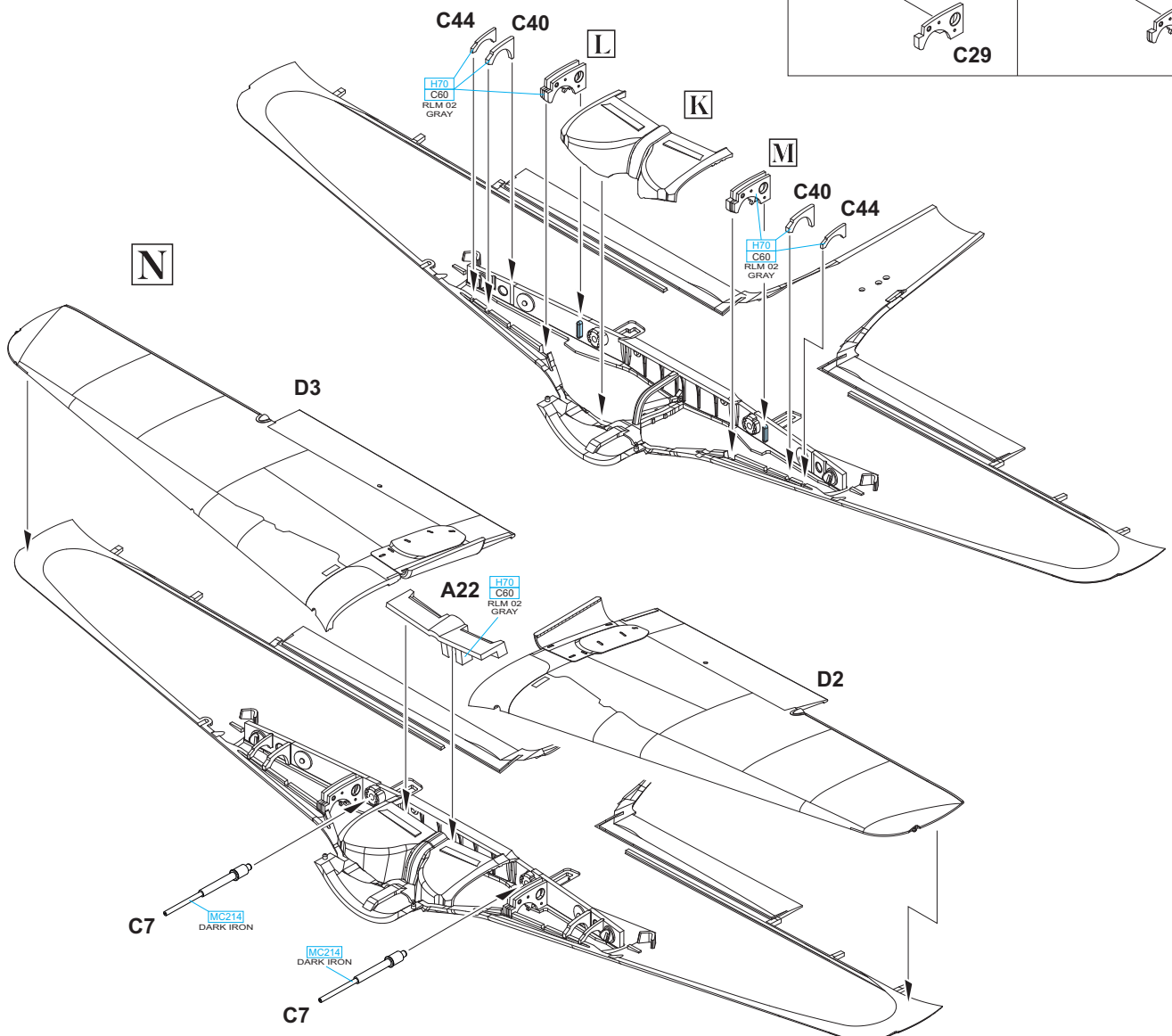
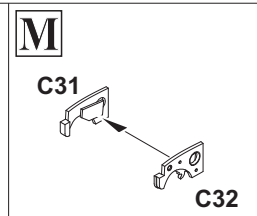
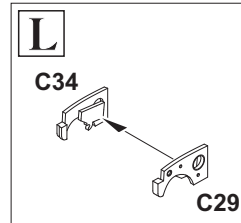
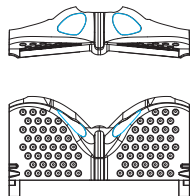
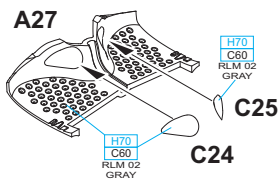

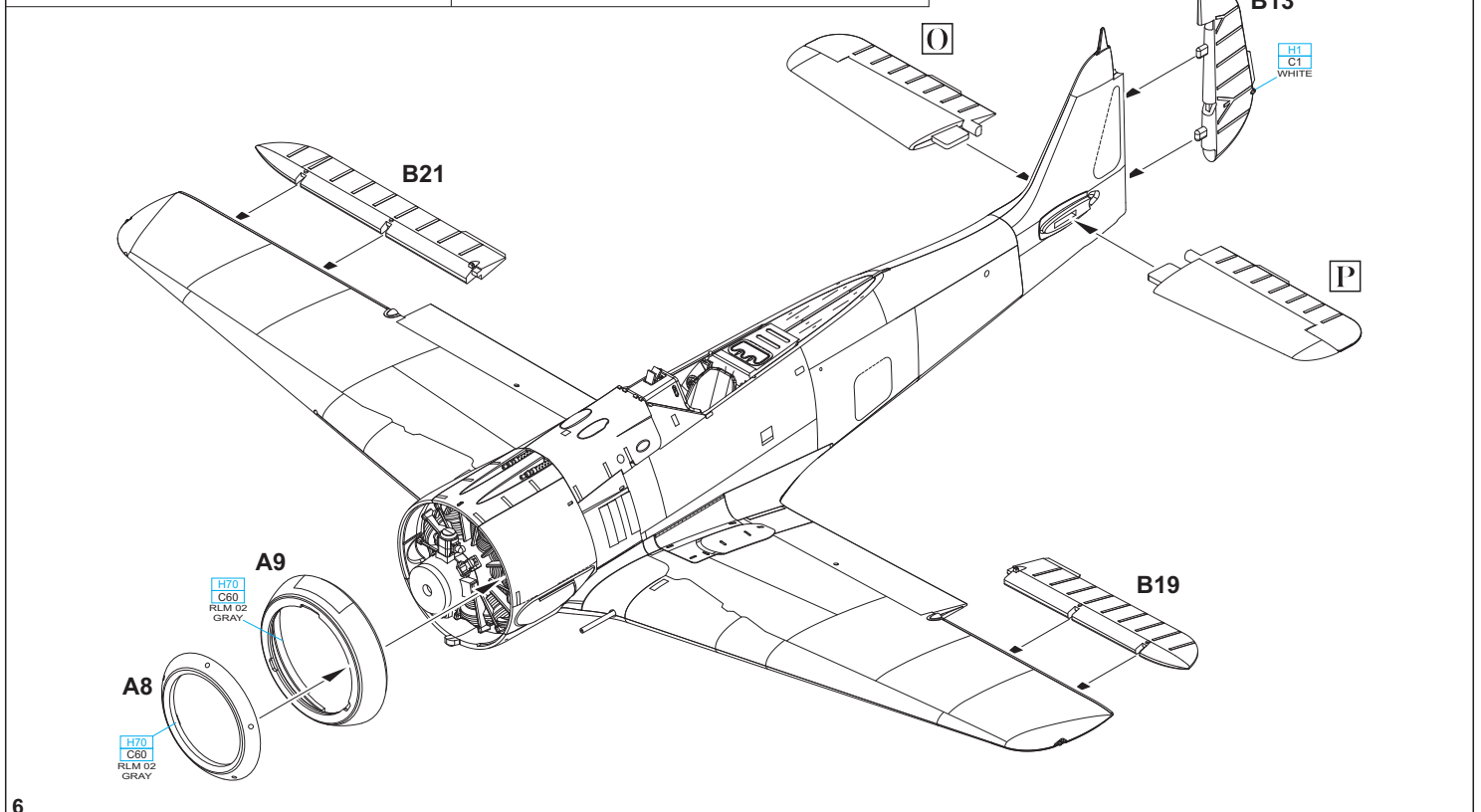
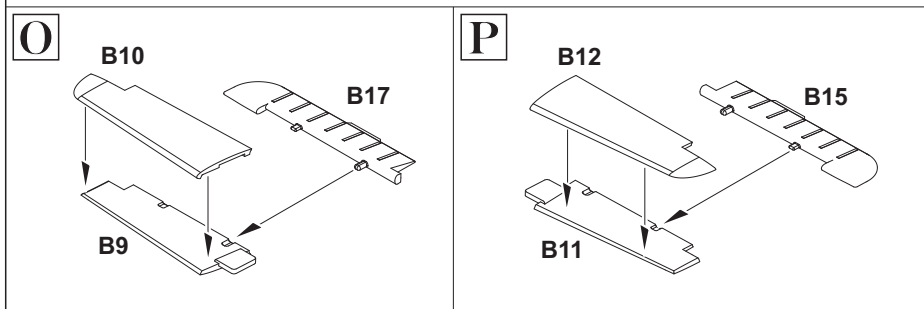
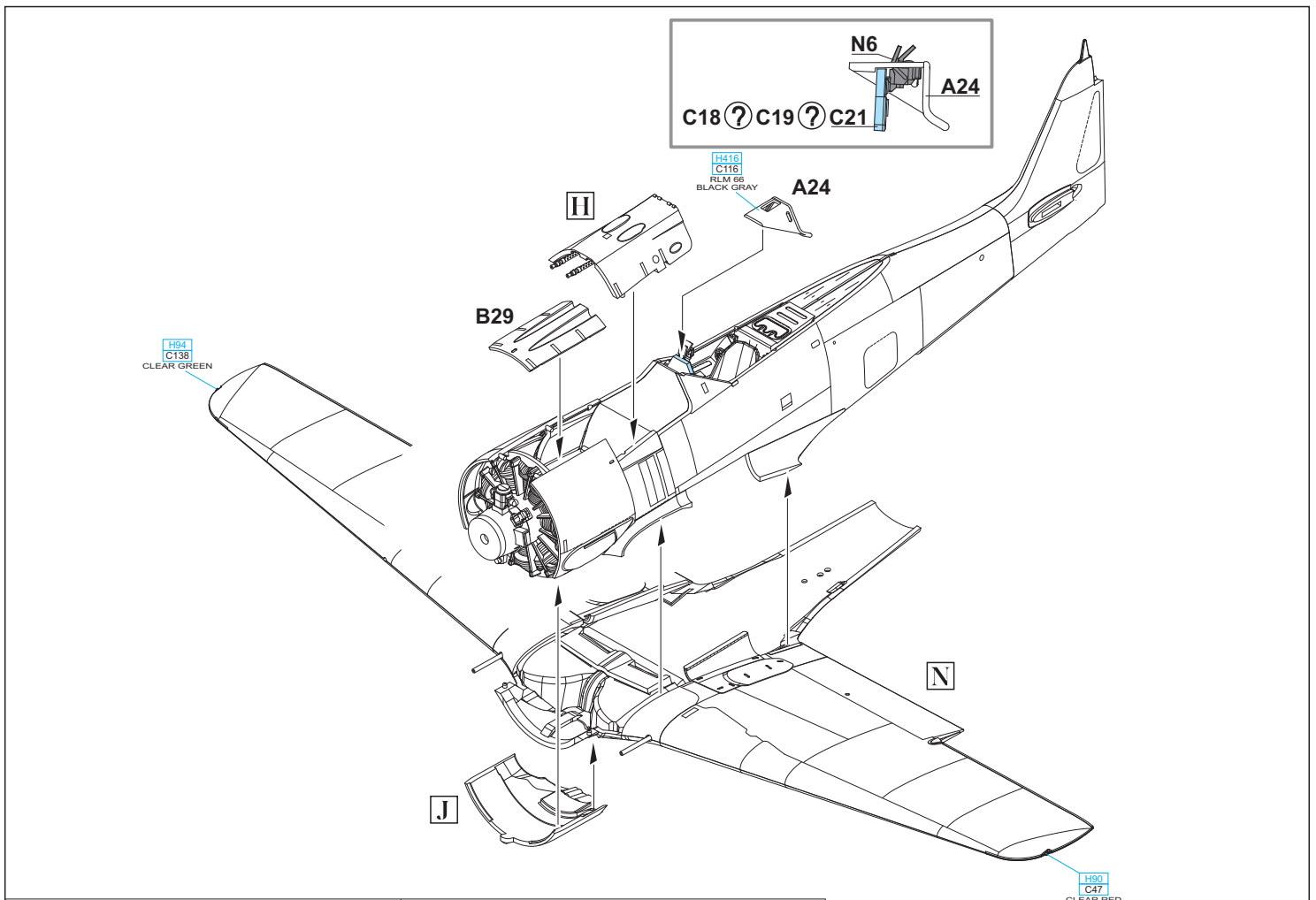

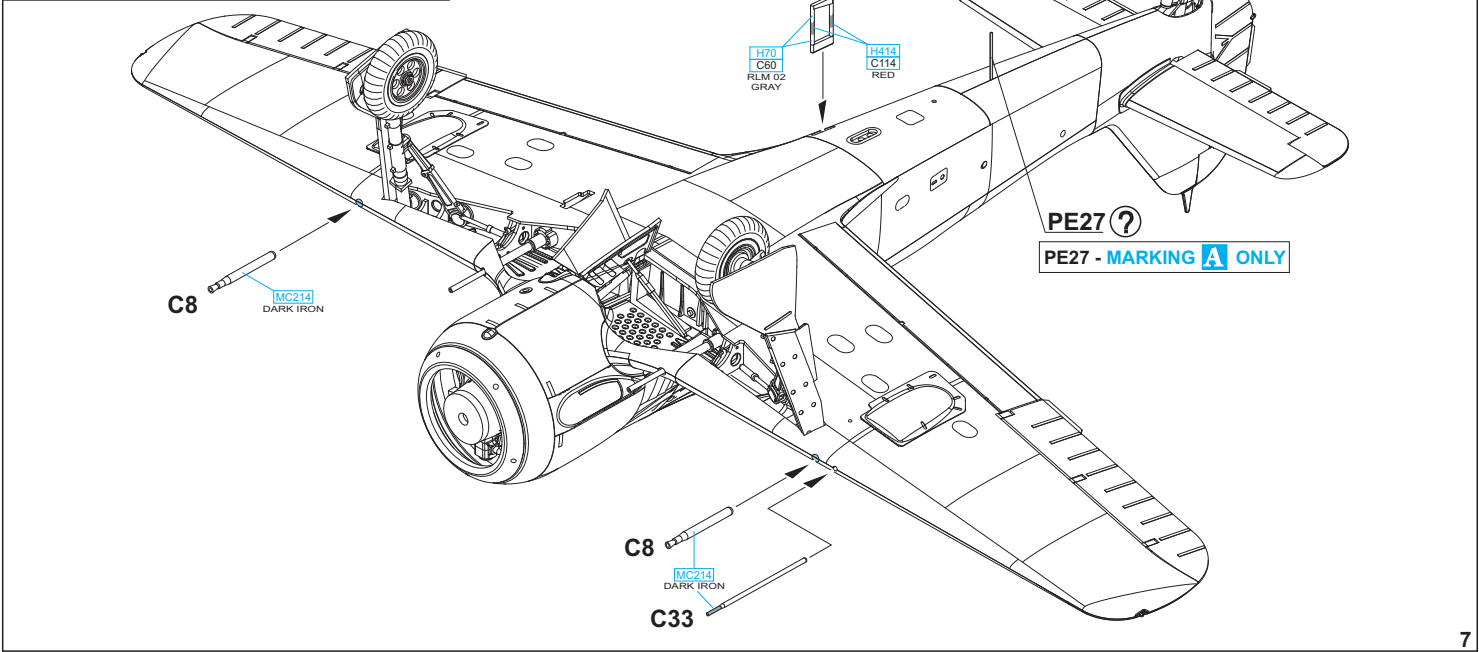
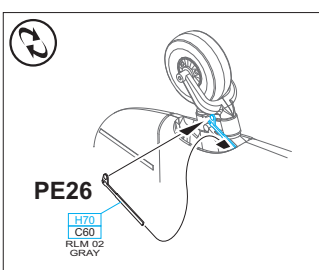
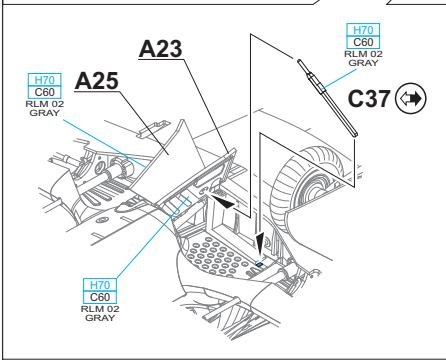
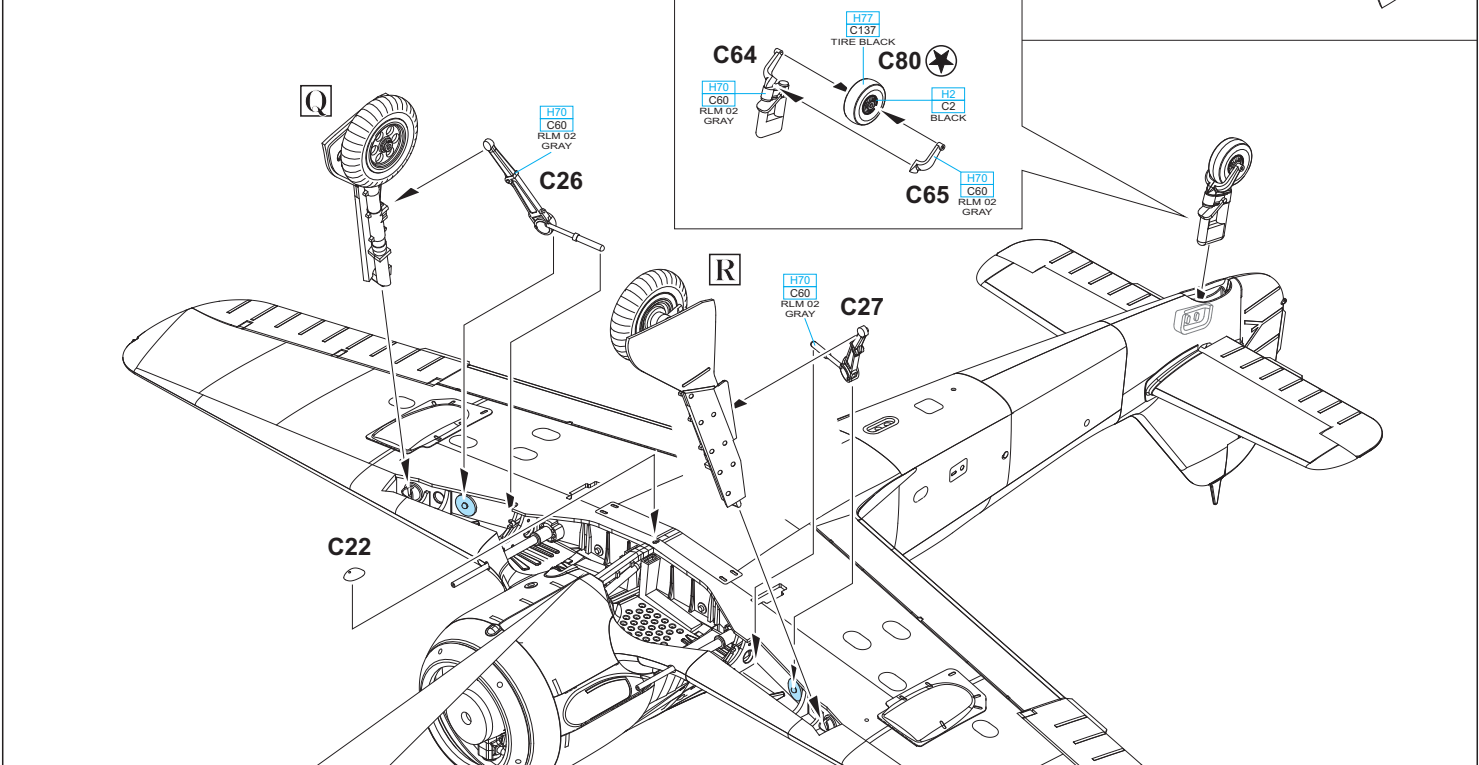
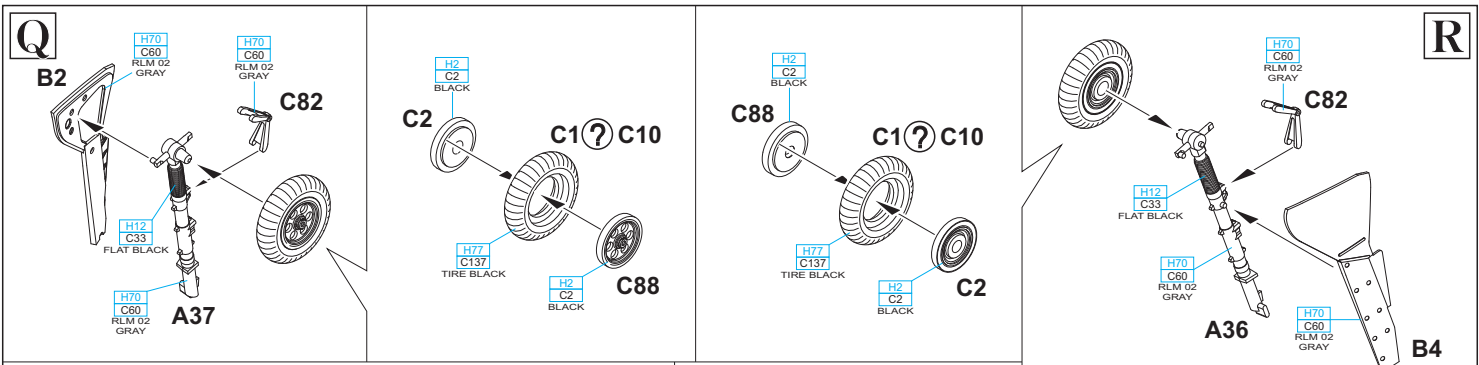

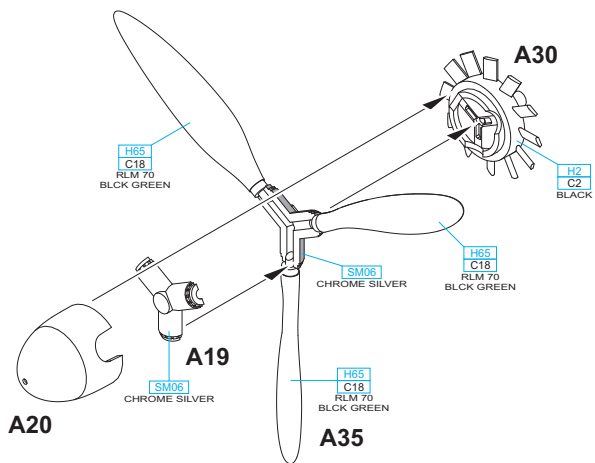
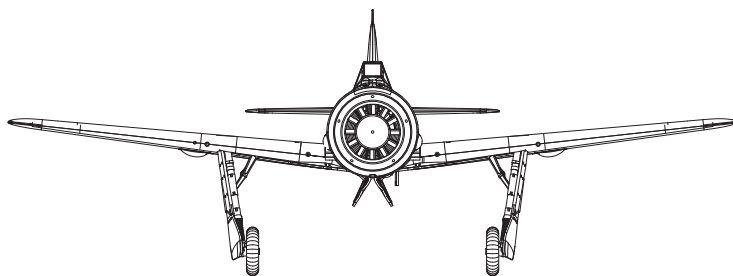
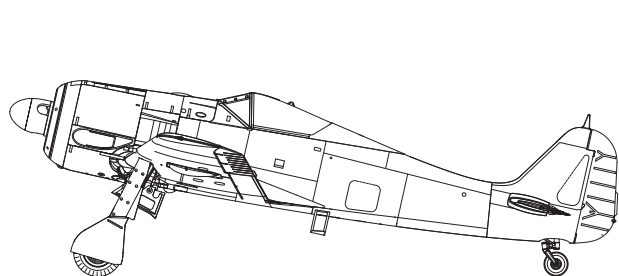
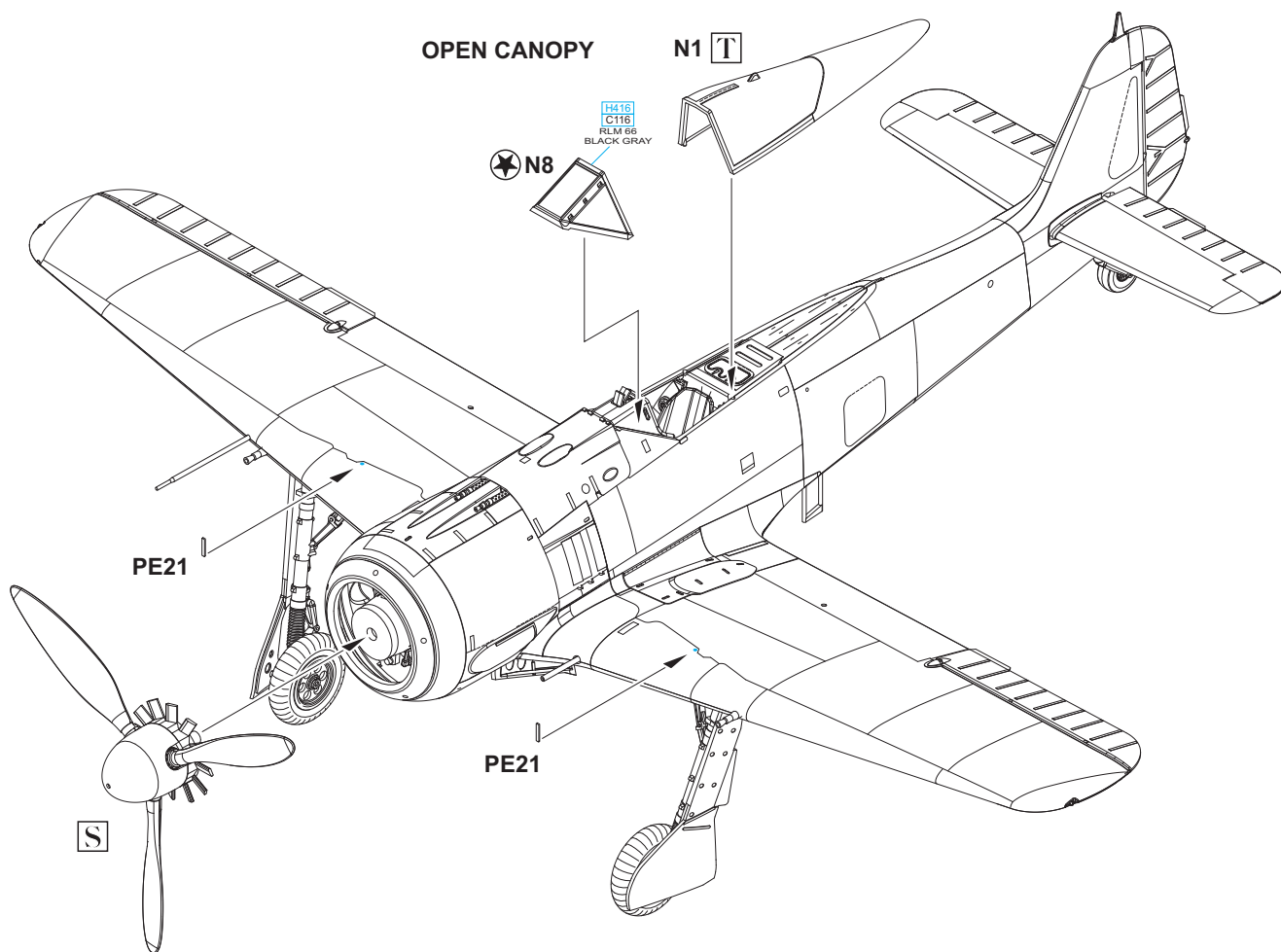
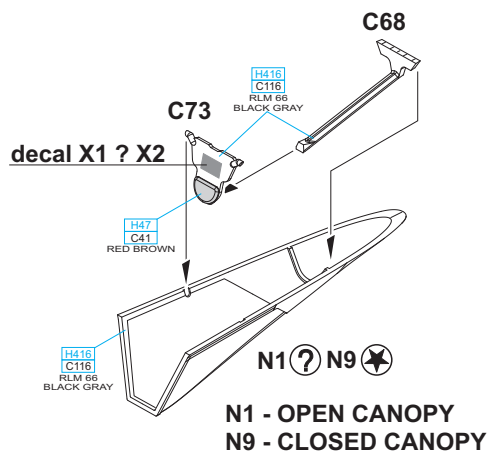
S**T**

CLOSED CANOPY

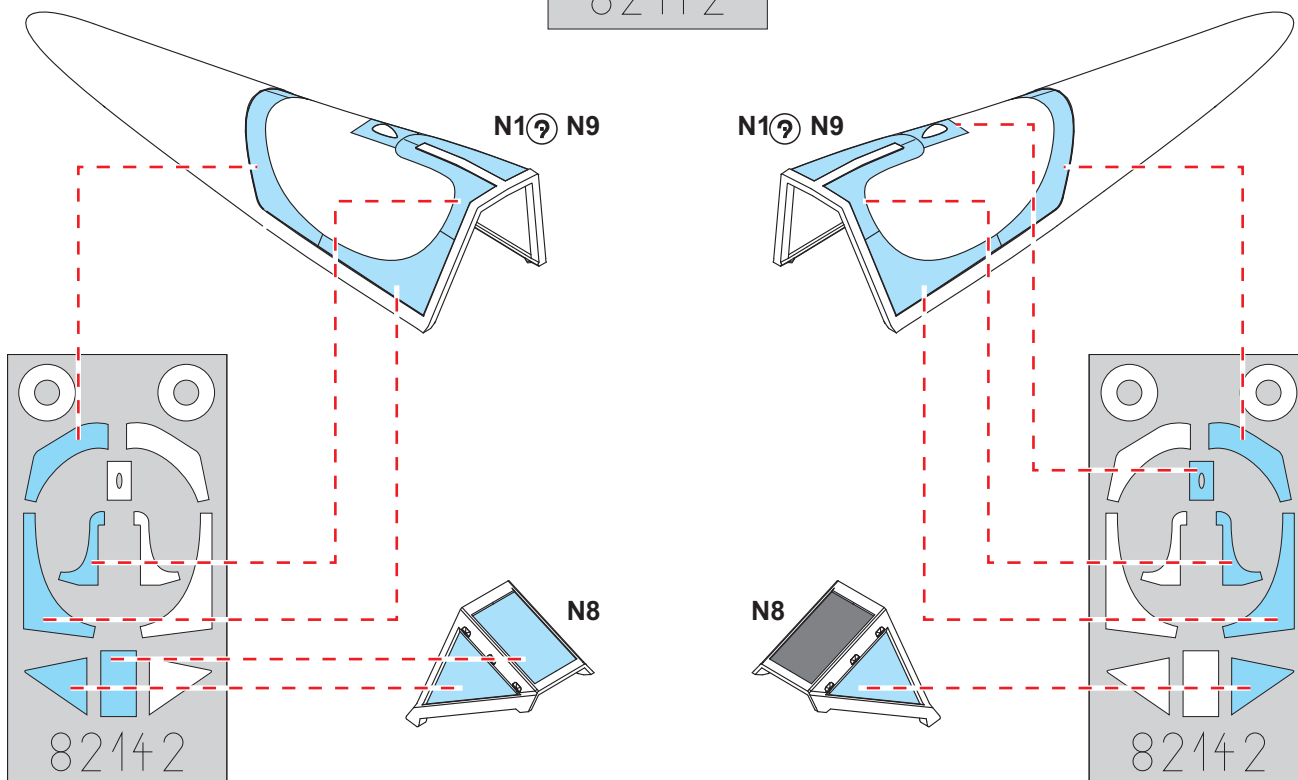
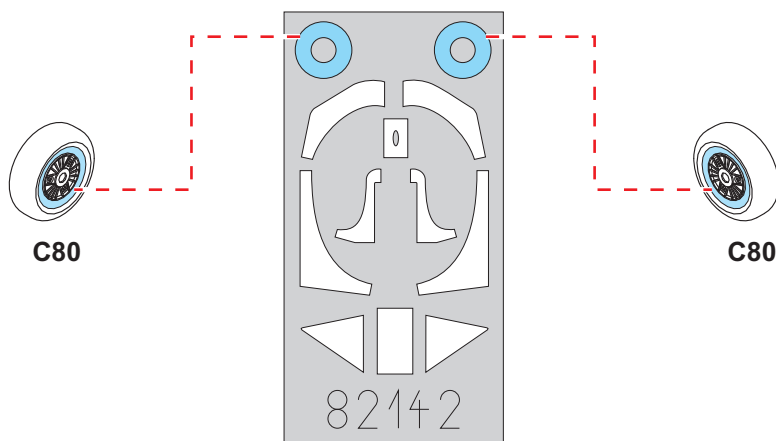
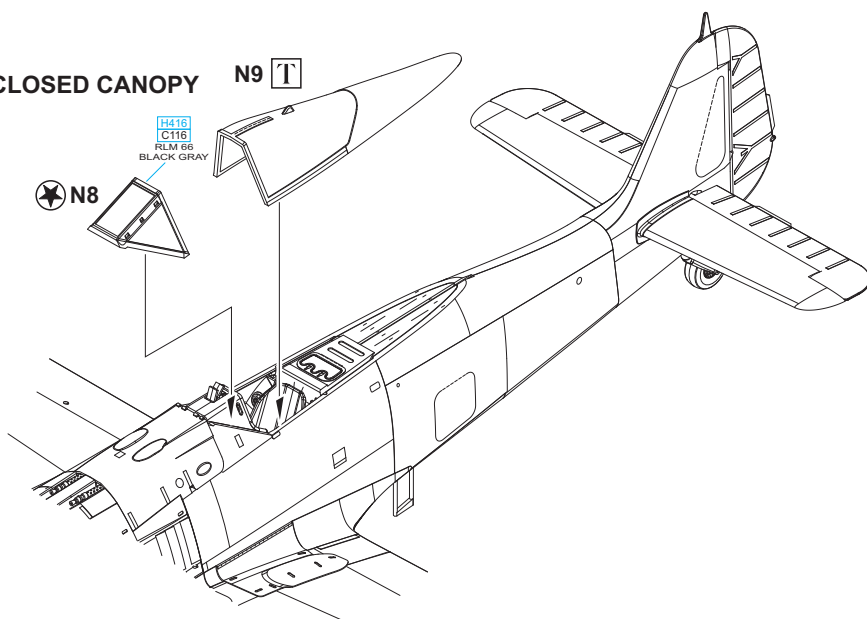

A W. Nr. 746, flown by Oblt. S. Schnell, CO of 9./JG 2, Vannes-Meucon, France, January 1943

Siegfried 'Wumm' Schnell, a native of today's Polish Sulecin (then Zielenzig in Brandenburg) joined the ranks of the Luftwaffe in 1936 and at the beginning of the Second World War he served with 4./JG 2. His first kill was in combat over France on May 14th, 1940, others followed over Britain and against English and American pilots over western Europe. After being assigned to JG 54, he first served with its III. Gruppe and was on February 1st, 1944 made CO of IV. Gruppe. While serving in this function, he was shot down on February 25th, 1944 over Narva by a Soviet fighter, this proving to be a fateful encounter. For his combat results, he was awarded on July 9th, 1941 the Knight's Cross with Oak Leaves. In Second World War downed 93 enemy aircraft. Oblt. Schnell's Fw 190A-4 wore a regular camo scheme for Luftwaffe fighters, painted with RLM 74/75/76 colours. Wings and fuselage have fresh overpainting of former white strips - identification of aircraft attending the Case Anton late 1942 (occupation of the „free zone“ Vichy France). The rudder was marked symbols of 76 victories. The fuselage around and behind exhausts is painted in black Adlerflügel, with white outline.

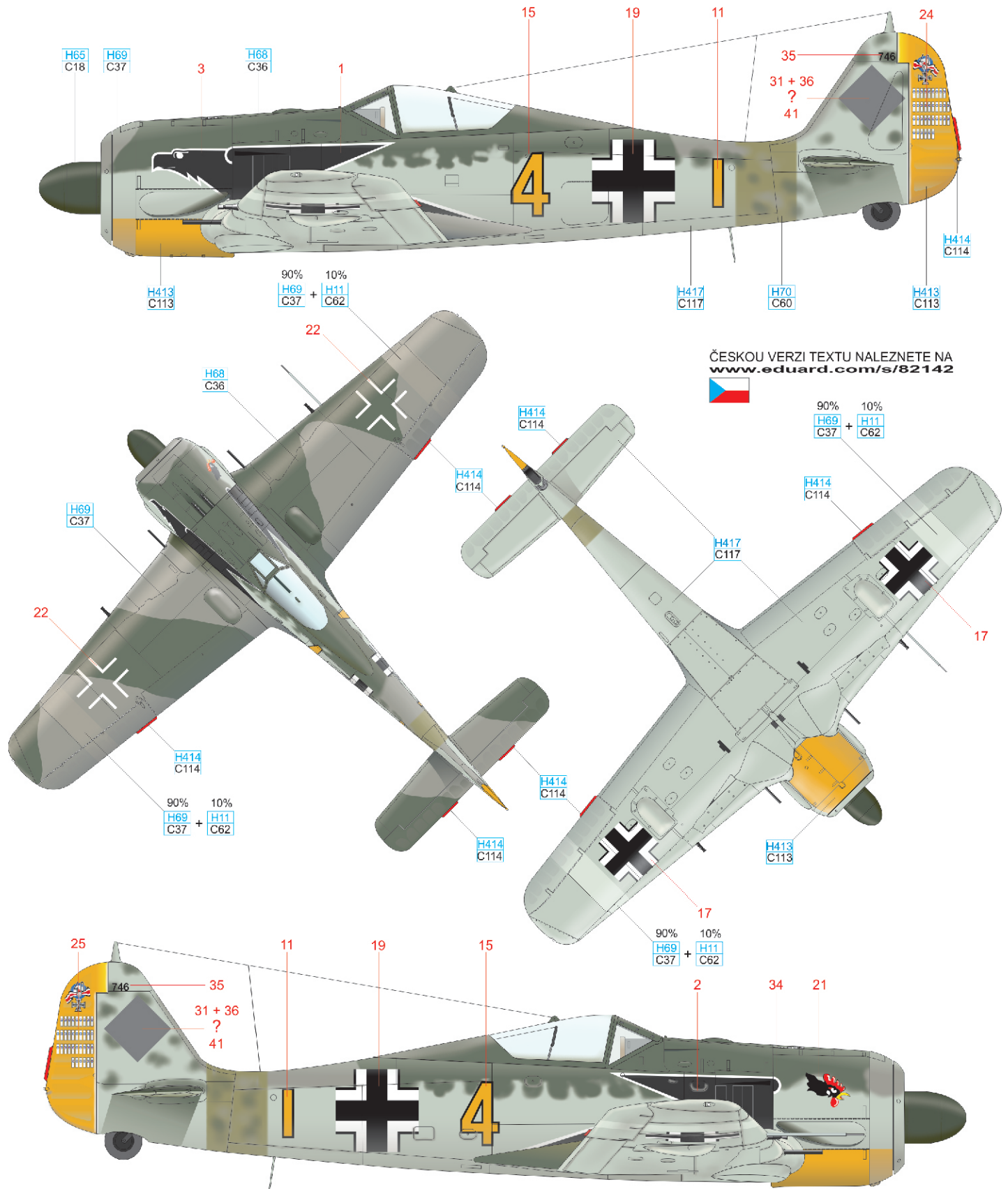

RLM 04	H413 C113	RLM 23	H414 C114	RLM 70	H65 C18	WHITE	H11 C62
RLM 74	H68 C36	RLM 75	H69 C37	RLM 76	H417 C117	RLM 02	H70 C60

B Flown by Maj. J. Trautloft, CO of JG 54, Soviet Union, early 1943

Holder of the Knight Cross, Johannes Trautloft, was born on the March 3rd 1912, in Thüringian Grossobringen. On the April 1st, 1931 Trautloft started transport aircraft pilot training. This was followed by fighter pilot training and later assignment during the Spanish Civil War, where Trautloft participated as a member of the Condor Legion. During the Civil War he achieved five victories, and he also participated during WWII as combatant with 2./JG 77. Shortly thereafter, he took command of 1./JG 20, which thus became III./JG51 in July 1940, transformed into III./JG 51. On August 25th, 1940 Trautloft became Commodore of the new JG 54. In this, he dutifully served until July 5th, 1943, when he was assigned as Inspekteur der Jagdflieger – Ost. He was active during the so-called „Fighters uprising“ in 1945. After this failed, Trautloft was reassigned to 4. Fliegerschule Division, where he stayed until the end of the war. During the sixties he served as Chief Inspector of Bundesluftwaffe. Until his passing on January 11th 1995, he was active in various veteran organizations. The depicted Focke-Wulf flown by „Hannes“ Trautloft has its upper sides overpainted by a washable white distemper for better winter camouflage. The individual marking consists of Geschwader Commandeur ID symbol and the emblem of Stab./JG 54. Yellow wingtips and fuselage band reveal an assignment to the Eastern front. Part of the engine cowling is presumably cannibalized from another aircraft, and is not overpainted by the white color.

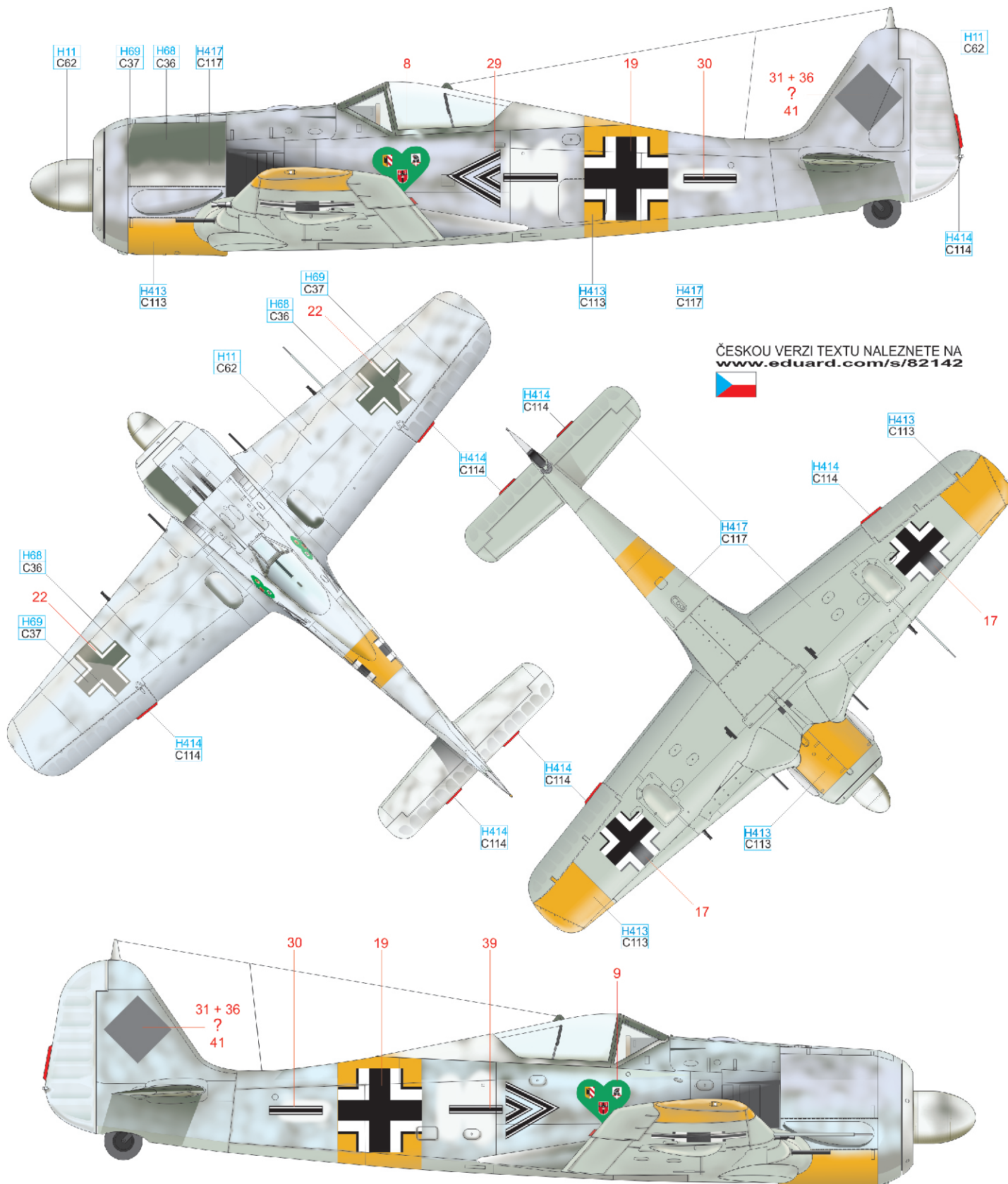

RLM 04	H413 C113	RLM 23	H414 C114
RLM 74	H68 C36	RLM 75	H69 C37
	RLM 76	H417 C117	WHITE
		H11 C62	

On November 8th, 1942 the Allied forces, under the command of Gen. Eisenhower, invaded French Algeria. Due to the demand of Luftwaffe transport aircraft protection, II./JG 2, equipped by Fw 190A-3, was relocated to this theatre. In December 1942 some Fw 190A-4 were supplied to the unit. Their duty was not only to protect multi-engine aircraft transporting troops and equipment, but also to attack various targets on land, controlled by Allied forces. On the March 22nd, 1943, the entire II./JG 2 left North Africa and moved back to France. During their Algerian assignment, II. Gruppe achieved 121 victories with the loss of 16 Focke-Wulf aircraft and 6 pilots. Oblt. Rudorffer managed to increase his score by 25 victories. Focke-Wulf aircraft delivered at this time to the II./JG 2, were camouflaged in standard scheme RLM 74/75/76. On the Algerian fields, their upper surfaces were over-sprayed with RLM 79. The rear fuselage wore a white band, as per MTO identification marking.

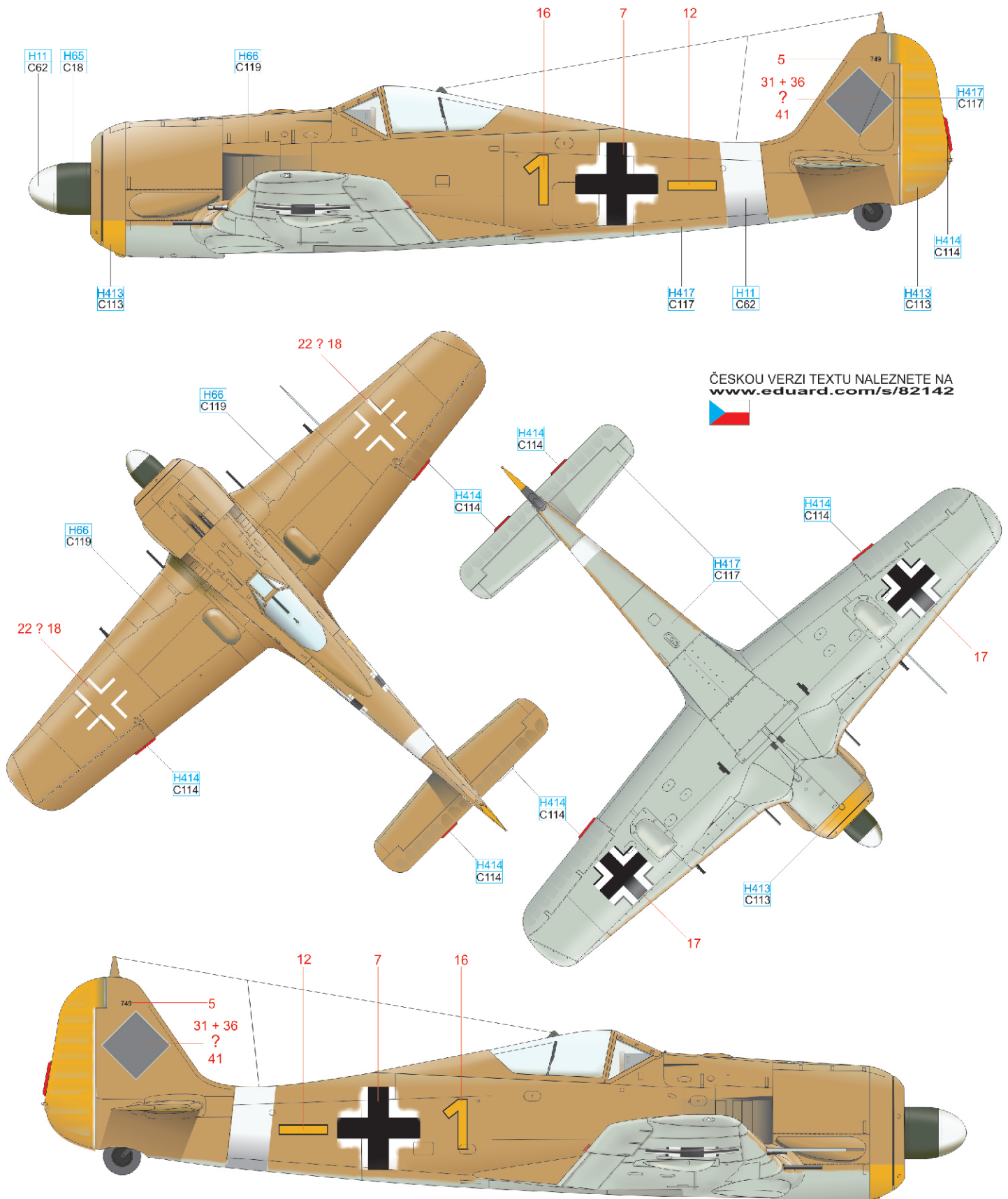

ČESKOU VERZI TEXTU NALEZNETE NA www.eduard.com/s/82142



WHITE	H11 C62	RLM 23	H414 C114	RLM 79	H66 C119
RLM 04	H413 C113	RLM 76	H417 C117	RLM 70	H65 C18

D W. Nr. 760, flown by Fw. R. Eisele, 8./JG 2, Brest-Guipavas, France, January 1943

New Focke Wulf Fw 190A-2 aircraft began to entirely replace the older Messerschmitt Bf 109F in III./JG 2, from May 1942. In the August of the same year, the 7th and 9th Staffel already controlled (with Focke-Wulfs) the skies over Dieppe during the British invasion attempt. The 8th Staffel defended Brest harbor against attacks of Allied bombers and later also covered the U-boat docks at Lorient and St. Nazaire. Within a year, the unit was re-equipped by modern A-3 and A-4 versions of the Fw 190. One of these new Fw 190A-4s was flown by Rudolf Eisele. The plane wore the standard camo scheme of RLM 74/75/76. On the left side of the engine, the red wolf was applied, being the emblem of 8. Staffel/JG 2. Eight bars on the rudder indicates Eisele's victories up to January 26th, 1943.

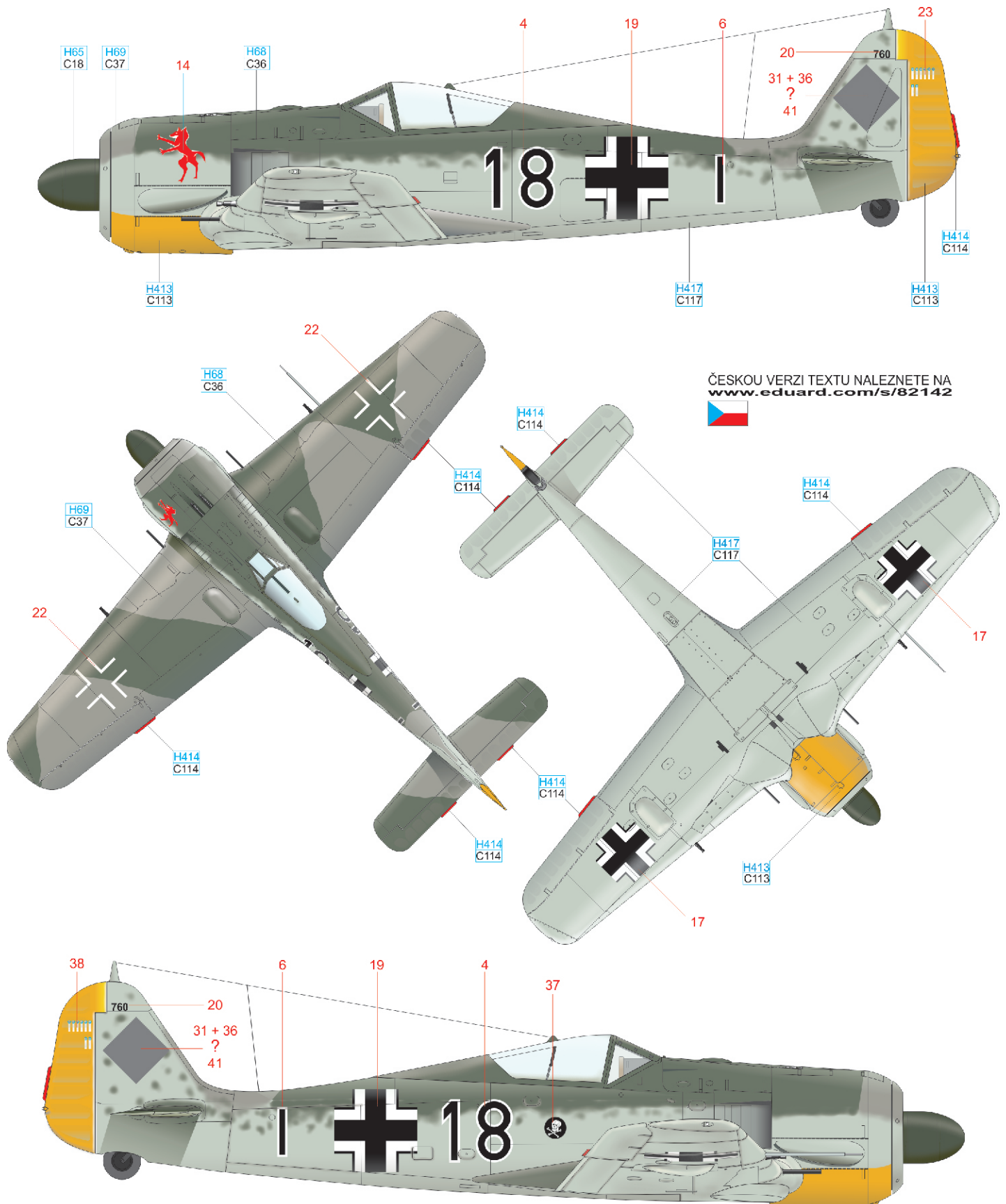

RLM 04	H413 C113	RLM 23	H414 C114	RLM 70	H65 C18
RLM 74	H68 C36	RLM 75	H69 C37	RLM 76	H417 C117

E Flown by Oblt. W. Nowotny, CO of 1./JG 54, Staraya Russa, Soviet Union, March 1943

A German fighter pilot of Austrian descent and a native of Gmünd situated near the border with Czechoslovakia, Walter 'Nowi' Nowotny was a holder of the Knight's Cross with Oak Leaves, Swords and Diamonds, and shot down 258 enemy aircraft over the course of 442 combat sorties. He was killed in an Me 262 Schwalbe in combat with American escort fighters near an airfield at Hesepe on November 8th, 1944. During the winter season, the Luftwaffe on the Eastern front camouflaged their aircraft in white. It was applied either as an entire over-painting of the upper surface, or in the shape of various white patches. The mount of Walter Nowotny wore a camo scheme composed mostly of green and brown colors on the upper side of the wings and of the fuselage, which was then partially overpainted by patches of washable white color. The airplane wore markings for the Eastern Front, consisting of yellow wingtips, including part of the rudder and the fuselage band. In the case of JG 54, this was applied behind the Balkenkreuz. The green heart on the fuselage is the emblem of JG 54. The emblem of I. Gruppe is applied on the engine cowling.

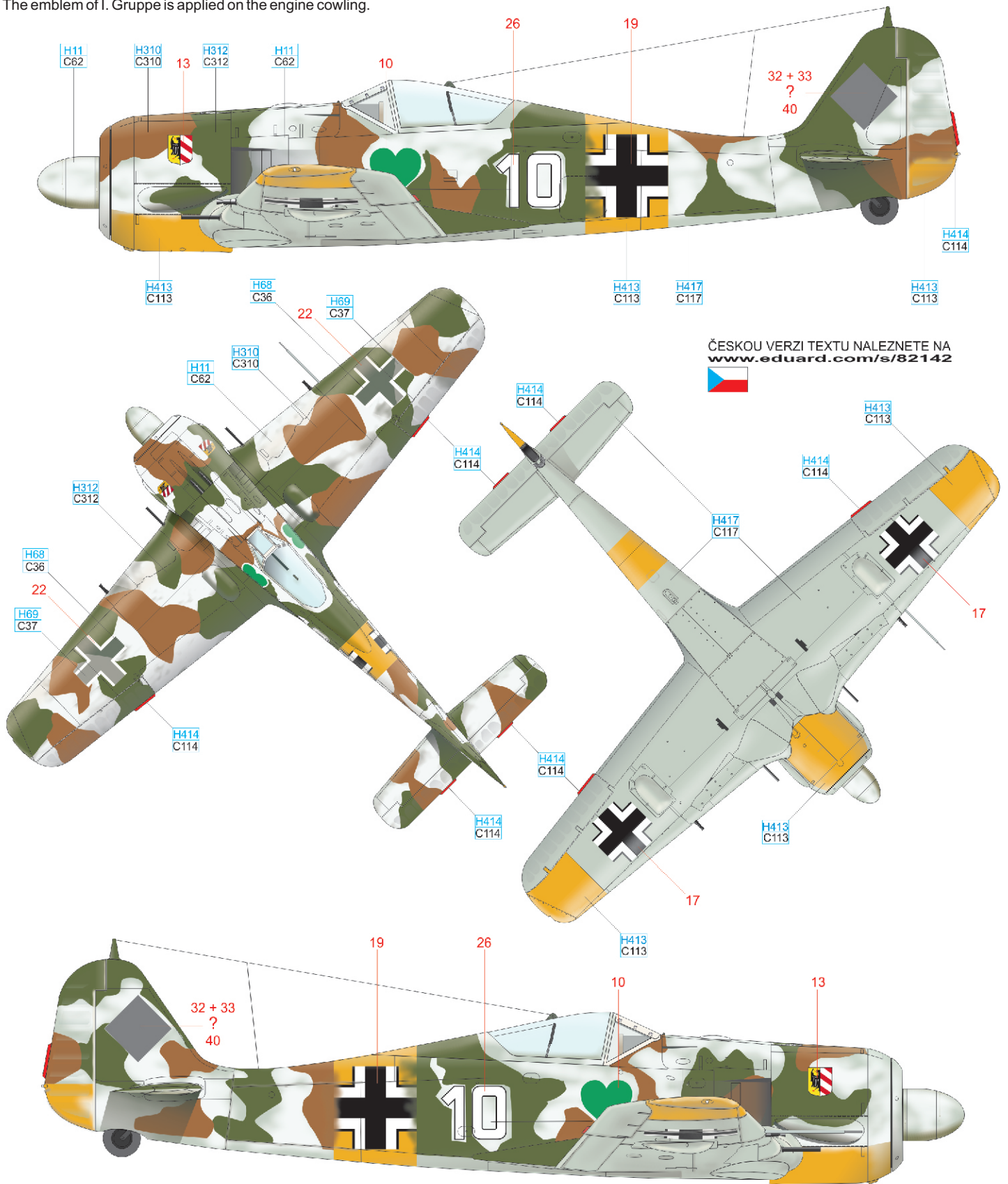

GREEN	H312 C312	WHITE	H11 C62
RLM 04	H413 C113	RLM 23	H414 C114
RLM 74	H68 C36	RLM 75	H69 C37
		RLM 76	H417 C117
			H413 C113

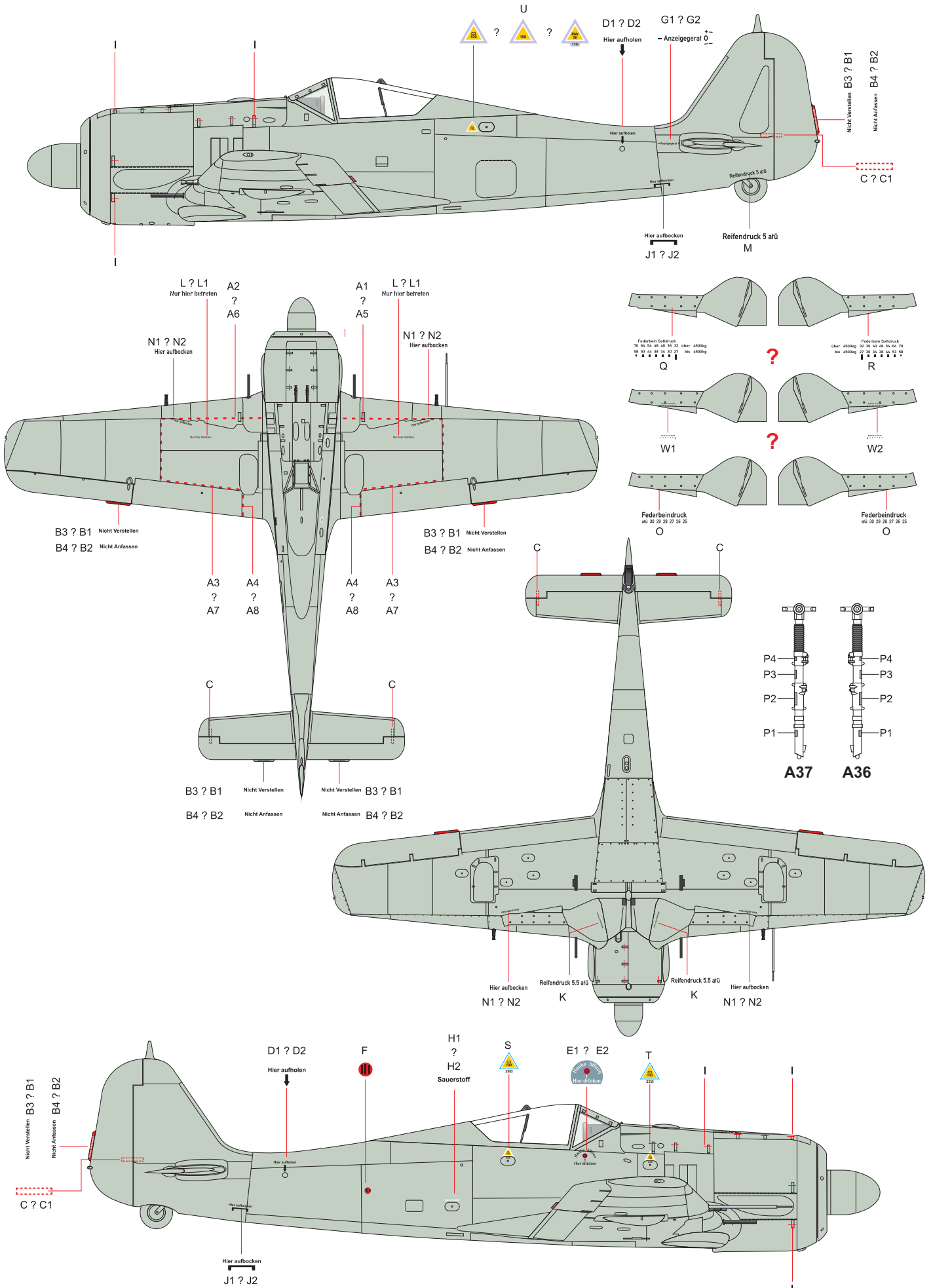

Fw 190A-4

1/48

#82142

ProfiPACK
edition

RELATED PRODUCTS:

- 48936 Fw 190A-4 landing flaps (PE-set)
- 48937 Fw 190A-4 (PE-set)
- FE863 Fw 190A seatbelts STEEL (PE-set)
- 648351 Fw 190A-4 cockpit (Brassin)
- 648352 Fw 190A-4 engine (Brassin)
- 648354 Fw 190A-4 fuselage guns (Brassin)
- 648355 Fw 190A-4 engine & fuselage guns (Brassin)
- 648356 Fw 190A wingroot gun bays (Brassin)
- 648152 Fw 190 wheels early (Brassin) 2017/11

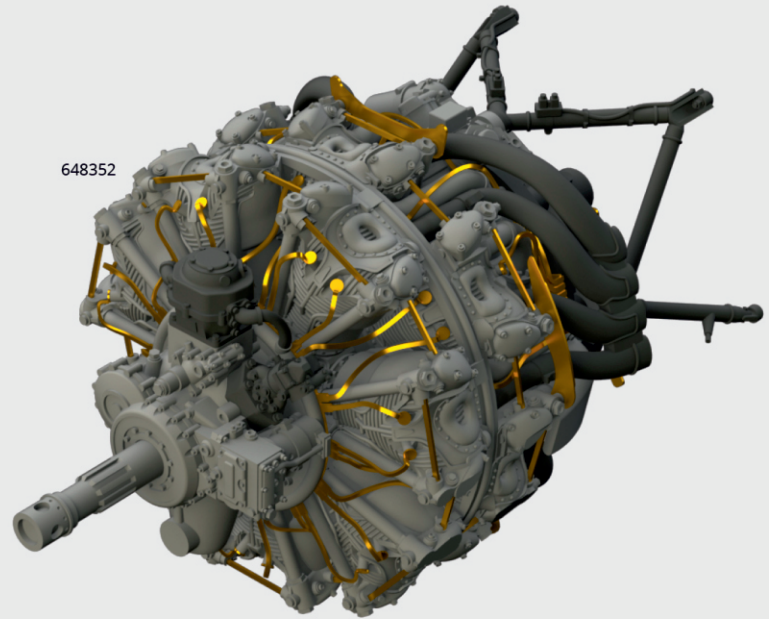

648352

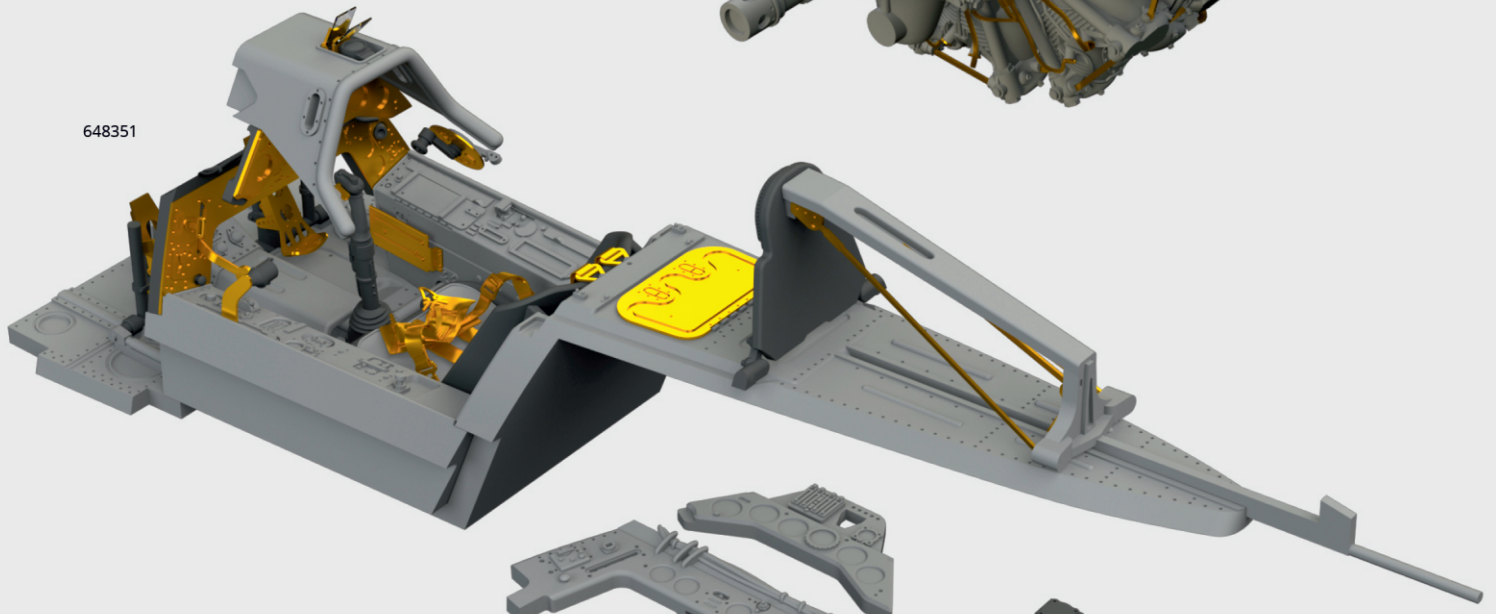

648351

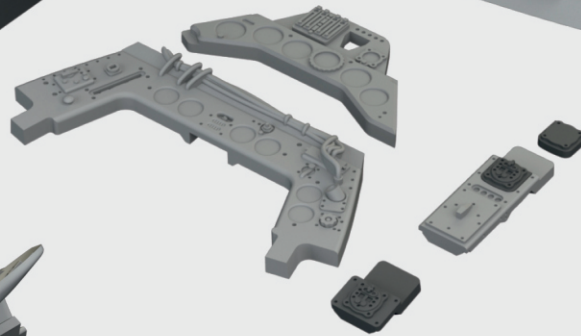

648354



648356

