

35 K21

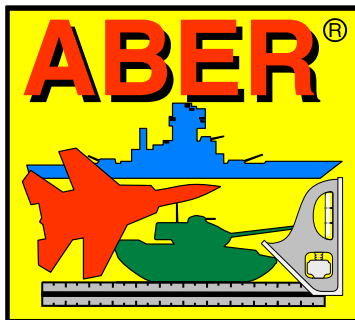

EXCLUSIVE EDITION

UPGRADE SET
FOR TAMIYA
1/35 MODELS

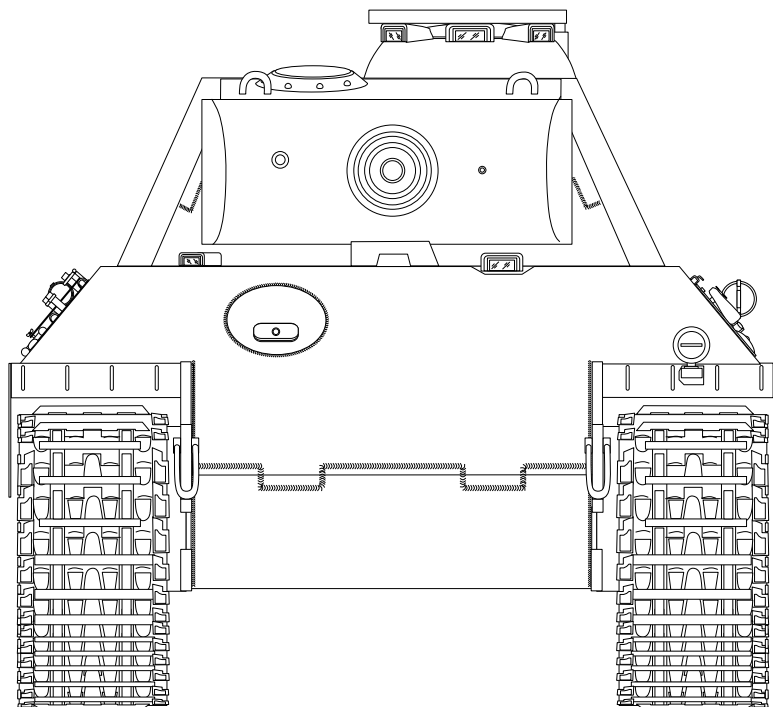

GERMAN MEDIUM TANK PANTHER G

Pz.Kpfw. V (Sd.Kfz. 171) - Ausf. G

Niemiecki średni czołg Sd.Kfz. 171 "Panther G"

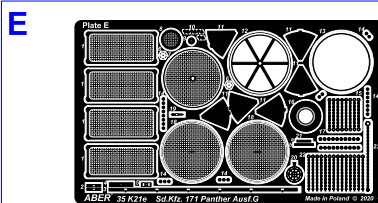
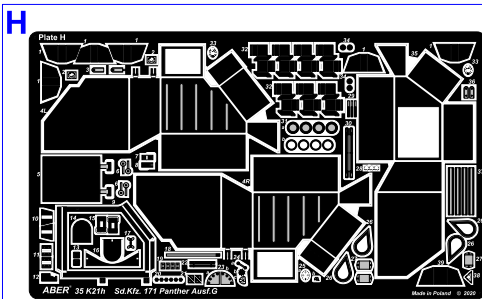
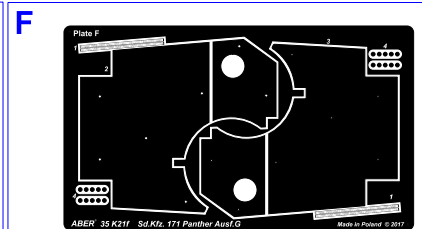
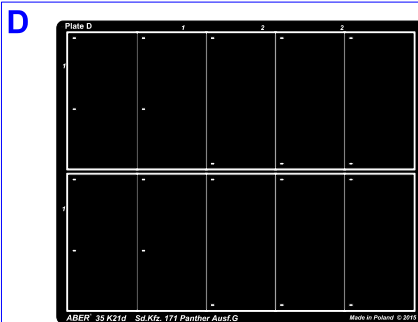
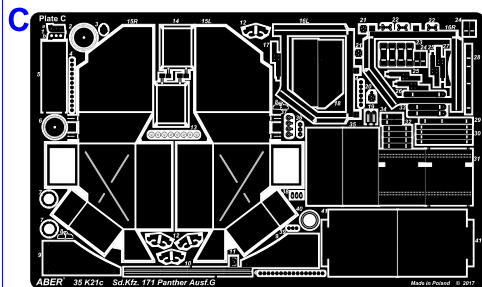
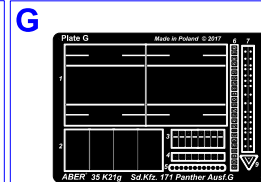
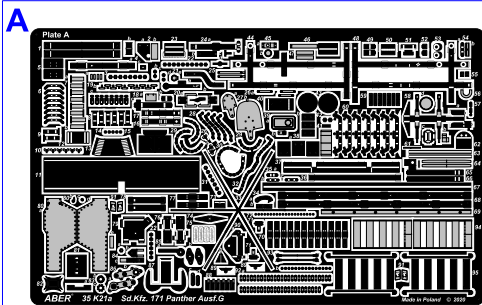

Bag with wood
chock

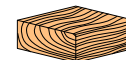

Bag with cable & wires

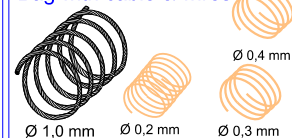

Bag with barrel, antennas, tubes and rods

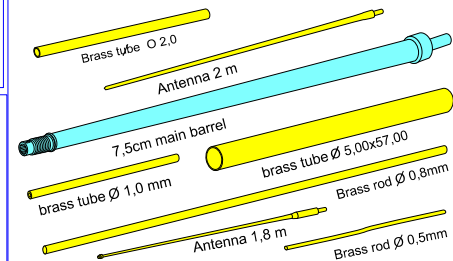

Turned brass parts

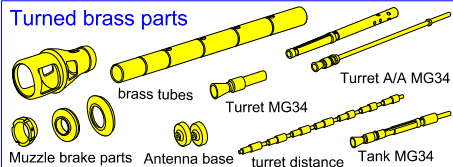

MOST IMPORTANT BIBLIGRAPHY:

- 1) Sd.Kfz.171; Pz.Kpfw.V PANTHER - Waldemar Trojca - "Trojca" ©2003
- 2) Achtung Panzer No.4 - PANTHER, Jagdpanther & Brumbär by Mitsuru Bitoh - Dai Nippon Kaiga Co.,Ltd. ©1994
- 3) GROUND POWER No.024, 079 - Delta Publishing Co.,Ltd. ©1996, ©2000
- 4) Militärfahrzeuge Band 9; Der Panzer-Kampfwagen Panther und Seine Abarten - Walter J. Spielberger - Motorbuch ©1994
- 5) Panther in Detail - B. Culver & U. Feist - Ryton Publications ©1998
- 6) Panzer Tracts No.5-3 - Thomas L. Jentz & Hilary Louis Doyle
- 7) New Vanguard 22: PANTHER VARIANTS 1942-1945 - Osprey Military ©1997
- 8) AFV Modeling Guide Vol.3 PANTHER - Geibun Mooks ©2009
- 9) Military Detail Illustration Panzerkampfwagen V PANTHER -Shingensha Co Ltd ©2014
- 10) The Research Squad = Panther Project - Vol. 1 and 2 and next

Thank you for purchase our set 35 [K21](#)

Read carefully this instruction. Scour metal parts before using
We advise that better method to join metal to metal parts is soldering.
Cement metal parts to plastic with good cyanoacryl or epoxy glue.

WARNING

Any unauthorized copying, producing and reproducing of ABER company products, or any part thereof, is strictly prohibited and any such action establishes liability for a civil action and may give rise to criminal prosecution.

Please note that, for purpose of improvement ABER sets designs are subjects to change without notice.

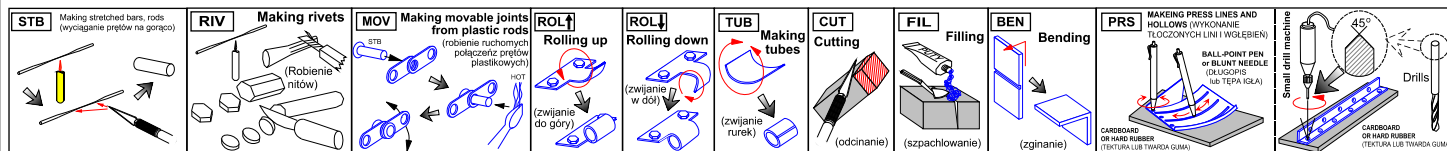

TOOLS RECOMMENDED
Rekomendowane narzędzia

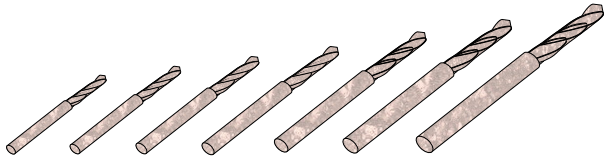

Drills from \varnothing 0,4 to 1,5 mm



Assortiment of cutting wheels and mills

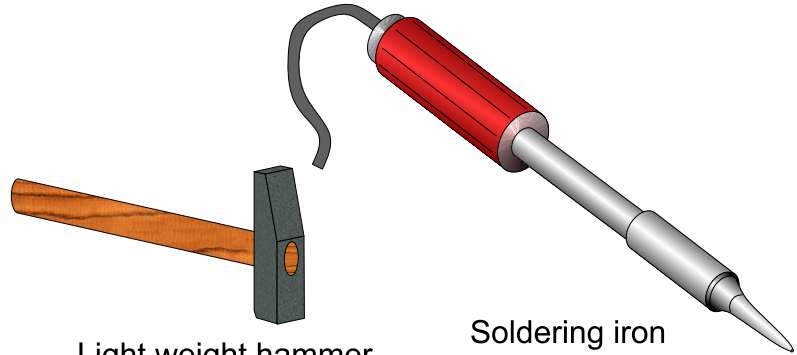

Light weight hammer

Soldering iron

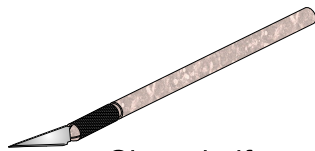

Sharp knife

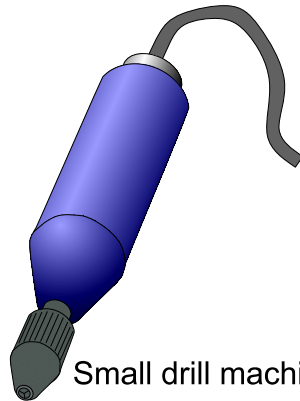

Small drill machine

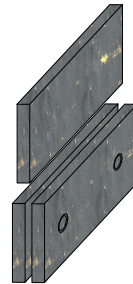

Bending tool
PG01 or PG02



Soldering flux



Solder

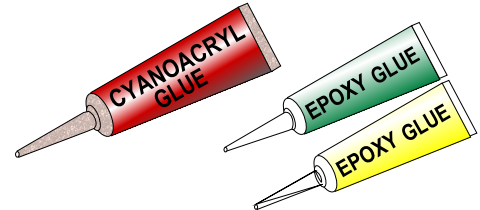

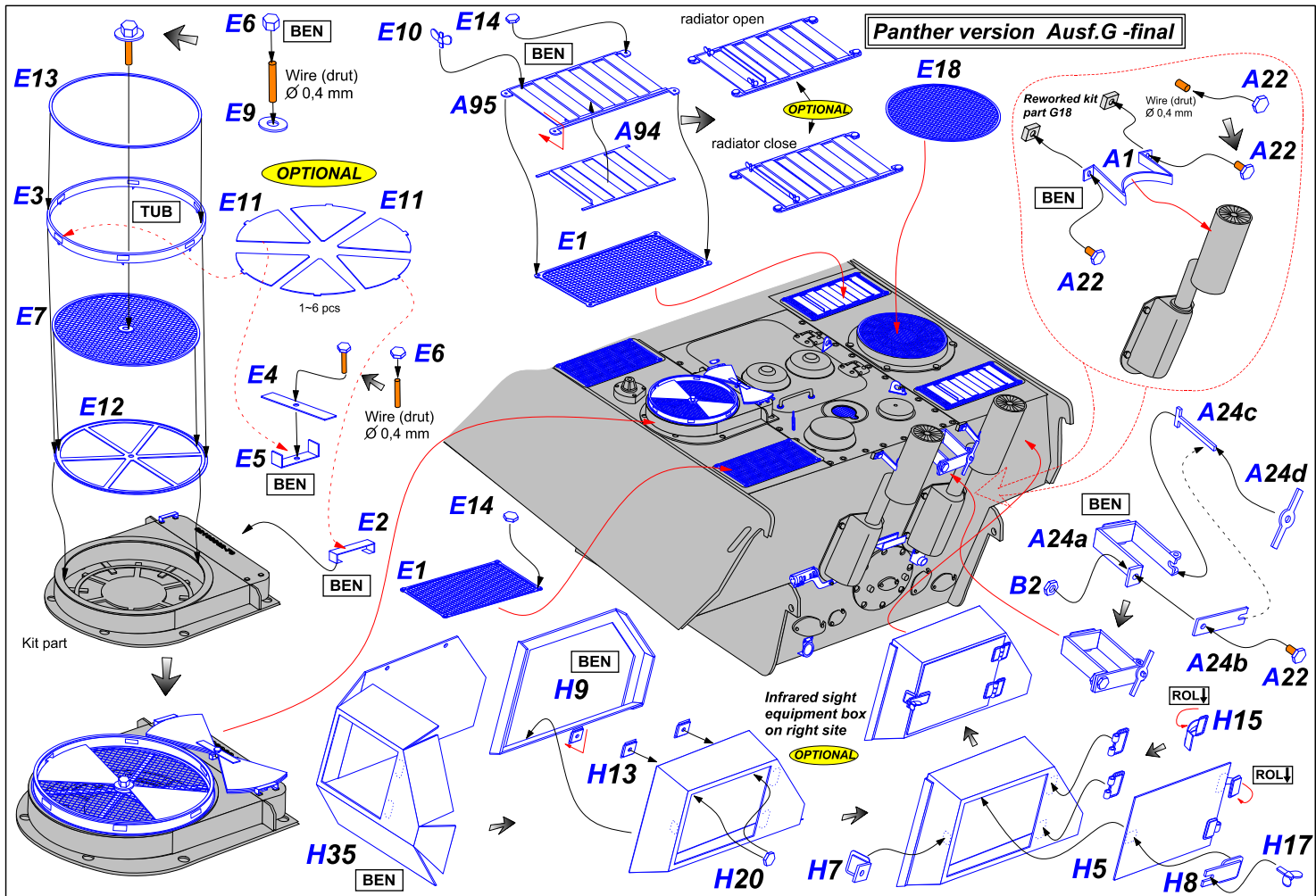

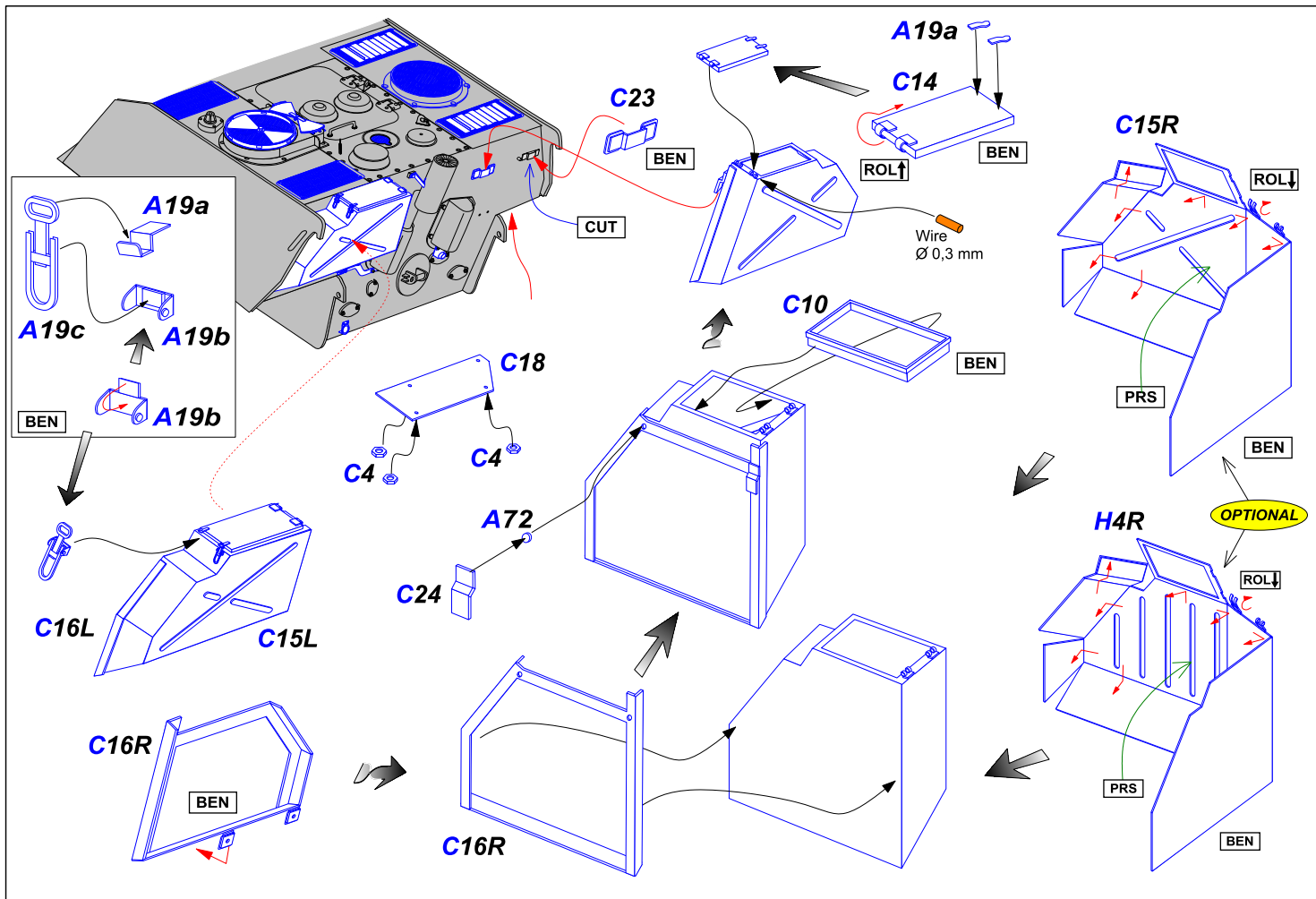

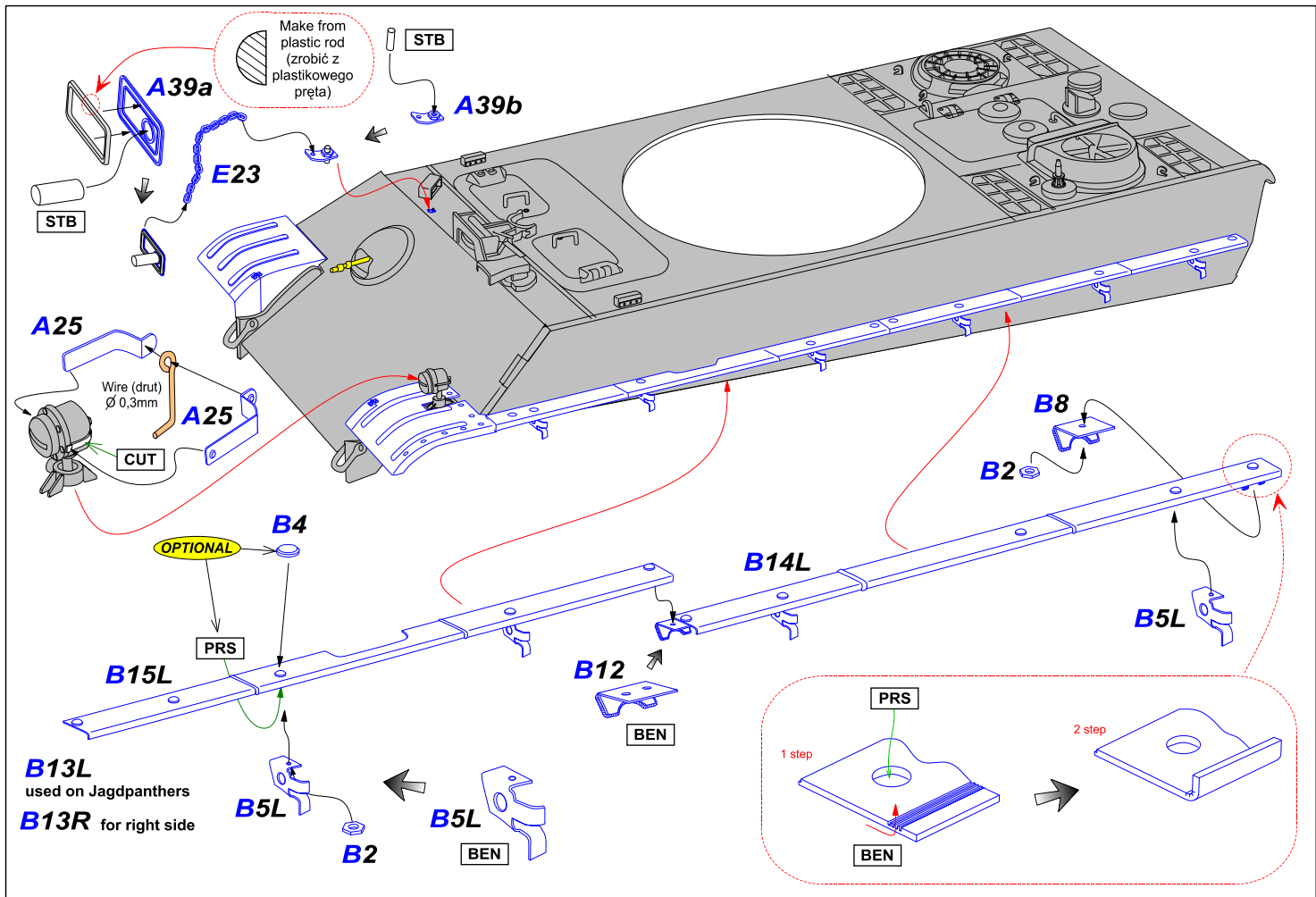

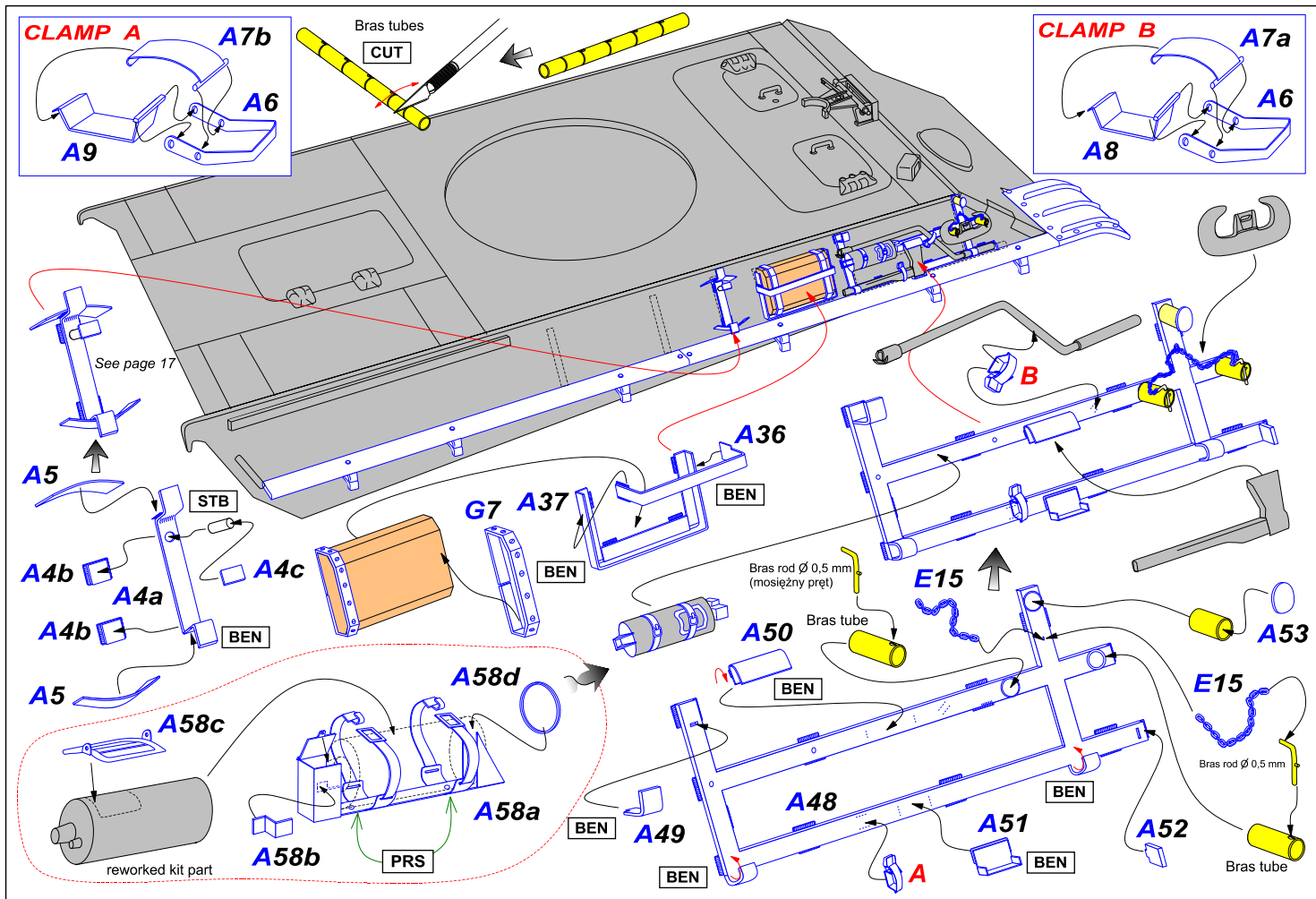

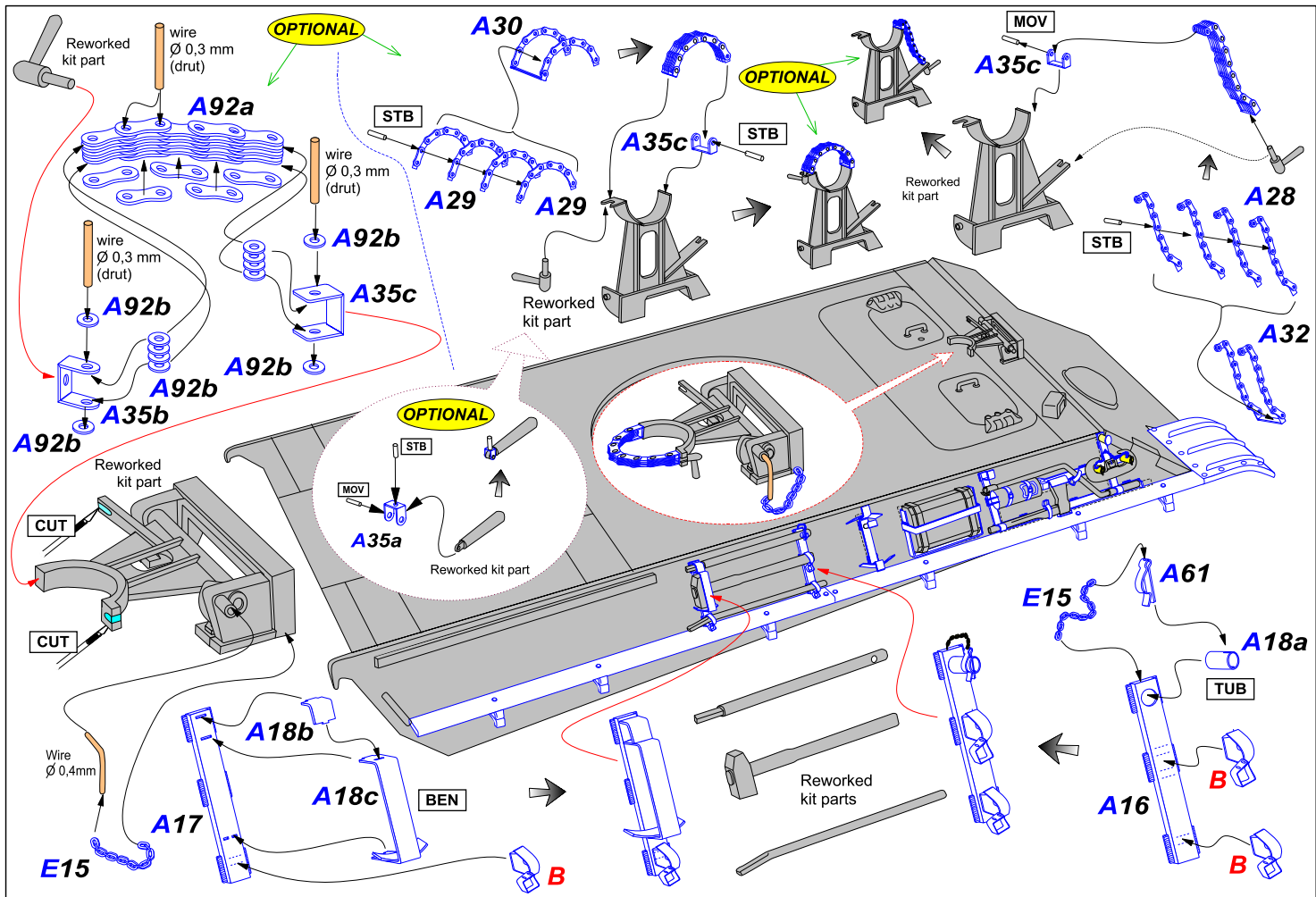

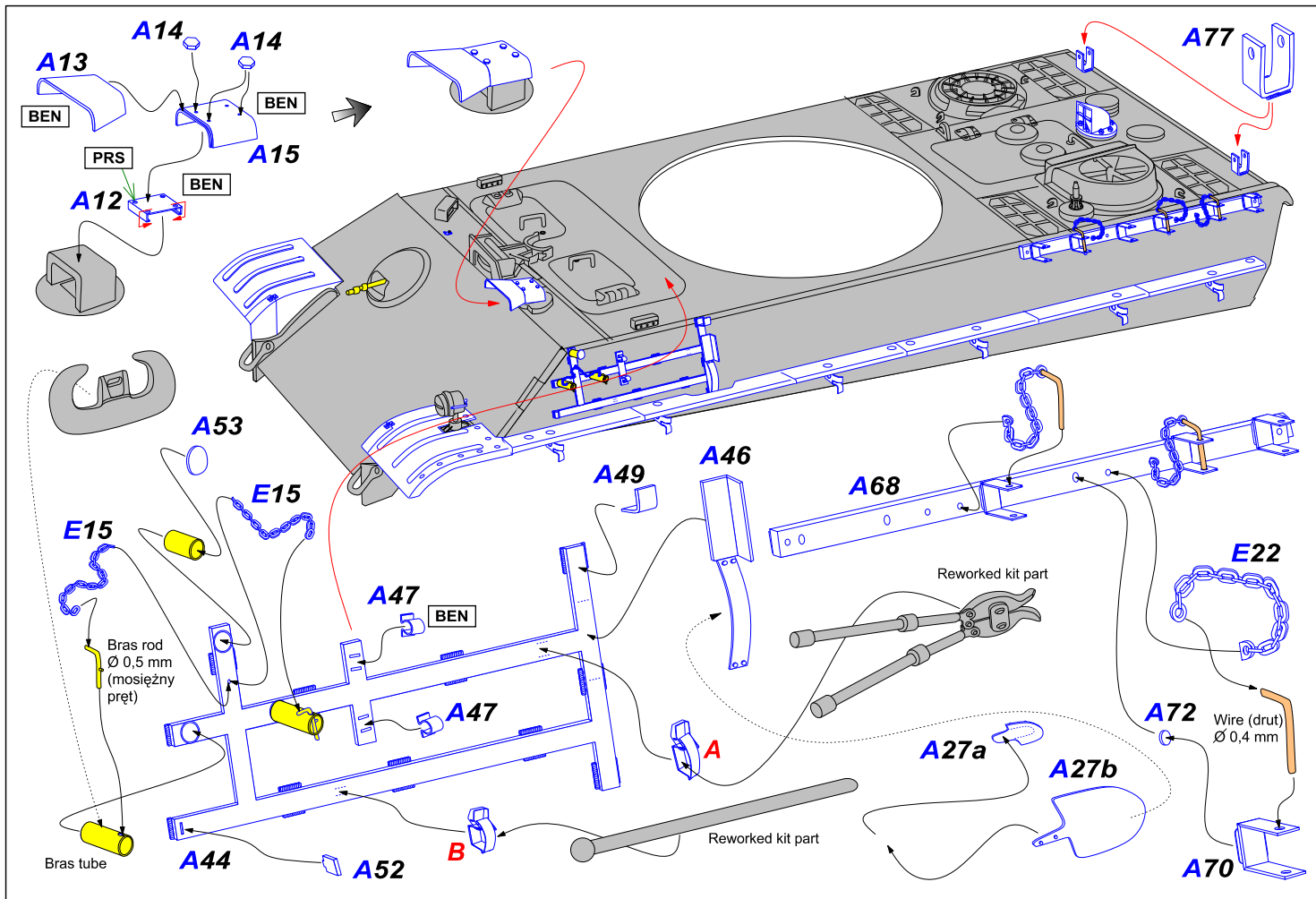

Panzerbefehlswagen all version

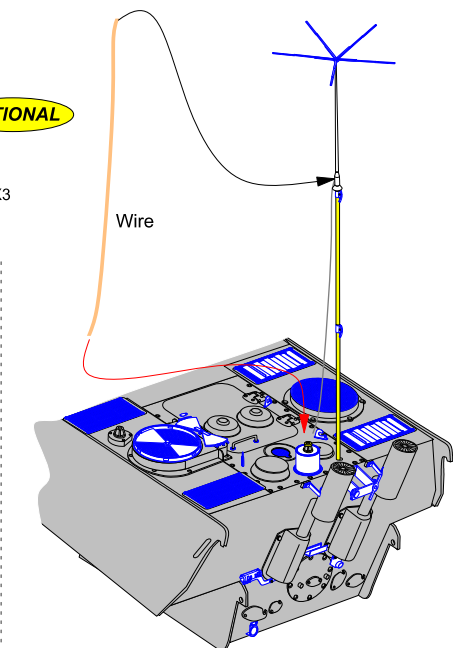
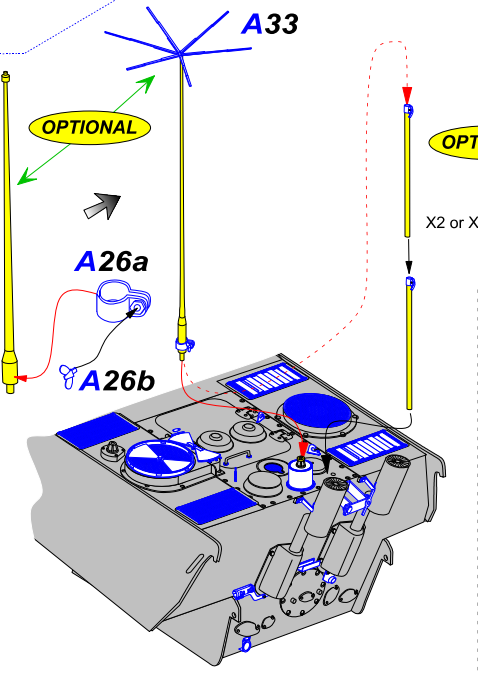
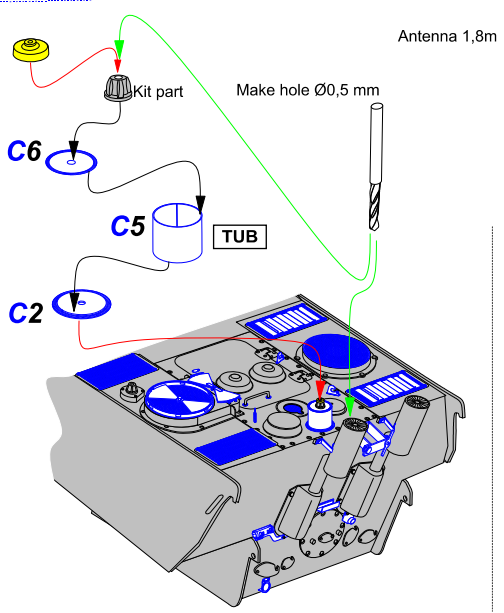
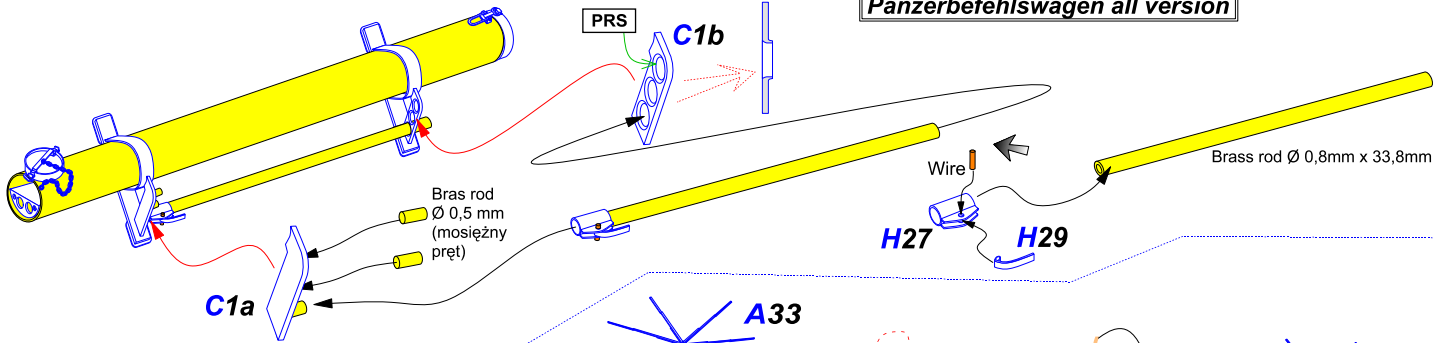

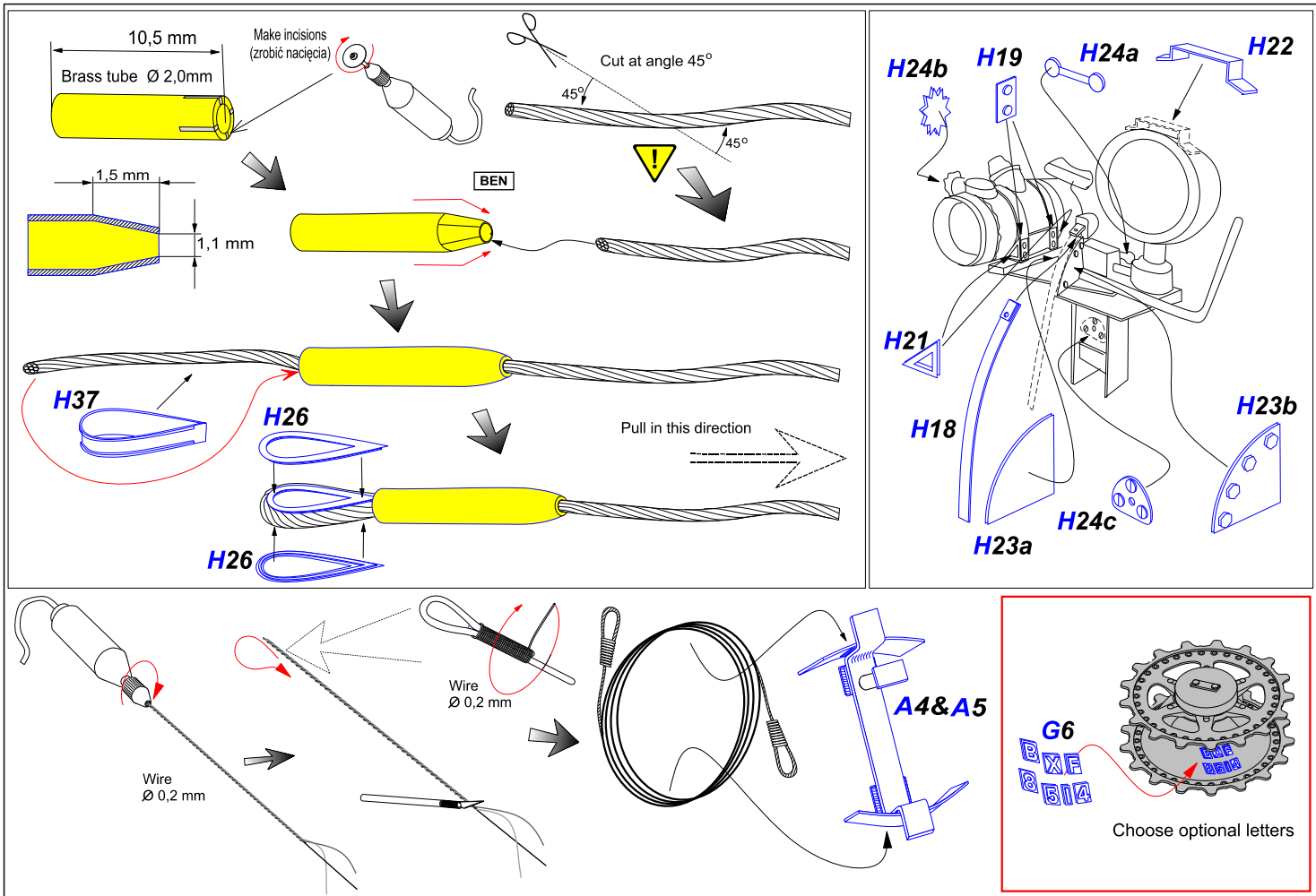

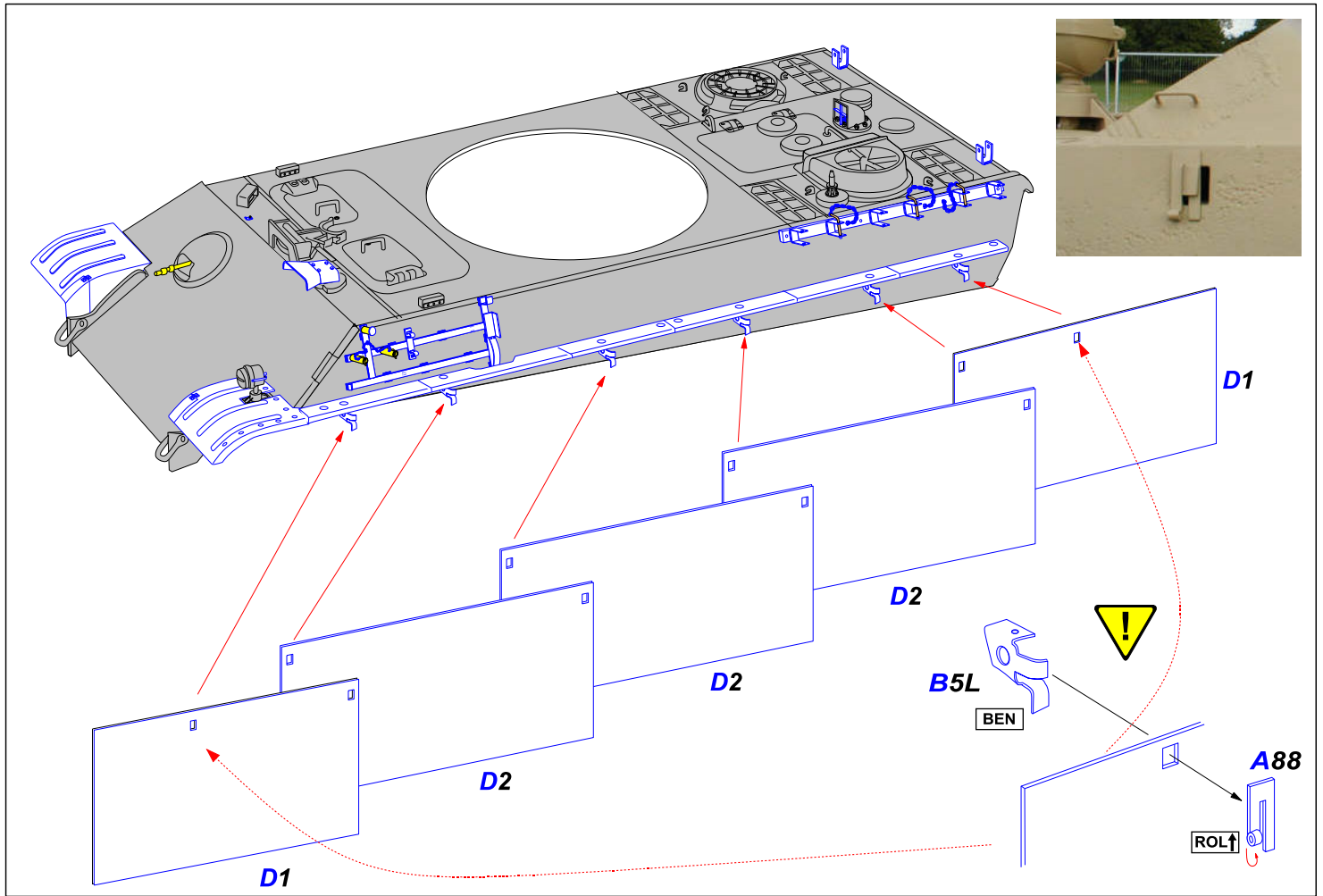

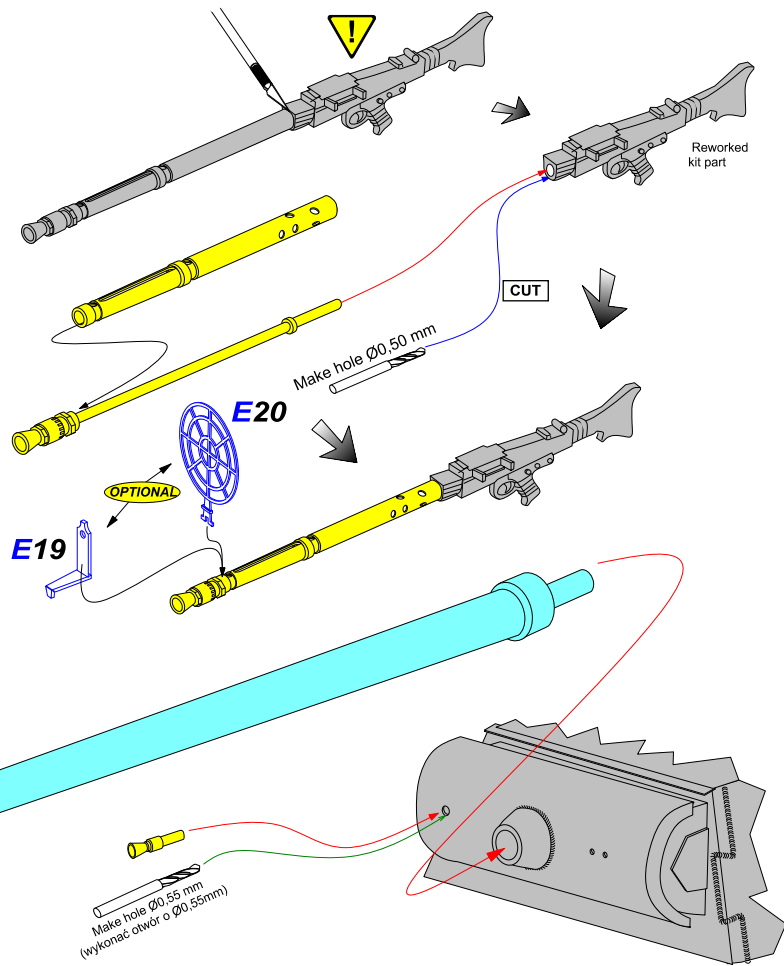
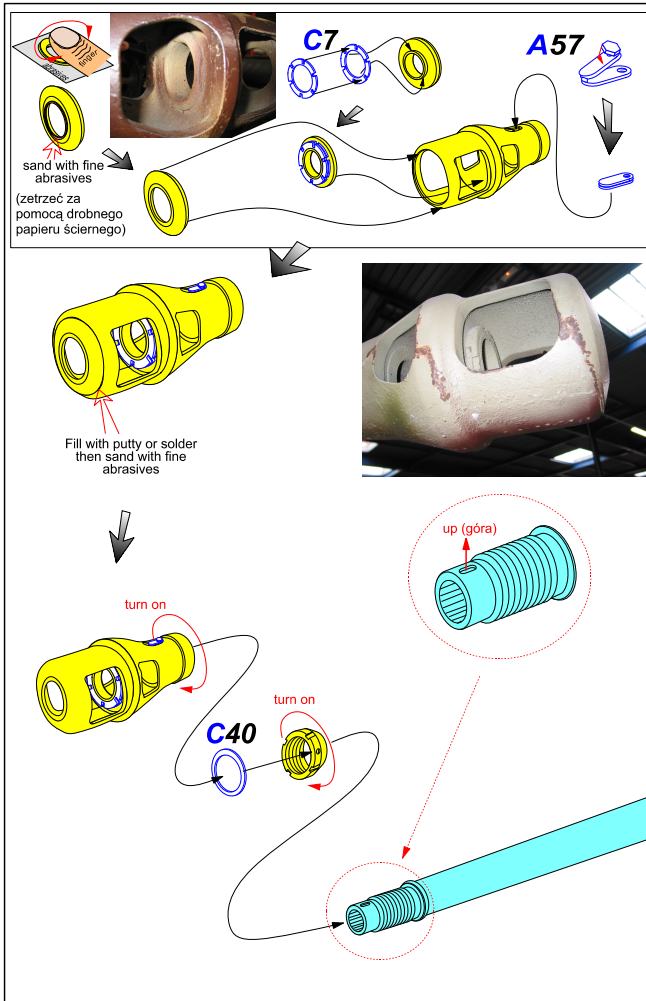

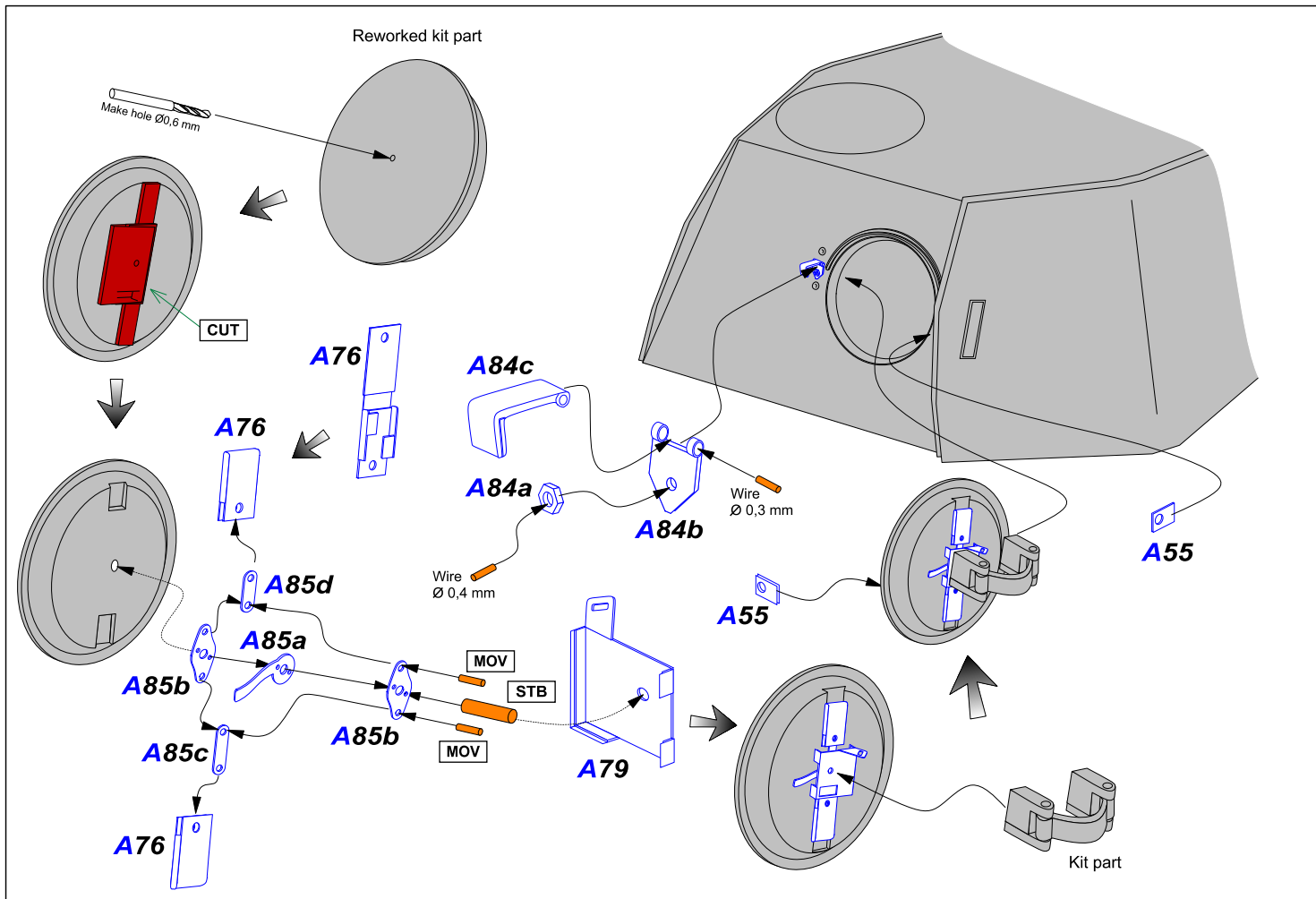

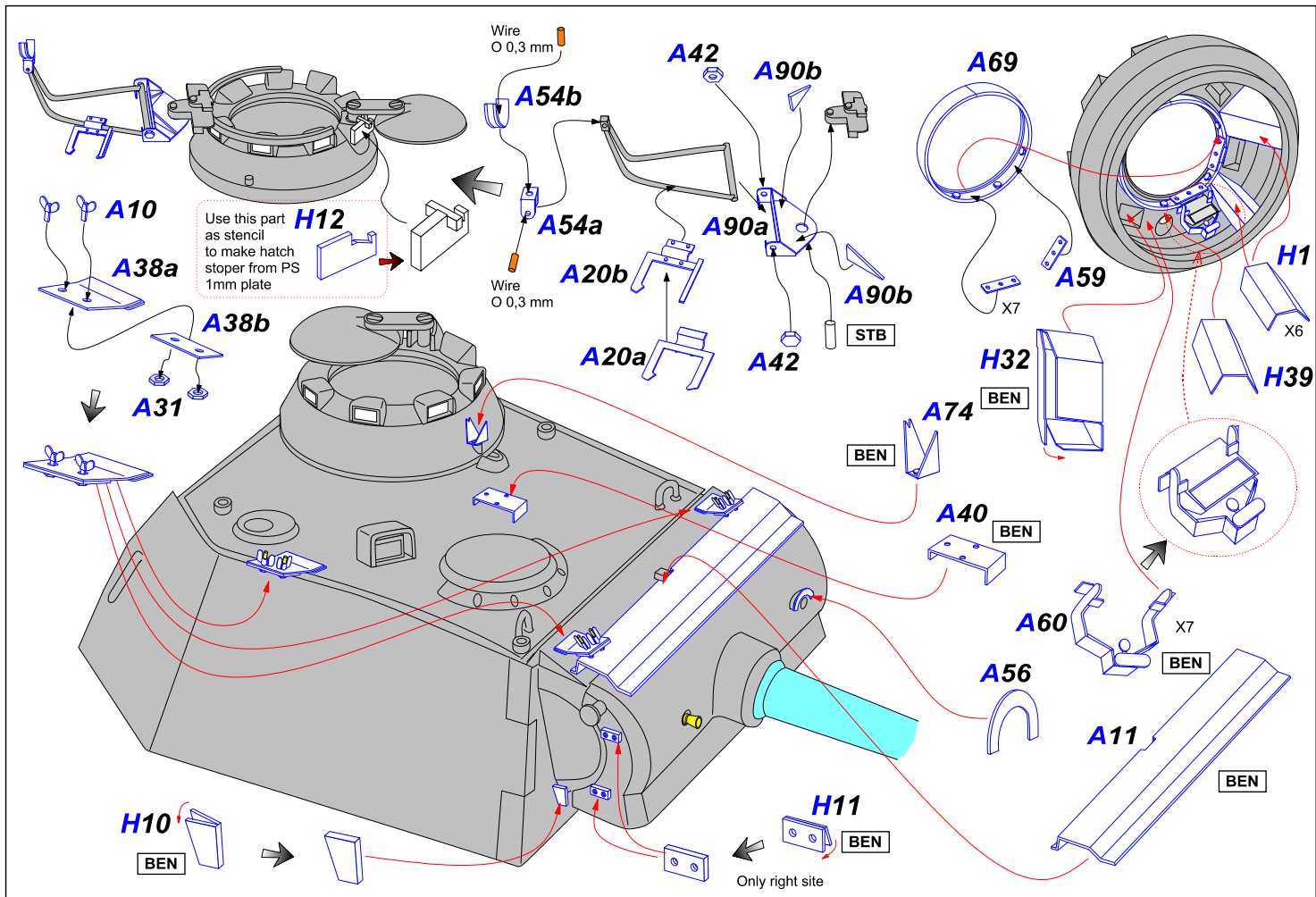

Make hole $\varnothing 0,5$ mm and then light cavity $\varnothing 1,1$ mm (wykonać otwór a następnie lekkie wgłębienie)

Use part F3 as stencil and mark holes (Część F3 użyć jako szablon do zaznaczenia otworów)

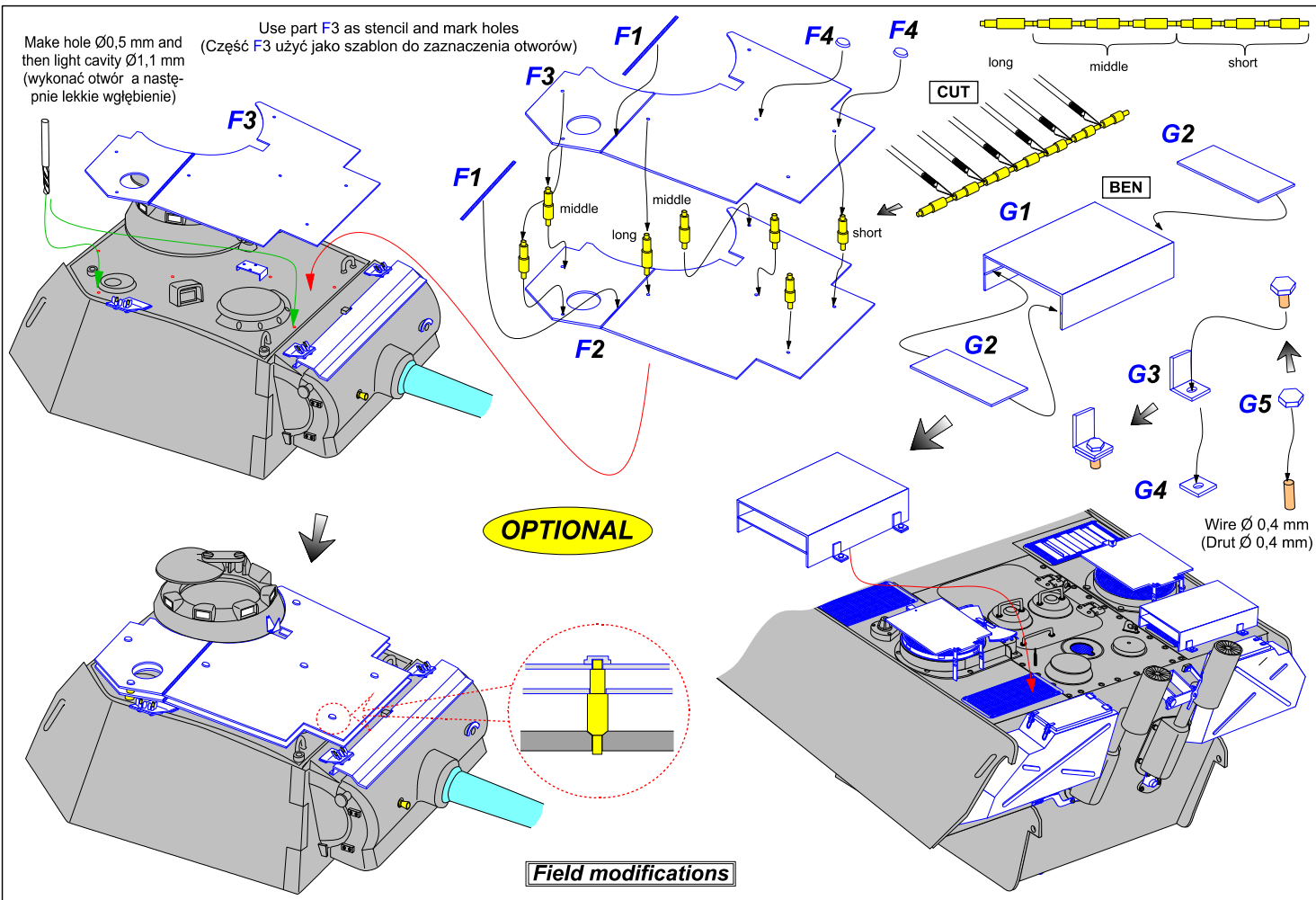

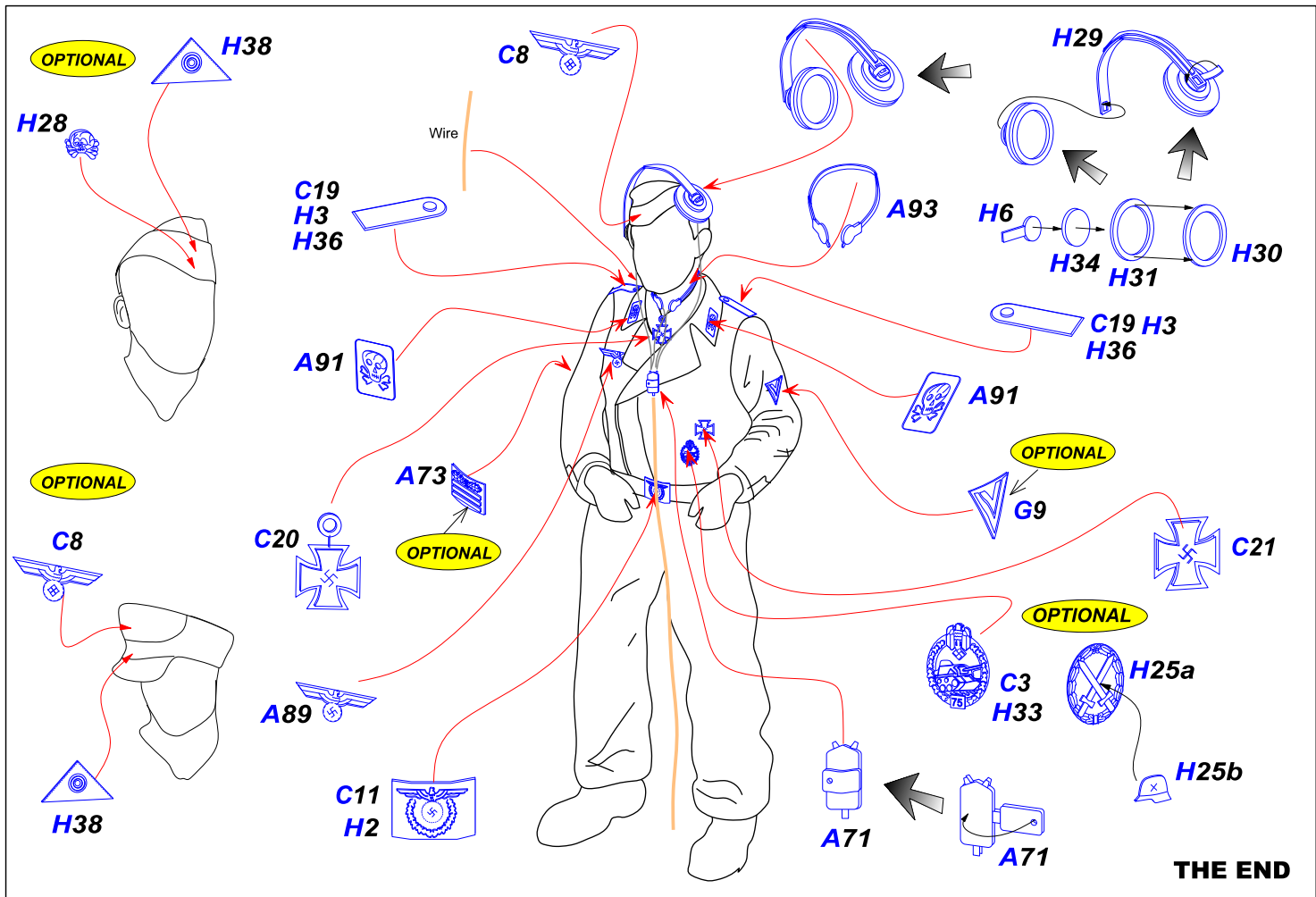

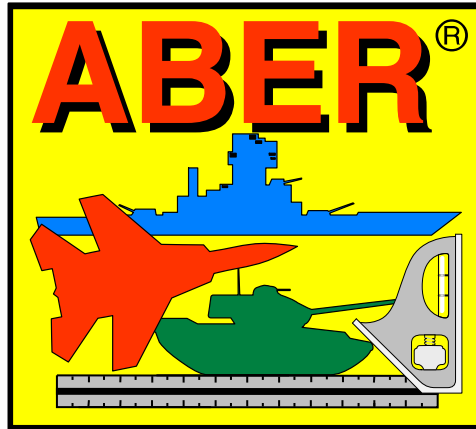

WWW.ABER.NET.PL