

MODEL KIT / MODELLE REDUIT / MODELL BAUSATZ
1/72 ÖLÇEK / SCALE / MASSTAB / ECHELLE

F-35A LIGHTNING II

F-35 Lightning II, JSF "Müşterek Saldırı Uçağı" programı kapsamında üretilen, kara saldırı ve hava üstünlüğü görevlerini yerine getirmek için tasarlanmış ,stealth (radara yakalanmayan) ,çok maksatlı 5. nesil savaş uçağıdır. F-35A; geleneksel kalkış ve iniş (CTOL), F-35B; kısa kalkış ve dikey iniş (STOVL), F-35C; uçak gemileri için tasarlanmıştır. F-35A (AA-1) ilk uçuşunu 15 Aralık 2006'da tarihinde gerçekleştirmiştir. Uçağın geliştirme projesinde 9 ülke içerisinde Türkiye'de yer almaktadır. (Amerika Birleşik Devletleri, İngiltere, Hollanda, Türkiye, Kanada, Avustralya, Kanada, Danimarka, Norveç)

F-35 savaş uçaklarında AN/APG-81 AESA radarı kullanılmaktadır ve bu radar F-22 Raptor'da kullanılmakta olan AN/APG-77 radarının geliştirilmiş versiyonudur. Uçakta bu radar ile entegre çalışan AN/AAQ-37 Dağıtılmış Açıklık Sistemi (DAS), AN/ASQ-239 Barracuda Elektronik Harp ve Karşı Önlem Sistemi, AAQ-40 Elektro-optik Hedefleme Sistemi (EOTS) gibi elektronik harp bileşenleri bulunmaktadır. Ayrıca önceki nesil savaş uçaklarında kullanılan HUD (baş üstü ekran) sistemi yerine Gen III HMDS (Helmet Mounted Display System) adı verilen 3. nesil Kaska Monteli Görüntüleme Sistemi kullanılmaktadır. Günümüzde F-35 en gelişmiş ve önemli 5. nesil savaş uçaklarından bir tanesidir.

TEKNİK ÖZELLİKLER

Mürettebat	: 1
Motor	: P&W F135 AB Turbofan
Uzunluk	: 15,67 m.
Kanat Açıklığı	: 10,65 m.
Yükseklik	: 4,33 m.
Boş Ağırlık	: 14.588 kg.
Yüklü Ağırlık	: 22.470 kg.
Azami hız	: 1,6 Mach (1.932 km/h)
Menzil	: 2.200 km.
Servis Tavanı	: 18.288 m.

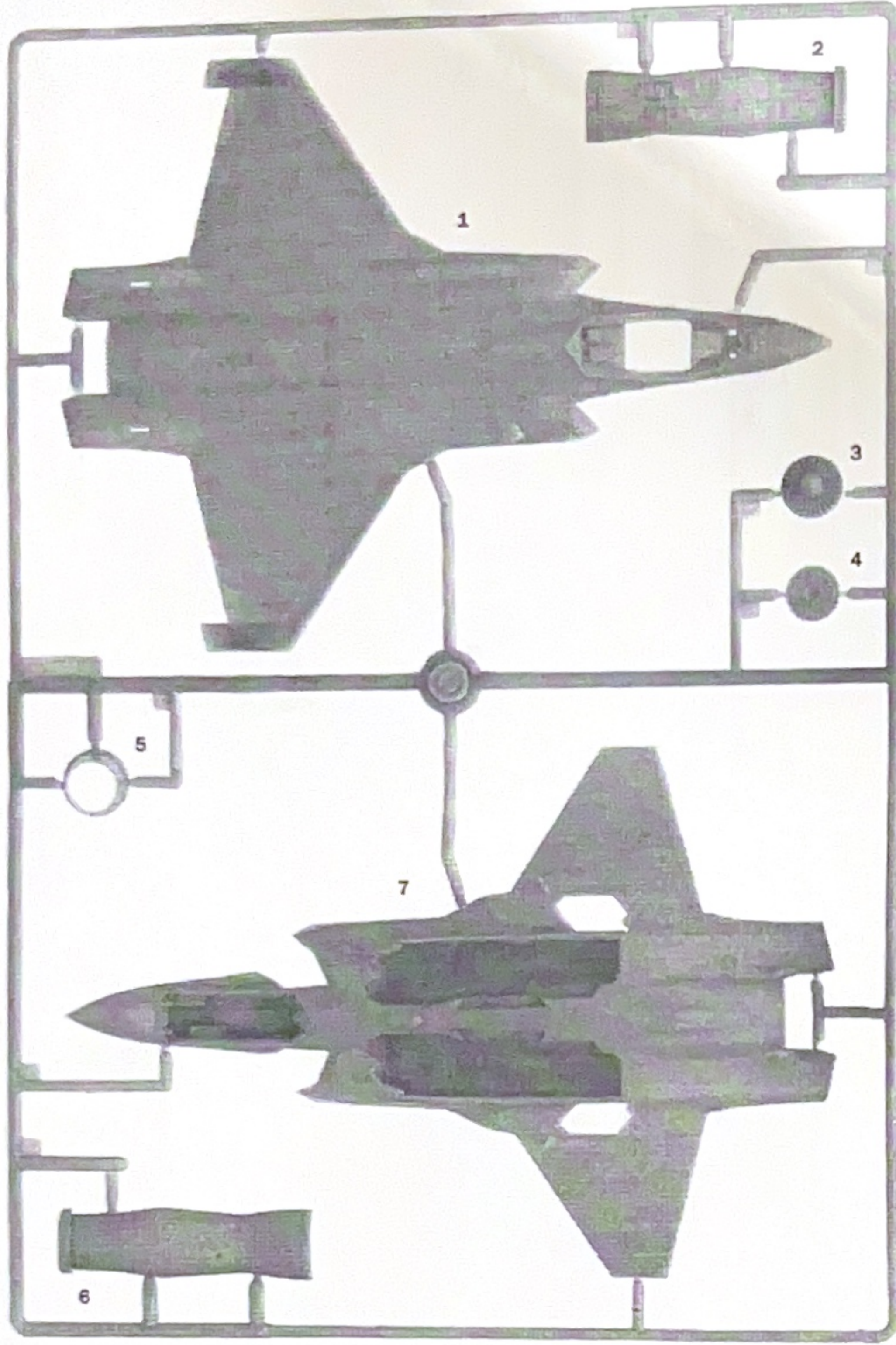
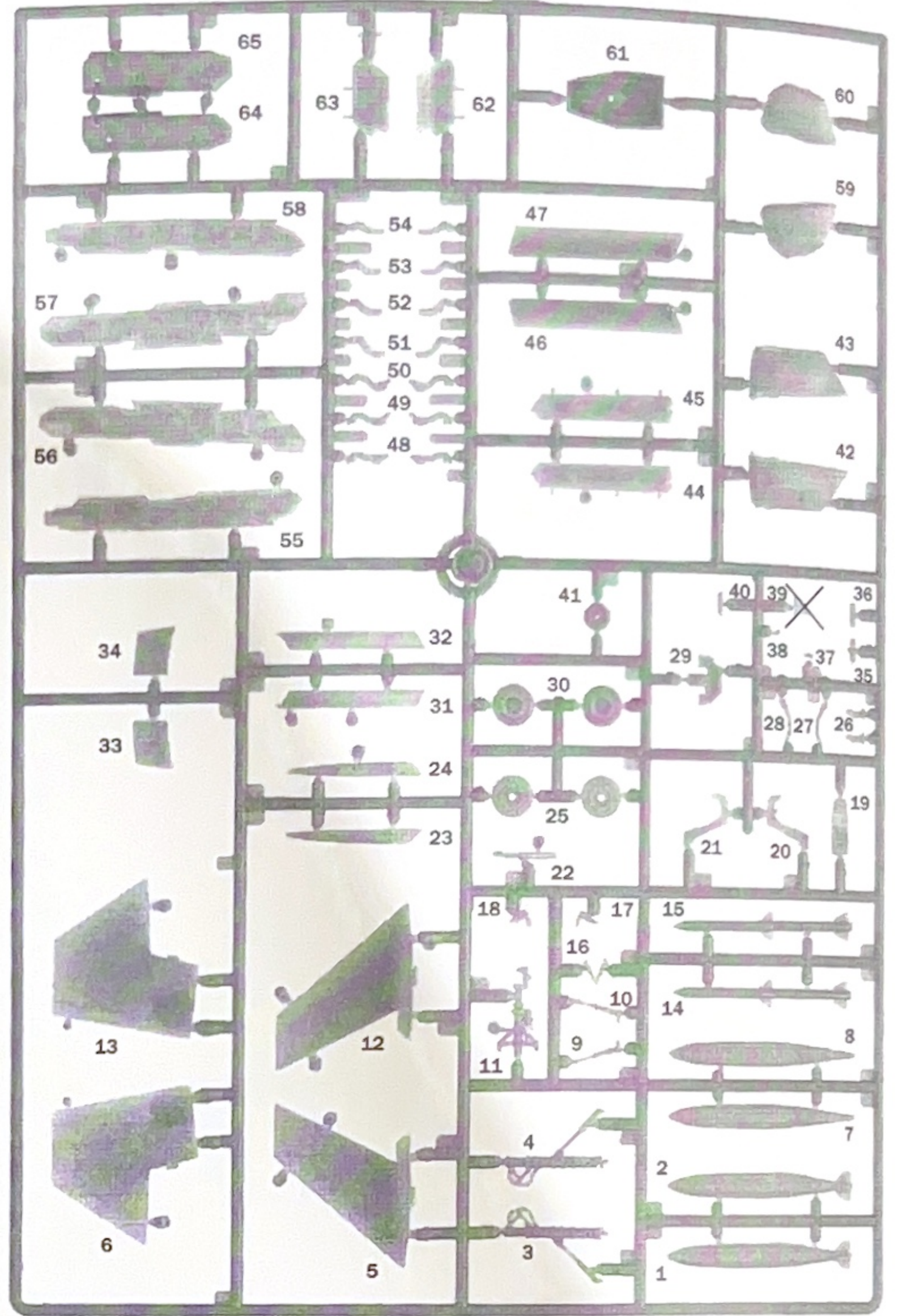
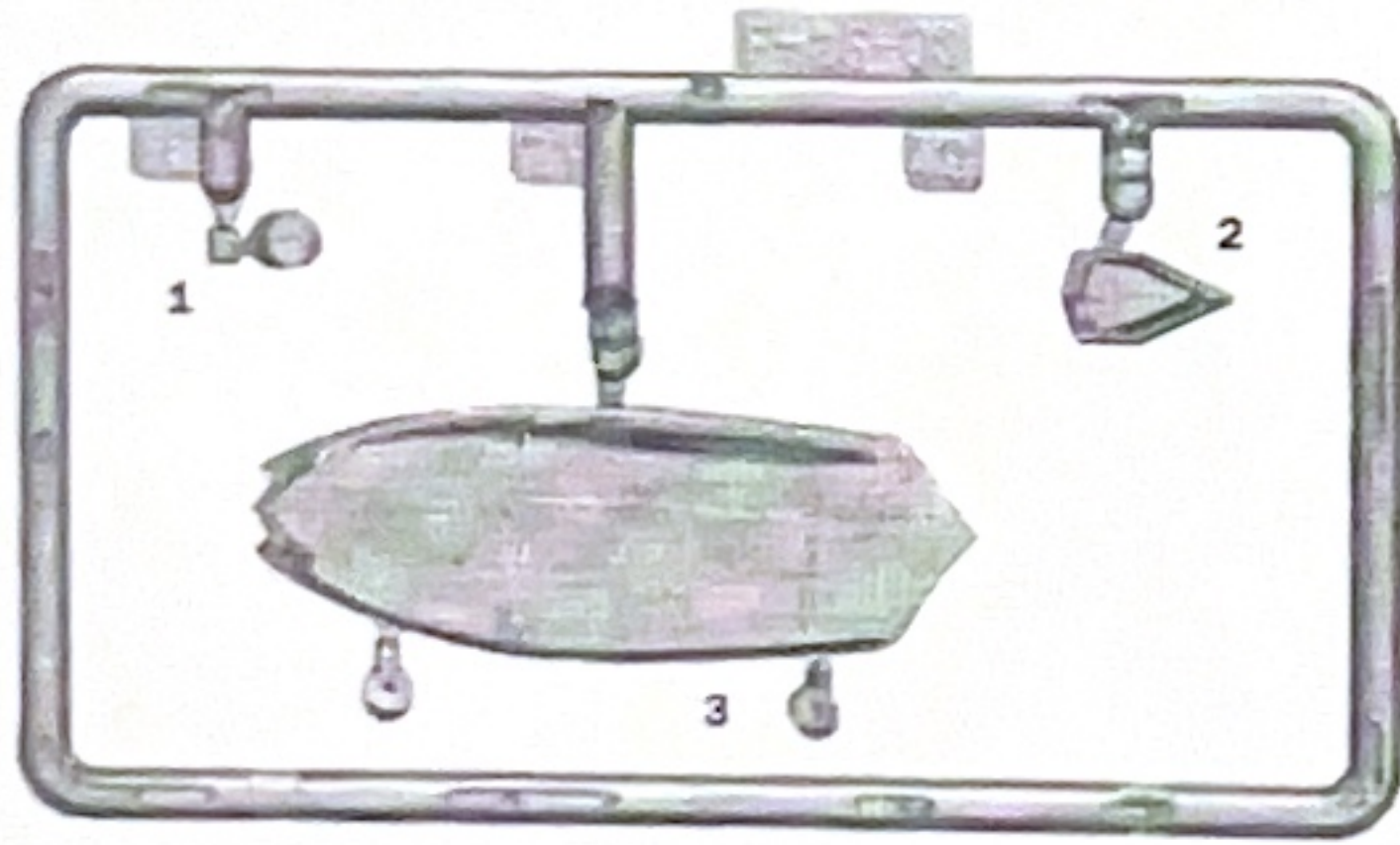
A**B****C**

Kesiniz

Ağırlık
Ekleyiniz

Deliniz

Boya Kod Rehberi

AGloss White
Parlak Beyaz
FS 17875**B**Flat Gun Metal
Mat Yanık Metal
FS 37200**C**Gloss Silver
Parlak Gümüş
FS 17178**D**Flat Black
Mat Siyah
FS 37038**E**Gloss Red
Parlak Kırmızı
FS 11302**F**Flat Light Ghost Gray
Mat Açık Gri
FS 36300**G**Flat Dark Green
Mat Koyu Yeşil
FS 34079**H**Gloss Green
Parlak Yeşil
FS 14090

ADIM 1

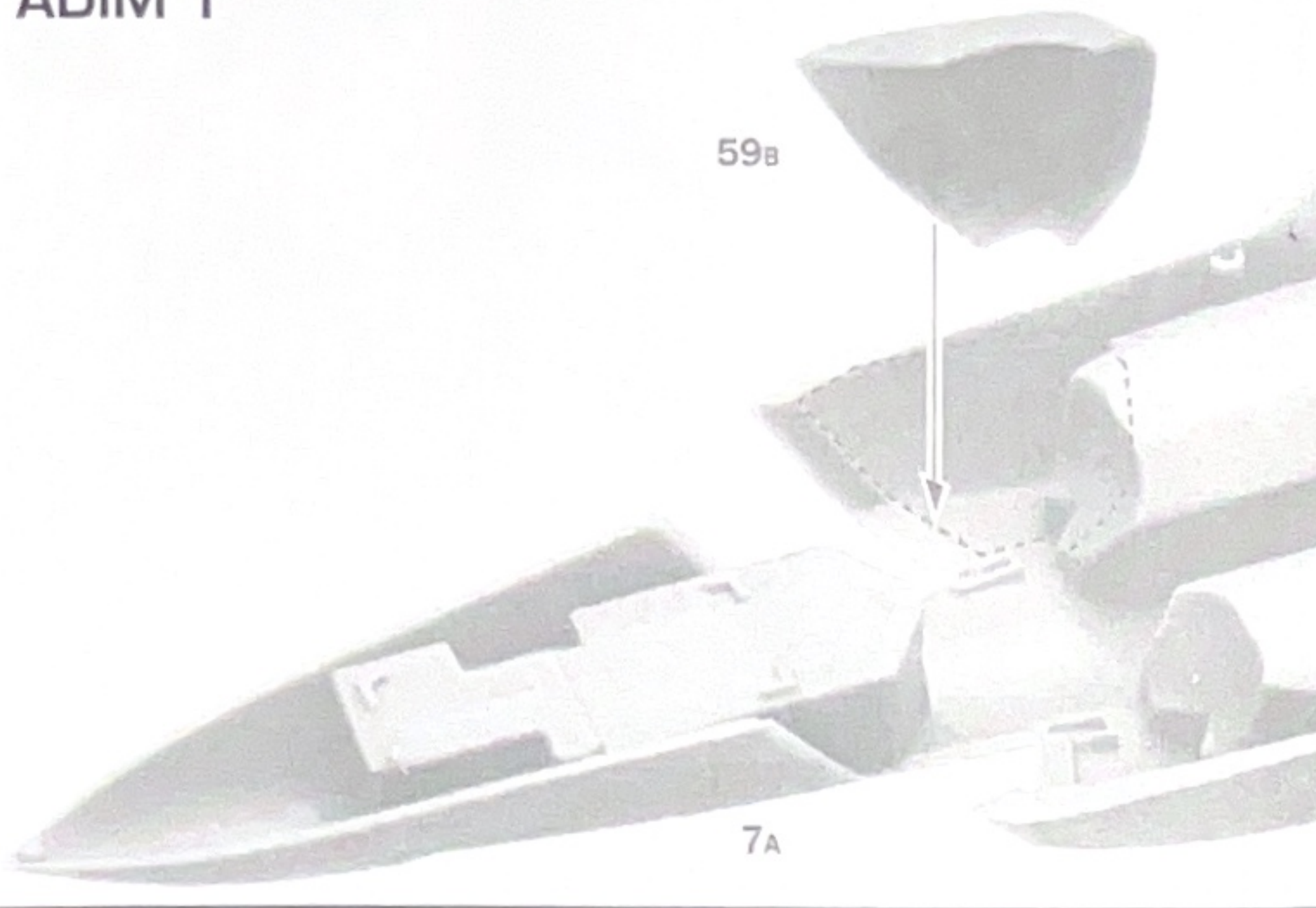

ADIM 2

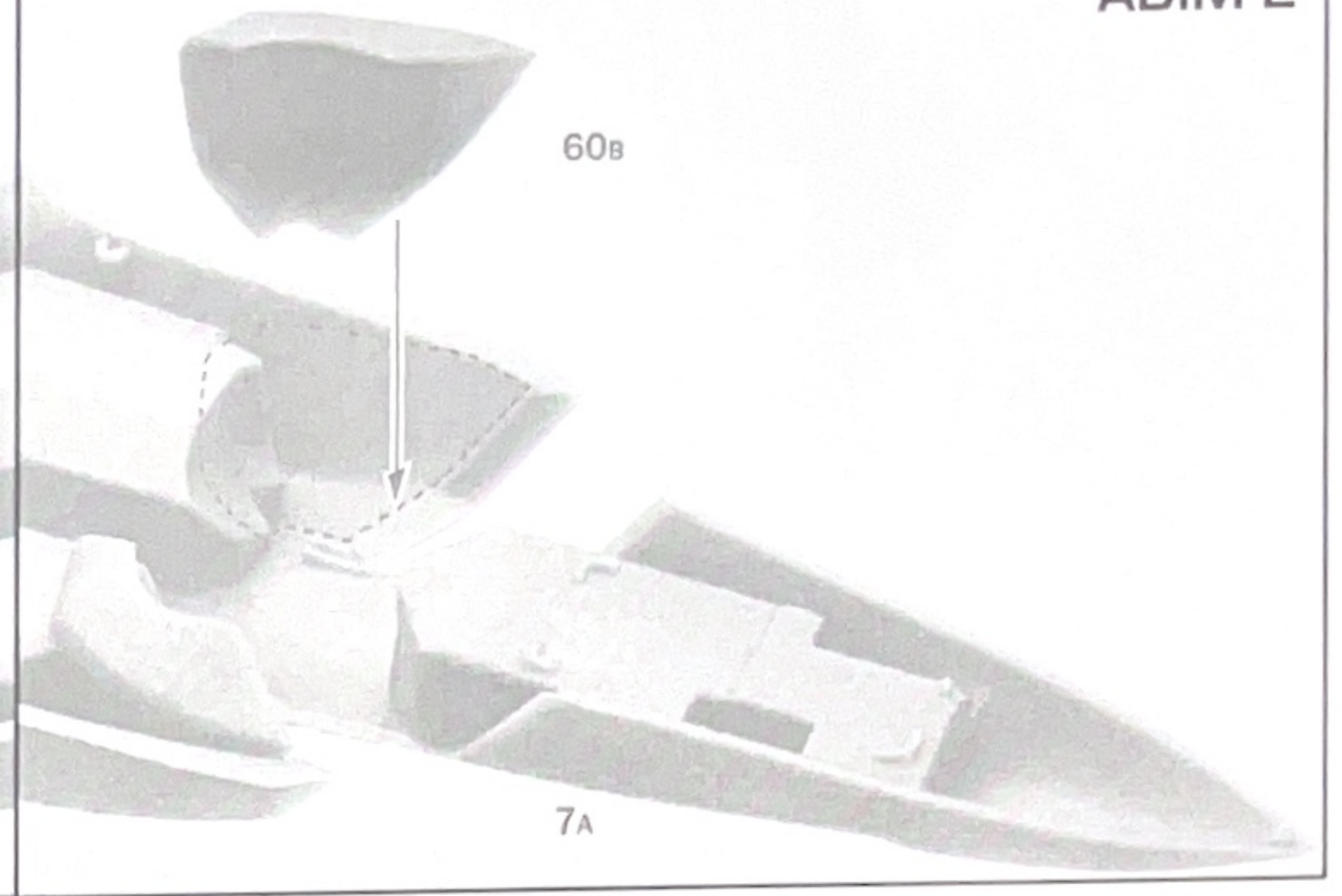

ADIM 3

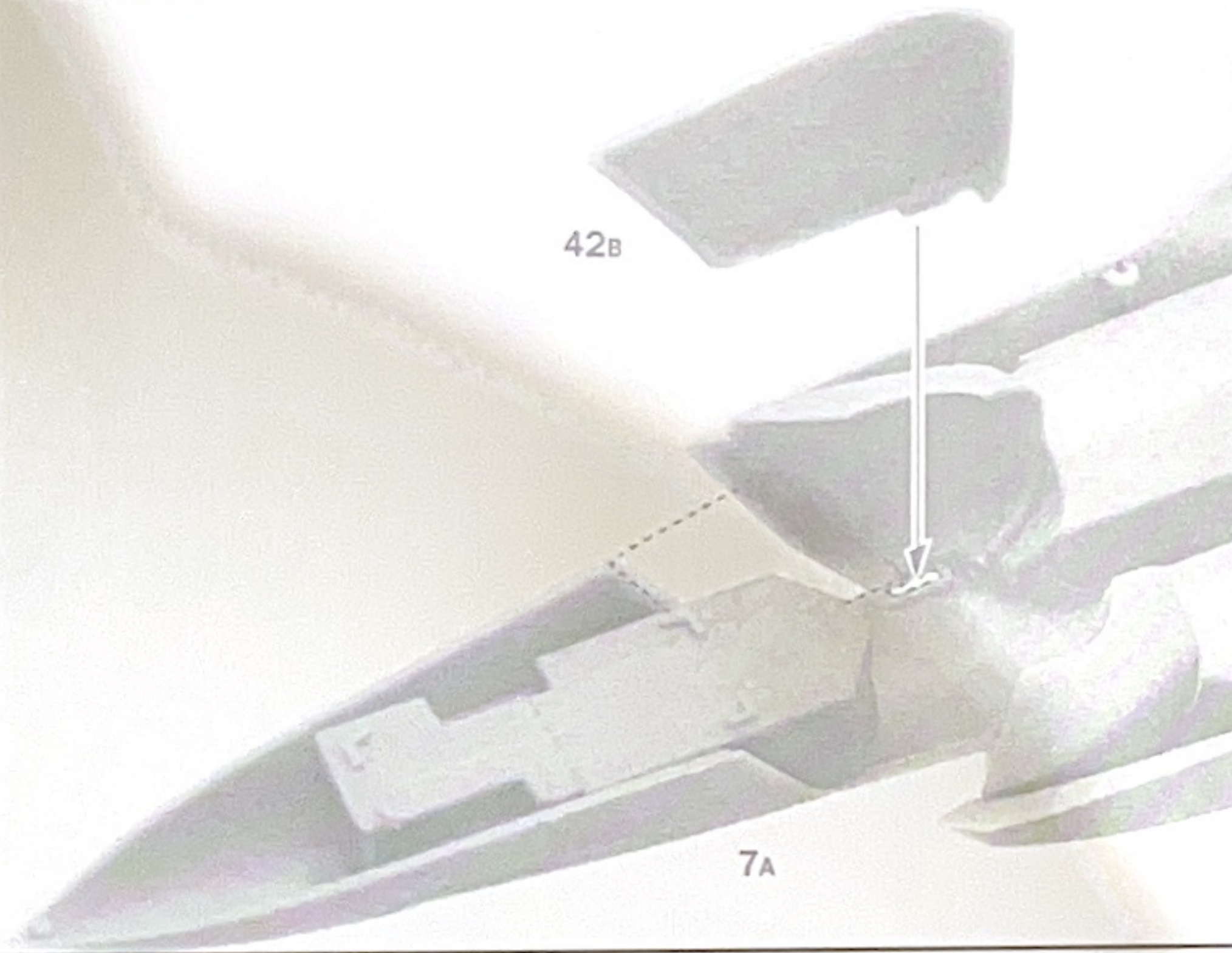

ADIM 4

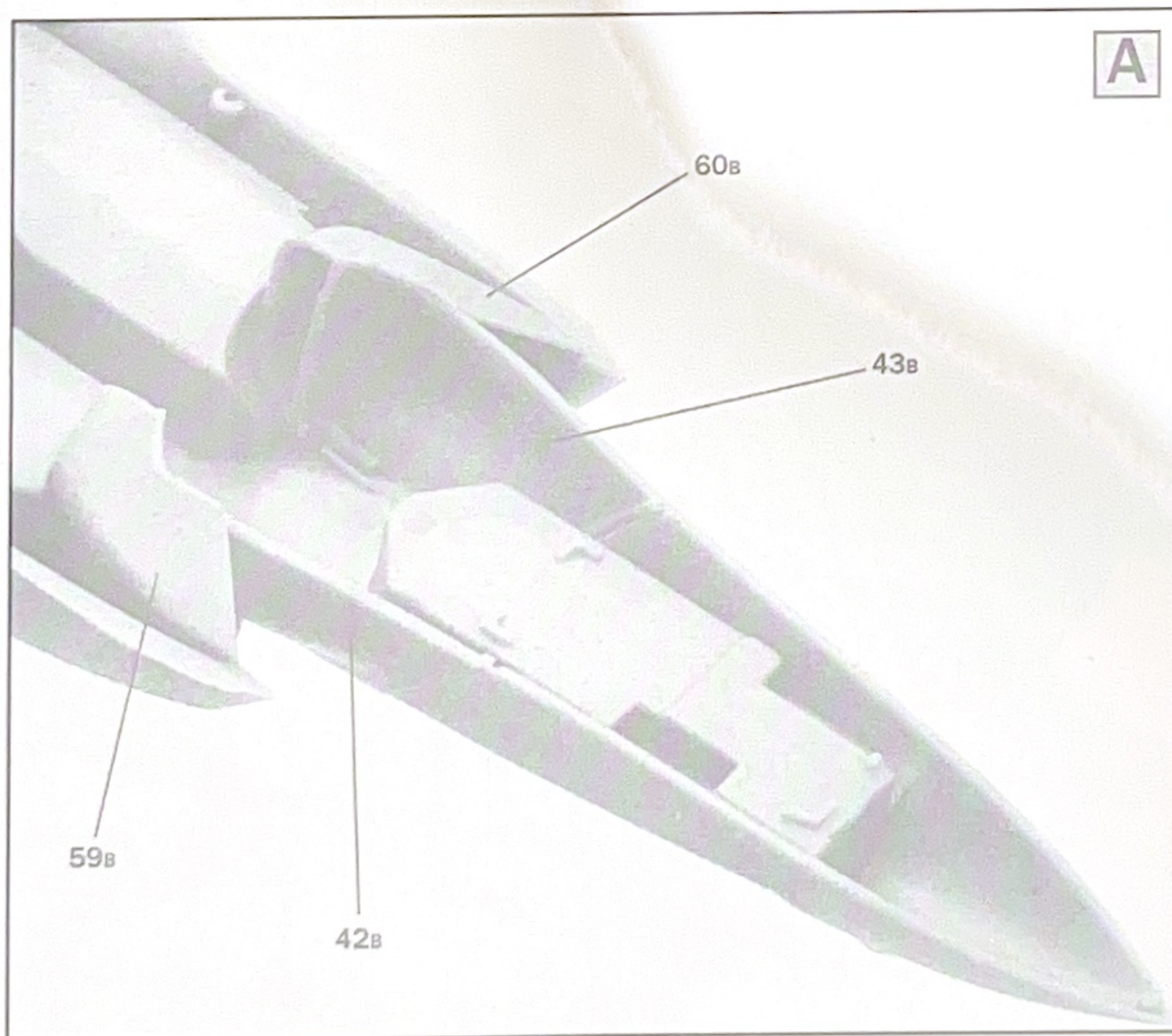
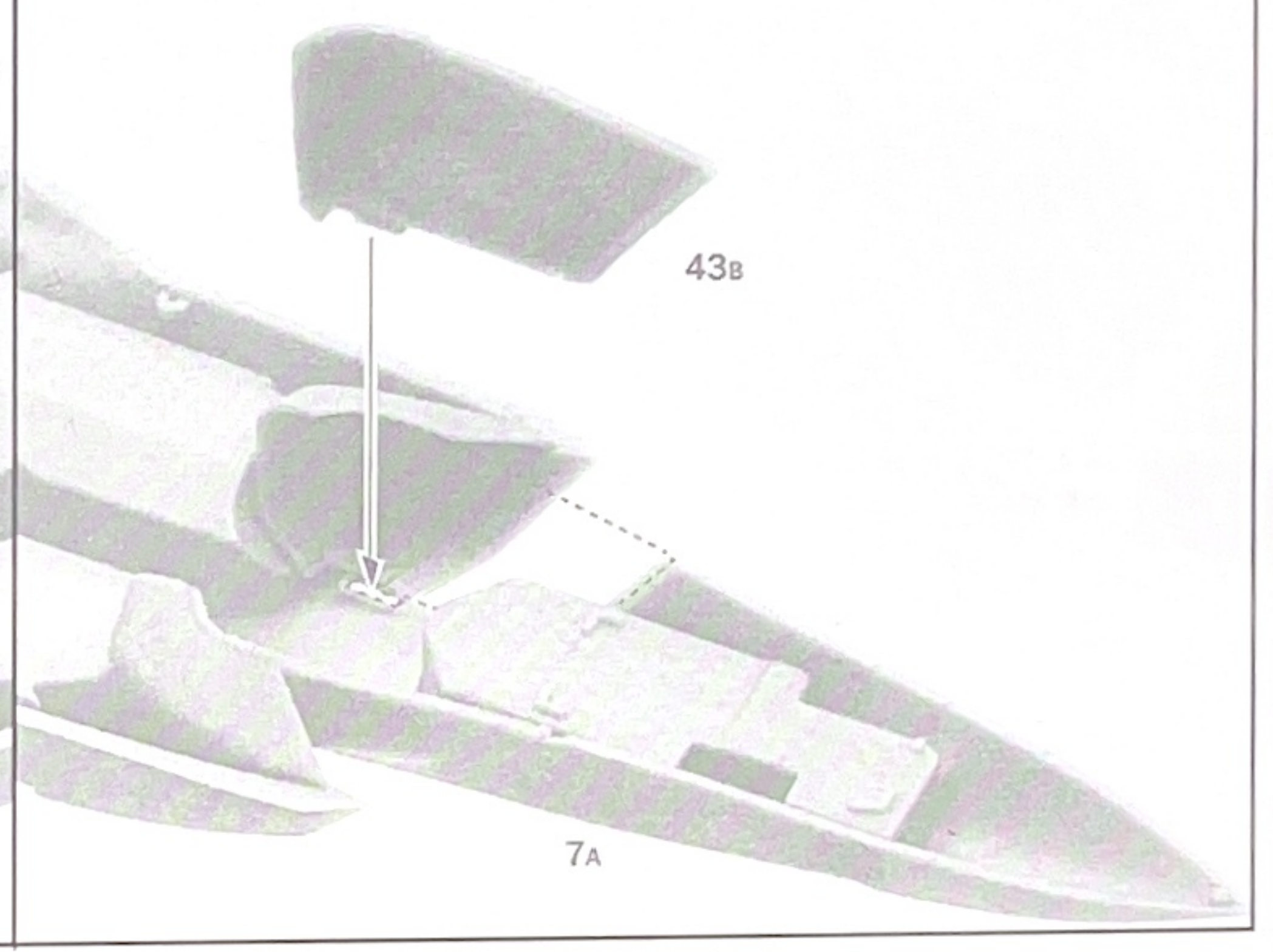

2

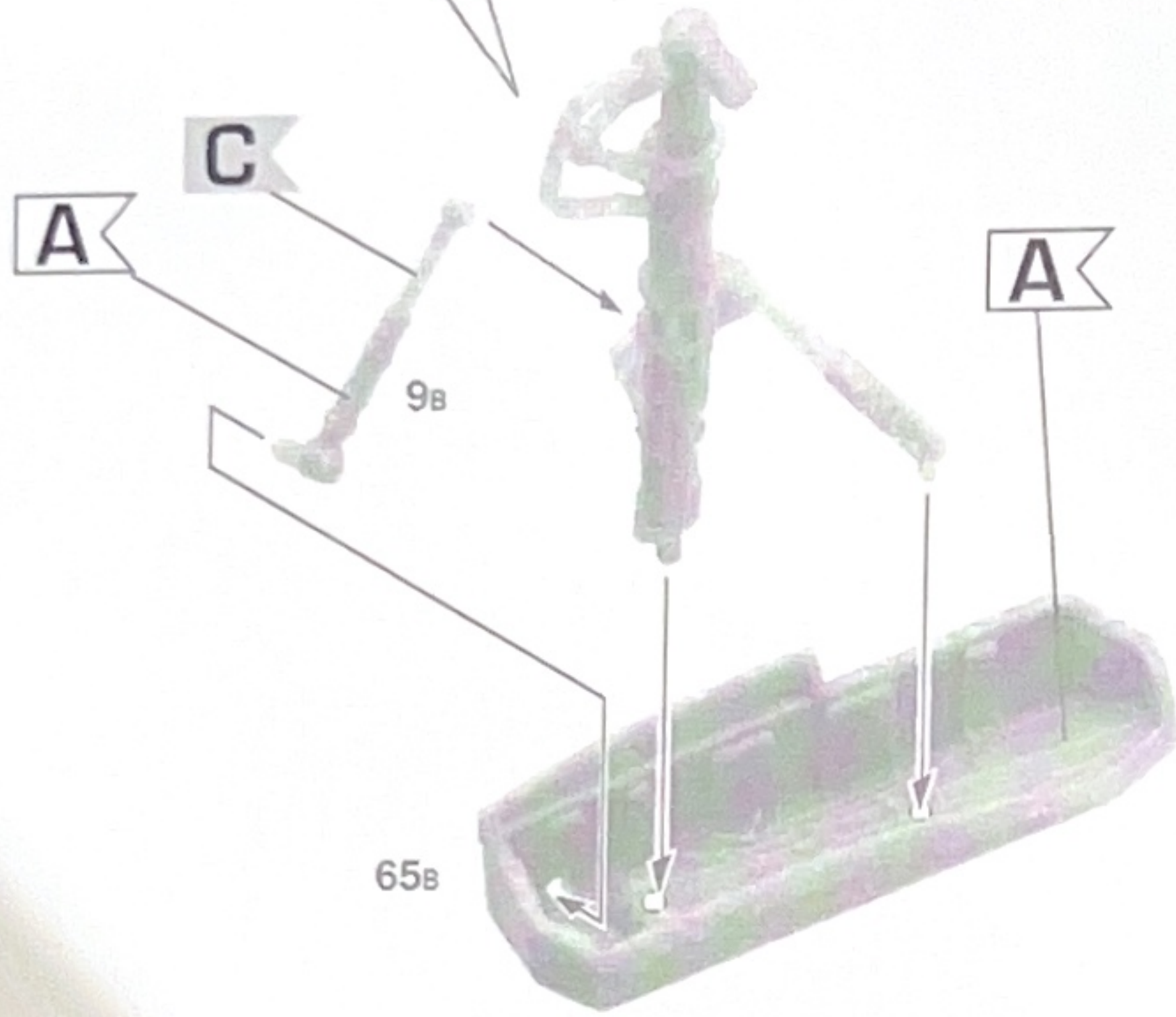
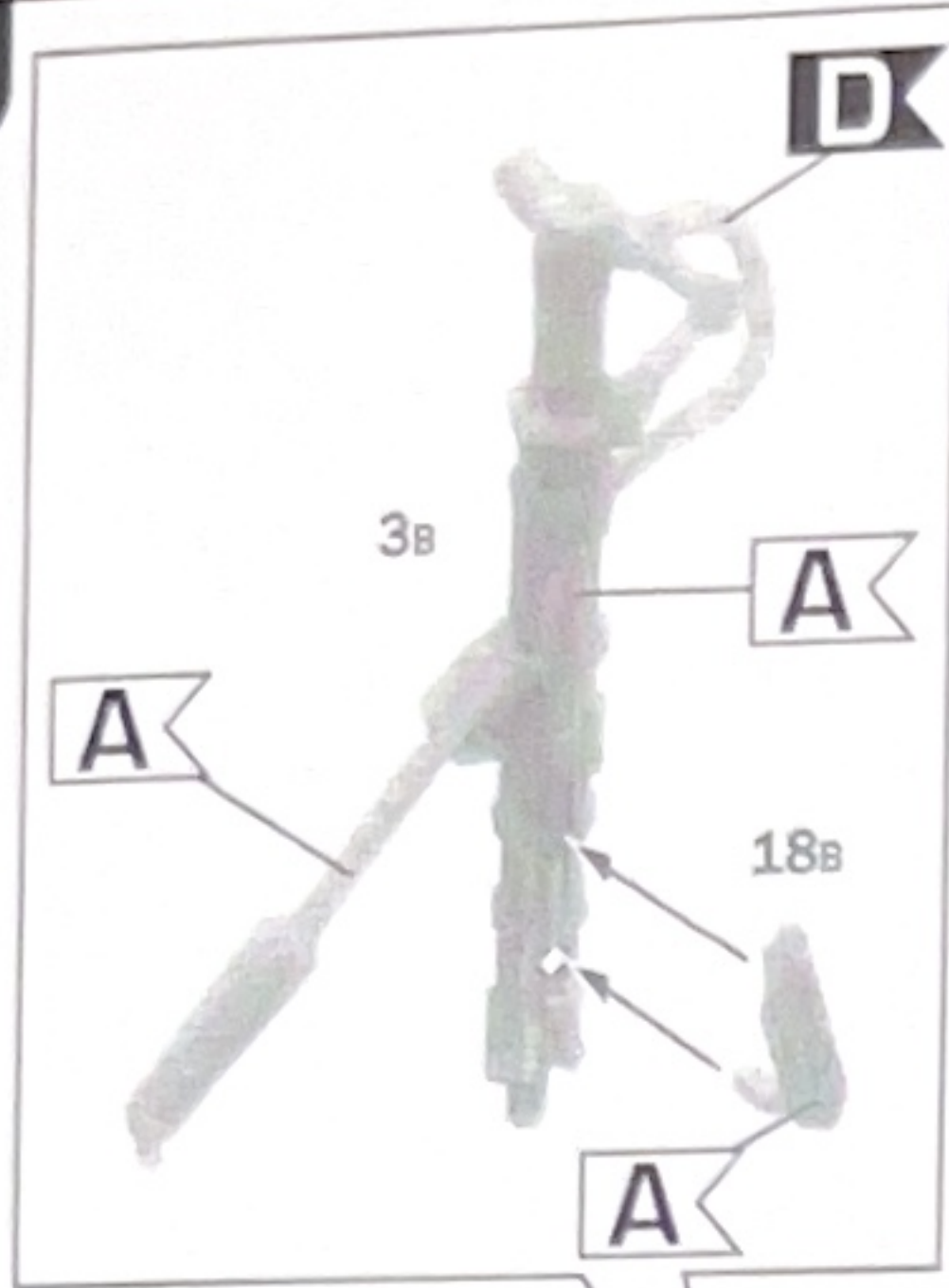

B

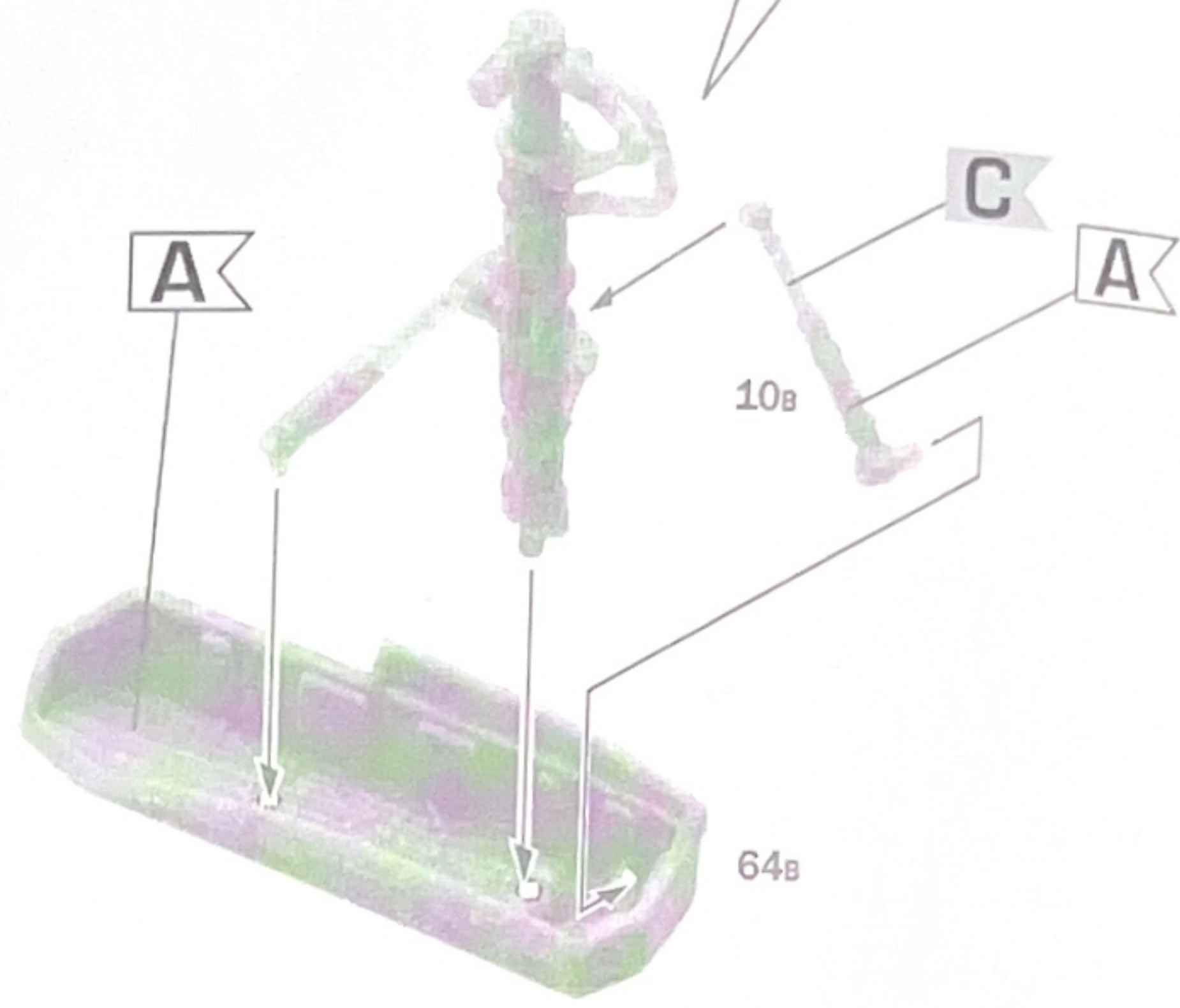
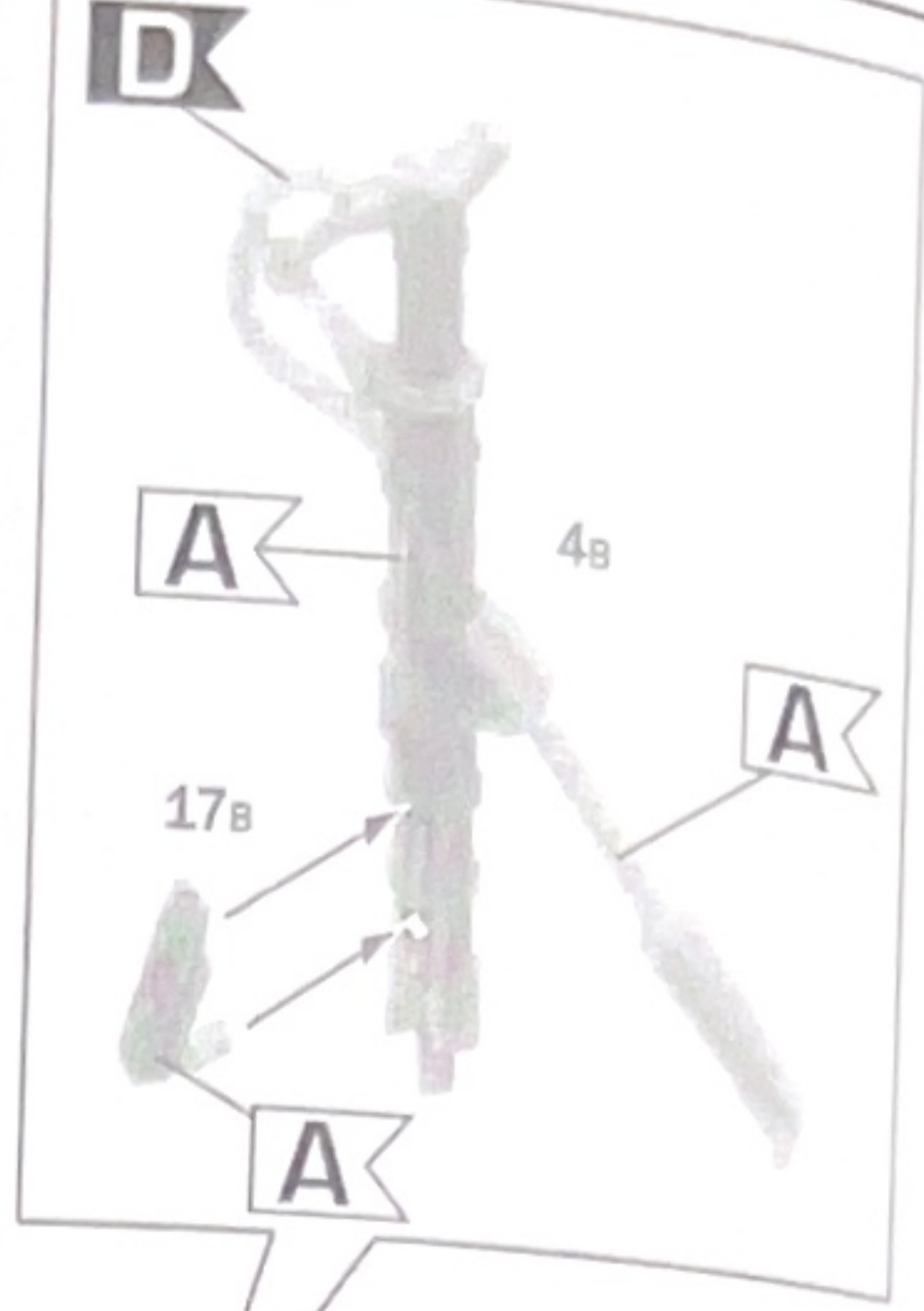

3

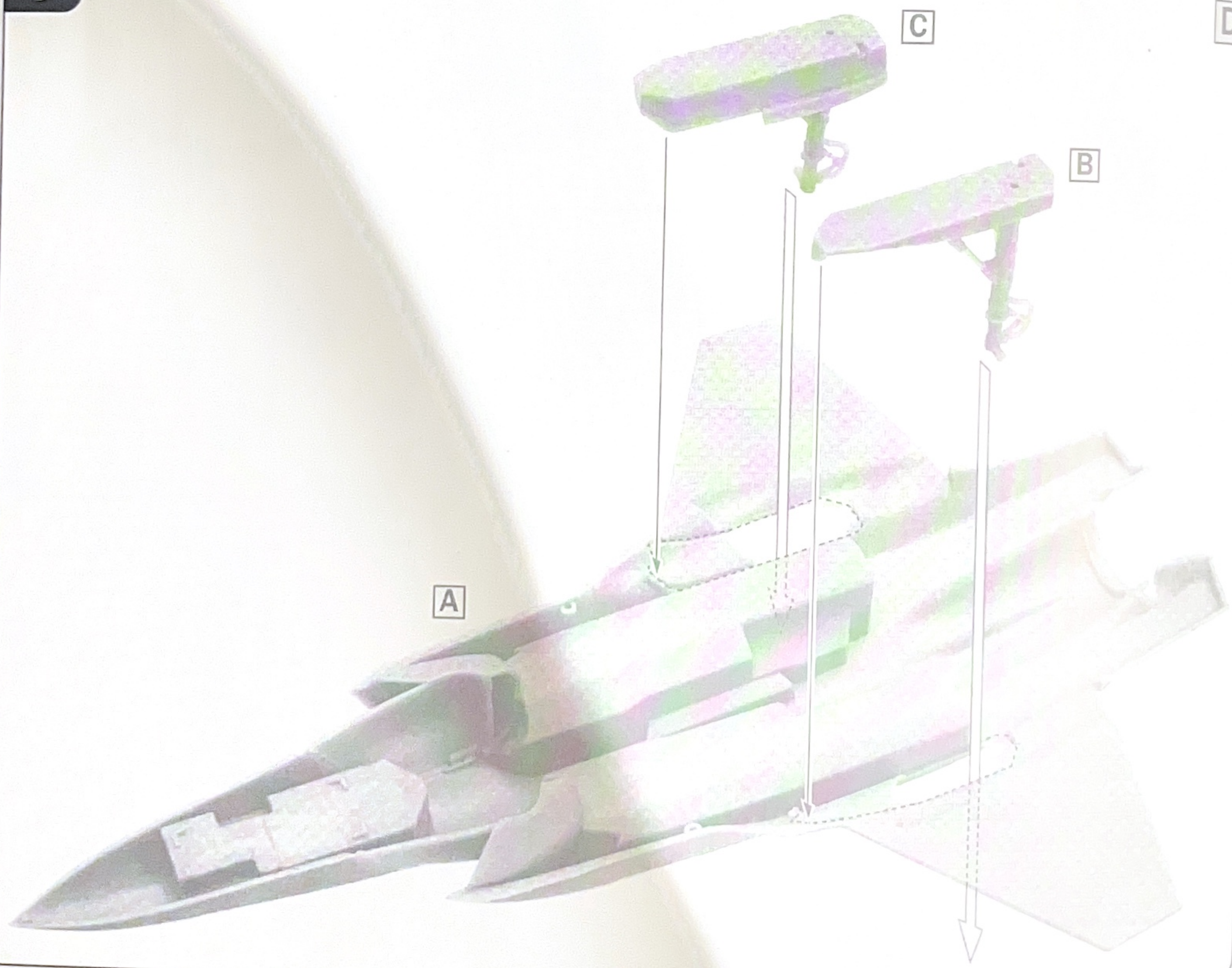

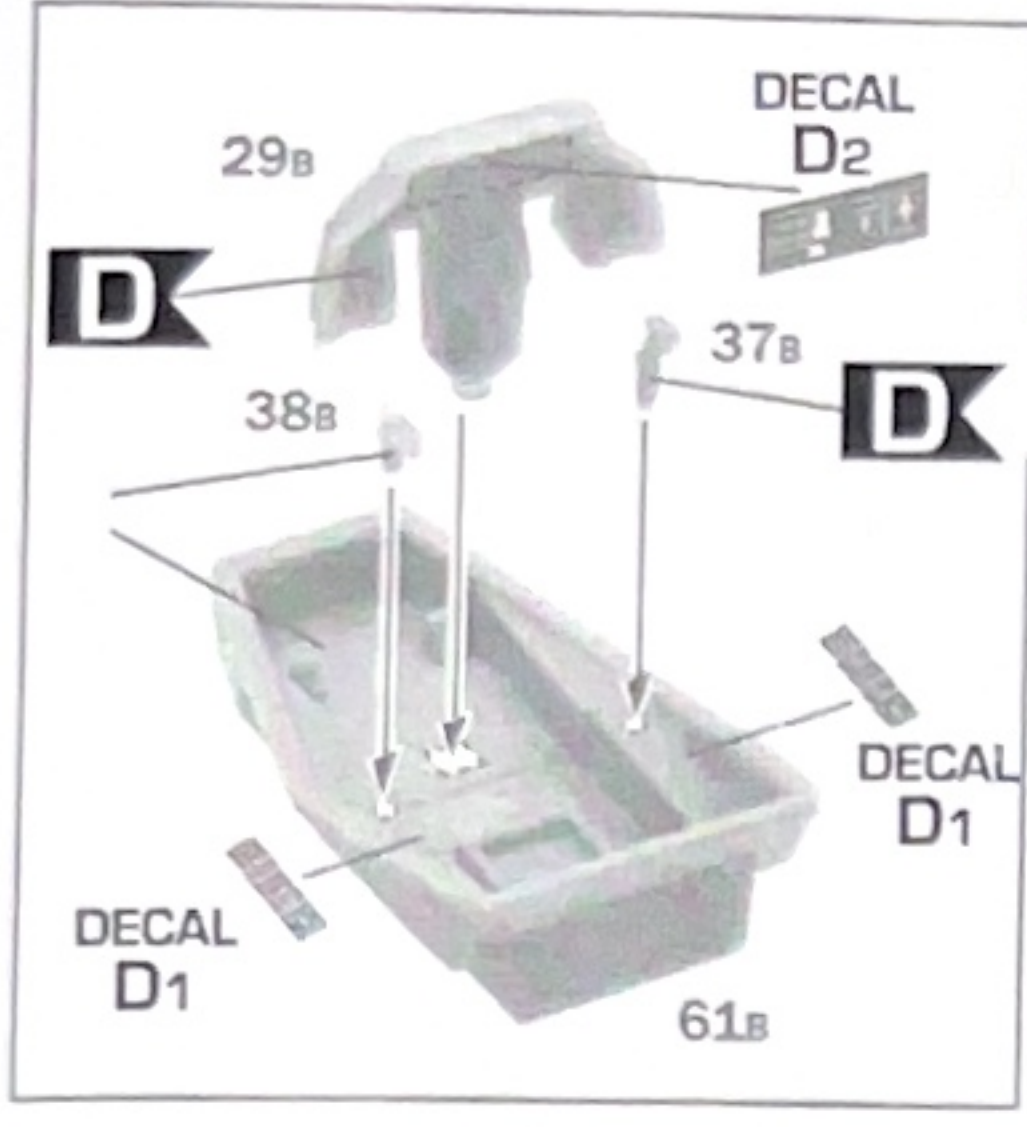

PARÇA NO: 26B
SADECE KANOPI AÇIK
YAPILACAK İSE KULLANIN

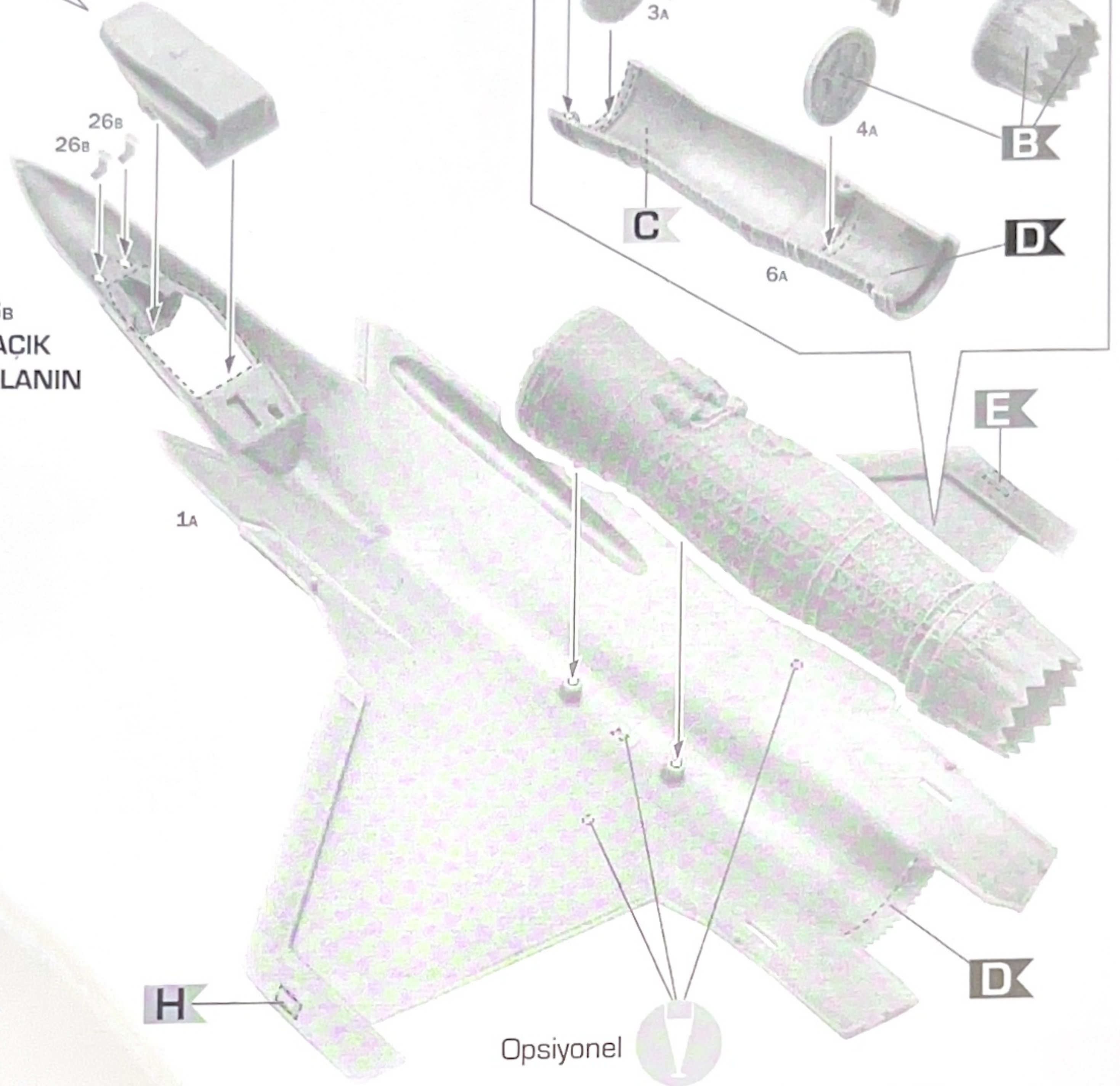

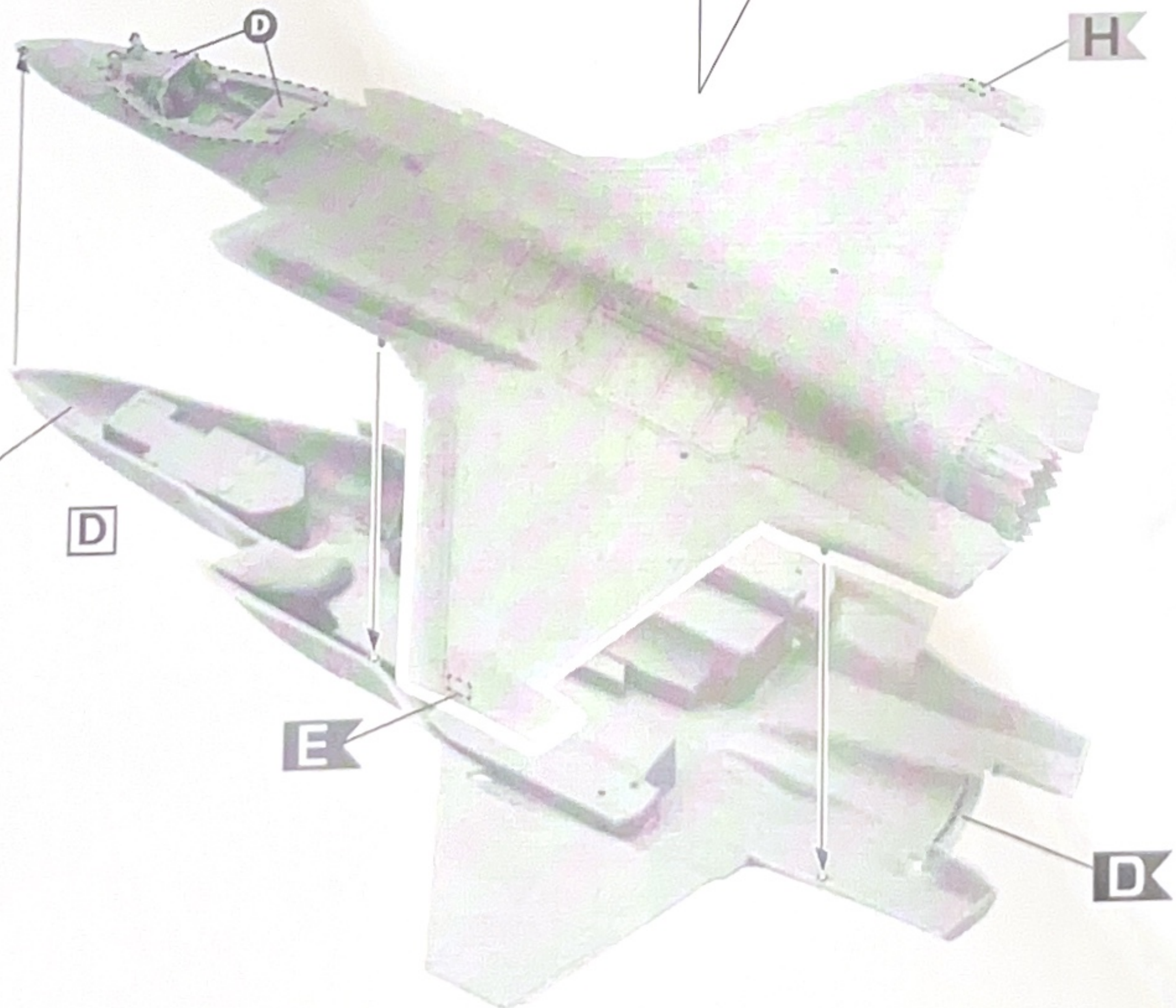

Ağırlık
Ekleyiniz

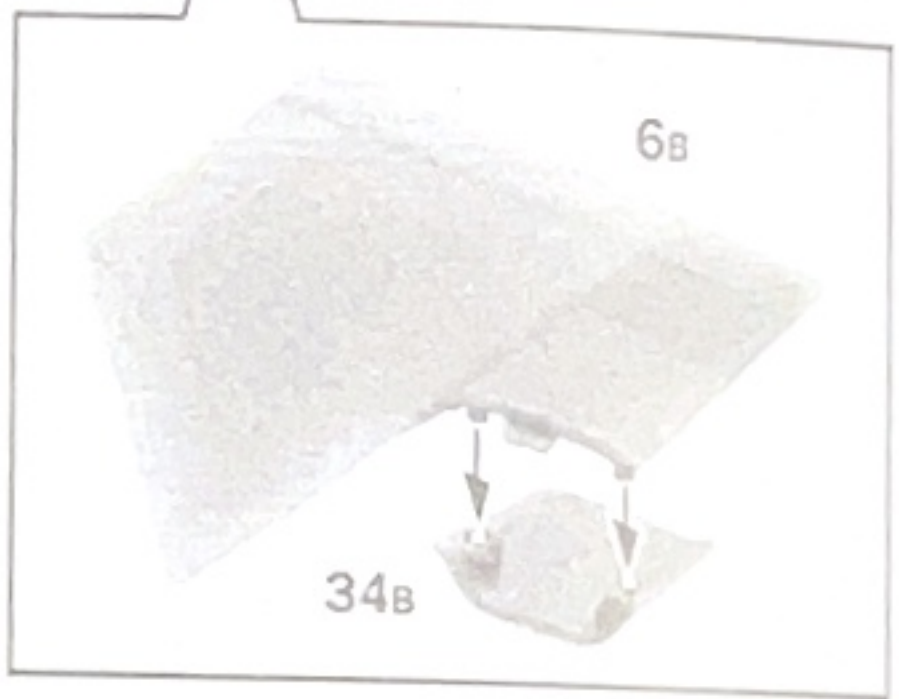
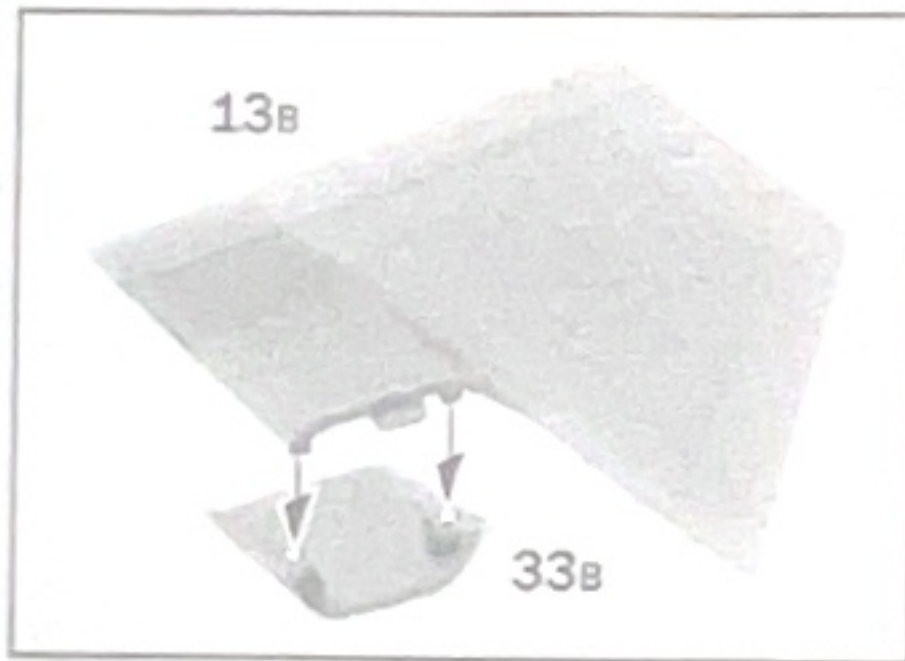
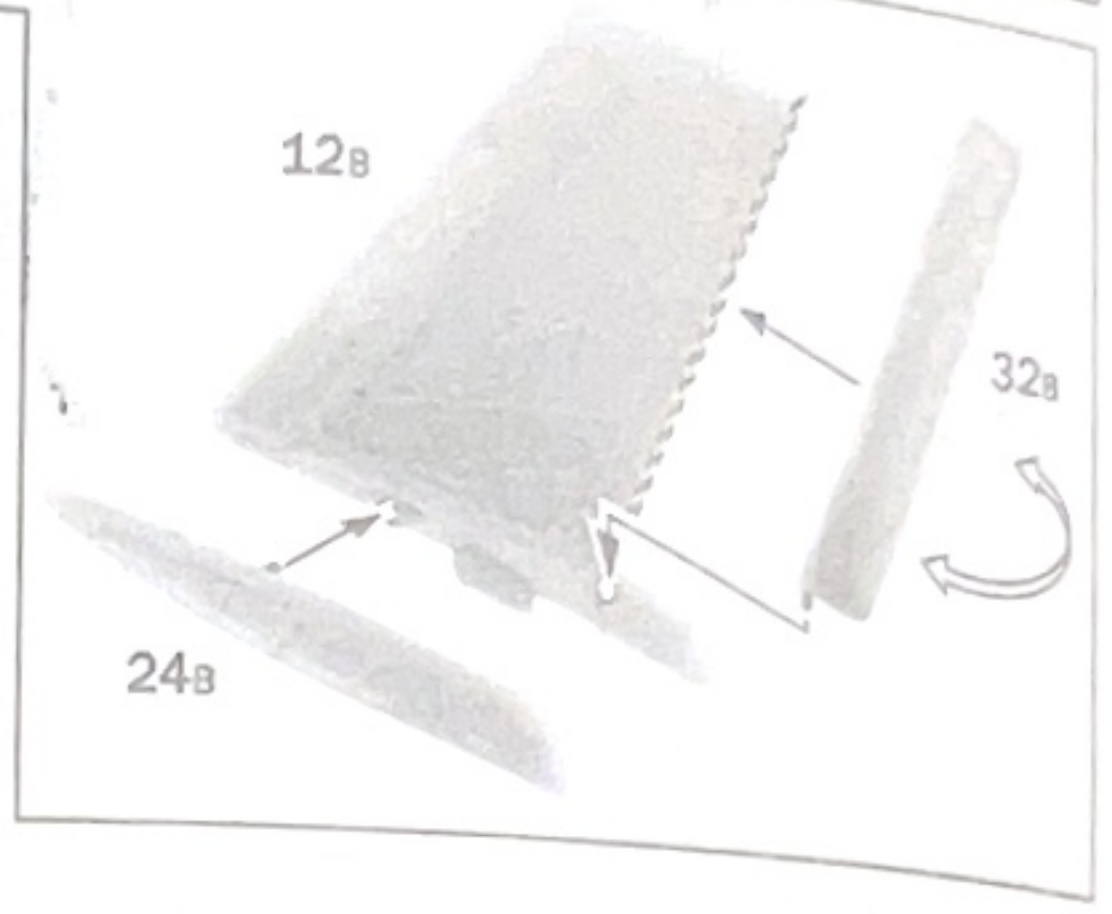
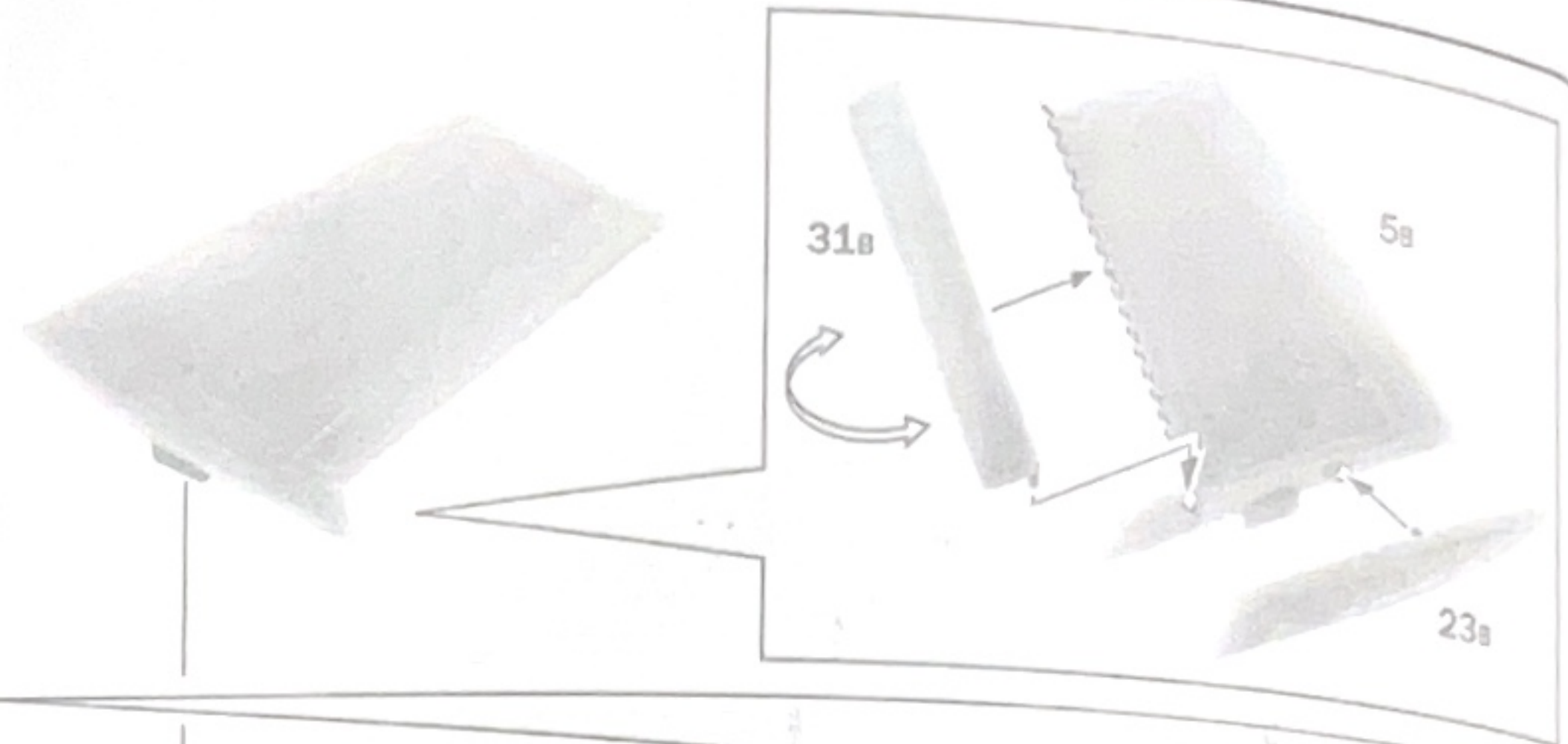
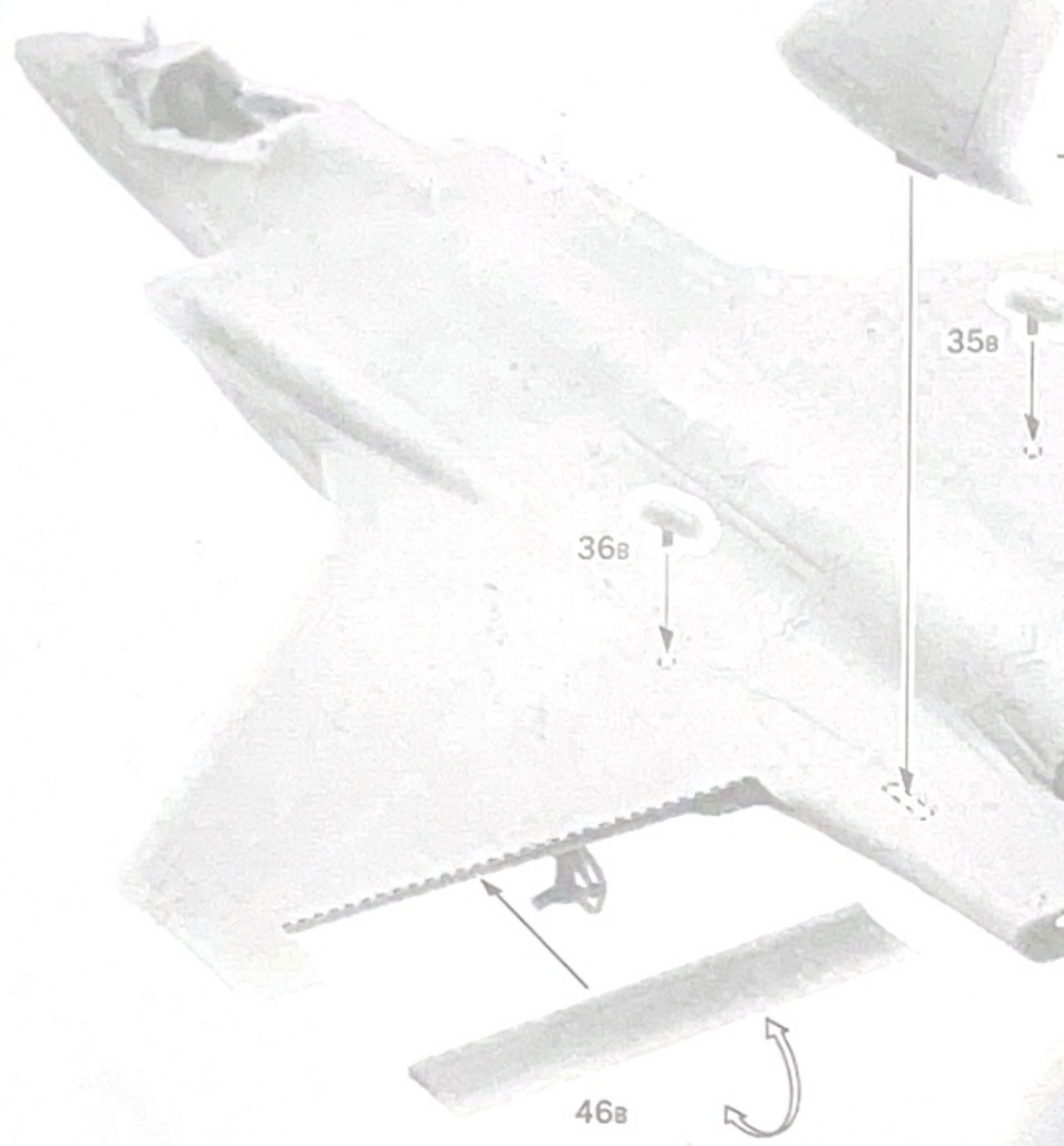

5

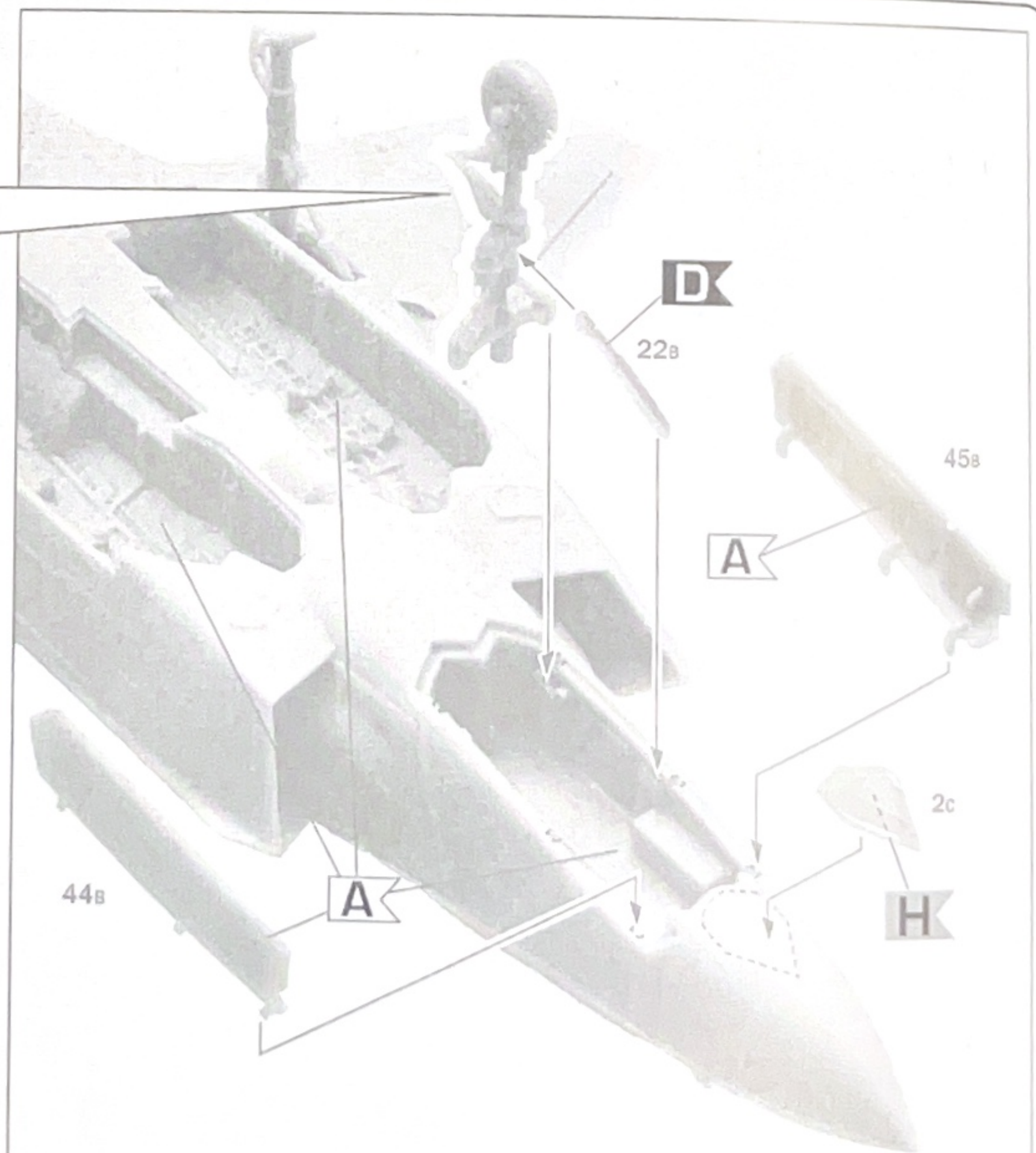
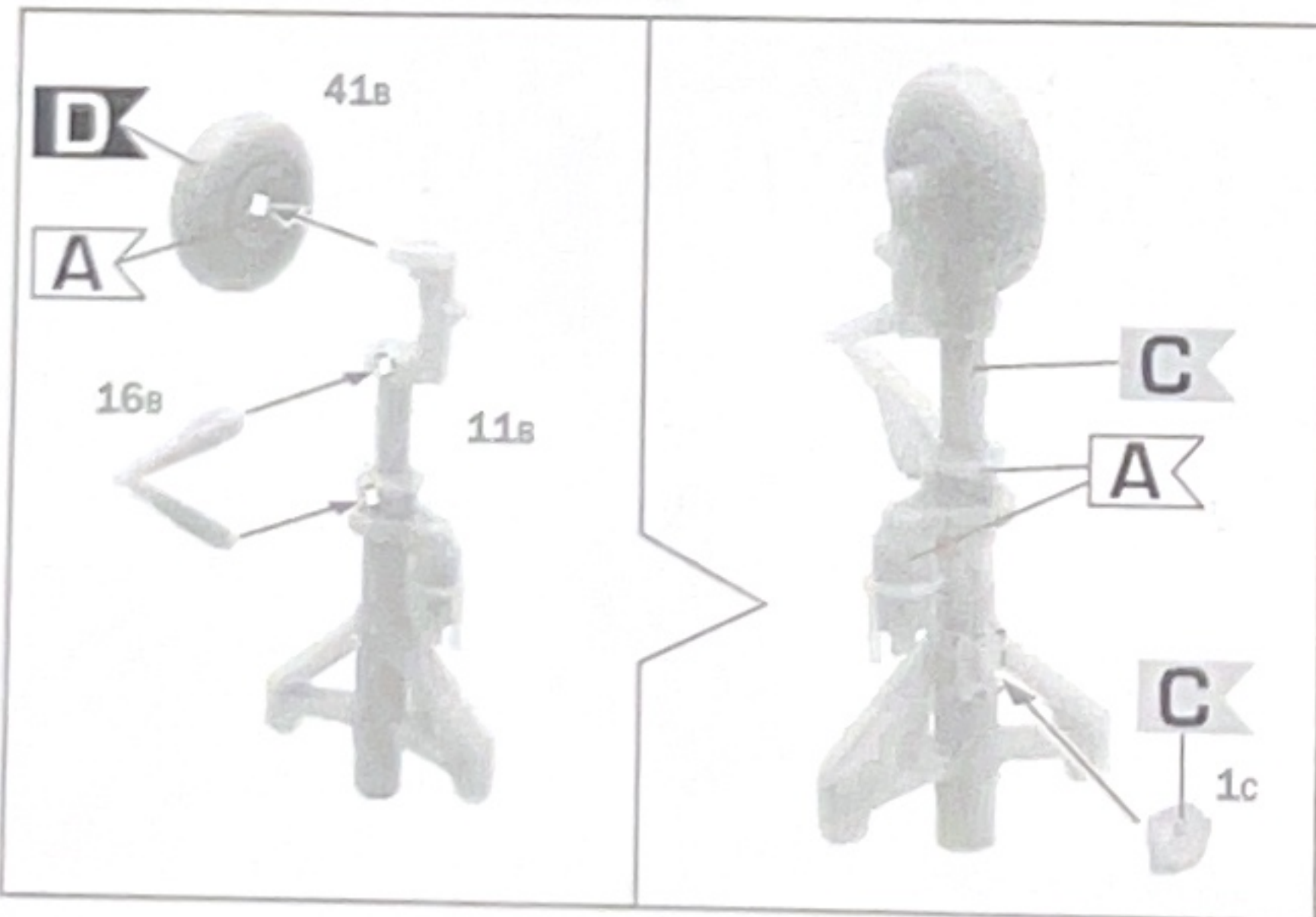

6



6

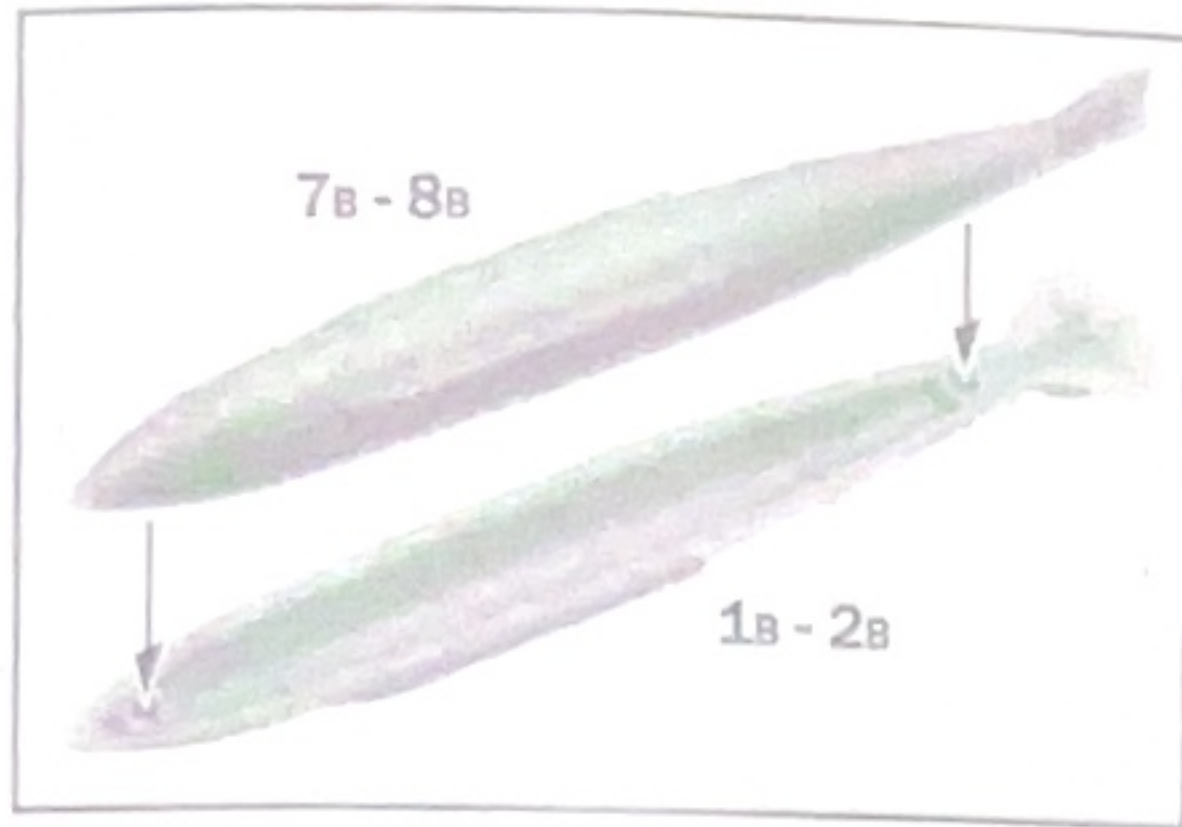

GBU-31 DECAL

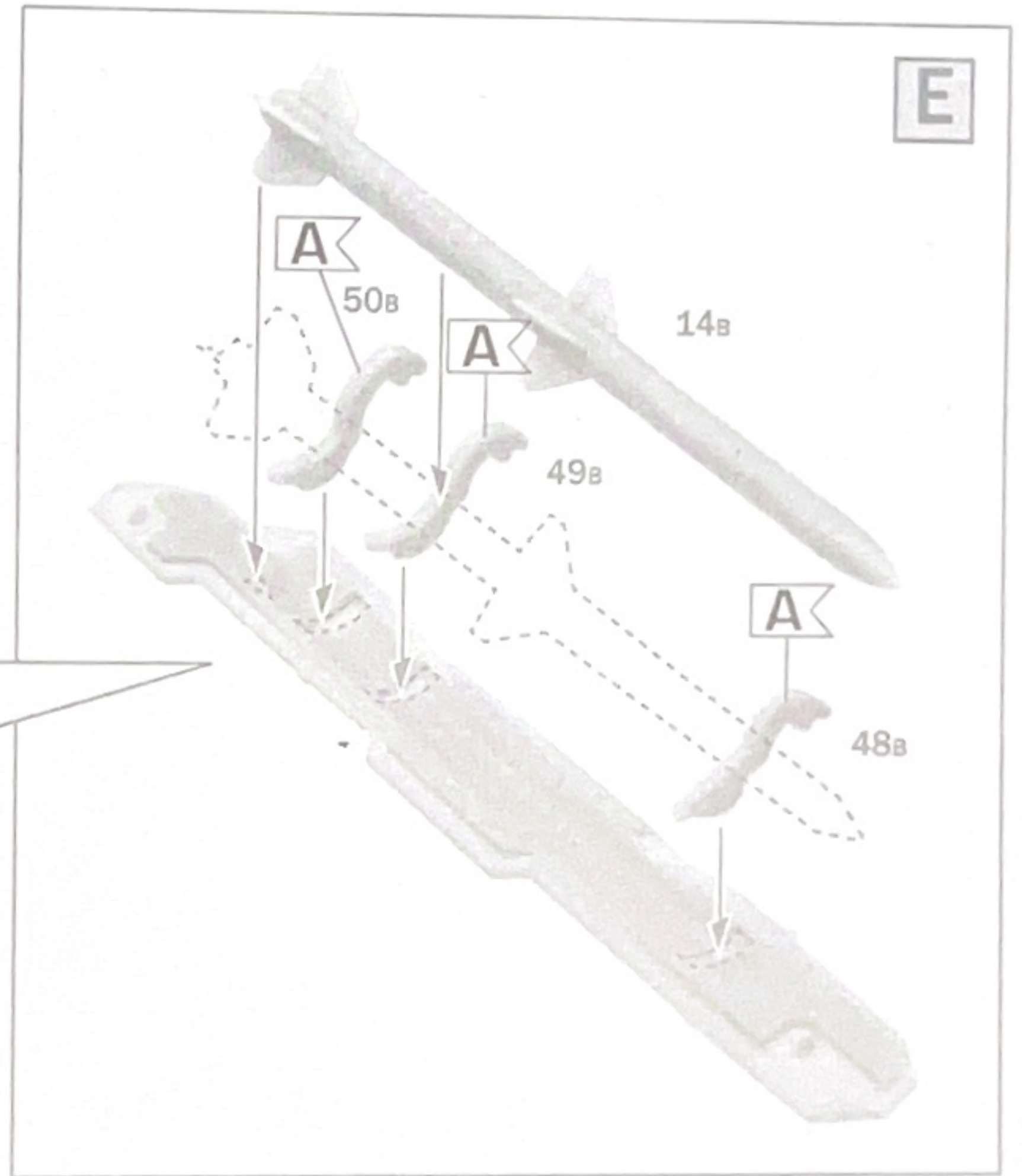
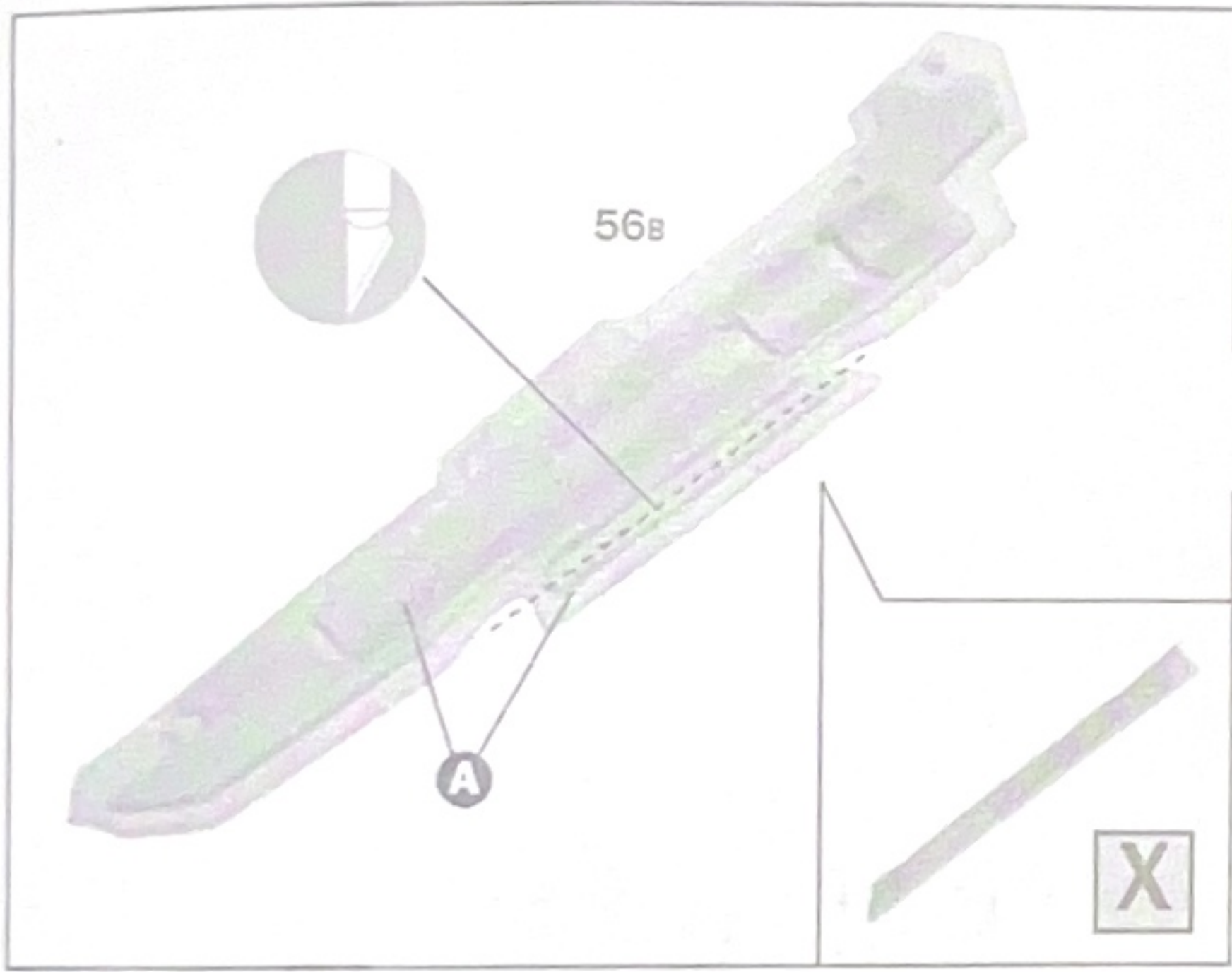
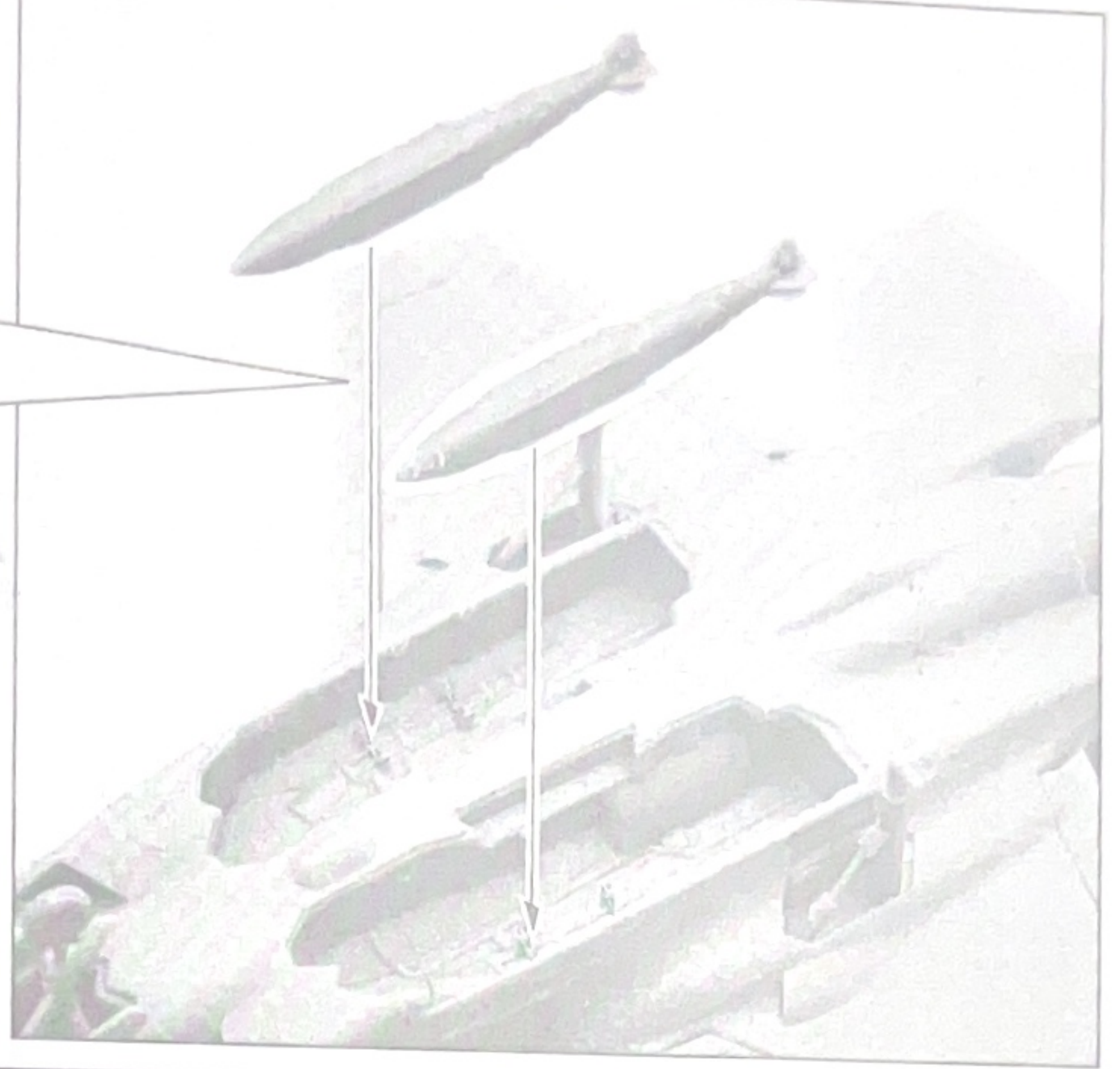
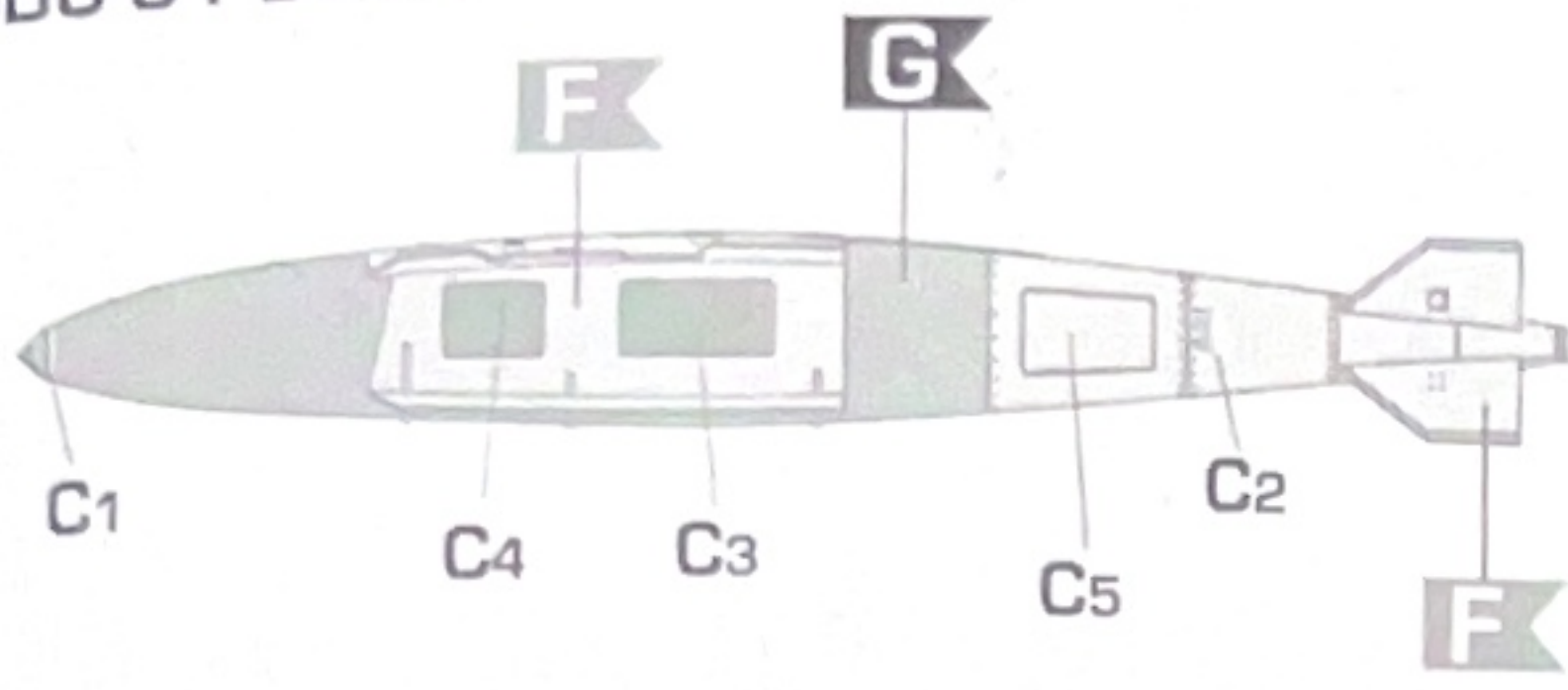

AIM-120 DECAL

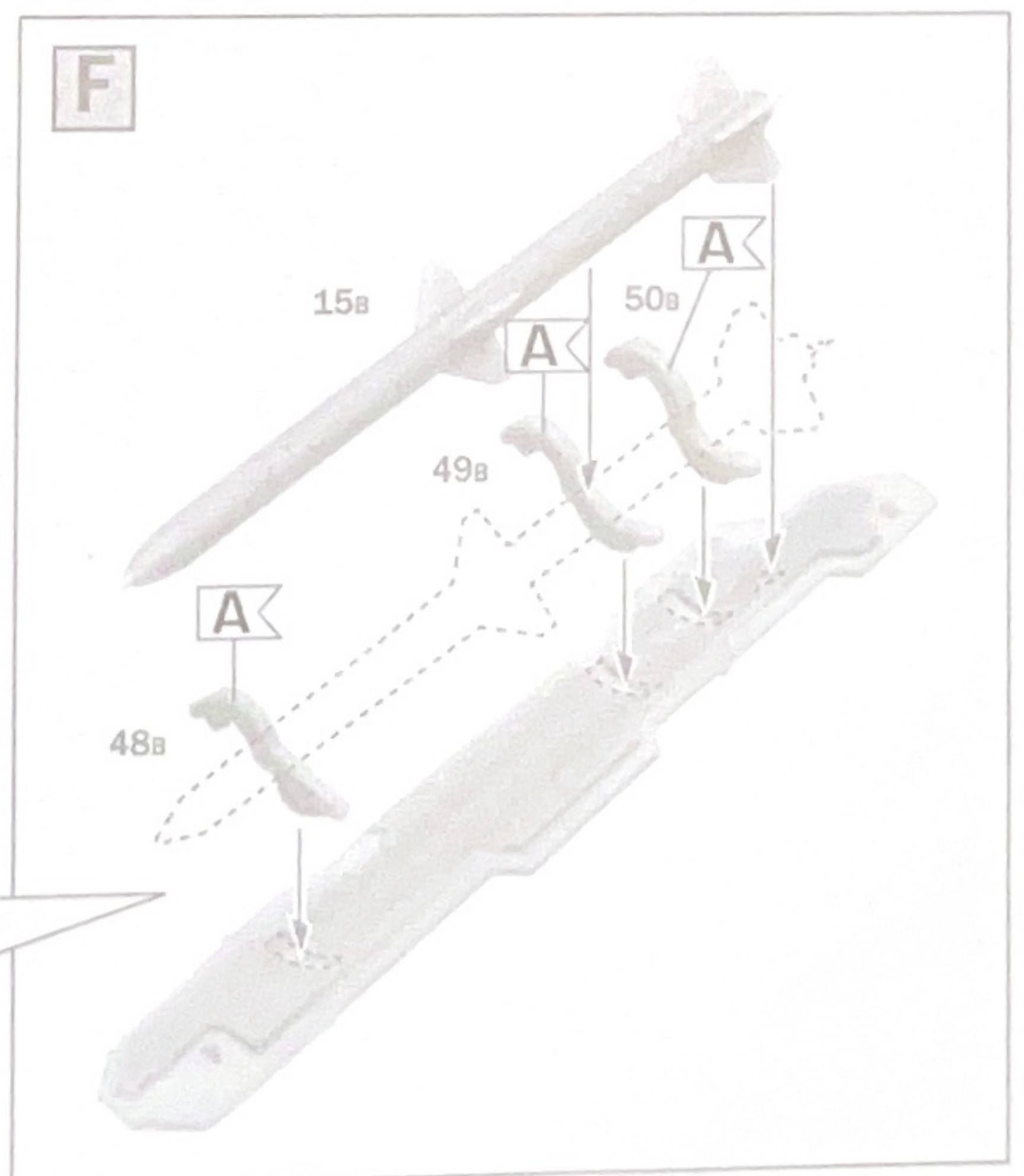
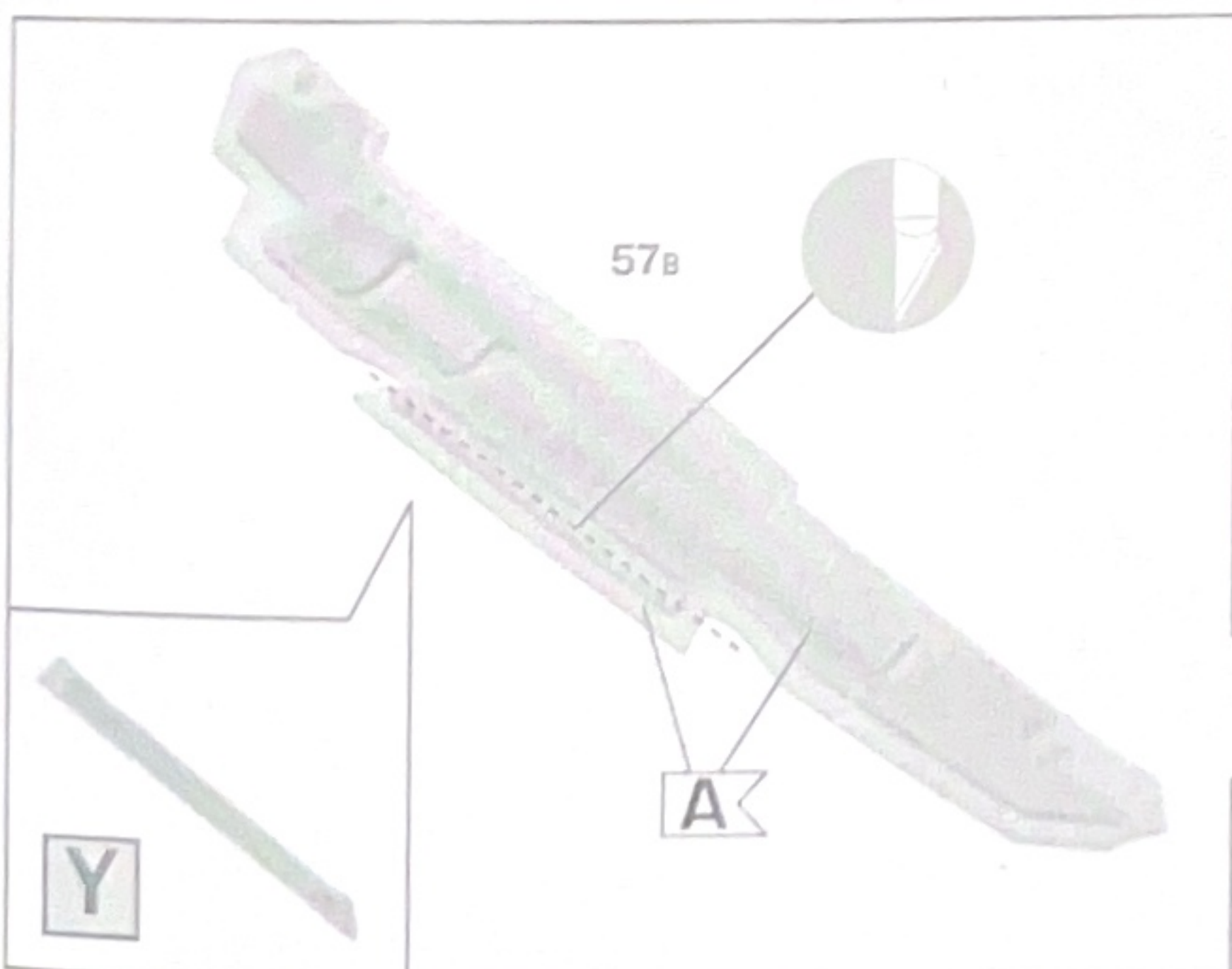
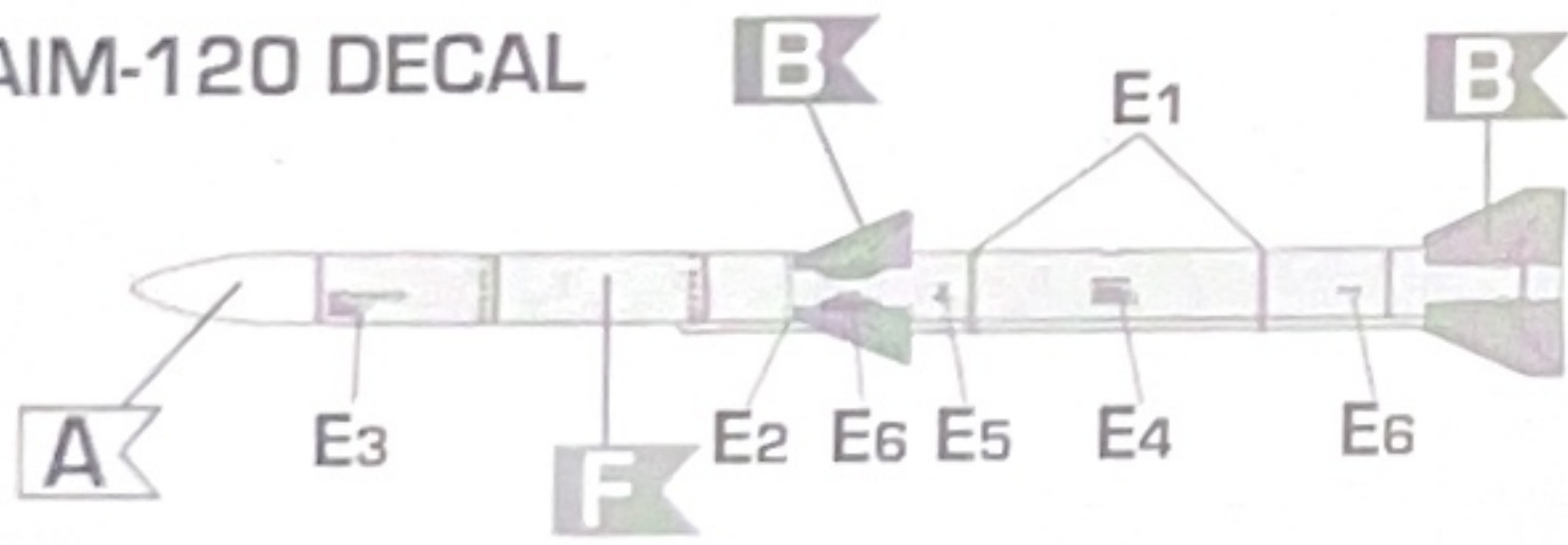

9

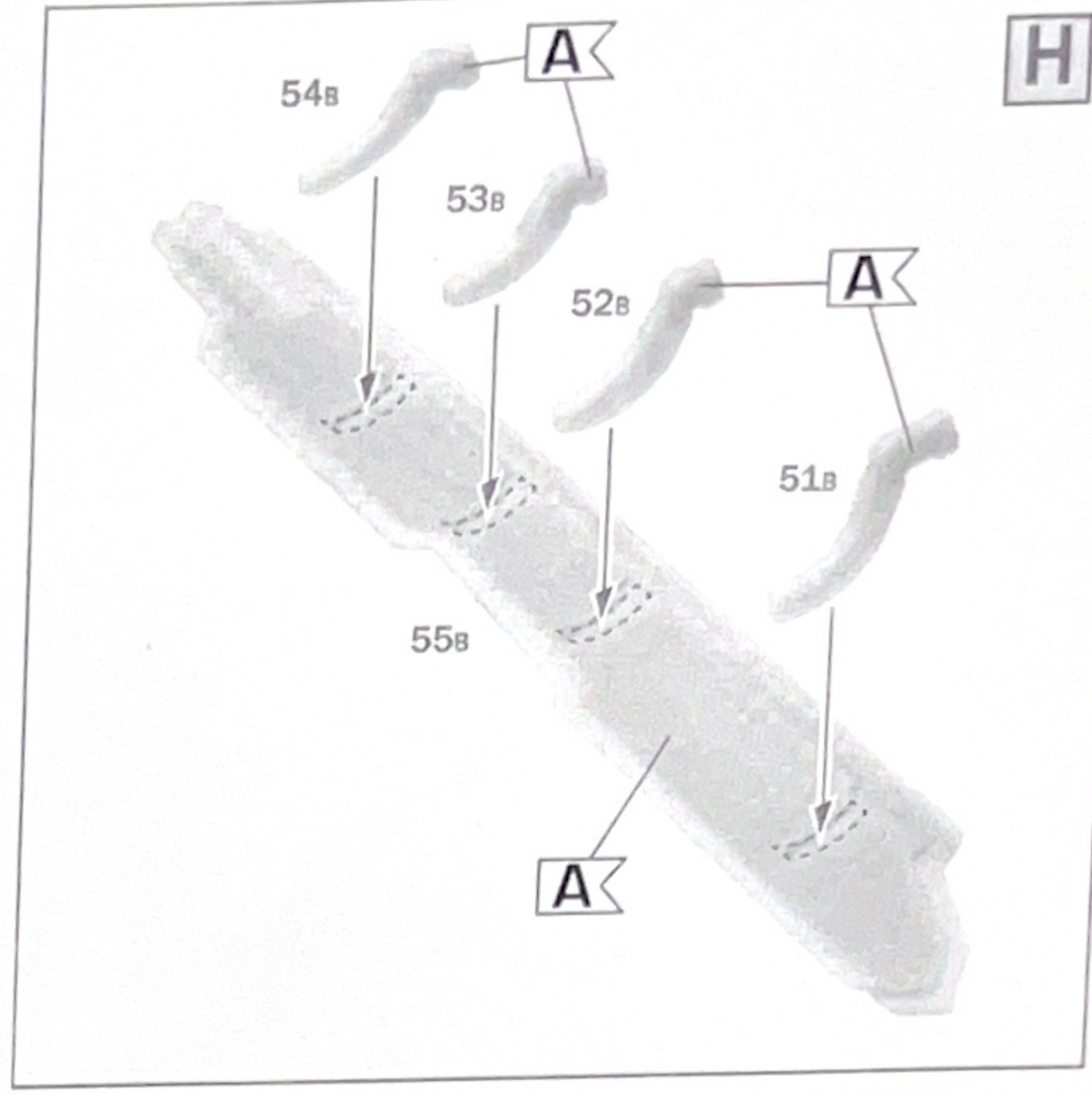
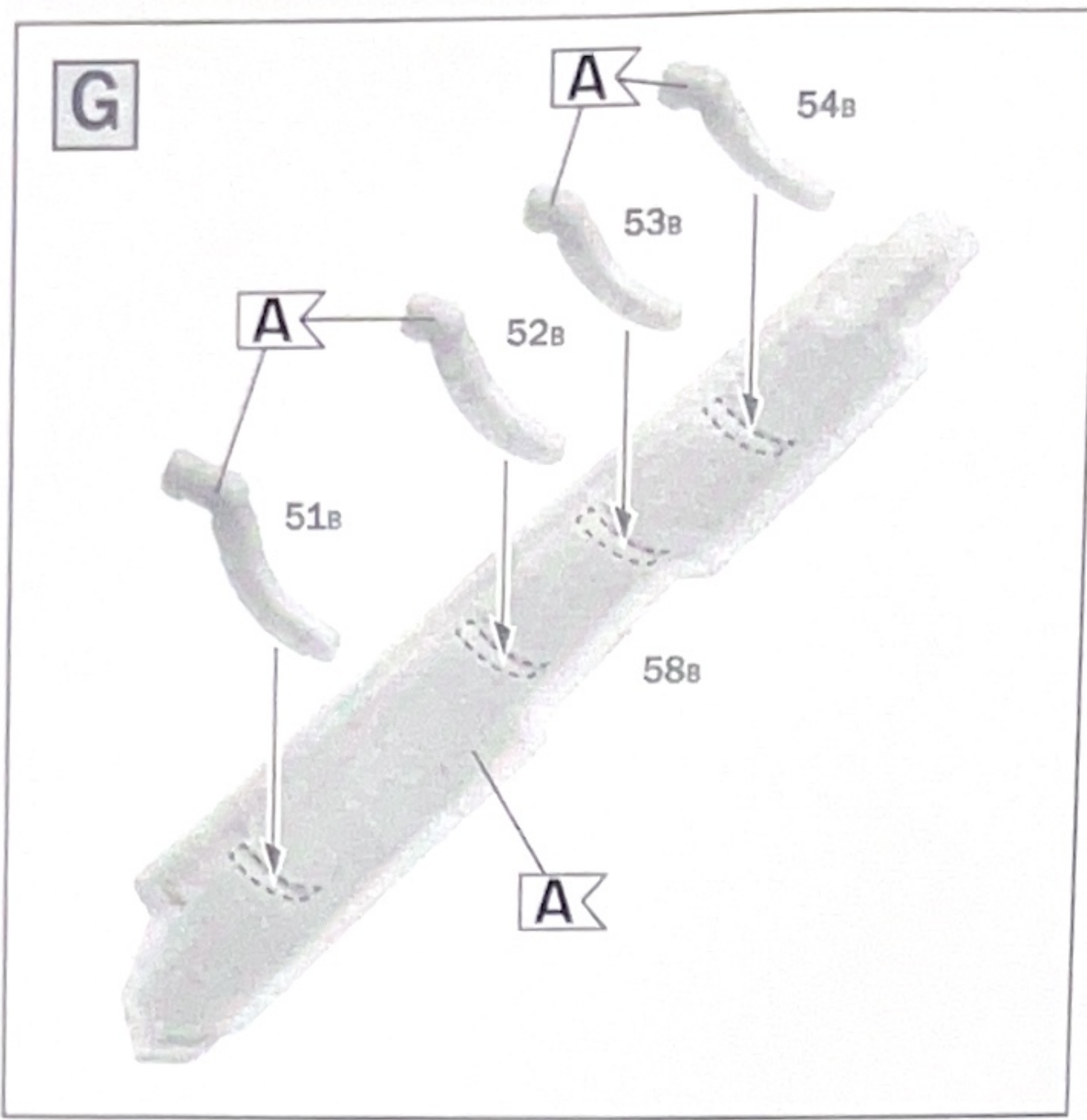

10

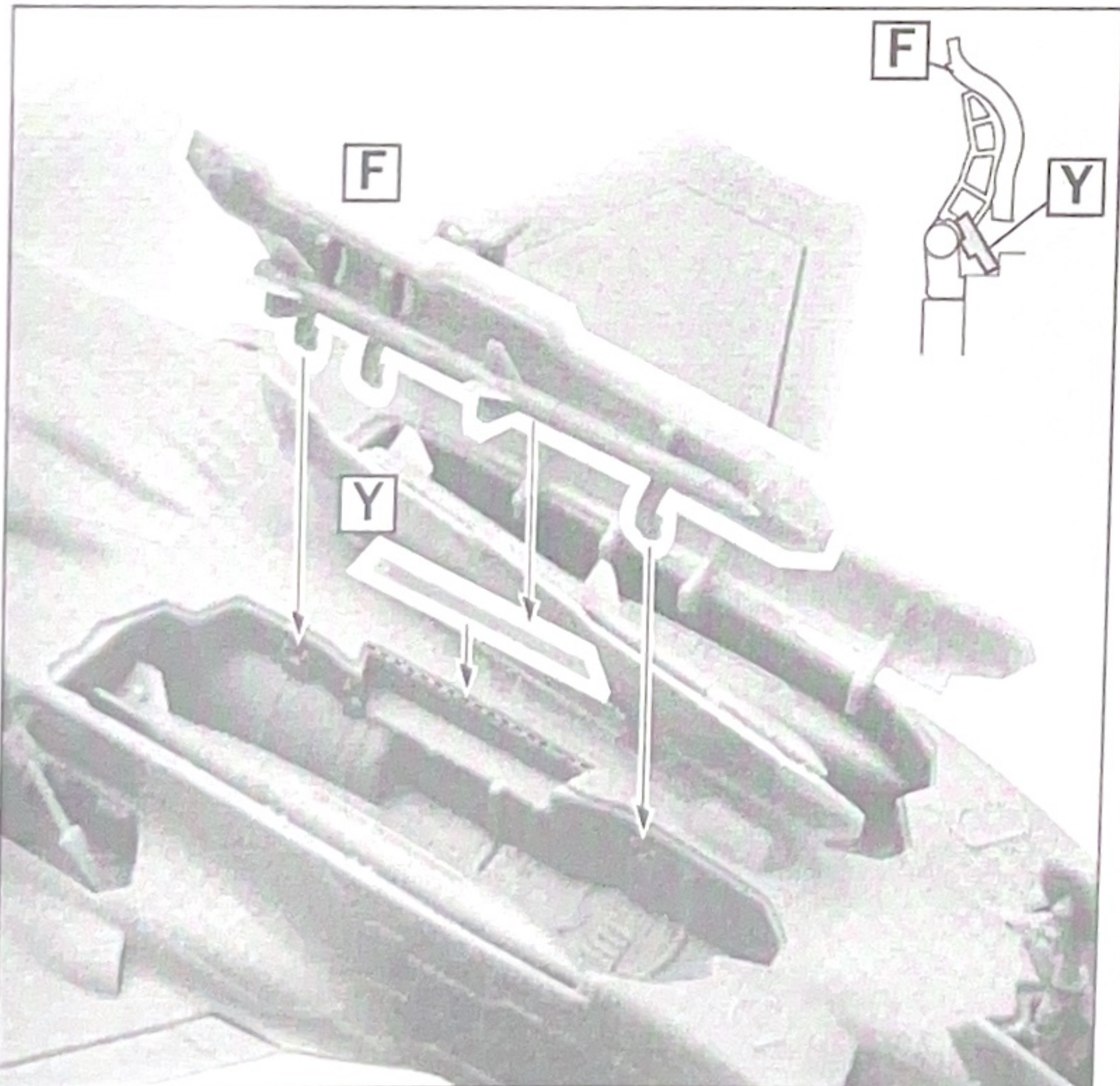
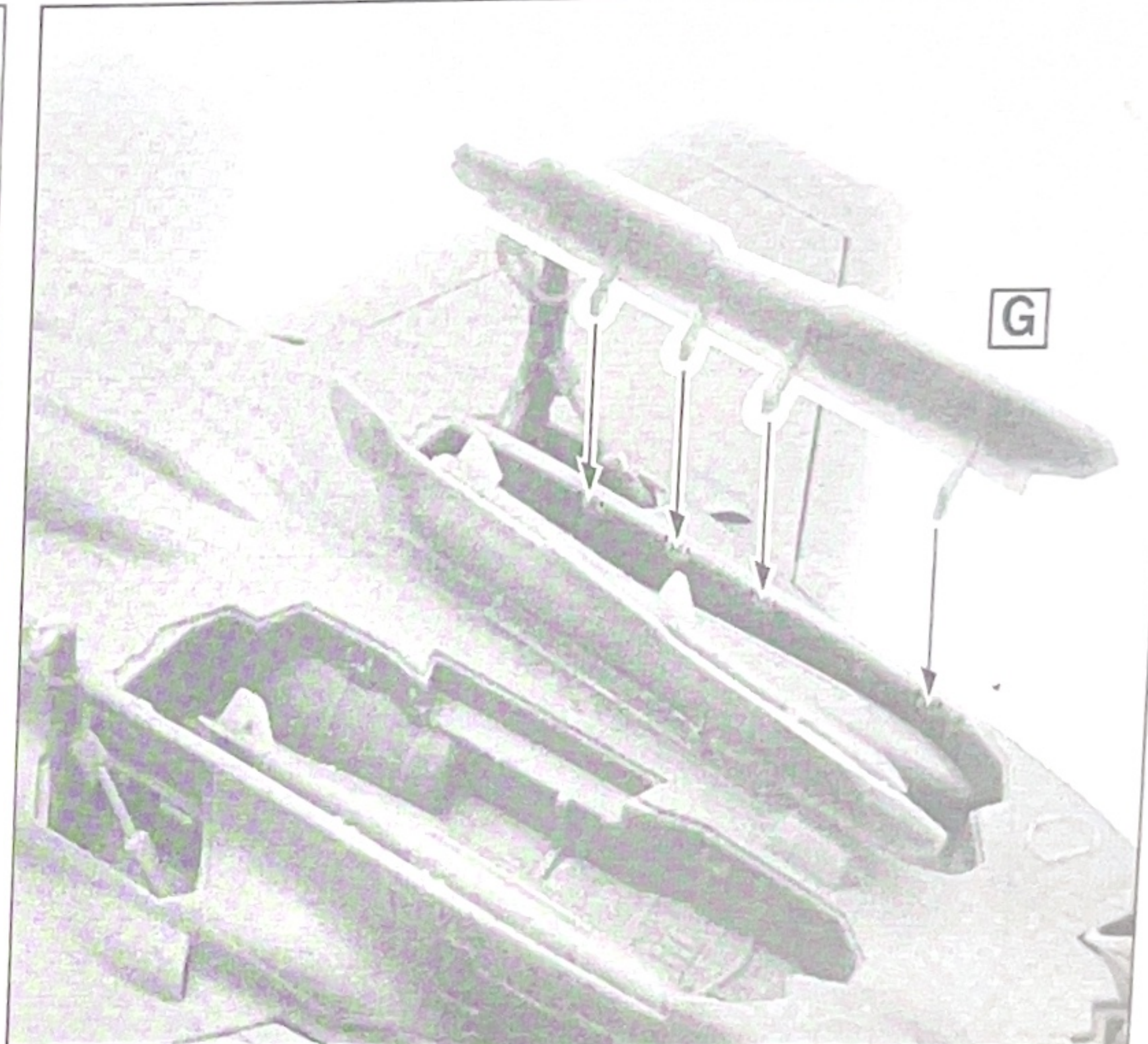
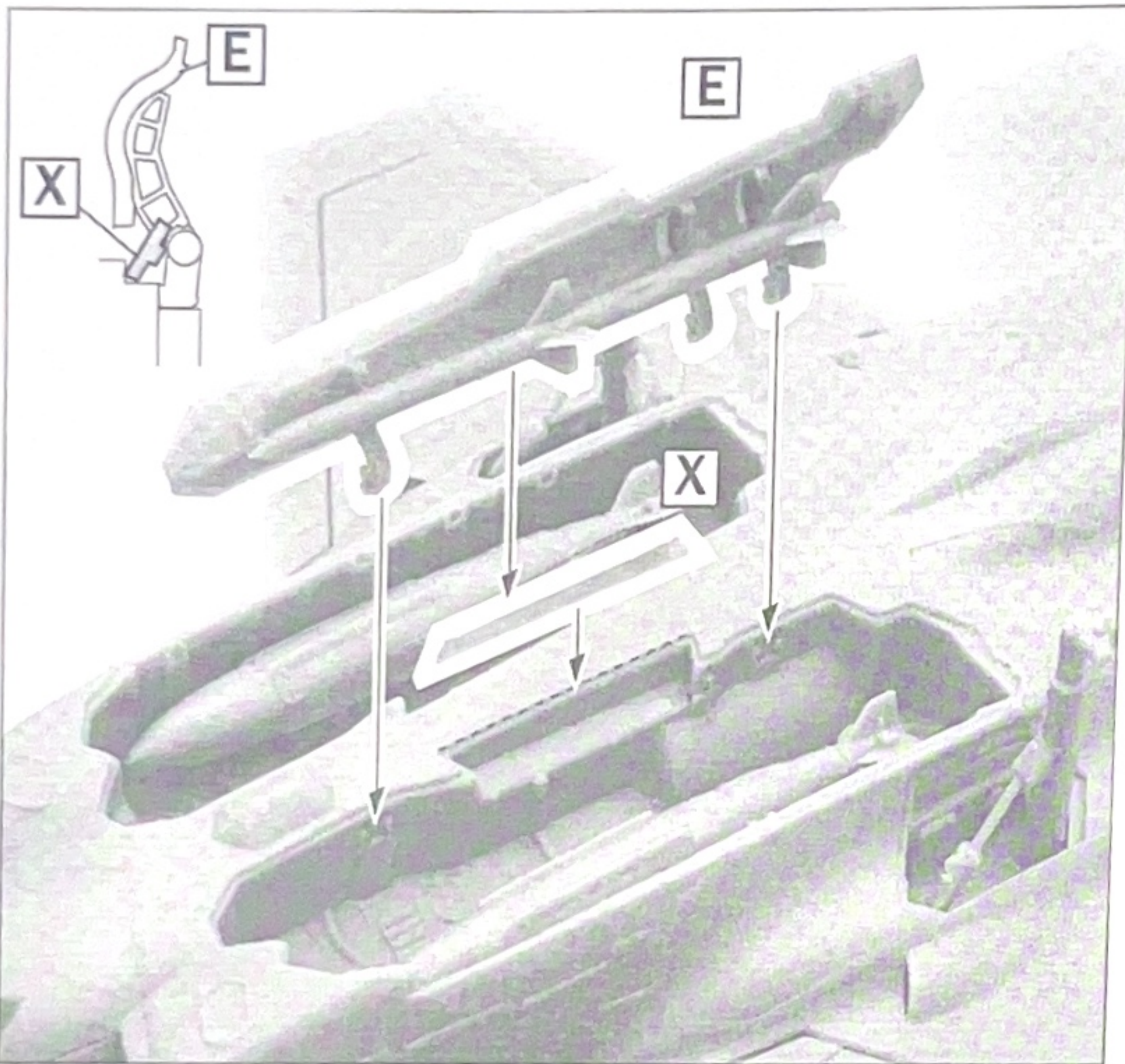

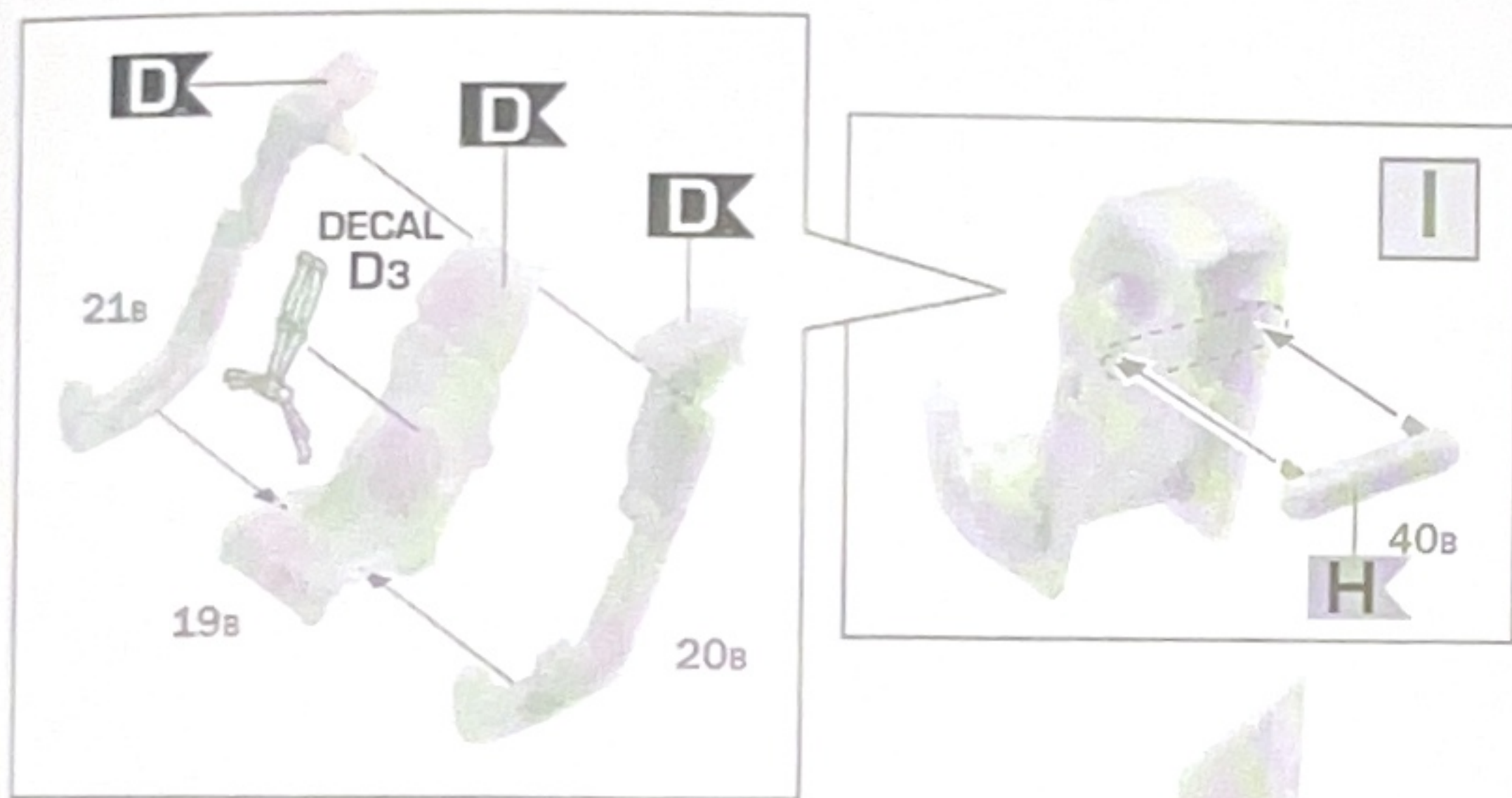
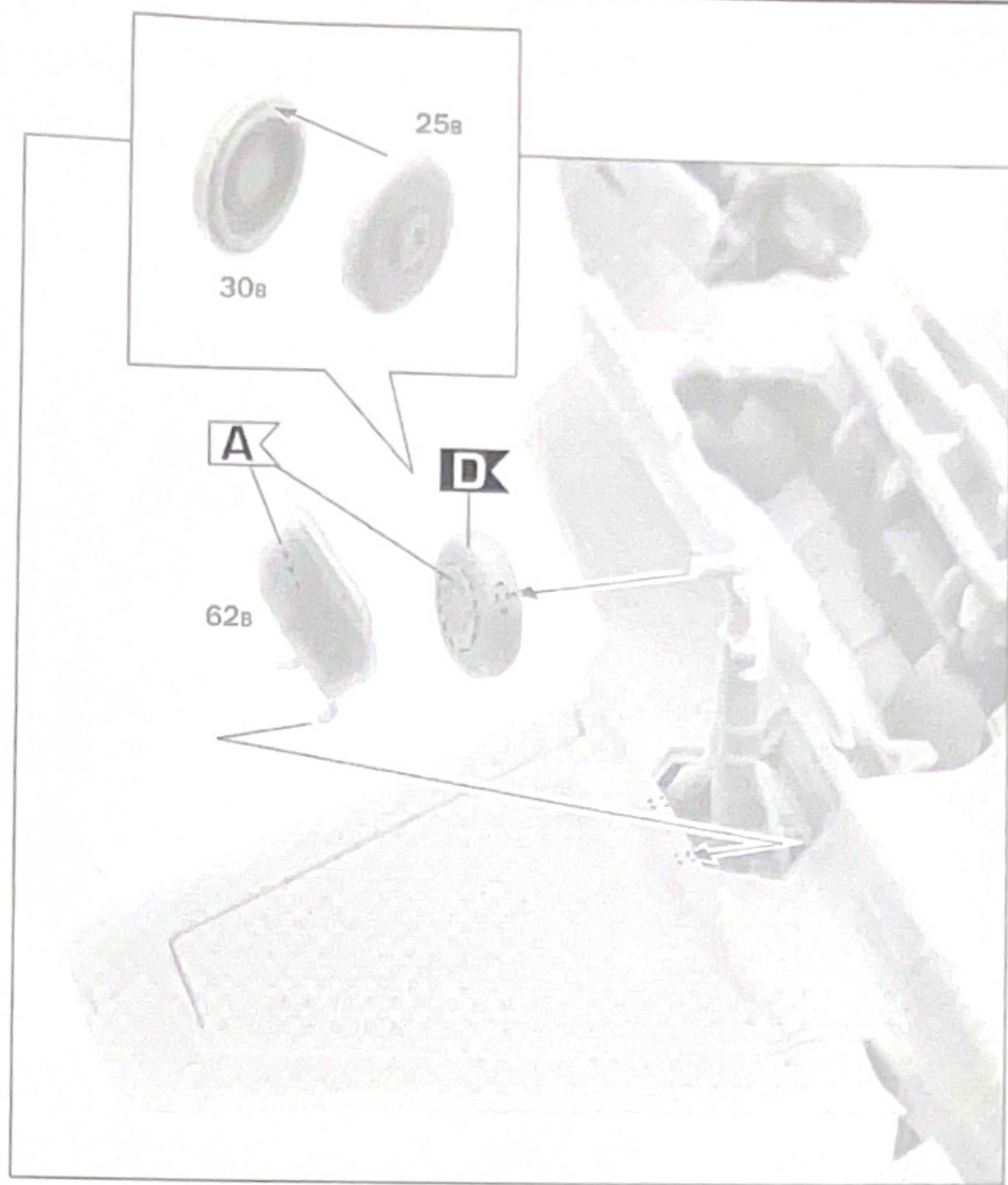
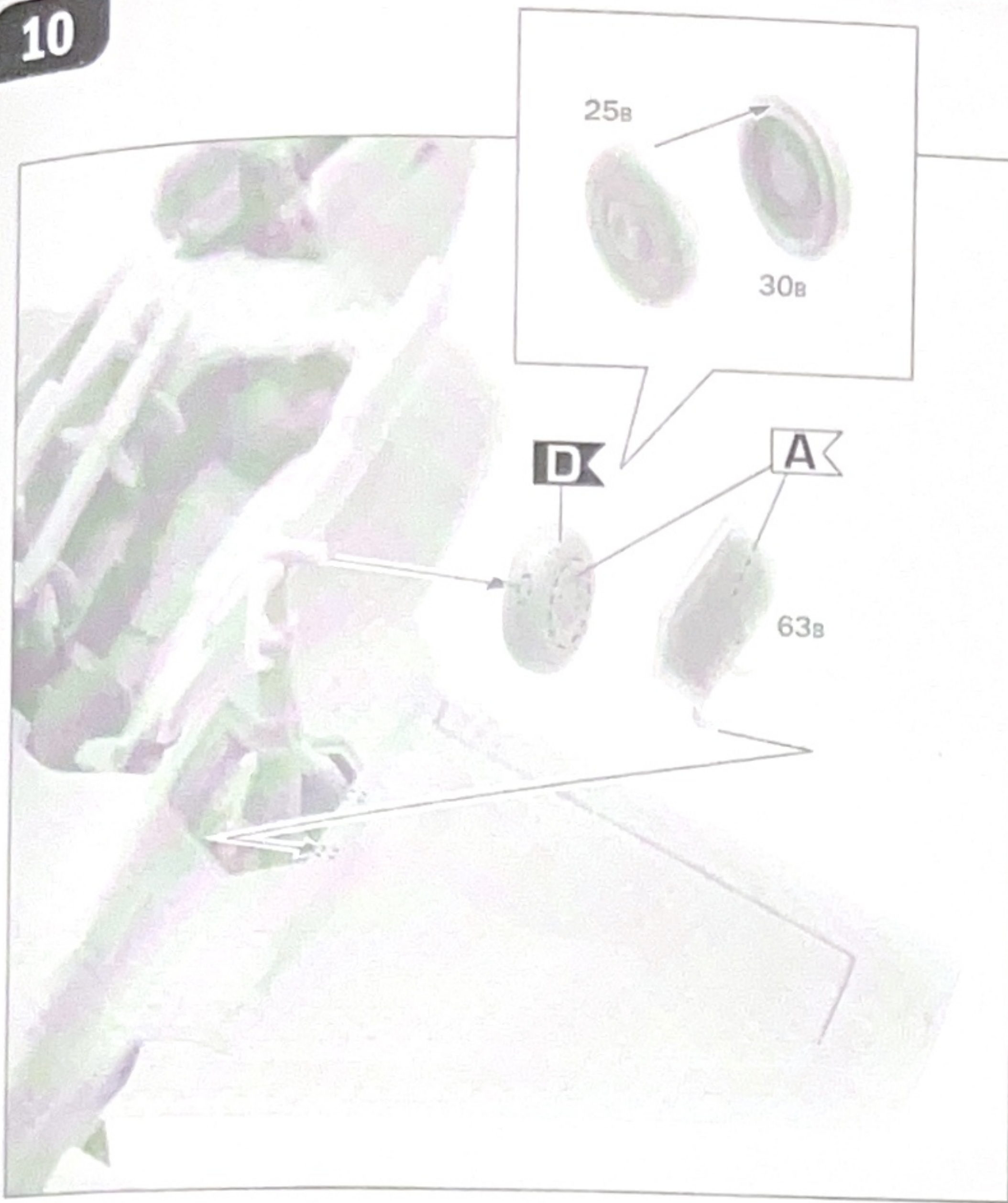

KANOPI AÇIK

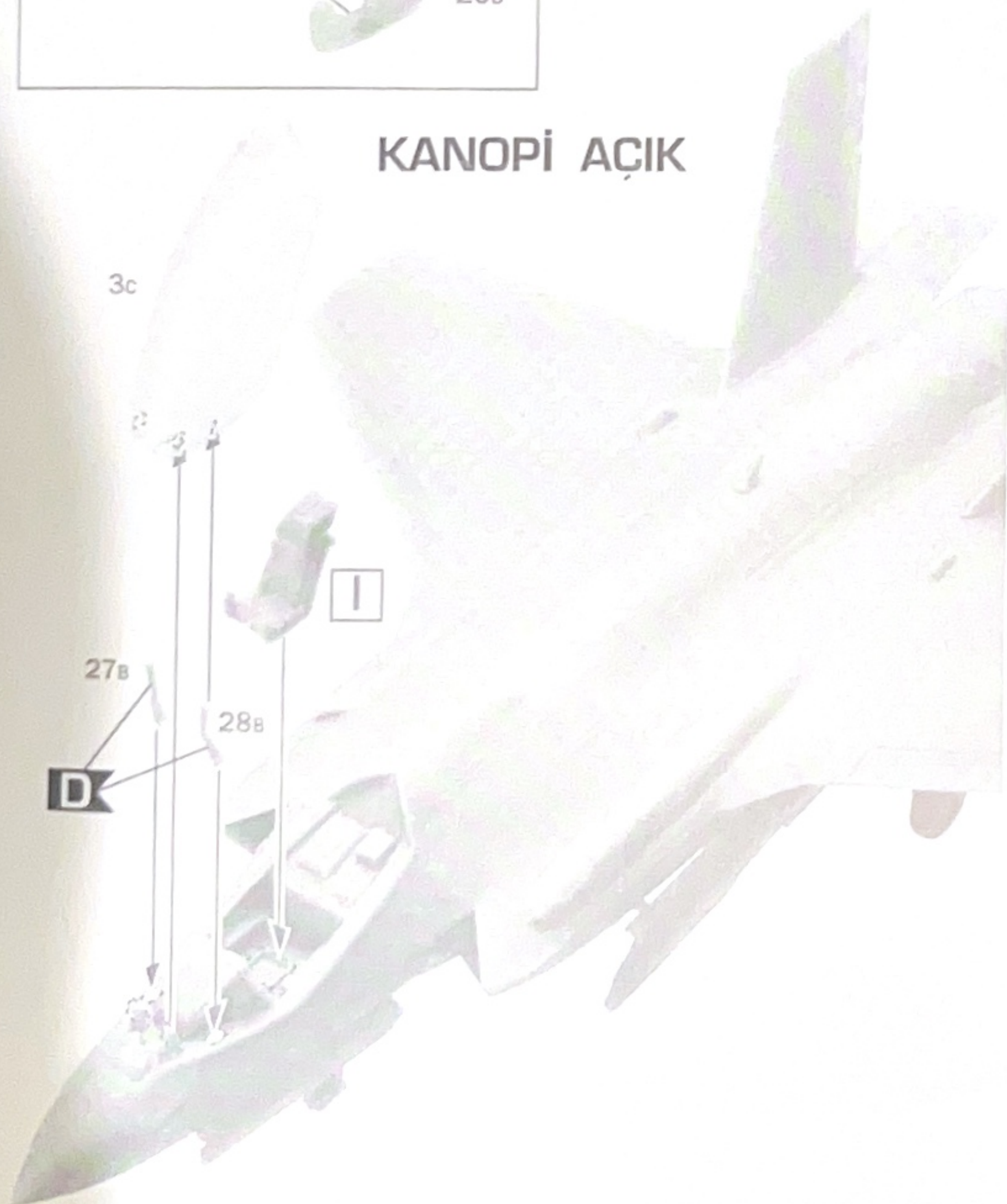

KANOPI KAPALI

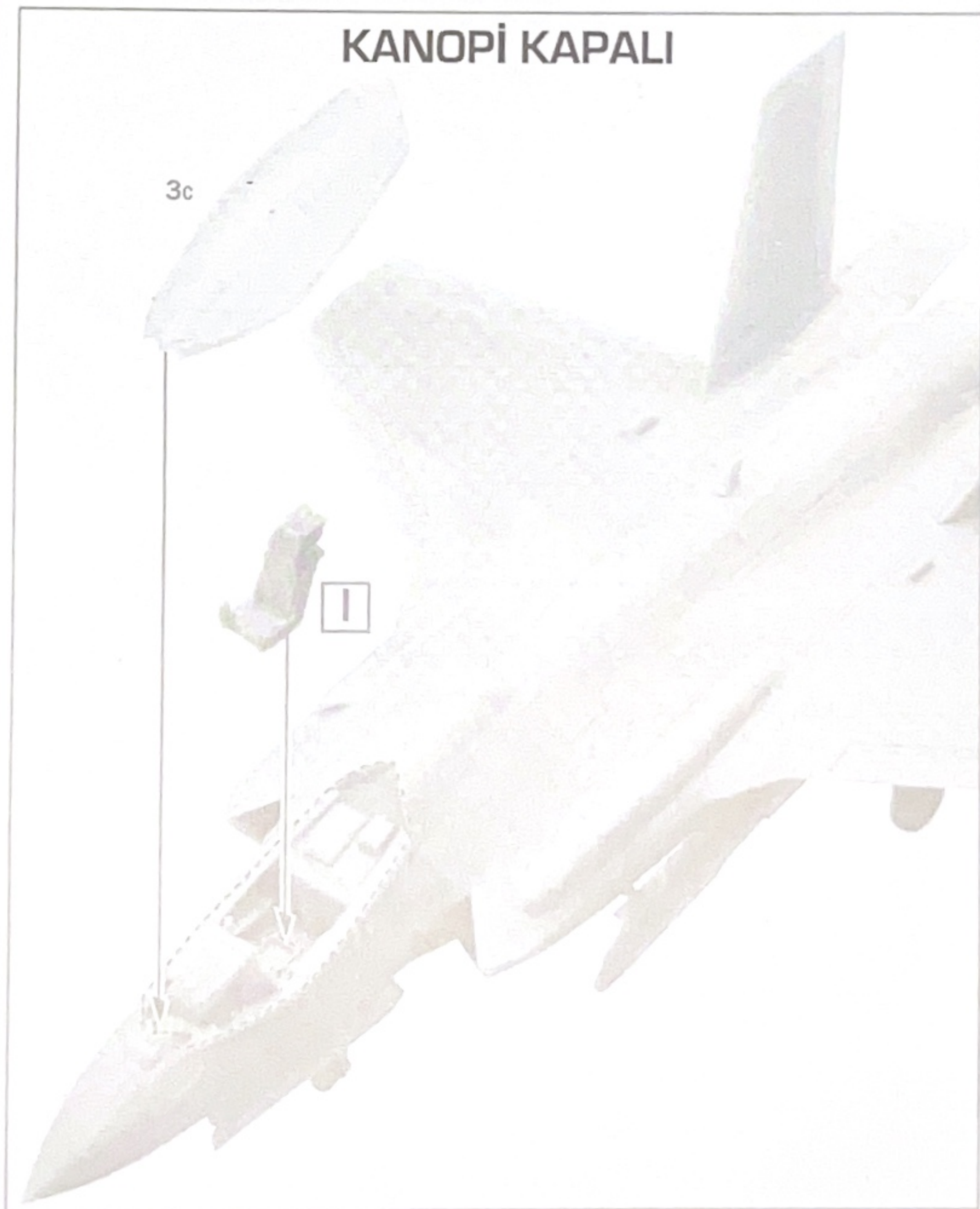

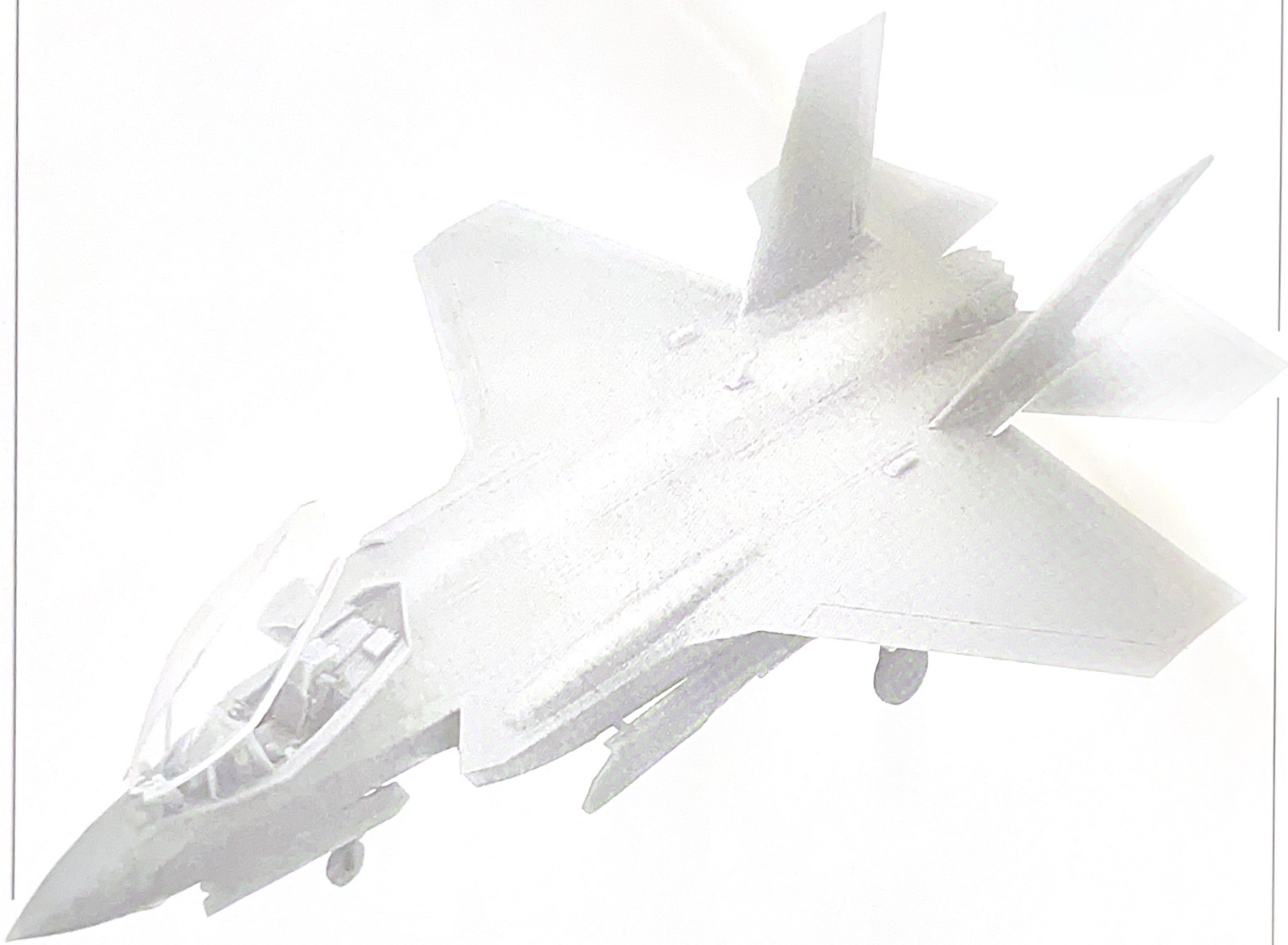

F-35A LIGHTNING II

TÜRK HAVA KUVVETLERİ / TURKISH AIR FORCE

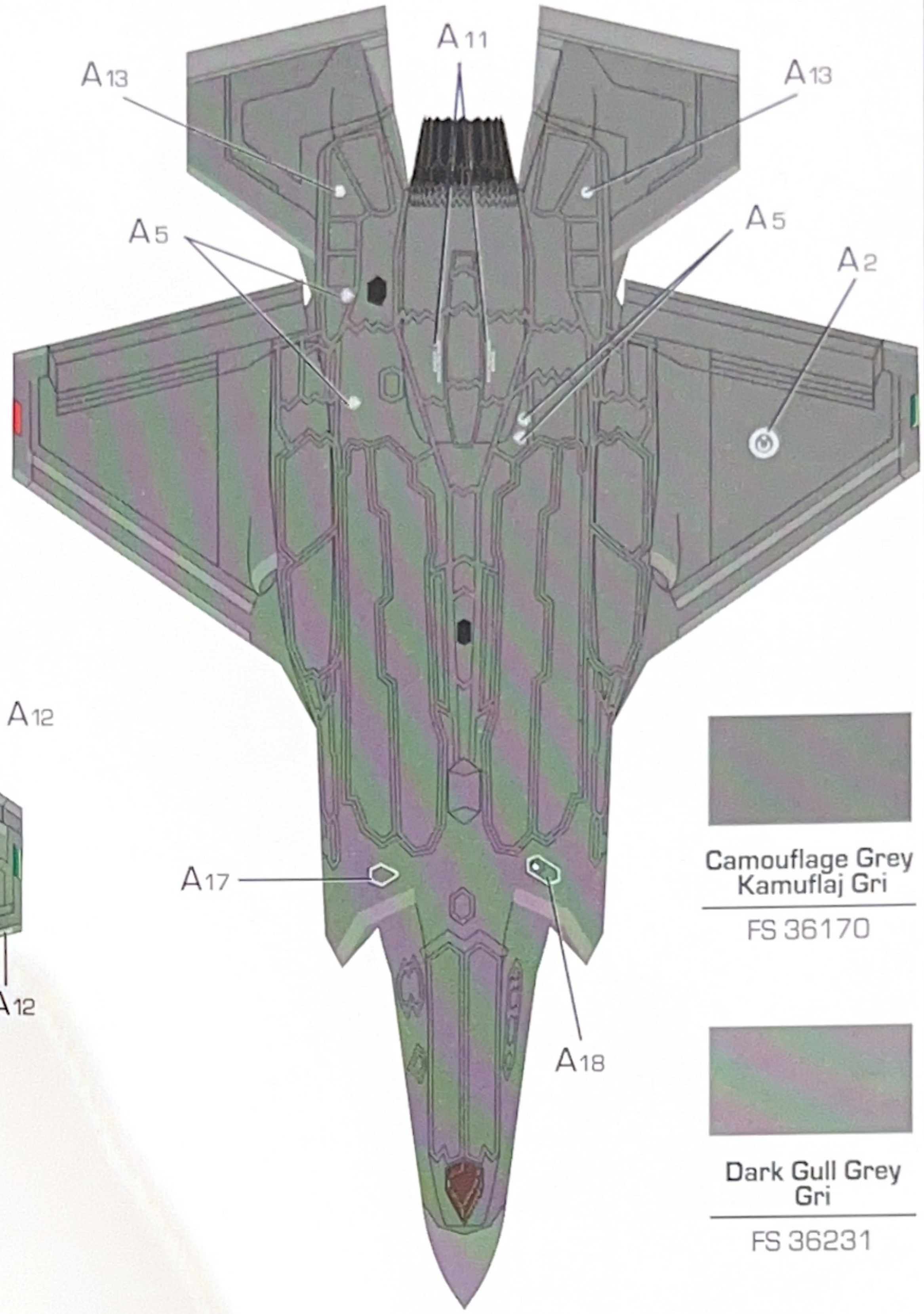
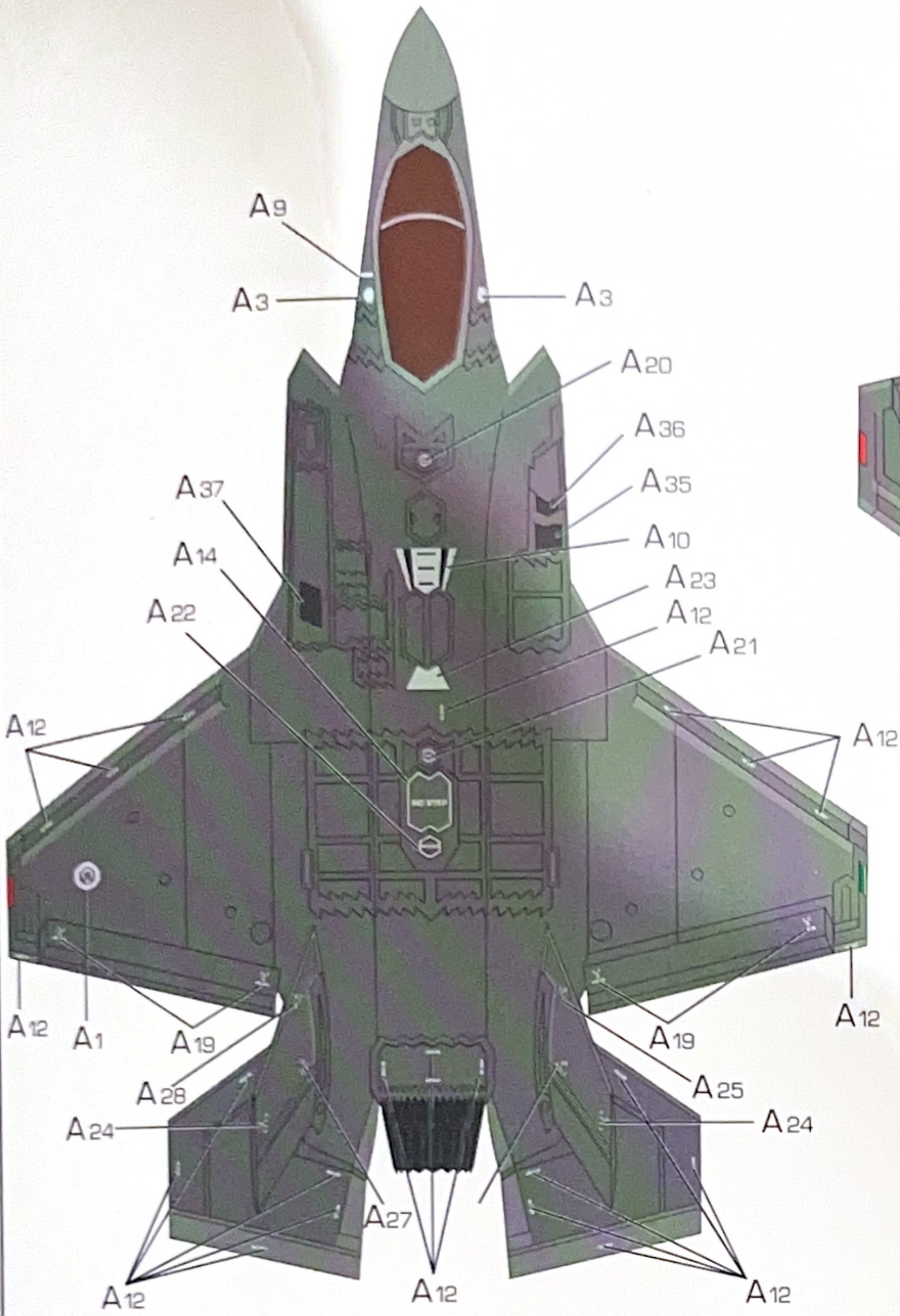

Camouflage Grey
Kamufraj Gri
FS 36170

Dark Gull Grey
Gri
FS 36231

OPSIYONEL

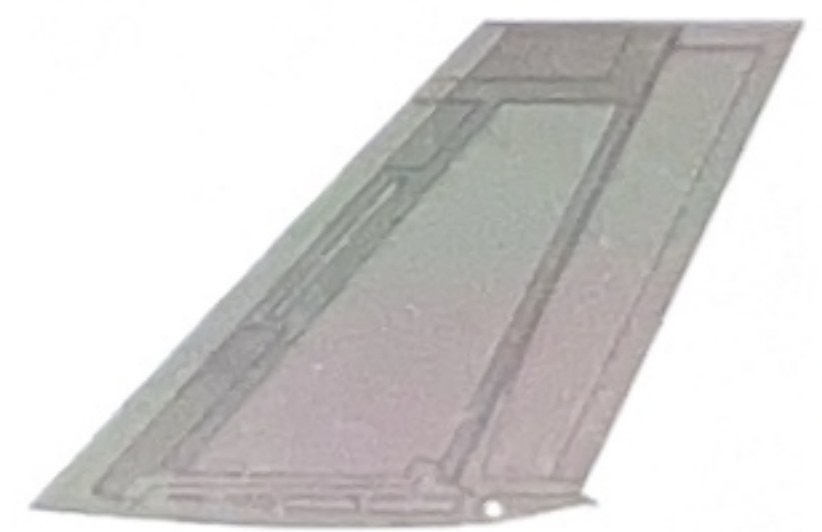
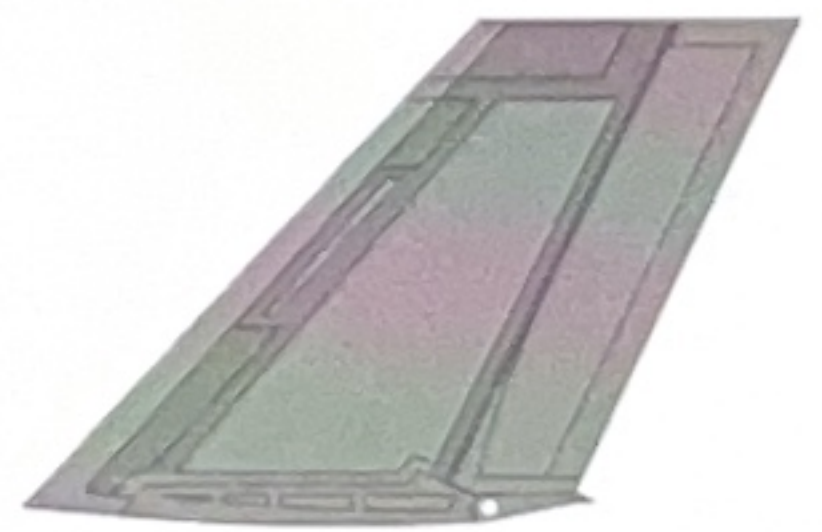
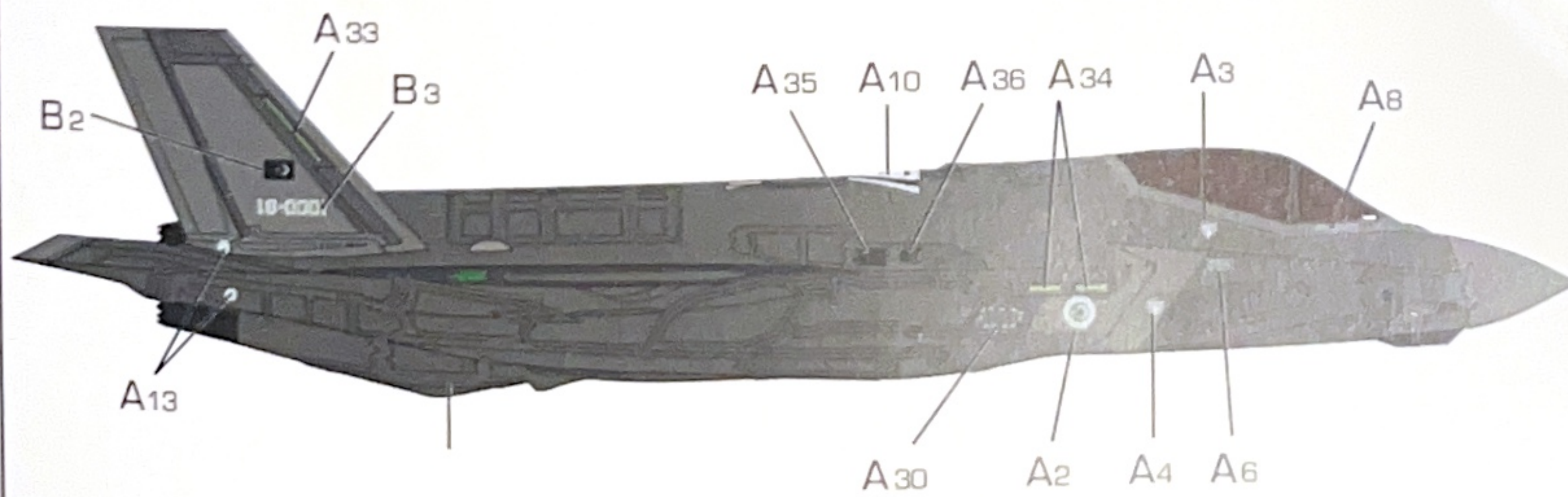
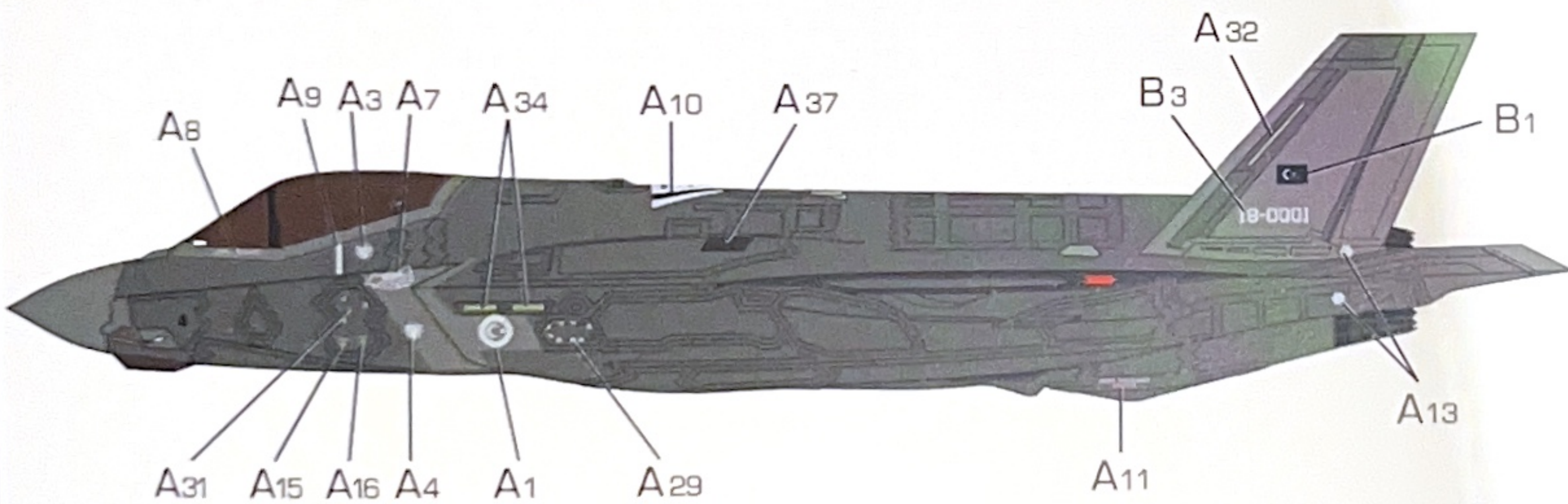

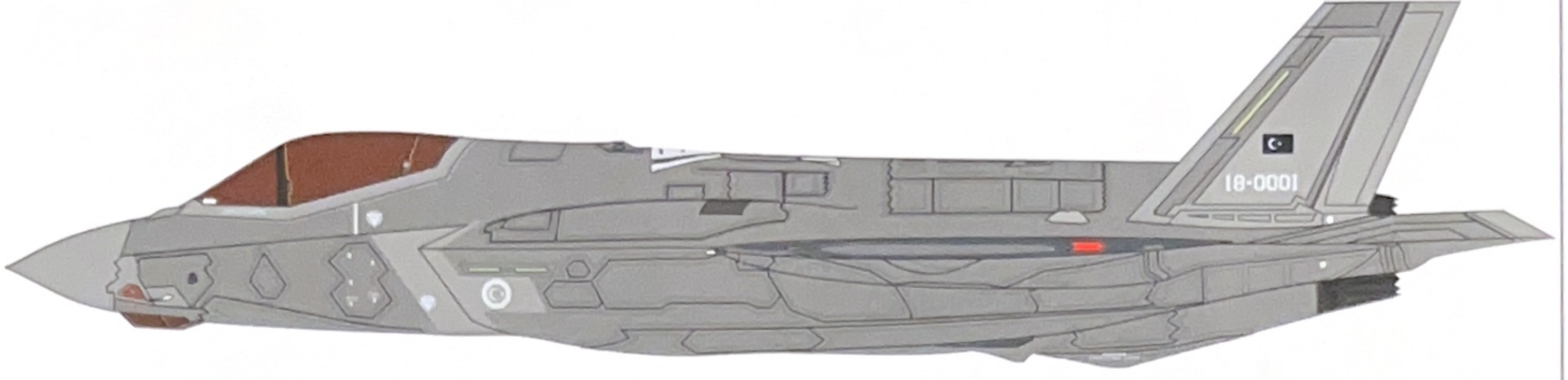

18-0001 "İLK TESLİM ALINAN UÇAKLAR" TEXAS - FORT WORTH / ABD

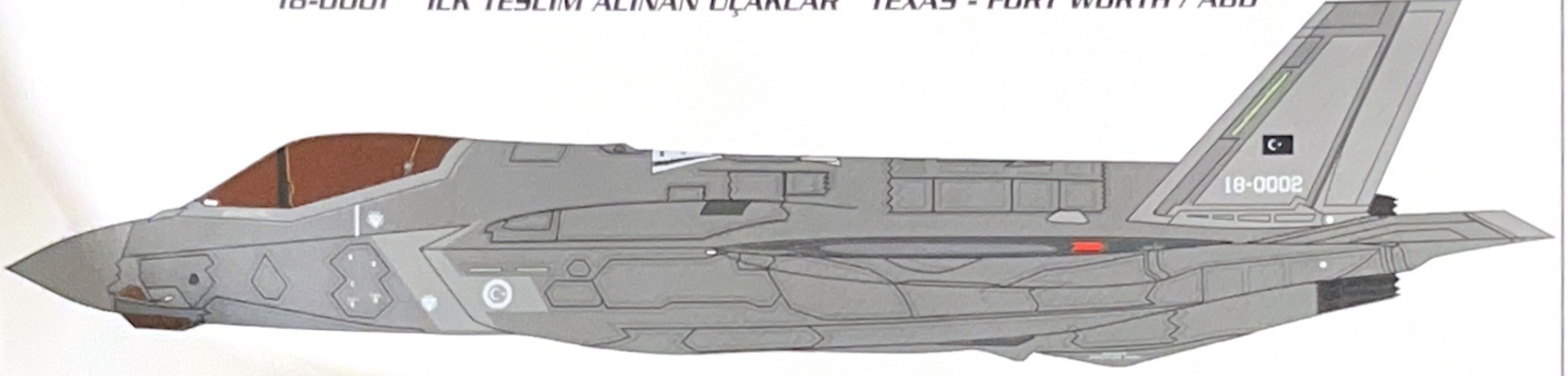

18-0002 "İLK TESLİM ALINAN UÇAKLAR" TEXAS - FORT WORTH / ABD



18-0021 151'inci Filo "TUNÇLAR", Merzifon



19-0016 182'nci Filo "ATMACALAR", Diyarbakır



18-0002 172'nci Filo "ŞAHİNLER", Malatya